

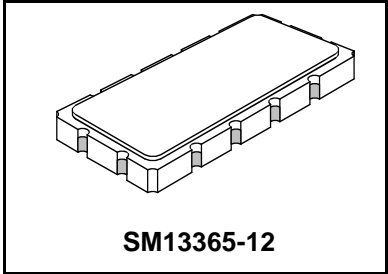

SF1177A

57.6 MHz SAW Filter



- **Designed for Wide Channel IF Filtering**
- **Low Insertion Loss**
- **Hermetic 13.3 x 6.5 mm Surface-mount Case**
- **Balanced or Single Ended Input and Output**
- **Complies with Directive 2002/95/EC (RoHS)**



Absolute Maximum Ratings

Rating	Value	Units
Maximum Incident Power in Passband	+13	dBm
Max. DC voltage between any 2 terminals	30	VDC
Storage Temperature Range	-40 to +85	°C
Suitable for lead-free soldering - Max. Soldering Profile	260°C for 30 s	

Electrical Characteristics

Characteristic	Sym	Notes	Min	Typ	Max	Units
Nominal Frequency	f_N	1		57.6		MHz
Passband bandwidth	1dB B_W		21.2			MHz
Insertion Loss	1_L	1, 2, 3			15.0	dB
Rel. Attenuation to a_{max}	a_{rel}	0 ... 29.8 MHz	45			dB
		85.4 ... 250 MHz	45			
		250 ... 1000 MHz	35			
Amplitude ripple (p-p)	Δa	1, 2, 3			1.5	dB
Group delay ripple (p-p)	$\Delta \tau$				50	ns
1 dB compression			12			dBm
Input IP3			30			dBm
Max. Input level (non-destructive)			13			dBm
Operating Temperature		1	-25		+85	°C
Terminating source impedance				50		Ohm
Terminating load impedance				50		Ohm

Impedance Matching to 50 Ω Unbalanced	External L-C
Case Style	SM13365-12 13.3 x 6.5 mm Nominal Footprint
Lid Symbolization (YY = year, WW = week)	RFM SF1177A YYWW

Electrical Connections

Connection	Terminals
Port 1 Hot	2
Port 2 Hot	8
Case Ground	All others

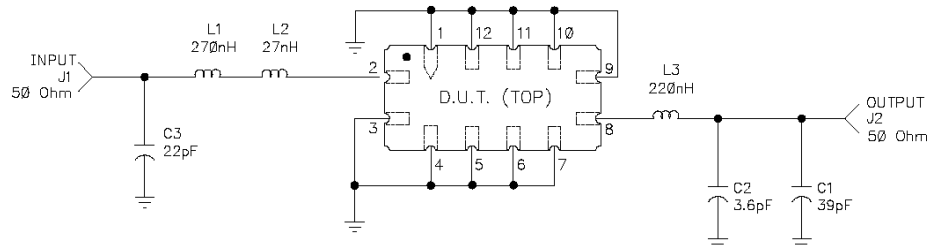

Notes:

1. Unless noted otherwise, all specifications apply over the operating temperature range with filter soldered to the specified demonstration board with impedance matching to 50 Ω and measured with 50 Ω network analyzer.
2. Unless noted otherwise, all frequency specifications are referenced to the nominal center frequency, f_c .
3. Rejection is measured as attenuation below the minimum IL point in the passband. Rejection in final user application is dependent on PCB layout and external impedance matching design. See Application Note No. 42 for details.
4. Part to part absolute delay measurement records the absolute delay mean across 1 dB passband.
5. "LRIP" or "L" after the part number indicates "low rate initial production" and "ENG" or "E" indicates "engineering prototypes."
6. The design, manufacturing process, and specifications of this filter are subject to change.
7. Either Port 1 or Port 2 may be used for either input or output in the design. However, impedances and impedance matching may vary between Port 1 and Port 2, so that the filter must always be installed in one direction per the circuit design.
8. US and international patents may apply.
9. Electrostatic Sensitive Device. Observe precautions for handling.



SM13365-12 Case

12-Terminal Ceramic Surface-Mount Case
13.3 x 6.5 mm Nominal Footprint

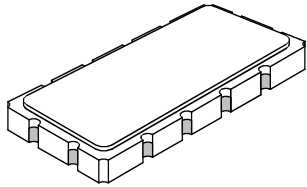

Case Dimensions						
Dimension	mm			Inches		
	Min	Nom	Max	Min	Nom	Max
A	13.08	13.31	13.60	0.515	0.524	0.535
B	6.27	6.50	6.80	0.247	0.256	0.268
C		1.91	2.00		0.075	0.079
D		1.50			0.059	
E		0.79			0.031	
H		1.0			0.039	
P		2.54			0.100	

Materials	
Solder Pad Termination	Au plating 30 - 60 ulnches (76.2-152 uM) over 80-200 ulnches (203-508 uM) Ni.
Lid	Fe-Ni-Co Alloy Electroless Nickel Plate (8-11% Phosphorus) 100-200 ulnches Thick
Body	Al ₂ O ₃ Ceramic
Pb Free	

Electrical Connections		
Connection		Terminals
Port 1	Input or Return	2
	Return or Input	3
Port 2	Output or Return	8
	Return or Output	9
Ground		All others
Single Ended Operation		Return is ground
Differential Operation		Return is hot

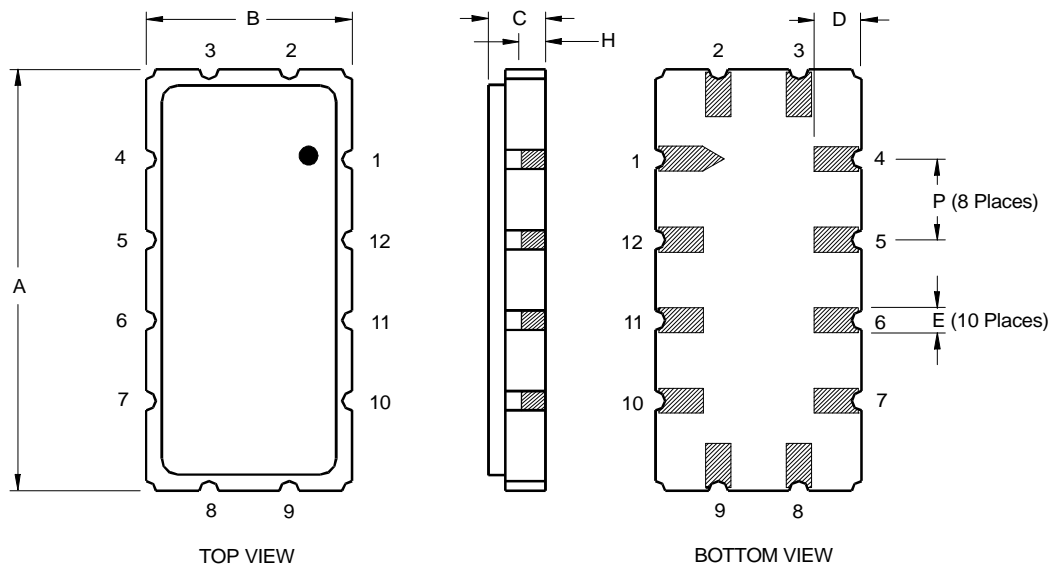

57.6 MHz

SAW Filter

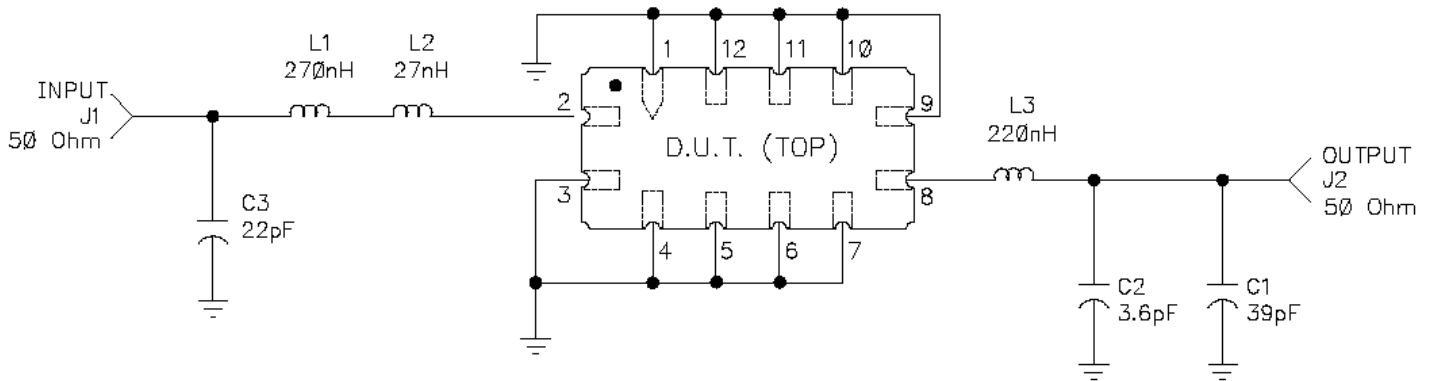
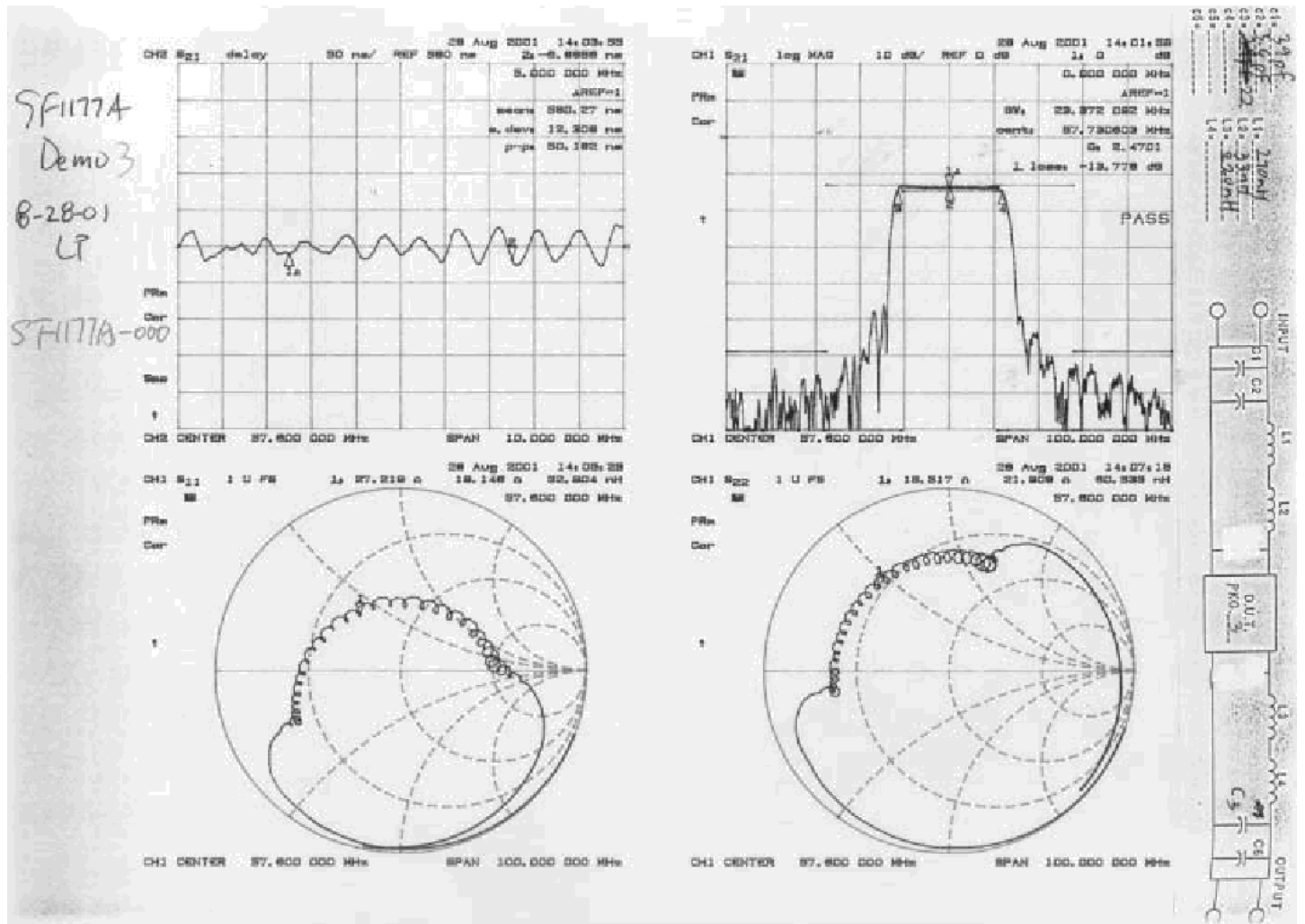

NOTES:

1. SOLDER MOUNT COMPONENTS & CONNECTORS TO PCB1.

2. ORIENT THE FLTR1 AND SOLDER IT DOWN TO THE BOARD AS SHOWN.

