



# SCM9B-3000/4000 Series

## Computer-to-Analog Output Modules

### FEATURES

- ANALOG OUTPUT RANGES: 0-1V,  $\pm 1V$ , 0-5V,  $\pm 5V$ , 0-10V,  $\pm 10V$ , 0-20mA, 4-20mA.
- COMMUNICATES IN ASCII WITH RS-232 OR RS-485 SERIAL PORTS.
- PROGRAMMABLE HIGH/LOW OUTPUT LIMITS.
- 500Vrms OUTPUT ISOLATION.
- 12-BIT OUTPUT RESOLUTION.
- SCALING IN ENGINEERING UNITS.
- BAUD RATES: 300 TO 38,400.
- NONVOLATILE DIGITAL CALIBRATION.
- OUTPUT PROTECTION: 240VAC (CURRENT OUTPUT),  $\pm 30V$  (VOLTAGE OUTPUTS).
- DIRECT CONNECTION TO 'DUMB' TERMINALS OR MODEMS.
- REQUIRES +10 to +30Vdc UNREGULATED SUPPLY.
- MAY BE LOCATED UP TO 10,000 FEET FROM HOST (RS-485).
- ADDRESSABLE: UP TO 124 UNITS PER SERIAL PORT.
- 'BUMPLESS' MANUAL CONTROL INPUTS.

### DESCRIPTION

The SCM9B-3000/4000 series are complete computer-to-analog output interfaces. They are designed to be mounted remotely from a host computer and communicate, in ASCII, with standard RS-232 and RS-485 serial ports. Simple ASCII commands are used to control a 12-bit DAC (Digital-to-Analog Converter) which is scaled to provide commonly used current and voltage ranges. An 8-bit CMOS microprocessor provides an intelligent interface between the host and the DAC. The 3000/4000 are compatible with the 1000/2000 input modules and may be mixed in any order.

The modules are easy to use. You do not need engineering experience in complicated data acquisition hardware. This modular approach to data acquisition is extremely flexible, easy to use and cost effective. The modules can be mixed and matched to fit the application. They can be placed remote from the host and from each other. You can string up to 124 modules on one set of wires.

Although software is not required, utility software (SCM9B-S1000) is available on IBM-compatible diskette to make the 3000/4000 easier to learn and use. S1000 software is provided at no charge on request with a purchase order and is not copy protected.

### PROGRAMMABLE FEATURES (4000 Series)

*(Provides intelligent features not found in the 3000 Series.)*

- Fully Programmable Output Slopes: 0.01V/s (mA/s) to 10,000V/s (mA/s).
- Programmable Data Scaling to any Desired Units.
- True Analog Readback of Output Signal.
- Programmable Starting Value.
- Programmable Watchdog Timer Provides Orderly Shutdown in the Event of Host Failure.

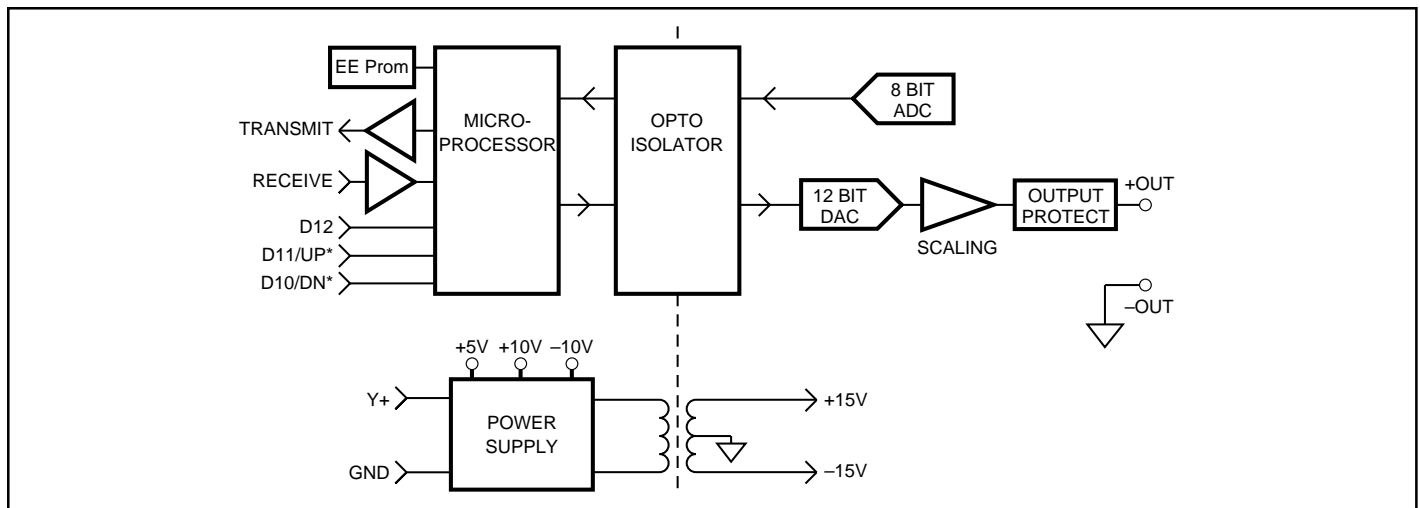

Figure 1. Block Diagram: SCM9B-3000/4000

Call 800-444-7644  
For Information and Assistance



## SPECIFICATIONS — SCM9B-3000/4000

(Typical at +25°C and nominal power supply unless otherwise noted).

<p><b>Analog Output</b></p> <ul style="list-style-type: none"> <li>• Single channel analog output. Voltage: 0-1V, <math>\pm 1V</math>, 0-5V, <math>\pm 5V</math>, 0-10V, <math>\pm 10V</math>. Maximum output current: 5mA Current: 0-20mA, 4-20mA. Compliance Voltage: 12V</li> <li>• Output isolation: 500V rms.</li> <li>• 12-bit output resolution.</li> <li>• Accuracy (Integral &amp; Differential Nonlinearity): 0.1% FSR (max).</li> <li>• Zero drift: <math>\pm 30\mu V/^\circ C</math> (Voltage Output max). <math>\pm 0.2\mu A/^\circ C</math> (Current Output max).</li> <li>• Span tempco: <math>\pm 25\text{ppm}/^\circ C</math> max.</li> <li>• 1000 conversions per second.</li> <li>• Settling time to 0.1% FS: 300<math>\mu s</math> typ (1ms max).</li> <li>• Output change manual mode (-FS to +FS): 5s.</li> <li>• Programmable output slope (4000): 0.01V/s (mA/s) to 10,000V/s (mA/s).</li> <li>• Current output voltage compliance: 12V.</li> <li>• Voltage Output drive: 5mA min, 10mA max.</li> </ul>	<p><b>Communications</b></p> <ul style="list-style-type: none"> <li>• Communications in ASCII via RS-232C, RS-485 ports.</li> <li>• Selectable baud rates: 300, 600, 1200, 2400, 4800, 9600, 19200, 38400.</li> <li>• NRZ asynchronous data format: 1 start bit, 7 data bits, 1 parity bit and 1 stop bit.</li> <li>• Parity: odd, even, none.</li> <li>• User selectable channel address.</li> <li>• ASCII format command/response protocol.</li> <li>• Up to 124 multidrop modules/host communications port.</li> <li>• Communications distance up to 10,000 feet (RS-485).</li> <li>• Can be used with "dumb" terminal.</li> <li>• All communications setups (address, baud rate, parity) stored in nonvolatile memory using EEPROM.</li> <li>• Checksum can be added to any command or response.</li> </ul>
<p><b>Analog Output Readback (4000)</b></p> <ul style="list-style-type: none"> <li>• 8-bit analog to digital converter.</li> <li>• Accuracy over temperature (-25 to +70°C): 2.0% FS max.</li> </ul>	<p><b>Power</b></p> <ul style="list-style-type: none"> <li>• Requirements: Unregulated +10V to +30Vdc, 0.75W max. (Voltage Output), 1.0W max. (Current Output).</li> <li>• Internal switching regulator.</li> <li>• Protected against power supply reversals.</li> </ul>
<p><b>Digital</b></p> <ul style="list-style-type: none"> <li>• 8-bit CMOS microcomputer.</li> <li>• Digital scaling and calibration stored in nonvolatile memory.</li> <li>• Programmable High/Low output limits.</li> <li>• Programmable data scaling (4000).</li> <li>• Programmable starting value (4000).</li> <li>• Programmable watchdog timer provides orderly shutdown in the event of host failure (4000).</li> </ul>	<p><b>Mechanical</b></p> <ul style="list-style-type: none"> <li>• Dimensions: See dimension drawing.</li> <li>• Case: ABS with captive mounting hardware.</li> <li>• Connectors: Screw terminal barrier plug (supplied). Replace with Phoenix MSTB 1.5/10 ST 5.08 or equivalent.</li> </ul>
<p><b>Digital Inputs</b></p> <ul style="list-style-type: none"> <li>• Three digital inputs per module.</li> <li>• Voltage levels: <math>\pm 30V</math> without damage.</li> <li>• Switching levels: High, 3.5V min., Low, 1.0V max.</li> <li>• Internal pull up resistors for direct switch input.</li> </ul>	<p><b>Environmental</b></p> <ul style="list-style-type: none"> <li>• Temperature Range: Operating -25°C to +70°C. Storage -25°C to +85°C.</li> <li>• Relative Humidity: 0 to 95% noncondensing.</li> </ul>

Specifications are subject to change without notice.