

Hermetic Package TBD

Description:

Powerex IGBT Hermetic modules are designed for use in switching applications. Each Module consists of two IGBT transistors, four super fast free wheel diodes in an asymmetrical half bridge configuration with each transistor having a reverse connected super fast recovery free wheel diode. All components are located in a hermetically sealed chamber and are electrically isolated from the heat sinking base plate, offering simplified system assembly and thermal management.

Features:

- ◆ Low Drive Power
- ◆ Low $V_{CE(sat)}$
- ◆ Discrete Super-Fast Recovery (70ns) Free-Wheel Diode
- ◆ Isolated Base plate for Easy Heat sinking
- ◆ Fully Hermetic Package
- ◆ Package Design Capable of Use at High Altitudes
- ◆ Package can be modified to adhere to customer dimensions.
- ◆ High Capacity Diodes (D1 & D3)

Schematic:

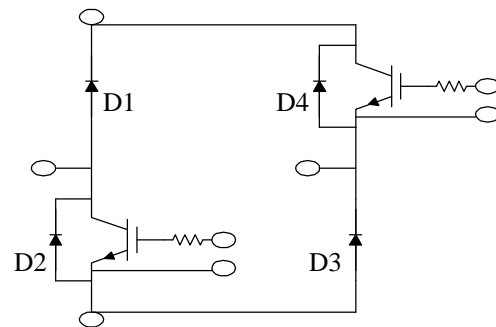

Applications:

- ◆ AC Motor Control
- ◆ Motion/Servo Control
- ◆ Air Craft Applications

Ordering Information:



QIP0640001

Powerex Inc., 200 Hillis St., Youngwood, PA 15697 (724)925-7272

Asymmetrical Half Bridge IGBT H-Series
Hermetic Module
400 Amperes/600 Volts

Contact Powerex Custom Modules

Maximum Ratings, T_j=25°C unless otherwise specified

Ratings	Symbol		Units
Collector Emitter Voltage	V _{CES}	600	Volts
Gate Emitter Voltage	V _{GES}	±20	Volts
Collector Current	I _C	400	Amperes
Peak Collector Current	I _{CM}	800*	Amperes
Diode Forward Current (D2,D4)	I _{FM}	400	Amperes
Diode Forward Surge Current (D2,D4)	I _{FM}	800*	Amperes
Diode Forward Current (D1,D3)	I _{FM}	400	Amperes
V Isolation	V _{RMS}	2500	Volts

Static Electrical Characteristics, T_j=25°C unless otherwise specified

Characteristic	Symbol	Test Conditions	Min	Typ	Max	Units
Collector Cutoff Current	I _{CES}	V _{CE} =V _{CES}			1.0	mA
Gate Leakage Current	I _{GES}	V _{CE} =0V			0.5	μA
Gate-Emitter Threshold Voltage	V _{GE(th)}	I _C =40mA, V _{CE} =10V	4.5	6.0	7.5	Volts
Collector-Emitter Saturation Voltage	V _{CE(sat)}	I _C =400A, V _{GE} =15V		2.1	2.8	Volts
	V _{CE(sat)}	I _C =400A, V _{GE} =15V, T _j =150°C		2.15		Volts
Total Gate Charge	Q _G	V _{CC} =300V, I _C =400A, V _{GS} =15V		1200		nC
Diode Forward Voltage (D1,D3)	V _{FM}	I _E =400A, V _{GS} =0V			2.0	Volts
Diode Forward Voltage (D2,D4)	V _{FM}	I _E =200A, V _{GS} =0V			2.8	Volts

Dynamic Electrical Characteristics, T_j=25°C unless otherwise specified

Characteristic	Symbol	Test Conditions	Min	Typ	Max	Units
Input Capacitance	C _{ies}	V _{GE} =0V			40	nF
Output Capacitance	C _{oes}	V _{CE} =10V			14	nF
Reverse Transfer Capacitance	C _{res}	f=1MHz			8	nF
Turn on Delay time	t _{d(on)}	V _{CC} =300V			350	nS
Rise Time	t _r	I _C =200A			600	nS
Turn off delay time	t _{d(off)}	V _{GE1} =V _{GE2} =15V			350	nS
Fall Time	t _f	R _G =1.6Ω			300	nS
Diode Reverse Recovery (D1,D3)	t _{rr}	I _E =400A			400	nS
Diode reverse Recovery Charge (D1, D3)	Q _{rr}	di _E /dt=- 400A/μS		80		μC
Diode Reverse Recovery (D2, D4)	t _{rr}	I _E =200A			110	nS
Diode reverse Recovery Charge (D2,D4)	Q _{rr}	di _E /dt=- 400A/μS		1.08		μC



QIP0640001

Powerex Inc., 200 Hillis St., Youngwood, PA 15697 (724)925-7272

Asymmetrical Half Bridge IGBT H-Series
Hermetic Module
400 Amperes/600 Volts

Thermal and Mechanical Characteristics, T_j=25°C unless otherwise specified

Characteristic	Symbol	Test Conditions	Min	Typ	Max	Units
Thermal Resistance, Junction to Case	R _{θJC}	Per IGBT			0.085	°C/W
Thermal Resistance, Junction to Case (D1,D3)	R _{θJC}	Per Diode			0.08	°C/W
Thermal Resistance, Junction to Case (D2,D4)	R _{θJC}	Per Diode			0.18	°C/W