



M.S.KENNEDY CORP.

1200V/450A HALF BRIDGE PEM

4810

4707 Dey Road Liverpool, N.Y. 13088

(315) 701-6751

FEATURES:

- Half Bridge Configuration
- 1200V Rated Voltage
- 450A Continuous Output Current
- Internal Zener Clamps on Gates
- Proprietary Encapsulation Provides Near Hermetic Performance
- MIL-PRF-38534 Screening Available (Modified)
- Light Weight Domed ALSIC Baseplate
- Robust Mechanical Design for Hi-Rel Applications
- Ultra-Low Inductance Internal Layout
- Withstands 96 Hours HAST and Thermal Cycling (-55°C to +125°C)
- High Side Collector Sense Pin for De-Sat Detection

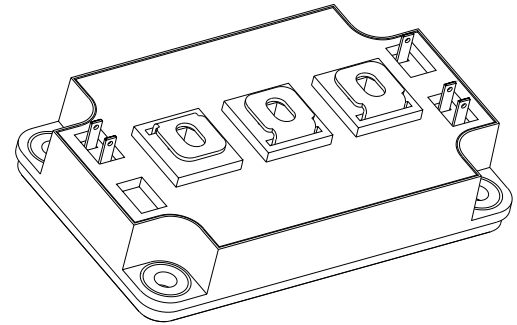

DESCRIPTION:

The MSK 4810 is one of a family of plastic encapsulated modules (PEM) developed specifically for use in military, aerospace and other severe environment applications. The half bridge configuration and 1200 volt/450 amp rating make it ideal for use in high current motor drive and inverter applications. The Aluminum Silicon Carbide (AlSiC) baseplate offers superior flatness and light weight; far better than the copper or copper alloys found in most high power plastic modules. The high thermal conductivity materials used to construct the MSK 4810 allow high power outputs at elevated baseplate temperatures. Our proprietary coating, SEES™ - Severe Environment Encapsulation System - protects the internal circuitry of MSK PEM's from moisture and contamination, allowing them to pass the rugged environmental screening requirements of military and aerospace applications. MSK PEM's are also available with industry standard silicone gel coatings for a lower cost option.

EQUIVALENT SCHEMATIC

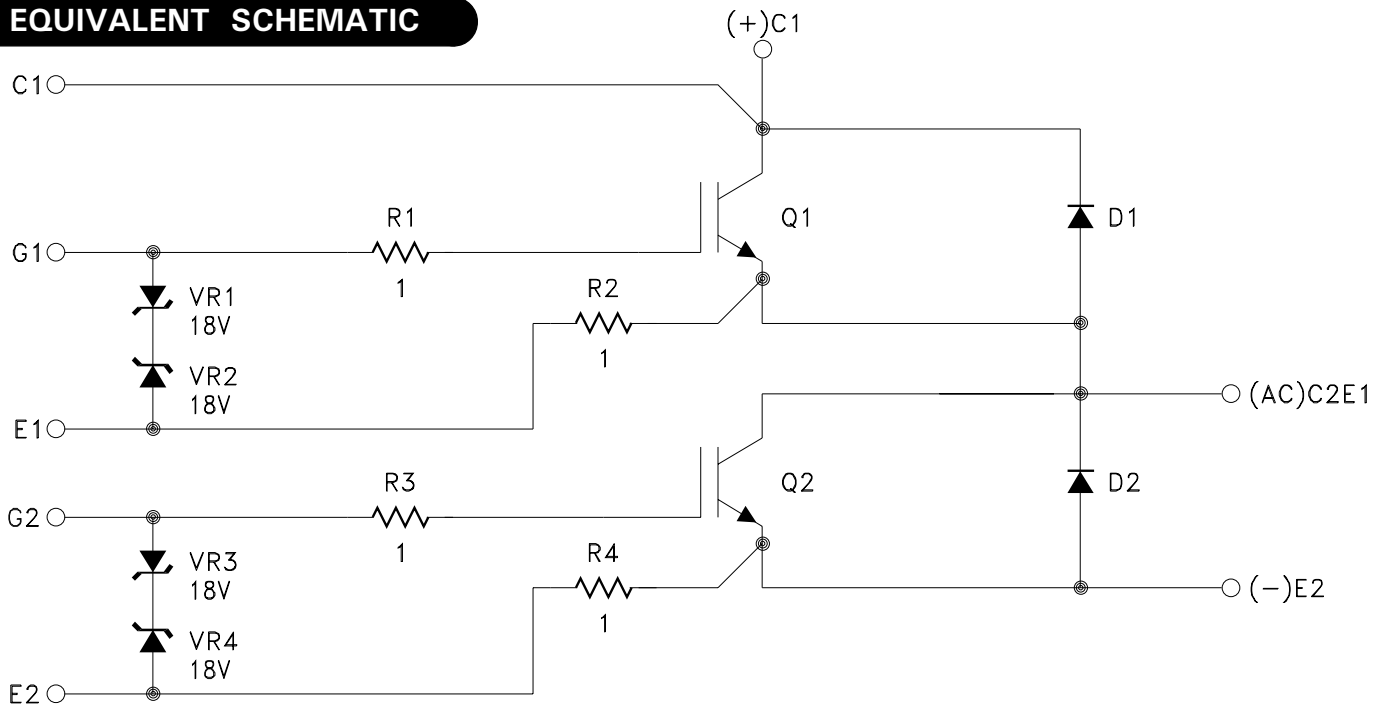

TYPICAL APPLICATIONS

- Motor Drives
- Inverters

ABSOLUTE MAXIMUM RATING ⑧

VCE Collector to Emitter Voltage 1200V
 VGE Gate to Emitter Voltage ± 20V
 IOUT Current (Continuous) 450A
 IOUTP Current Pulsed (1mS) 900A
 VCASE Case Isolation Voltage 2500 V

TST Storage Temperature Range . . . -55°C to +125°C
 TJ Junction Temperature 150°C
 TC Case Operating Temperature Range
 MSK 4810H/E -55°C to +125°C
 MSK 4810 -40°C to +85°C

ELECTRICAL SPECIFICATIONS

Parameter ⑥	Test Conditions	Group A Subgroup	MSK 4810 H/E			MSK 4810			Units
			Min.	Typ.	Max.	Min.	Typ.	Max.	
Collector-Emitter Saturation Voltage	IC = 450A, VGE = 15V	1	-	1.9	TBD	-	1.9	TBD	V
		2	-	1.8	TBD	-	1.8	TBD	V
		3	-	2.1	TBD	-	2.1	TBD	V
Collector-Emitter Leakage Current	VCE = 1200V, VGE = 0V	1	-	0.05	TBD	-	0.05	TBD	mA
		2	-	2.5	TBD	-	2.5	TBD	mA
		① 3	-	0.05	TBD	-	0.05	TBD	mA
Gate Threshold Voltage	IC = 45mA, VCE = VGE	1	TBD	5.3	TBD	TBD	5.3	TBD	V
		2	TBD	4.5	TBD	TBD	4.5	TBD	V
		3	TBD	6.0	TBD	TBD	6.0	TBD	V
Gate Leakage Current	VCE = 0V, VGE = ± 15V	1	TBD	0.2	TBD	TBD	0.2	TBD	uA
		2	TBD	0.4	TBD	TBD	0.4	TBD	uA
		3	TBD	0.1	TBD	TBD	0.1	TBD	uA
Diode Forward Voltage	IC = 450A	1	-	1.5	TBD	-	1.5	TBD	V
		2	-	1.3	TBD	-	1.3	TBD	V
		3	-	1.6	TBD	-	1.6	TBD	V
Total Gate Charge ①	V = 600V, IC = 450A	4	-	2500	TBD	-	2500	TBD	nC
Turn-On Delay ①	V = 600V, IC = 450A, RG = 20Ω	4	-	790	TBD	-	790	TBD	nS
Rise Time ①	V = 600V, IC = 450A, RG = 20Ω	4	-	400	TBD	-	400	TBD	nS
Turn-Off Delay ①	V = 600V, IC = 450A, RG = 10Ω	4	-	1.5	TBD	-	1.5	TBD	uS
Fall Time ①	V = 600V, IC = 450A, RG = 10Ω	4	-	120	TBD	-	120	TBD	nS
Diode Reverse Recovery Time ①	IE = 450A, di/dt = 900A/uS	4	-	75	TBD	-	75	TBD	nS
Diode Reverse Recovery Charge ①	IE = 450A, di/dt = 900A/uS	4	-	1.6	TBD	-	1.6	TBD	uC
Thermal Resistance ①	IGBT @ TJ = 125°C	4	-	0.06	TBD	-	0.06	TBD	°C/W
	DIODE @ TJ = 125°C	4	-	0.1	TBD	-	0.1	TBD	°C/W

NOTES:

- ① Guaranteed by design but not tested. Typical parameters are representative of actual device performance but are for reference only.
- ② Industrial grade and "E" suffix devices shall be tested to subgroup 1 unless otherwise specified.
- ③ Military grade devices ("H" suffix) shall be 100% tested to subgroups 1, 2 and 3.
- ④ Subgroups 4, 5 and 6 testing available upon request.
- ⑤ Subgroup 1, 4 TA = +25°C
 2, 5 TA = +125°C
 3, 6 TA = -55°C
- ⑥ All specifications apply to both the upper and lower sections of the half bridge.
- ⑦ VGE = 15V unless otherwise specified.
- ⑧ Continuous operation at or above absolute maximum ratings may adversely effect the device performance and/or life cycle

TYPICAL PERFORMANCE CURVES

TBD

SCREENING CHART

OPERATION IN ACCORDANCE WITH MIL-PRF-38534	INDUSTRIAL	CLASS E	CLASS H
QUALIFICATION (MODIFIED)	NO	NO	YES
ELEMENT EVALUATION	NO	YES	YES
CLEAN ROOM PROCESSING	YES	YES	YES
NON DESTRUCT BOND PULL SAMPLE	YES	YES	YES
CERTIFIED OPERATORS	NO	YES	YES
MIL LINE PROCESSING	YES	YES	YES
MAX REWORK SPECIFIED	NO	YES	YES
ENCAPSULANT	GEL COAT	SEES™	SEES™
PRE-CAP VISUAL	YES - INDUSTRIAL	YES - CLASS H	YES - CLASS H
TEMP CYCLE (-55°C TO +125°C)	NO	YES	YES
BURN-IN	NO	YES - 96 HOURS	YES - 160 HOURS
ELECTRICAL TESTING	YES - 25°C	YES - 25°C	YES - FULL TEMP
EXTERNAL VISUAL	YES - SAMPLE	YES - SAMPLE	YES
XRAY	NO	NO	NO
PIN FINISH	NI	NI	NI

NOTE: ADDITIONAL SCREENING IS AVAILABLE SUCH AS XRAY, CSAM, HAST, MECHANICAL SHOCK, ETC. CONTACT FACTORY FOR QUAL STATUS.

