

Class AB Stereo Headphone Driver with Shutdown

DESCRIPTION

The EUA5544 is pin compatible with the BH3541/4, and functionally compatible with the TPA611x series and LM488x series. As the EUA5544 contains advanced depop circuitry which eliminates pops & clicks during shutdown-on and shutdown-off, it can reduce a capacitor and resistor compared to Mute solution of other devices. The EUA5544 features an advantage of low-power consumption shutdown mode, activated by driving the shutdown pin with logic low. And it also allows fast turn-on with 1 μ F bypass capacitor (C_B).

The EUA5544 is an integrated class AB stereo headphone amplifier capable of delivering 68mW per channel of continuous average power into a 16 Ω load or 35mW per channel into a 32 Ω load from a 5V power supply. It also can operate from a 3V supply, capable of delivering 24 mW into a 32 Ω load.

The EUA5544 further integrates a voltage divider inside the chip. Thus, the external resistors can be eliminated. The EUA5544 has a fixed gain of 6dB so that external gain setting is unnecessary.

FEATURES

- No Switch On/Off Clicks
- Wide Power Supply Operation 2.5V– 6V
- Mute Function Compatibility
- High Signal-to-Noise Ratio
- Low Distortion
- Large Output Voltage Swing
- Excellent Power Supply Ripple Rejection
- High Crosstalk Immunity > 85dB
- Low Quiescent Current
- Ultra-low Shutdown Current ...0.02 μ A typical
- Short-circuit Protection
- Integrated Voltage Divider ($V_{DD}/2$) to Eliminate External Resistors
- Available in SOP-8

APPLICATIONS

- Headphone Amplifier for CD-ROMs
- Portable Audio Equipment

Typical Application Circuit

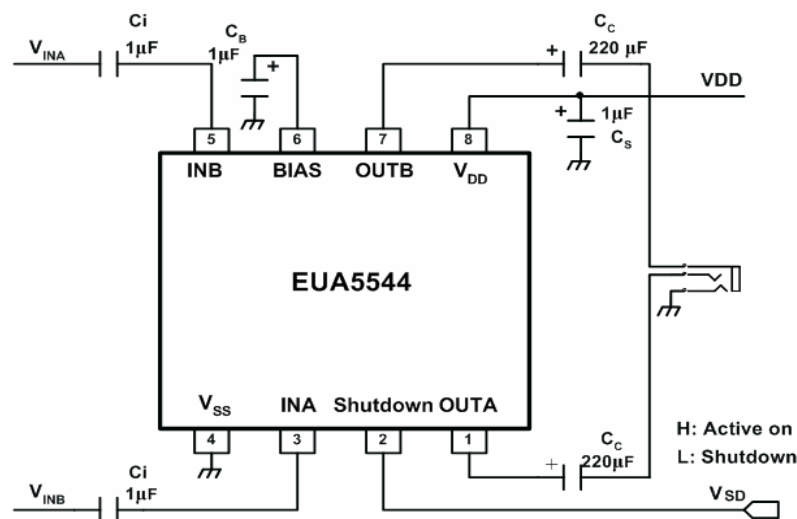

Pin Configurations

Part Number	Pin Configurations
EUA5544 (Plastic SOP-8)	<p style="text-align: center;">TOP VIEW</p>

Pin Description

PIN	I/O	DESCRIPTION
OUTA	O	A channel output pin
Shutdown	I	Chip disable control input, low active and high for normal operating
INA	I	A channel input terminal
V _{SS}		Power ground pin
INB	I	B channel input terminal
BIAS	I	Right channel bias input pin
OUTB	O	B channel output pin
V _{DD}		Power input pin

Block Diagram

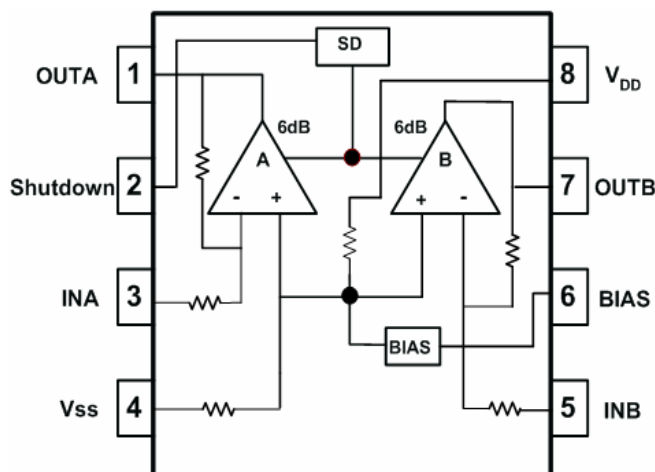

Ordering Information

Order Number	Package Type	Marking	Operating Temperature range
EUA5544SIR	SOP-8	 xxxx EUA5544	-40 °C to 85°C

EUA5544

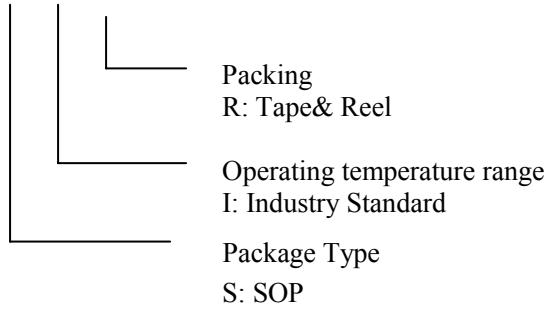

Absolute Maximum Ratings

Input voltage -----	7V
Maximum Junction Temperature -----	150°C
Storage Temperature Range -----	-60°C to 150°C
Power Dissipation P_D (@) $T_A=25$ °C	
DIP-8 -----	1.25W
SOP-8 -----	0.625W
Package Thermal Resistance	
SOP-8, θ_{JA} -----	160°C /W
Electrostatic Discharge -----	-3000 to 3000V ⁽¹⁾ -200 to 200V ⁽²⁾

Notes: (1) Human body mode: C=100pF, R=1500Ω, 3 positive pulses plus 3 negative pulses
 (2) Machine mode: C=200pF, L=0.5mH, R=0Ω, 3 positive pulses plus 3 negative pulses

Electrical Characteristics VDD = 5V

$V_{in} = -6$ dBV, $R_L = 32\Omega$, $f = 1$ KHz, $C_B = 1\mu F$, $T_A = 25$ °C (unless otherwise specified)

Symbol	Parameter	Conditions	EUA5544			Unit
			Min.	Typ.	Max.	
VDD	Supply Voltage		2.5	5.0	6.0	V
IQ	Quiescent Current	$V_{in} = 0V$		3.5	5	mA
ISD	Shutdown Current	VSD = GND		0.02		μA
VSDIH	Shutdown Voltage Input High			1.8		V
VSDIL	Shutdown Voltage Input Low			0.4		V
GVCL	Differential Channel Voltage Gain		-0.5	0	0.5	dB
GVCL	Voltage Gain		4	6	8	dB
THD+N	Total Harmonic Distortion plus Noise	BW < 80KHz		0.02	0.1	%
Po	Output Power	$R_L = 32\Omega$, THD+N < 0.1%, BW < 80KHz		31		mW
		$R_L = 16\Omega$, THD+N < 0.1%, BW < 80KHz		62		mW
VN	Output Noise Voltage	BW = 20~20KHz		-95		dBV
CS	Channel Separation	$f = 20\sim 20$ KHz		90		dB
ATT	Shutdown Attenuation	$V_{in} = 1V$, SD = Low		70		dB
PSRR	Ripple Rejection	$F_{RR}=100$ Hz, $V_{RR} = -20$ dBV	55	60		dB

Electrical Characteristics VDD = 3.0V

$V_{in} = -6\text{dBV}$, $R_L = 32\Omega$, $f = 1\text{KHz}$, $C_B = 1\mu\text{F}$, $T_A = 25^\circ\text{C}$ (unless otherwise specified)

Symbol	Parameter	Conditions	EUA5544			Unit
			Min.	Typ.	Max.	
IQ	Quiescent Current	$V_{in} = 0\text{V}$		2.4	3	mA
ISD	Shutdown Current	$V_{SD} = \text{GND}$		0.02		μA
Po	Output Power	$R_L = 32\Omega$, THD+N < 0.1%, BW < 80KHz		24		mW
		$R_L = 16\Omega$, THD+N < 0.1%, BW < 80KHz		37		mW
VN	Output Noise Voltage	BW = 20 20KHz	-95	-94		dBV
PSRR	Ripple Rejection	$F_{RR}=100\text{Hz}$, $V_{RR} = -20\text{dBV}$	55	60		dB

Electrical Characteristics VDD = 2.5V

$V_{in} = -6\text{dBV}$, $R_L = 32\Omega$, $f = 1\text{KHz}$, $C_B = 1\mu\text{F}$, $T_A = 25^\circ\text{C}$ (unless otherwise specified)

Symbol	Parameter	Conditions	EUA5544			Unit
			Min.	Typ.	Max.	
IQ	Quiescent Current	$V_{in} = 0\text{V}$		2.2	3	mA
ISD	Shutdown Current	$V_{SD} = \text{GND}$		0.02		μA
Po	Output Power	$R_L = 32\Omega$, THD+N < 0.1%, BW < 80KHz		17		mW
		$R_L = 16\Omega$, THD+N < 0.1%, BW < 80KHz		22		mW
VN	Output Noise Voltage	BW = 20~20KHz		-94		dBV
PSRR	Ripple Rejection	$F_{RR}=100\text{Hz}$, $V_{RR} = -20\text{dBV}$		60		dB

Typical Operating Characteristics

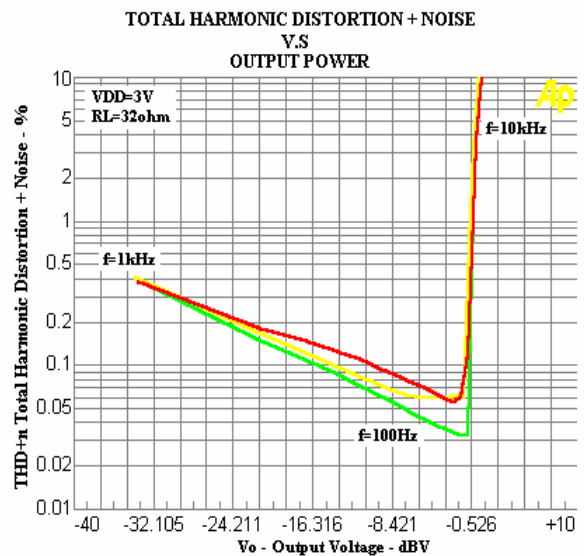
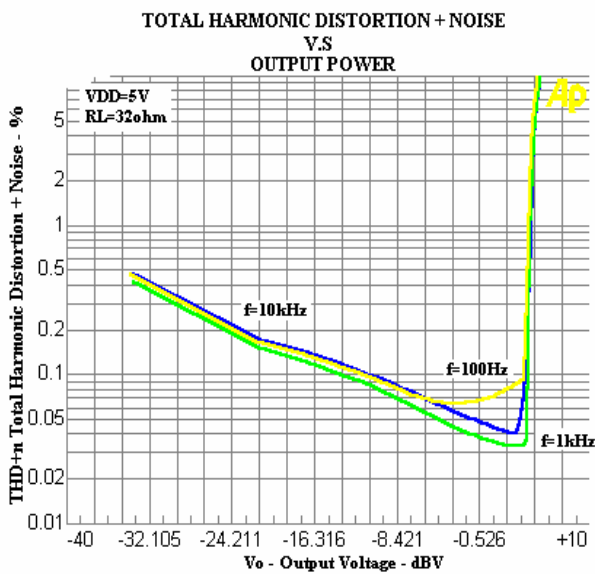
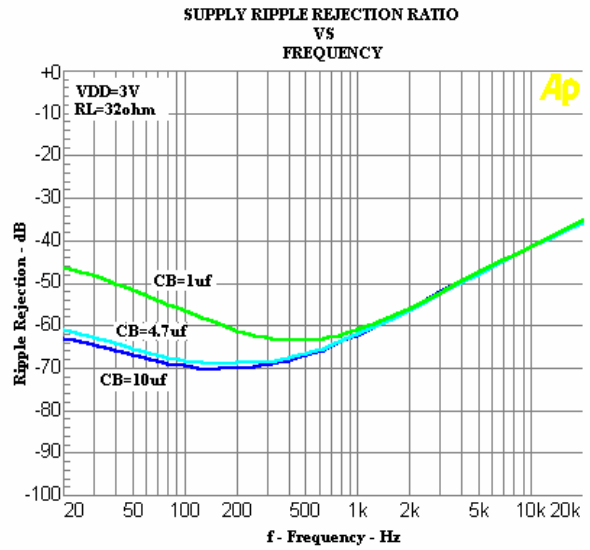
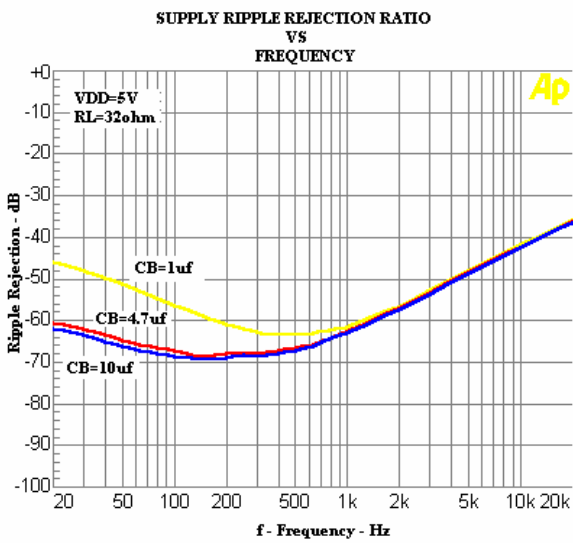

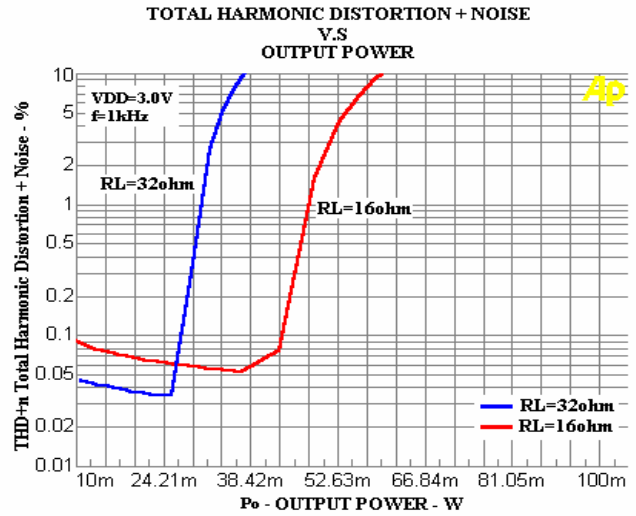
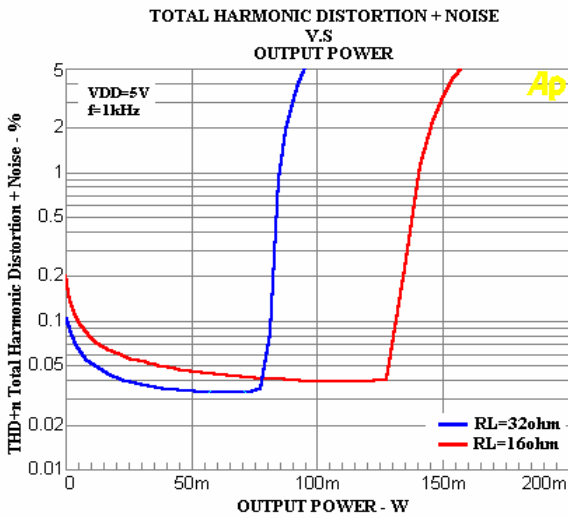
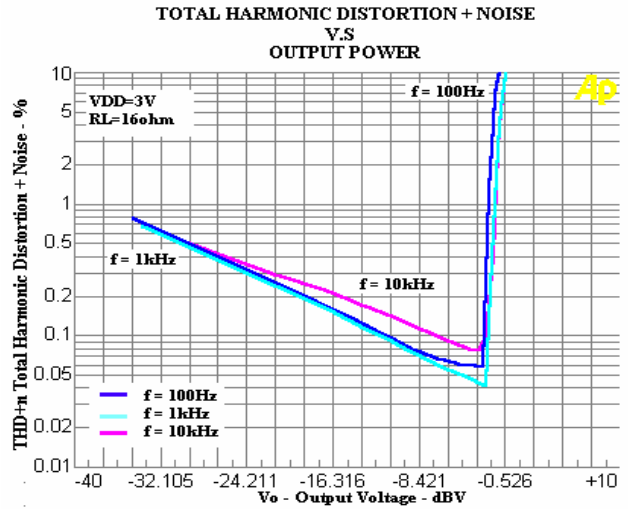
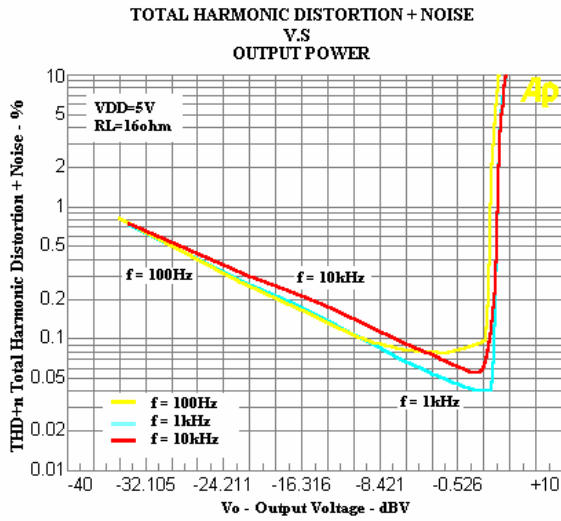

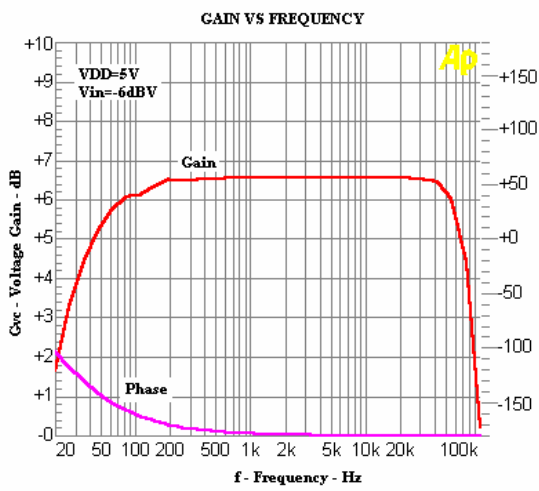
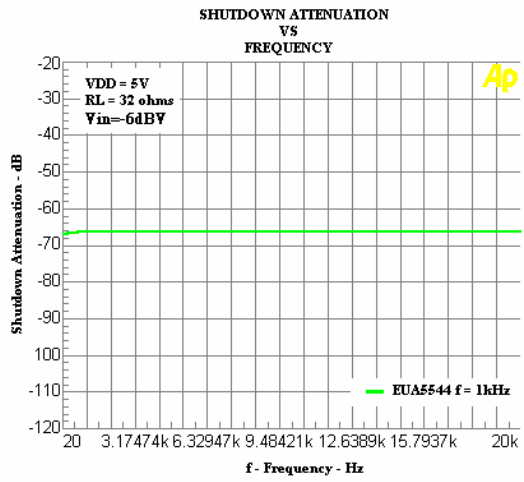
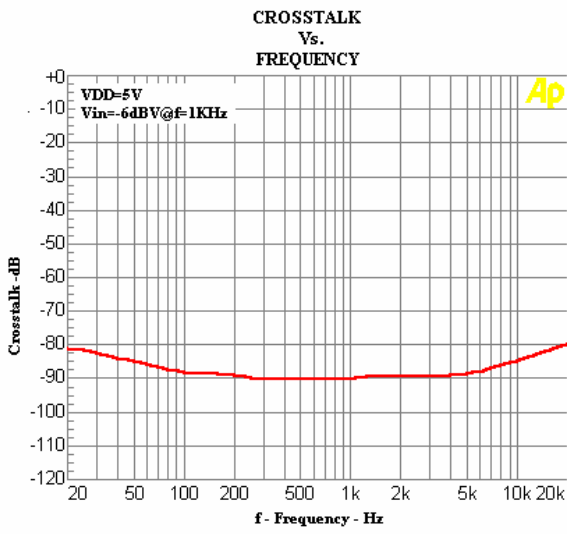

Application Note

Power Supply Decoupling, C_S

EUA5544 is a high-performance CMOS audio amplifier that requires adequate power supply decoupling to ensure the output total harmonic distortion (THD) is as low as possible. Power supply decoupling also prevents the oscillations causing by long lead length between the amplifier and the speaker.

Applications that employ a 5V regulator typically use a 10 μ F in parallel with a 0.1 μ F filter capacitors to stabilize the regulator's output, reduce noise on the supply line, and improve the supply's transient response. However, this does not eliminate the need for a local bypass capacitor connected between the EUA5544's supply pins and ground. A bypass capacitor value in the range of 0.1 μ F to 1 μ F is recommended for C_S .

Input Capacitor C_i

Amplifying the lowest audio frequencies requires a high value input coupling capacitor, C_i . A high value capacitor can be expensive and may compromise space efficiency in portable designs. In many cases, however, the headphones used in portable systems have little ability to reproduce signals below 60Hz. Applications using headphones with this limited frequency response reap little improvement by using a high value input capacitor.

In addition to system cost and size, turn-on time is affected by the size of the input coupling capacitor C_i . A larger input coupling capacitor requires more charge to reach its quiescent DC voltage. This charge comes from the output via the feedback. Thus, by minimizing the capacitor size based on necessary low frequency response, turn-on time can be minimized. A small value of C_i , 1 μ F, is recommended.

Bypass Capacitor, C_B

Besides minimizing the input capacitor sizes, careful consideration should be paid to the bypass capacitor size. The bypass capacitor, C_B , is the most critical component to minimize turn-on pops since it determines how fast the EUA5544 turns on. The slower the EUA5544's output ramp to their quiescent DC voltage (nominally $1/2 V_{DD}$), the smaller the turn-on pop. Thus, a value of C_B equal to 1.0 μ F or larger is recommended in all but the most cost sensitive designs.

Output Coupling Capacitors, C_c

Typical single-supply audio amplifiers that drive single-ended (SE) headphones use a coupling capacitor on each SE output. This output coupling capacitor blocks the half-supply voltage to which the output amplifiers are typically biased and couples the audio signal to the headphones.

The output coupling capacitor and impedance of the load form a high-pass filter governed by equation.

$$f_c(\text{highpass})=1/(2\pi R_L C_C) \quad (4)$$

For example, a 220 μ F capacitor with an 32 Ω speaker would attenuate low frequencies below 22Hz. The main disadvantage, from a performance standpoint, is the load impedance is typically small, which drives the low-frequency corner higher degrading the bass response. Large values of C_C are required to pass low frequencies into the load.

Micro Power Shutdown

The voltage applied to the Shutdown pin controls the EUA5544 shutdown function. Activate micro-power shutdown by applying a logic-low voltage to the Shutdown pin. When active, the EUA5544 micro-power shutdown feature turns off the amplifier's bias circuitry, reducing the supply current.

There are a few ways to control the micro-power shutdown. These include using a single-pole, single-throw (SPST) switch, a microprocessor, or a microcontroller. When using a switch, connect an external pull-up resistor between the Shutdown pin and V_{DD} . Connect the switch between the Shutdown pin and ground. Select normal amplifier operation by opening the switch. Closing the switch connects the Shutdown pin to ground, activating micro-power shutdown. The switch and resistor guarantee that the Shutdown pin will not float. This prevents unwanted state changes. In a system with a microprocessor or microcontroller, use a digital output to apply the control voltage to the Shutdown pin.

Packaging Information

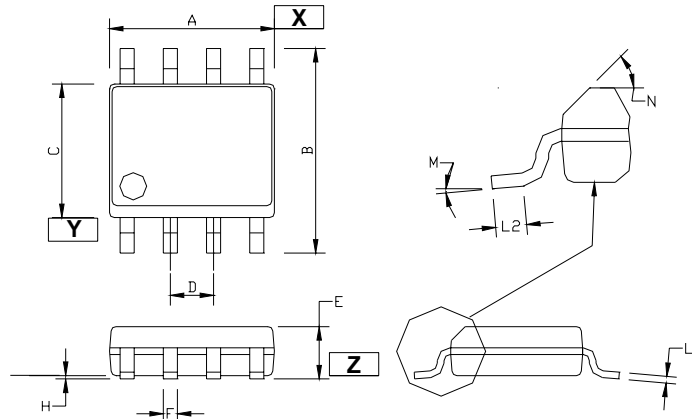

Standard Solder Map

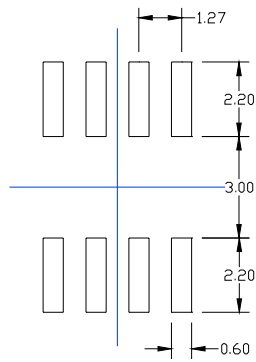

Symbols	Dimension in Millimeters		Dimension in Inches	
	Min.	Max.	Min.	Max.
A	4.80	5.00	0.189	0.197
B	5.80	6.20	0.228	0.244
C	3.80	4.00	0.150	0.157
D	1.194	1.346	0.047	0.053
E	1.45	1.55	0.057	0.061
H	0.00	0.10	0.000	0.004
F	0.33	0.51	0.013	0.020
L1	0.19	0.25	0.007	0.010
L2	0.40	1.27	0.016	0.050
M	0°	8°	0°	8°
N	40°	50°	40°	50°

8 – Lead SOP Plastic Package