

CGH40025F

25 W, RF Power GaN HEMT

Cree's CGH40025 is an unmatched, gallium nitride (GaN) high electron mobility transistor (HEMT). The CGH40025, operating from a 28 volt rail, offers a general purpose, broadband solution to a variety of RF and microwave applications. GaN HEMTs offer high efficiency, high gain and wide bandwidth capabilities making the CGH40025 ideal for linear and compressed amplifier circuits. The transistor is available in a screw-down, flange package.



Package Type: 440166
PN: CGH40025F

FEATURES

- Up to 4 GHz Operation
- 16 dB Small Signal Gain at 2.0 GHz
- 13 dB Small Signal Gain at 4.0 GHz
- 30 W typical P_{3dB}
- 62 % Efficiency at P3dB
- 28 V Operation

APPLICATIONS

- 2-Way Private Radio
- Broadband Amplifiers
- Cellular Infrastructure
- Test Instrumentation
- Class A, AB, Linear amplifiers suitable for OFDM, W-CDMA, EDGE, CDMA waveforms





Absolute Maximum Ratings (not simultaneous) at 25 °C Case Temperature

Parameter	Symbol	Rating	Units
Drain-Source Voltage	V_{DSS}	84	Volts
Gate-to-Source Voltage	V_{GS}	-10, +2	Volts
Storage Temperature	T_{STG}	-55, +150	°C
Operating Junction Temperature	T_J	175	°C
Maximum Forward Gate Current	I_{GMAX}	4.0	mA
Soldering Temperature	T_S	245	°C
Thermal Resistance, Junction to Case ¹	$R_{\theta JC}$	3.8	°C/W

Note:

¹ Measured for the CGH40025F at $P_{DISS} = 28$ W.

Electrical Characteristics ($T_c = 25^\circ\text{C}$)

Characteristics	Symbol	Min.	Typ.	Max.	Units	Conditions
DC Characteristics²						
Gate Threshold Voltage	$V_{GS(th)}$	-3.0	-2.5	-1.8	VDC	$V_{DS} = 10$ V, $I_D = 7.2$ mA
Gate Quiescent Voltage	$V_{GS(Q)}$	-	-2.0	-	VDC	$V_{DS} = 28$ V, $I_D = 250$ mA
Saturated Drain Current	I_{DS}	4.8	5.4	-	A	$V_{DS} = 6.0$ V, $V_{GS} = 2.0$ V
Drain-Source Breakdown Voltage	V_{BR}	84	100	-	VDC	$V_{GS} = -8$ V, $I_D = 7.2$ mA
Case Operating Temperature	T_c	-10	-	+65	°C	
Screw Torque	T	-	-	60	in-oz	Reference 440166 Package Revision 3
RF Characteristics ($T_c = 25^\circ\text{C}$, $F_0 = 3.7$ GHz unless otherwise noted)						
Small Signal Gain	G_{SS}	-	13	-	dB	$V_{DD} = 28$ V, $I_{DQ} = 250$ mA
Power Output at 3 dB Compression	P_{3dB}	-	30	-	W	$V_{DD} = 28$ V, $I_{DQ} = 250$ mA
Drain Efficiency ¹	η	-	62	-	%	$V_{DD} = 28$ V, $I_{DQ} = 250$ mA, P_{3dB}
Output Mismatch Stress	VSWR	-	TBD	-	Ψ	No damage at all phase angles, $V_{DD} = 28$ V, $I_{DQ} = 250$ mA, $P_{OUT} = 12$ W CW
Dynamic Characteristics						
Input Capacitance	C_{GS}	-	9.3	-	pF	$V_{DS} = 28$ V, $V_{gs} = -8$ V, $f = 1$ MHz
Output Capacitance	C_{DS}	-	2.0	-	pF	$V_{DS} = 28$ V, $V_{gs} = -8$ V, $f = 1$ MHz
Feedback Capacitance	C_{GD}	-	0.9	-	pF	$V_{DS} = 28$ V, $V_{gs} = -8$ V, $f = 1$ MHz

Notes:

¹ Drain Efficiency = P_{OUT} / P_{DC}

² Measured on wafer prior to packaging.



Typical Performance

P3dB, Gain, and Drain Efficiency vs Frequency of the CGH40025F in the CGH40025-TB
 $V_{DD} = 28\text{ V}$, $I_{DQ} = 250\text{ mA}$

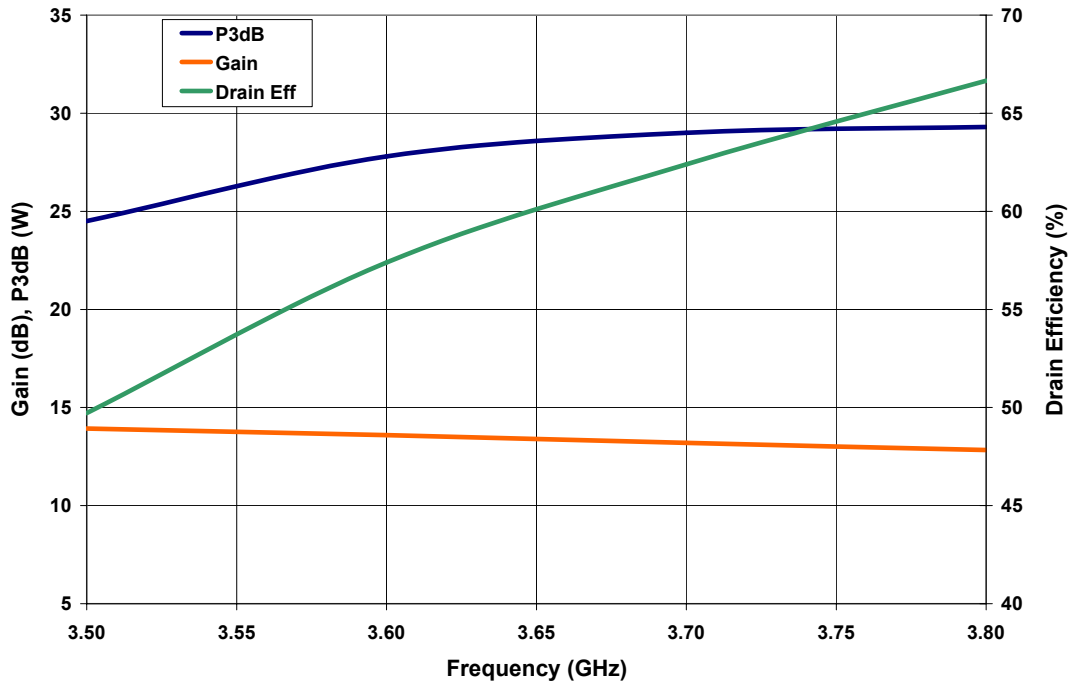

Small Signal Gain and Return Loss vs Frequency of the CGH40025F in the CGH40025-TB

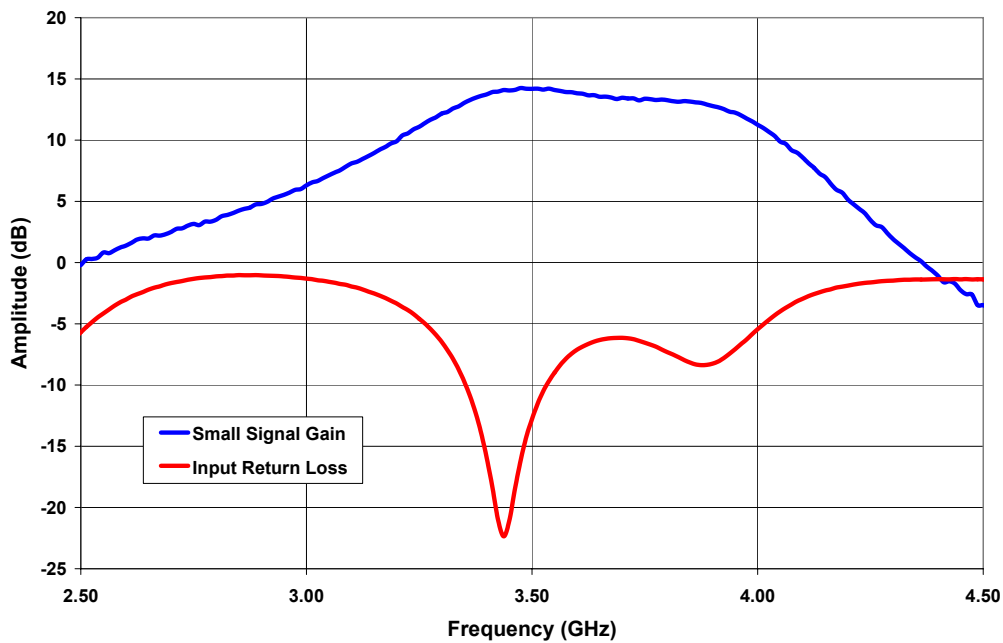



Typical Performance

Swept CW Data of CGH40025F vs. Output Power with Source and Load Impedances Optimized for P3dB Power in CGH40025F-TB
 $V_{DD} = 28\text{ V}$, $I_{DQ} = 250\text{ mA}$, Freq = 3.7 GHz

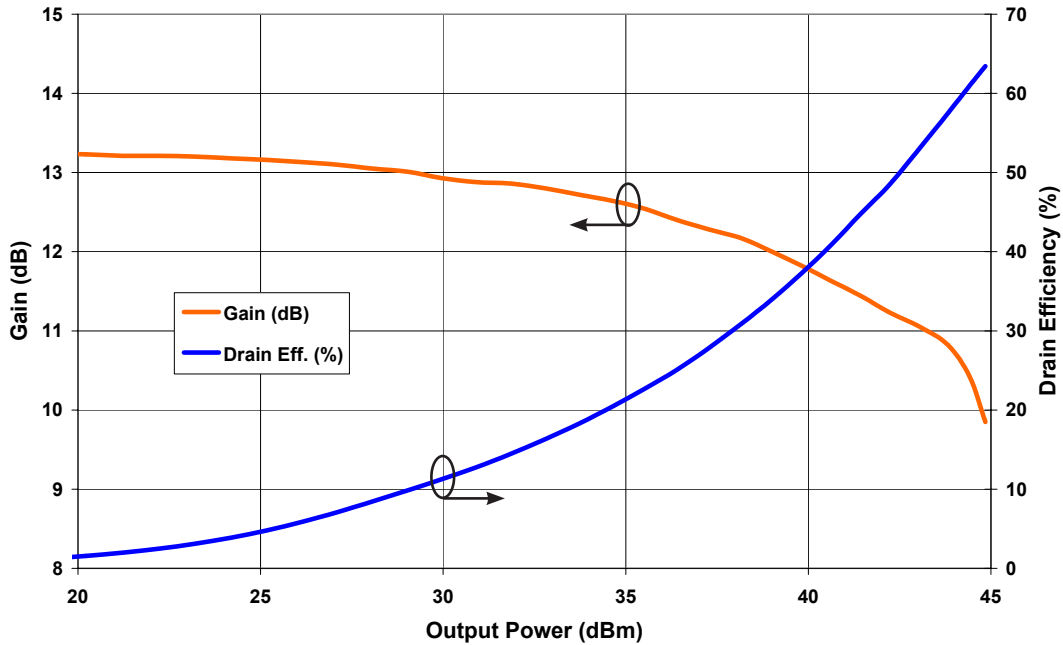

Simulated Maximum Stable Gain, Maximum Available Gain and K Factor of the CGH40025F
 $V_{DD} = 28\text{ V}$, $I_{DQ} = 250\text{ mA}$

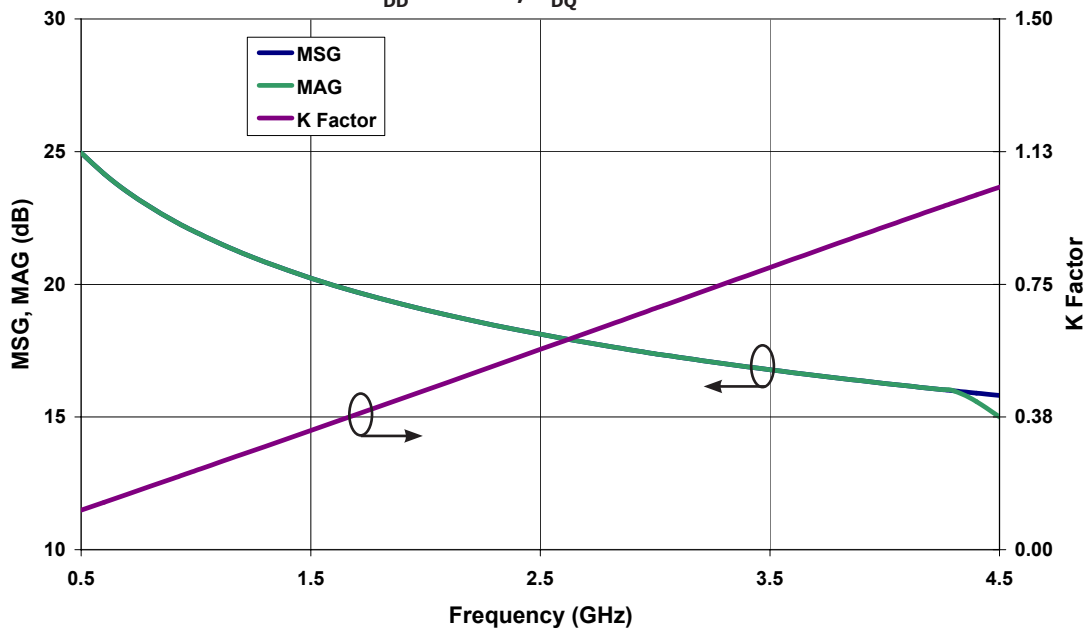

Source and Load Impedances

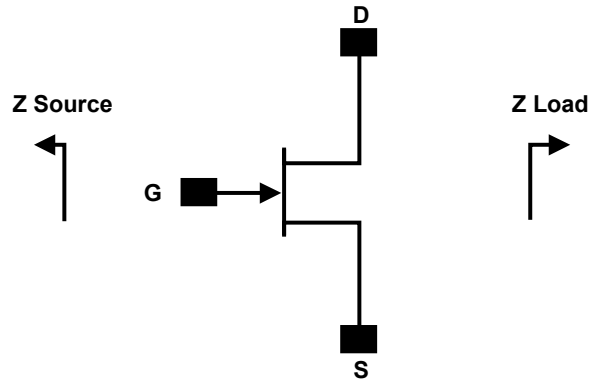

Frequency (MHz)	Z Source	Z Load
500	2.0 + j 12.5	10.9 + j 1.2
1000	2.0 + j 11.8	10.7 + j 4.2
1500	1.9 + j 1.0	9.2 + j 1.7
2500	2.1 - j 5.4	8.7 - j 1.7
3500	2.2 - j 9.7	6.5 - j 4.3

Note 1. $V_{DD} = 28V$, $I_{DQ} = 200mA$ in the 440166 package.

Note 2. Optimized for P_{1dB} and Efficiency

Note 3. When using this device at low frequency, series resistors should be used to maintain amplifier stability.

CGH40025F Power Dissipation De-rating Curve

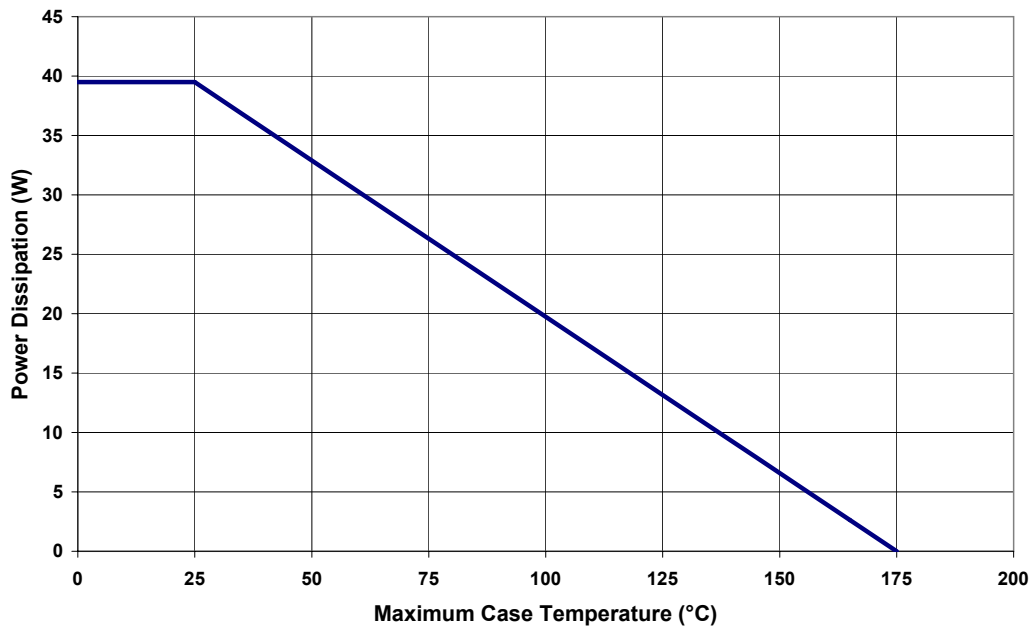

CGH40025F-TB Demonstration Amplifier Circuit Schematic

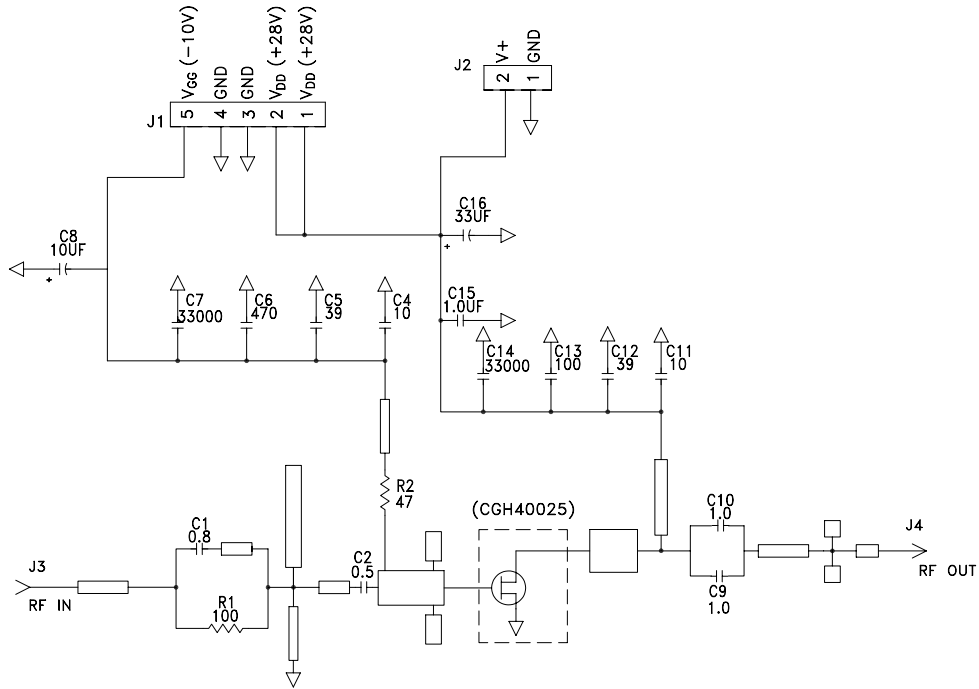

CGH40025F-TB Demonstration Amplifier Circuit Outline

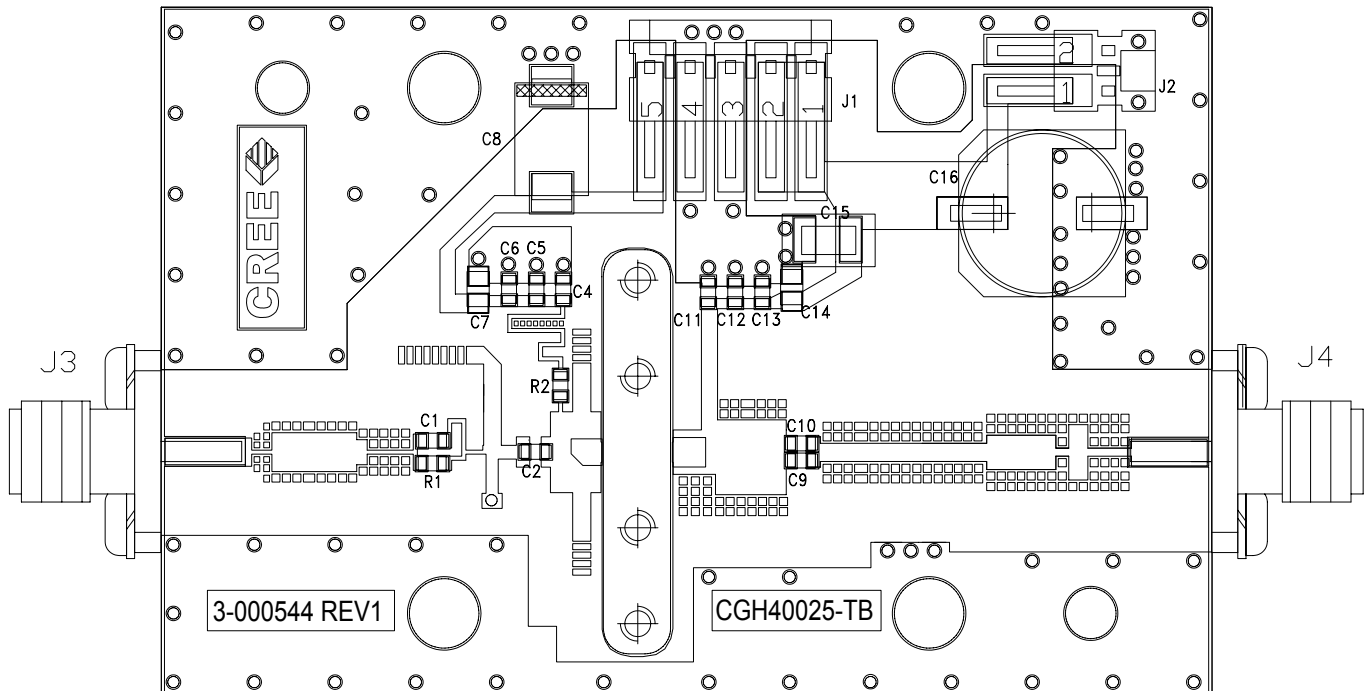

CGH40025F-TB Demonstration Amplifier Circuit Bill of Materials

Designator	Description	Qty
R2	RES,1/16W,0603,1%,47 OHMS	1
R1	RES,1/16W,0603,1%,100 OHMS	1
C6	CAP, 470PF, 5%,100V, 0603	1
C16	CAP, 33 UF, 20%, G CASE	1
C15	CAP, 1.0UF, 100V, 10%, X7R, 1210	1
C8	CAP 10UF 16V TANTALUM	1
C13	CAP, 100.0pF, +/-5%, 0603	1
C1	CAP, 0.8pF, +/-0.1pF, 0603	1
C2	CAP, 0.5pF, +/-0.1pF, 0603	1
C9,C10	CAP, 1.0pF, +/-0.1pF, 0603	2
C4,C11	CAP, 10.0pF,+/-5%, 0603	2
C5,C12	CAP, 39pF, +/-5%, 0603	2
C7,C14	CAP,33000PF, 0805,100V, X7R	2
J3,J4	CONN SMA STR PANEL JACK RECP	2
J2	HEADER RT>PLZ.1CEN LK 2 POS	1
J1	HEADER RT>PLZ .1CEN LK 5POS	1
Q1	CGH40025F	1

CGH40025F-TB Demonstration Amplifier Circuit

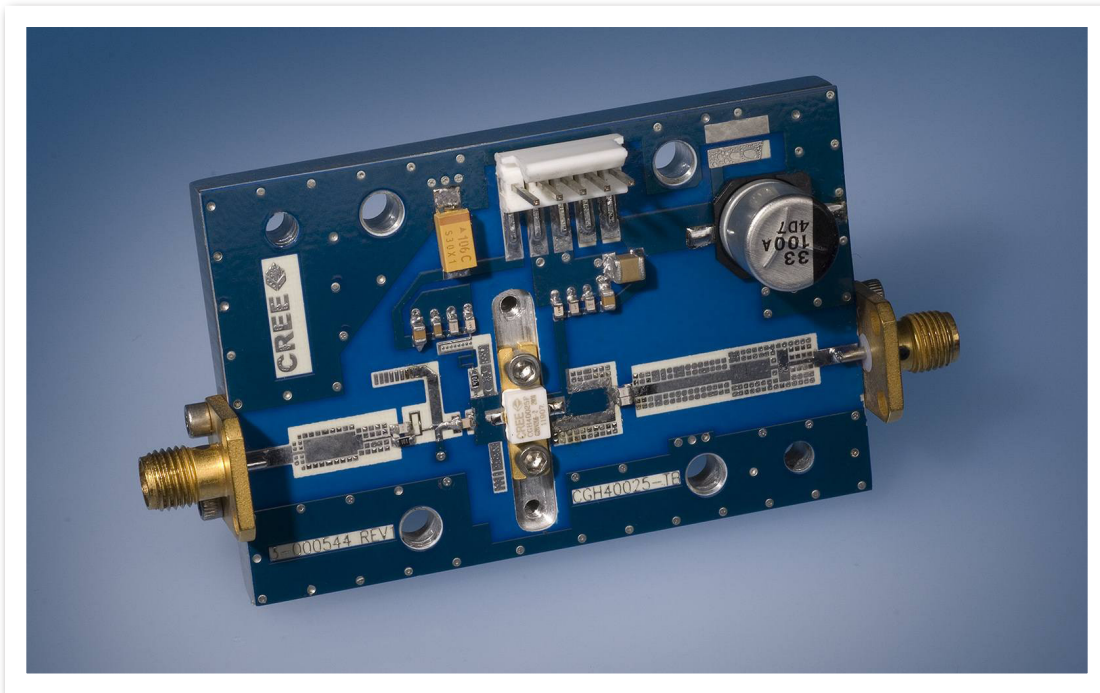



Typical Package S-Parameters for CGH40025F
(Small Signal, $V_{DS} = 28\text{ V}$, $I_{DQ} = 100\text{ mA}$, angle in degrees)

Frequency	Mag S11	Ang S11	Mag S21	Ang S21	Mag S12	Ang S12	Mag S22	Ang S22
500 MHz	0.9146	-163.11	6.86	90.44	0.0345	3.57	0.6445	-169.55
600 MHz	0.9139	-167.05	5.74	87.04	0.0346	0.80	0.6481	-171.68
700 MHz	0.9136	-170.07	4.93	84.08	0.0346	-1.53	0.6508	-173.28
800 MHz	0.9135	-172.50	4.32	81.41	0.0346	-3.56	0.6531	-174.56
900 MHz	0.9134	-174.55	3.84	78.93	0.0345	-5.41	0.6553	-175.61
1.0 GHz	0.9135	-176.32	3.46	76.58	0.0344	-7.12	0.6574	-176.52
1.1 GHz	0.9136	-177.89	3.14	74.34	0.0344	-8.72	0.6595	-177.32
1.2 GHz	0.9138	-179.31	2.88	72.17	0.0343	-10.25	0.6616	-178.05
1.3 GHz	0.9140	-179.38	2.66	70.07	0.0341	-11.71	0.6638	-178.72
1.4 GHz	0.9142	-178.15	2.47	68.01	0.0340	-13.11	0.6660	-179.35
1.5 GHz	0.9145	-177.00	2.30	65.99	0.0339	-14.47	0.6684	-179.96
1.6 GHz	0.9148	-175.90	2.16	64.01	0.0337	-15.80	0.6708	-179.46
1.7 GHz	0.9151	-174.85	2.03	62.06	0.0336	-17.09	0.6732	-178.89
1.8 GHz	0.9154	-173.83	1.91	60.14	0.0334	-18.34	0.6758	-178.33
1.9 GHz	0.9157	-172.84	1.81	58.24	0.0332	-19.57	0.6783	-177.77
2.0 GHz	0.9160	-171.87	1.72	56.36	0.0331	-20.78	0.6810	-177.22
2.1 GHz	0.9164	-170.93	1.64	54.50	0.0329	-21.95	0.6837	-176.66
2.2 GHz	0.9167	-169.99	1.56	52.65	0.0327	-23.11	0.6864	-176.10
2.3 GHz	0.9171	-169.07	1.49	50.82	0.0325	-24.24	0.6891	-175.53
2.4 GHz	0.9174	-168.17	1.43	49.01	0.0323	-25.35	0.6919	-174.96
2.5 GHz	0.9178	-167.26	1.37	47.21	0.0321	-26.44	0.6947	-174.38
2.6 GHz	0.9182	-166.37	1.32	45.43	0.0319	-27.51	0.6975	-173.79
2.7 GHz	0.9185	-165.47	1.27	43.65	0.0316	-28.56	0.7003	-173.19
2.8 GHz	0.9189	-164.58	1.22	41.89	0.0314	-29.58	0.7031	-172.58
2.9 GHz	0.9192	-163.69	1.18	40.14	0.0312	-30.59	0.7059	-171.96
3.0 GHz	0.9196	-162.80	1.14	38.40	0.0310	-31.58	0.7086	-171.33
3.1 GHz	0.9199	-161.91	1.10	36.67	0.0308	-32.54	0.7114	-170.68
3.2 GHz	0.9202	-161.01	1.07	34.95	0.0305	-33.49	0.7141	-170.03
3.3 GHz	0.9205	-160.12	1.04	33.24	0.0303	-34.41	0.7168	-169.36
3.4 GHz	0.9209	-159.21	1.01	31.54	0.0301	-35.32	0.7194	-168.68
3.5 GHz	0.9211	-158.30	0.98	29.85	0.0298	-36.21	0.7220	-167.98
3.6 GHz	0.9214	-157.39	0.95	28.16	0.0296	-37.07	0.7246	-167.27
3.7 GHz	0.9217	-156.47	0.93	26.48	0.0294	-37.92	0.7271	-166.55
3.8 GHz	0.9220	-155.54	0.90	24.80	0.0292	-38.74	0.7296	-165.82
3.9 GHz	0.9222	-154.60	0.88	23.14	0.0289	-39.54	0.7320	-165.07
4.0 GHz	0.9224	-153.66	0.86	21.47	0.0287	-40.33	0.7344	-164.31
4.1 GHz	0.9226	-152.70	0.84	19.81	0.0285	-41.09	0.7367	-163.53
4.2 GHz	0.9228	-151.74	0.82	18.16	0.0283	-41.83	0.7389	-162.74
4.3 GHz	0.9230	-150.77	0.80	16.51	0.0280	-42.55	0.7411	-161.94
4.4 GHz	0.9232	-149.78	0.79	14.86	0.0278	-43.24	0.7432	-161.12
4.5 GHz	0.9233	-148.78	0.77	13.22	0.0276	-43.92	0.7453	-160.28



Typical Package S-Parameters for CGH40025F
 (Small Signal, $V_{DS} = 28\text{ V}$, $I_{DQ} = 250\text{ mA}$, angle in degrees)

Frequency	Mag S11	Ang S11	Mag S21	Ang S21	Mag S12	Ang S12	Mag S22	Ang S22
500 MHz	0.9320	-166.46	7.34	90.67	0.0235	5.13	0.7427	-175.59
600 MHz	0.9315	-169.94	6.14	87.83	0.0236	3.18	0.7450	-177.26
700 MHz	0.9312	-172.64	5.28	85.36	0.0236	1.61	0.7465	-178.60
800 MHz	0.9310	-174.83	4.63	83.13	0.0236	0.28	0.7475	-179.75
900 MHz	0.9309	-176.70	4.12	81.06	0.0236	-0.88	0.7483	179.24
1.0 GHz	0.9308	-178.34	3.71	79.11	0.0236	-1.93	0.7489	178.33
1.1 GHz	0.9307	-179.81	3.38	77.23	0.0236	-2.89	0.7495	177.48
1.2 GHz	0.9306	178.85	3.10	75.42	0.0236	-3.79	0.7499	176.68
1.3 GHz	0.9305	177.61	2.87	73.66	0.0236	-4.64	0.7503	175.92
1.4 GHz	0.9305	176.43	2.67	71.94	0.0236	-5.45	0.7507	175.19
1.5 GHz	0.9304	175.32	2.49	70.24	0.0236	-6.22	0.7511	174.47
1.6 GHz	0.9303	174.25	2.34	68.57	0.0236	-6.96	0.7515	173.78
1.7 GHz	0.9303	173.23	2.21	66.92	0.0236	-7.68	0.7518	173.09
1.8 GHz	0.9302	172.23	2.09	65.29	0.0236	-8.38	0.7522	172.42
1.9 GHz	0.9301	171.26	1.98	63.67	0.0236	-9.06	0.7525	171.75
2.0 GHz	0.9300	170.30	1.89	62.07	0.0236	-9.72	0.7529	171.09
2.1 GHz	0.9300	169.37	1.80	60.47	0.0236	-10.36	0.7532	170.43
2.2 GHz	0.9299	168.44	1.72	58.88	0.0236	-11.00	0.7536	169.78
2.3 GHz	0.9298	167.53	1.65	57.30	0.0236	-11.61	0.7539	169.12
2.4 GHz	0.9297	166.62	1.59	55.73	0.0236	-12.22	0.7542	168.46
2.5 GHz	0.9296	165.73	1.53	54.16	0.0236	-12.81	0.7546	167.80
2.6 GHz	0.9295	164.83	1.47	52.59	0.0236	-13.39	0.7549	167.14
2.7 GHz	0.9294	163.94	1.42	51.03	0.0236	-13.96	0.7552	166.47
2.8 GHz	0.9293	163.05	1.37	49.48	0.0236	-14.52	0.7556	165.80
2.9 GHz	0.9291	162.16	1.33	47.92	0.0236	-15.07	0.7559	165.13
3.0 GHz	0.9290	161.27	1.29	46.37	0.0236	-15.61	0.7562	164.45
3.1 GHz	0.9289	160.38	1.25	44.82	0.0236	-16.14	0.7565	163.76
3.2 GHz	0.9287	159.48	1.22	43.27	0.0236	-16.66	0.7568	163.07
3.3 GHz	0.9285	158.58	1.19	41.72	0.0236	-17.17	0.7570	162.37
3.4 GHz	0.9284	157.68	1.16	40.18	0.0236	-17.67	0.7573	161.66
3.5 GHz	0.9282	156.77	1.13	38.63	0.0237	-18.16	0.7575	160.94
3.6 GHz	0.9280	155.86	1.10	37.08	0.0237	-18.64	0.7578	160.22
3.7 GHz	0.9278	154.94	1.08	35.53	0.0237	-19.12	0.7580	159.48
3.8 GHz	0.9276	154.01	1.05	33.98	0.0238	-19.59	0.7582	158.74
3.9 GHz	0.9274	153.08	1.03	32.43	0.0238	-20.05	0.7583	157.99
4.0 GHz	0.9271	152.13	1.01	30.88	0.0238	-20.50	0.7585	157.23
4.1 GHz	0.9269	151.18	0.99	29.32	0.0239	-20.95	0.7586	156.45
4.2 GHz	0.9266	150.22	0.97	27.76	0.0239	-21.38	0.7587	155.67
4.3 GHz	0.9263	149.24	0.95	26.20	0.0240	-21.82	0.7588	154.87
4.4 GHz	0.9260	148.26	0.94	24.64	0.0241	-22.24	0.7588	154.07
4.5 GHz	0.9257	147.26	0.92	23.07	0.0241	-22.66	0.7588	153.25



Typical Package S-Parameters for CGH40025F
(Small Signal, $V_{DS} = 28\text{ V}$, $I_{DQ} = 400\text{ mA}$, angle in degrees)

Frequency	Mag S11	Ang S11	Mag S21	Ang S21	Mag S12	Ang S12	Mag S22	Ang S22
500 MHz	0.9379	-167.54	7.49	90.76	0.0200	5.96	0.7779	-177.18
600 MHz	0.9375	-170.87	6.27	88.10	0.0201	4.35	0.7799	-178.71
700 MHz	0.9373	-173.45	5.38	85.79	0.0202	3.09	0.7810	-179.97
800 MHz	0.9371	-175.57	4.72	83.72	0.0202	2.07	0.7818	178.93
900 MHz	0.9369	-177.38	4.20	81.79	0.0202	1.19	0.7823	177.94
1.0 GHz	0.9368	-178.97	3.79	79.97	0.0203	0.42	0.7826	177.03
1.1 GHz	0.9366	179.60	3.45	78.22	0.0203	-0.27	0.7829	176.17
1.2 GHz	0.9365	178.28	3.17	76.54	0.0203	-0.90	0.7830	175.36
1.3 GHz	0.9364	177.06	2.93	74.89	0.0203	-1.49	0.7831	174.58
1.4 GHz	0.9363	175.90	2.73	73.29	0.0204	-2.04	0.7832	173.81
1.5 GHz	0.9361	174.81	2.55	71.70	0.0204	-2.56	0.7832	173.07
1.6 GHz	0.9360	173.75	2.40	70.14	0.0204	-3.05	0.7832	172.34
1.7 GHz	0.9359	172.73	2.26	68.60	0.0205	-3.53	0.7832	171.62
1.8 GHz	0.9357	171.74	2.14	67.08	0.0205	-3.98	0.7832	170.91
1.9 GHz	0.9356	170.77	2.03	65.56	0.0206	-4.43	0.7831	170.21
2.0 GHz	0.9354	169.82	1.94	64.05	0.0206	-4.86	0.7830	169.50
2.1 GHz	0.9352	168.89	1.85	62.56	0.0207	-5.27	0.7829	168.81
2.2 GHz	0.9351	167.97	1.77	61.06	0.0207	-5.68	0.7828	168.11
2.3 GHz	0.9349	167.05	1.70	59.58	0.0208	-6.08	0.7827	167.41
2.4 GHz	0.9347	166.15	1.63	58.10	0.0208	-6.48	0.7825	166.71
2.5 GHz	0.9345	165.25	1.57	56.62	0.0209	-6.86	0.7824	166.01
2.6 GHz	0.9343	164.35	1.52	55.14	0.0210	-7.24	0.7822	165.31
2.7 GHz	0.9341	163.46	1.47	53.67	0.0210	-7.62	0.7820	164.60
2.8 GHz	0.9339	162.57	1.42	52.20	0.0211	-7.99	0.7818	163.89
2.9 GHz	0.9336	161.68	1.38	50.72	0.0212	-8.35	0.7816	163.18
3.0 GHz	0.9334	160.79	1.34	49.25	0.0213	-8.72	0.7813	162.46
3.1 GHz	0.9331	159.89	1.30	47.78	0.0213	-9.07	0.7811	161.74
3.2 GHz	0.9328	158.99	1.27	46.30	0.0214	-9.43	0.7808	161.01
3.3 GHz	0.9326	158.09	1.23	44.83	0.0215	-9.78	0.7805	160.27
3.4 GHz	0.9323	157.19	1.20	43.35	0.0216	-10.14	0.7801	159.53
3.5 GHz	0.9320	156.28	1.17	41.87	0.0218	-10.49	0.7798	158.78
3.6 GHz	0.9316	155.36	1.15	40.39	0.0219	-10.84	0.7794	158.03
3.7 GHz	0.9313	154.44	1.12	38.90	0.0220	-11.19	0.7790	157.26
3.8 GHz	0.9310	153.50	1.10	37.41	0.0221	-11.54	0.7786	156.49
3.9 GHz	0.9306	152.57	1.08	35.92	0.0222	-11.89	0.7782	155.70
4.0 GHz	0.9302	151.62	1.06	34.43	0.0224	-12.24	0.7777	154.91
4.1 GHz	0.9299	150.66	1.04	32.92	0.0225	-12.59	0.7772	154.11
4.2 GHz	0.9295	149.70	1.02	31.42	0.0227	-12.95	0.7767	153.30
4.3 GHz	0.9291	148.72	1.00	29.91	0.0229	-13.31	0.7762	152.47
4.4 GHz	0.9286	147.73	0.99	28.39	0.0230	-13.67	0.7756	151.64
4.5 GHz	0.9282	146.73	0.97	26.86	0.0232	-14.03	0.7750	150.79



Product Dimensions CGH40025F (Package Type — 440166)

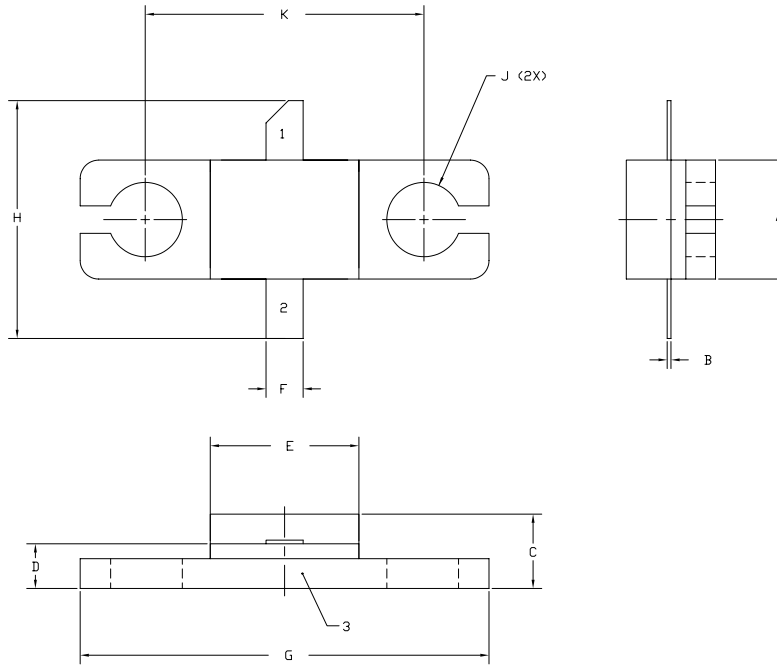

- NOTES:
1. DIMENSIONING AND TOLERANCING PER ANSI Y14.5M, 1982.
 2. CONTROLLING DIMENSION: INCH.
 3. ADHESIVE FROM LID MAY EXTEND A MAXIMUM OF 0.020" BEYOND EDGE OF LID.
 4. LID MAY BE MISALIGNED TO THE BODY OF THE PACKAGE BY A MAXIMUM OF 0.008" IN ANY DIRECTION.
 5. ALL PLATED SURFACES ARE Ni/AU.

DIM	INCHES		MILLIMETERS	
	MIN	MAX	MIN	MAX
A	0.155	0.165	3.94	4.19
B	0.004	0.006	0.10	0.15
C	0.115	0.135	2.92	3.43
D	0.057	0.067	1.45	1.70
E	0.195	0.205	4.95	5.21
F	0.045	0.055	1.14	1.40
G	0.545	0.555	13.84	14.09
H	0.280	0.360	7.87	8.38
J	∅ .100		2.54	
K	0.375		9.53	

PIN 1. GATE
 PIN 2. DRAIN
 PIN 3. SOURCE



Disclaimer

Specifications are subject to change without notice. Cree, Inc. believes the information contained within this data sheet to be accurate and reliable. However, no responsibility is assumed by Cree for any infringement of patents or other rights of third parties which may result from its use. No license is granted by implication or otherwise under any patent or patent rights of Cree. Cree makes no warranty, representation or guarantee regarding the suitability of its products for any particular purpose. "Typical" parameters are the average values expected by Cree in large quantities and are provided for information purposes only. These values can and do vary in different applications and actual performance can vary over time. All operating parameters should be validated by customer's technical experts for each application. Cree products are not designed, intended or authorized for use as components in applications intended for surgical implant into the body or to support or sustain life, in applications in which the failure of the Cree product could result in personal injury or death or in applications for planning, construction, maintenance or direct operation of a nuclear facility.

For more information, please contact:

Cree, Inc.
4600 Silicon Drive
Durham, NC 27703
www.cree.com/wireless

Ryan Baker
Marketing
Cree, Wireless Devices
919.287.7816

Tom Dekker
Sales Director
Cree, Wireless Devices
919.313.5639