

CGH27060F

60 W, 2300-2900 MHz, 28V, GaN HEMT for WiMAX

Cree's CGH27060F is a gallium nitride (GaN) high electron mobility transistor (HEMT) designed specifically for high efficiency, high gain and wide bandwidth capabilities, which makes the CGH27060F ideal for 2.3-2.9GHz WiMAX and BWA amplifier applications. The transistor is supplied in a ceramic/metal flange package.

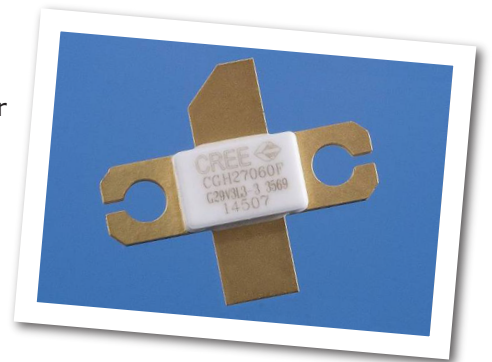

Package Type: 440193
PN: CGH27060F

Typical Performance Over 2.3-2.6GHz ($T_c = 25^\circ\text{C}$) of Demonstration Amplifier

Parameter	2.3 GHz	2.4 GHz	2.5 GHz	2.6 GHz	Units
Small Signal Gain	13.5	13.3	13.0	12.9	dB
EVM @ 39 dBm	2.1	1.9	1.9	2.2	%
Drain Efficiency @ 39 dBm	24.2	23.8	22.5	22.3	%
Input Return Loss	9.8	16.0	7.7	5.9	dB

Note:

Measured in the CGH27060F-TB amplifier circuit, under 802.16-2004 OFDM, 3.5 MHz Channel BW, 1/4 Cyclic Prefix, 64 QAM Modulated Burst, Symbol Length of 59, Coding Type RS-CC, Coding Rate Type 2/3.

Features



- 2.3 - 2.9 GHz Operation
- >13 dB Small Signal Gain
- 2.0 % EVM at 8 W P_{OUT}
- 23 % Efficiency at 8 W P_{OUT}
- 2.7°C/W Typical thermal resistance under 8.0 W P_{AVE} OFDM
- WiMAX Fixed Access 802.16-2004 OFDM
- WiMAX Mobile Access 802.16e OFDMA



Absolute Maximum Ratings (not simultaneous) at 25 °C Case Temperature

Parameter	Symbol	Rating	Units
Drain-Source Voltage	V_{DSS}	84	Volts
Gate-to-Source Voltage	V_{GS}	-10, +2	Volts
Storage Temperature	T_{STG}	-55, +150	°C
Operating Junction Temperature	T_J	175	°C
Soldering Temperature	T_S	245	°C
Thermal Resistance, Junction to Case ¹	$R_{\theta JC}$	2.7	°C/W

Note:

¹ Measured for the CGH27060F at 8 W P_{DISS}

Electrical Characteristics ($T_c = 25^\circ\text{C}$)

Characteristics	Symbol	Min.	Typ.	Max.	Units	Conditions
DC Characteristics⁴						
Gate Threshold Voltage	$V_{GS(th)}$	-3.6	-2.5	-	VDC	$V_{DS} = 10\text{ V}, I_D = 14.4\text{ mA}$
Gate Quiescent Voltage	$V_{GS(Q)}$	-	-2.6	-	VDC	$V_{DS} = 28\text{ V}, I_D = 240\text{ mA}$
Saturated Drain Current	I_{DS}	9.6	10.4	-	A	$V_{DS} = 6.0\text{ V}, V_{GS} = 2\text{ V}$
Drain-Source Breakdown Voltage	V_{BR}	84	100	-	VDC	$V_{GS} = -8\text{ V}, I_D = 14.4\text{ mA}$
Case Operating Temperature	T_c	-10	-	+105	°C	Under 8 W P_{AVE}
Screw Torque	T	-	-	80	in-oz	Reference 440193 Package Revision 1
RF Characteristics^{2,3} ($T_c = 25^\circ\text{C}$, $F_0 = 2.5\text{ GHz}$ unless otherwise noted)						
Small Signal Gain	G_{SS}	-	13.0	-	dB	$V_{DD} = 28\text{ V}, I_{DQ} = 240\text{ mA}$
Drain Efficiency ¹	η	-	22.5	-	%	$V_{DD} = 28\text{ V}, I_{DQ} = 240\text{ mA}, P_{AVE} = 8\text{ W}$
Back-Off Error Vector Magnitude	EVM_1	-	2.5	-	%	$V_{DD} = 28\text{ V}, I_{DQ} = 240\text{ mA}, P_{AVE} = 24\text{ dBm}$
Error Vector Magnitude	EVM_2	-	2.0	-	%	$V_{DD} = 28\text{ V}, I_{DQ} = 240\text{ mA}, P_{AVE} = 8\text{ W}$
Output Mismatch Stress	VSWR	-	TBD	-	Ψ	No damage at all phase angles, $V_{DD} = 28\text{ V}, I_{DQ} = 240\text{ mA}$
Dynamic Characteristics						
Input Capacitance	C_{GS}	-	19.3	-	pF	$V_{DS} = 28\text{ V}, V_{GS} = -8\text{ V}, f = 1\text{ MHz}$
Output Capacitance	C_{DS}	-	4.6	-	pF	$V_{DS} = 28\text{ V}, V_{GS} = -8\text{ V}, f = 1\text{ MHz}$
Feedback Capacitance	C_{GD}	-	1.7	-	pF	$V_{DS} = 28\text{ V}, V_{GS} = -8\text{ V}, f = 1\text{ MHz}$

Notes:

¹ Drain Efficiency = P_{OUT} / P_{DC}

² Under 802.16-2004 OFDM, 3.5 MHz Channel BW, 1/4 Cyclic Prefix, 64 QAM Modulated Burst, Symbol Length of 59, Coding Type RS-CC, Coding Rate Type 2/3.

³ Measured in the CGH27060F-TB test fixture.

⁴ Measured on wafer prior to packaging.

Typical WiMAX Performance

Typical EVM at 24 dBm and 39 dBm vs Frequency of CGH27060F in Broadband Amplifier Circuit CGH27060F-TB

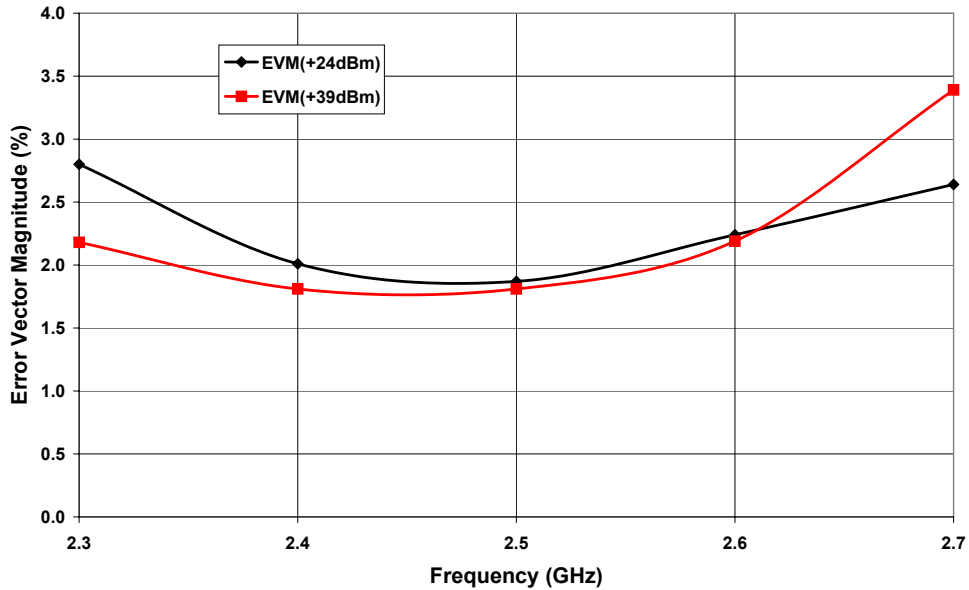

Note:

Under 802.16-2004 OFDM, 3.5 MHz Channel BW, 1/4 Cyclic Prefix, 64 QAM Modulated Burst, Symbol Length of 59, Coding Type RS-CC, Coding Rate Type 2/3.

Gain and Return Loss vs Frequency of CGH27060F in Broadband Amplifier Circuit CGH27060F-TB, $V_{DD} = 28\text{ V}$, $I_{DQ} = 240\text{ mA}$

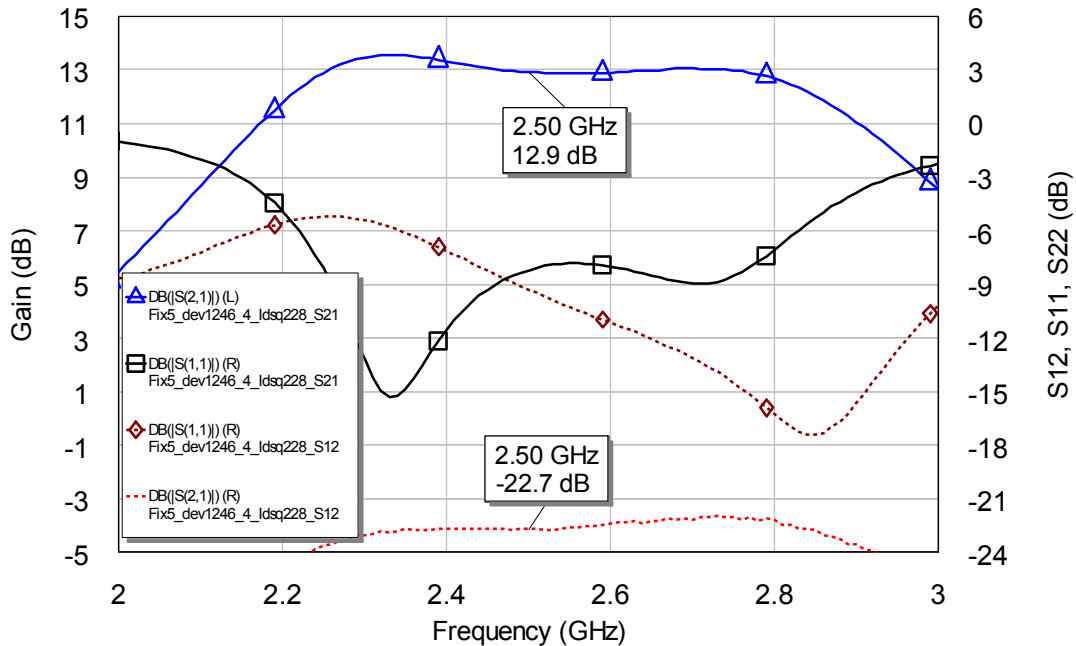



Typical WiMAX Performance

**EVM vs P_{OUT} at 2.5 GHz of CGH27060F in
Broadband Amplifier Circuit CGH27060F-TB**

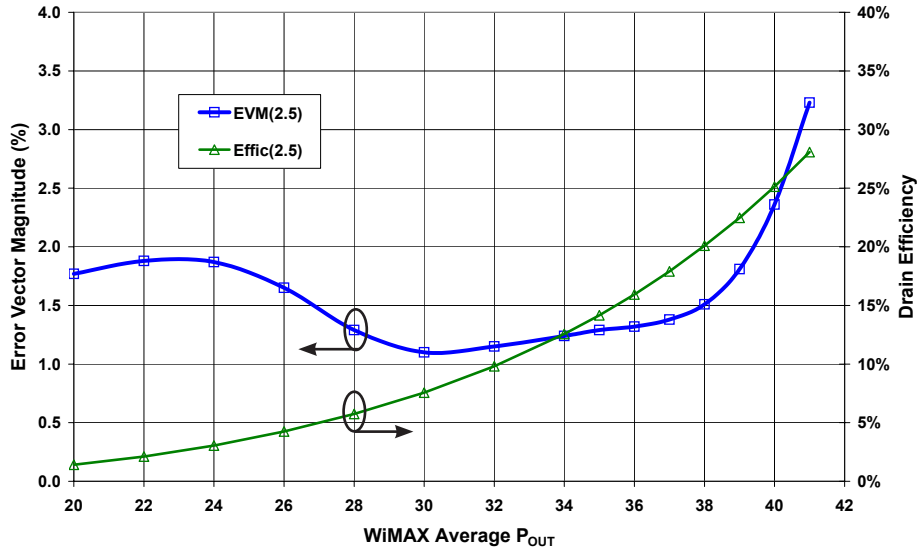

Note:
Under 802.16-2004 OFDM, 3.5 MHz Channel BW, 1/4 Cyclic Prefix, 64 QAM Modulated Burst, Symbol Length of 59, Coding Type RS-CC, Coding Rate Type 2/3.

CGH27060F-TB Demonstration Amplifier Circuit Schematic

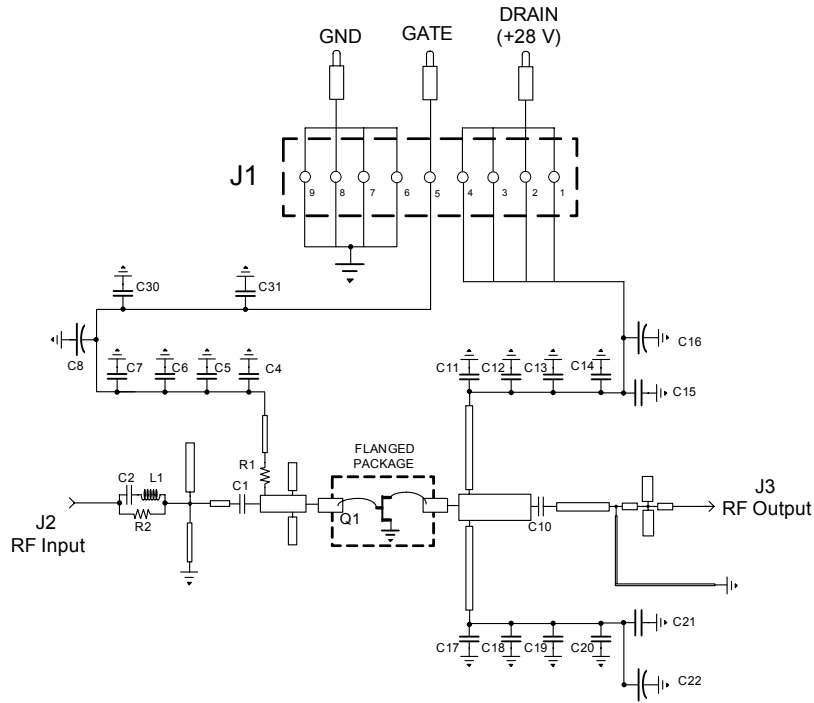

CGH27060F-TB Demonstration Amplifier Circuit Outline

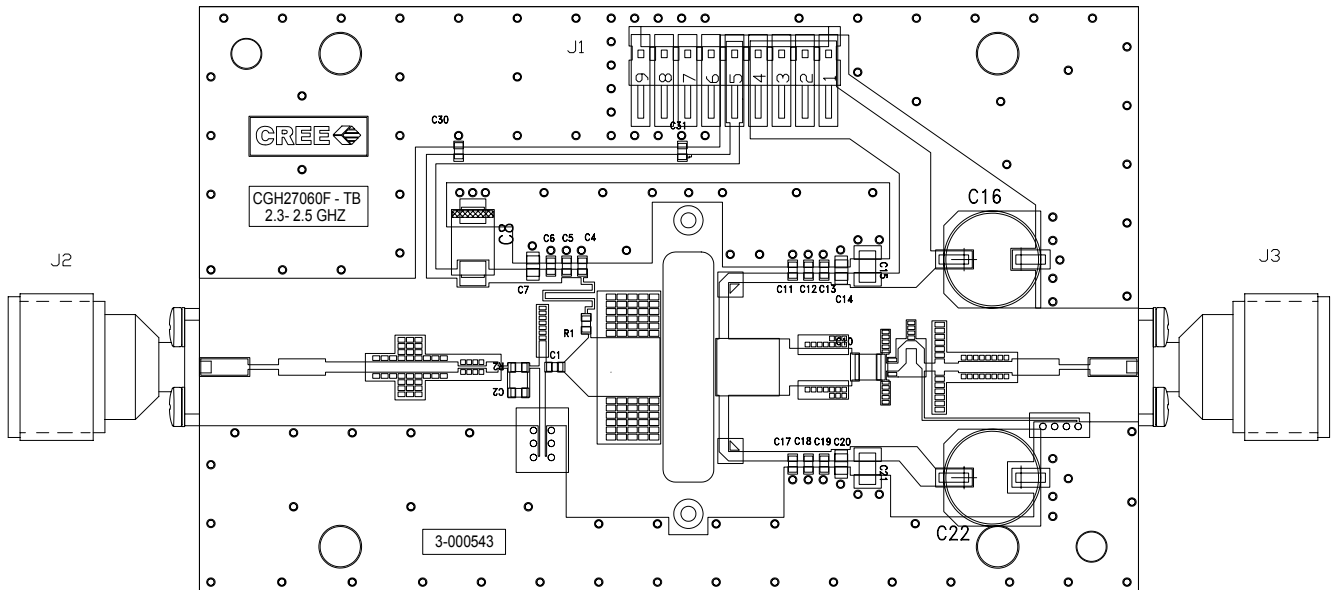

CGH27060F-TB Demonstration Amplifier Circuit Bill of Materials

Designator	Description	Qty
R1	RES, 1/16W, 0603, 1%, 22 OHMS	1
R2	RES, 1/16W, 0603, 1%, 100 OHMS	1
C6,C13,C19	CAP, 470PF, 10%,100V, 0603	3
C16,C22	CAP, 33 UF, 20%, G CASE	1
C15,C21	CAP, 1.0UF, 100V, 10%, X7R, 1210	1
C8	CAP 10UF 16V TANTALUM	1
C10	CAP, 8.2pF, +/-5%, 100B	1
C1	CAP, 0.9pF, +/-0.05pF, 0603	1
C2	CAP, 2.2pF, +/-0.1pF, 0603	1
C4,C11,C17	CAP, 10.0pF,+/-5%, 0603	3
C5,C12,C18,C30,C31	CAP, 82pF, +/-5%, 0603	5
C7,C14,C20	CAP,33000PF, 0805,100V, X7R	3
L1	It is a trace on the PCB and does not require a component.	1
J2,J3	CONN SMA STR PANEL JACK RECP	1
J1	HEADER RT>PLZ .1CEN LK 9POS	1
Q1	CGH27060F	1

CGH27060F-TB Demonstration Amplifier Circuit

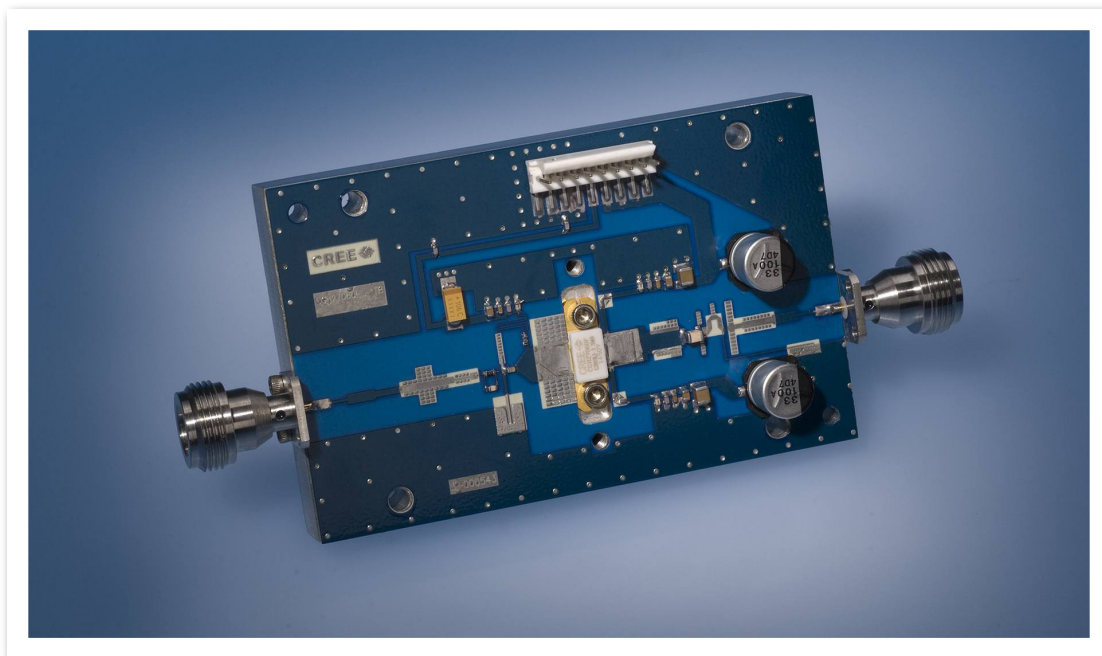

Source and Load Impedances

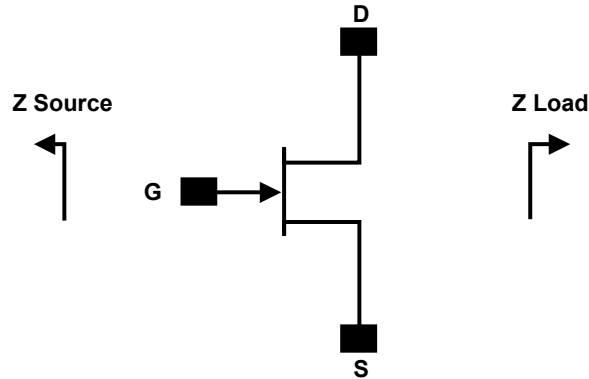

Frequency (MHz)	Z Source	Z Load
2300	3.3 - j7.0	11.2 - j7.8
2400	4.0 - j7.0	9.9 - j8.0
2500	4.1 - j7.5	8.4 - j8.1
2600	3.6 - j7.7	7.3 - j7.8
2700	2.9 - j7.3	6.1 - j7.3

Note¹: $V_{DD} = 28V$, $I_{DQ} = 240mA$. In the 440193 package.

Note²: Impedances are extracted from the CGH27060F-TB demonstration circuit and are not source and load pull data derived from the transistor.

Product Dimensions CGH27060F (Package Type – 440193)

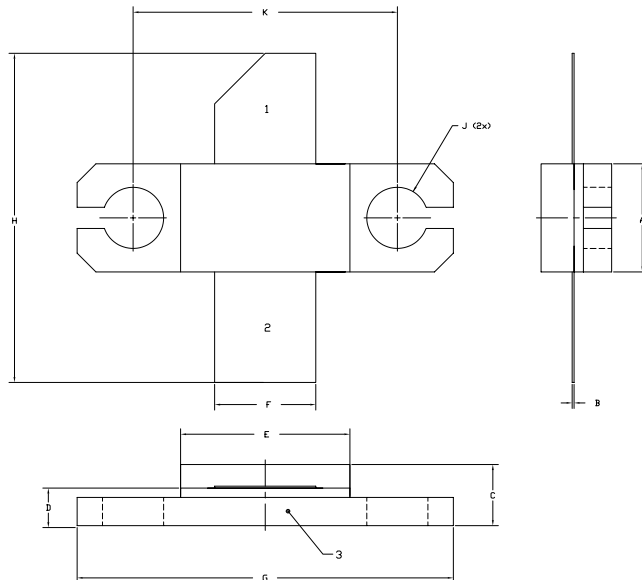

NOTES:

1. DIMENSIONING AND TOLERANCING PER ANSI Y14.5M, 1982.
2. CONTROLLING DIMENSION: INCH.
3. ADHESIVE FROM LID MAY EXTEND A MAXIMUM OF 0.020" BEYOND EDGE OF LID.
4. LID MAY BE MISALIGNED TO THE BODY OF THE PACKAGE BY A MAXIMUM OF 0.008" IN ANY DIRECTION.
5. ALL PLATED SURFACES ARE Ni/AU.

DIM	INCHES		MILLIMETERS	
	MIN	MAX	MIN	MAX
A	0.225	0.235	5.72	5.97
B	0.004	0.006	0.10	0.15
C	0.125	0.135	3.18	3.43
D	0.077	0.087	1.96	2.21
E	0.355	0.365	9.02	9.27
F	0.210	0.220	5.33	5.59
G	0.795	0.805	20.19	20.45
H	0.670	0.730	17.02	18.54
J	ø .130		3.30	
k		0.562		14.28

PIN 1: GATE
 PIN 2: DRAIN
 PIN 3: SOURCE



Disclaimer

Specifications are subject to change without notice. Cree, Inc. believes the information contained within this data sheet to be accurate and reliable. However, no responsibility is assumed by Cree for any infringement of patents or other rights of third parties which may result from its use. No license is granted by implication or otherwise under any patent or patent rights of Cree. Cree makes no warranty, representation or guarantee regarding the suitability of its products for any particular purpose. "Typical" parameters are the average values expected by Cree in large quantities and are provided for information purposes only. These values can and do vary in different applications and actual performance can vary over time. All operating parameters should be validated by customer's technical experts for each application. Cree products are not designed, intended or authorized for use as components in applications intended for surgical implant into the body or to support or sustain life, in applications in which the failure of the Cree product could result in personal injury or death or in applications for planning, construction, maintenance or direct operation of a nuclear facility.

For more information, please contact:

Cree, Inc.
4600 Silicon Drive
Durham, NC 27703
www.cree.com/wireless

Ryan Baker
Marketing
Cree, Wireless Devices
919.287.7816

Tom Dekker
Sales Director
Cree, Wireless Devices
919.313.5639