

PS / 2 Mouse Controller

BU9206

The BU9206 is a PS / 2 mouse communication controller for PCs. This processor shapes waveforms and counts signals from the mouse rotary encoder as the mouse is moved, to provide two-way communication between mouse and PC system.

●Applications

PC mouse

●Features

- 1) For PS / 2 mouse.
- 2) Compatible with a wide range of input signals, because it automatically sets the input threshold levels for the X and Y direction, corresponding to the output level of the rotary encoder inside the mouse.
- 3) CMOS process enables low current consumption.

●Absolute maximum ratings (Ta = 25°C)

Parameter	Symbol	Limits	Unit
Power supply voltage	V _{DD}	- 0.3 ~ + 7.0	V
Power dissipation	P _d	1000*	mW
Operating temperature	T _{opr}	- 25 ~ + 75	°C
Storage temperature	T _{stg}	- 55 ~ + 125	°C
Input voltage	V _{IN}	- 0.3 ~ V _{DD} + 0.3	V
Output voltage	V _{OUT}	- 0.3 ~ V _{DD} + 0.3	V

* Reduced by 10 mW for each increase in Ta of 1°C over 25°C.

●Recommended operating conditions (Ta = 25°C)

Parameter	Symbol	Min.	Typ.	Max.	Unit	Application pin
Power supply voltage	V _{DD}	4.5	5.0	5.5	V	V _{DD}
H input voltage 1	V _{IH1}	0.8*V _{DD}	—	V _{DD}	V	SWR, SWL, TEST2B, TEST1B, TEST0, RESETB
H input voltage 2	V _{IH2}	0.4*V _{DD}	—	V _{DD}	V	SCLK, SDATA
L input voltage 1	V _{IL1}	0	—	0.2*V _{DD}	V	SWR, SWL, TEST2B, TEST1B, TEST0, RESETB
L input voltage 2	V _{IL2}	0	—	0.16*V _{DD}	V	SCLK, SDATA
XY input H voltage	V _{AUP}	0.3*V _{DD}	—	0.8*V _{DD}	V	XA, XB, YA, YB
XY input L voltage	V _{ALP}	0	—	0.48*V _{AUP}	V	XA, XB, YA, YB

●Block diagram

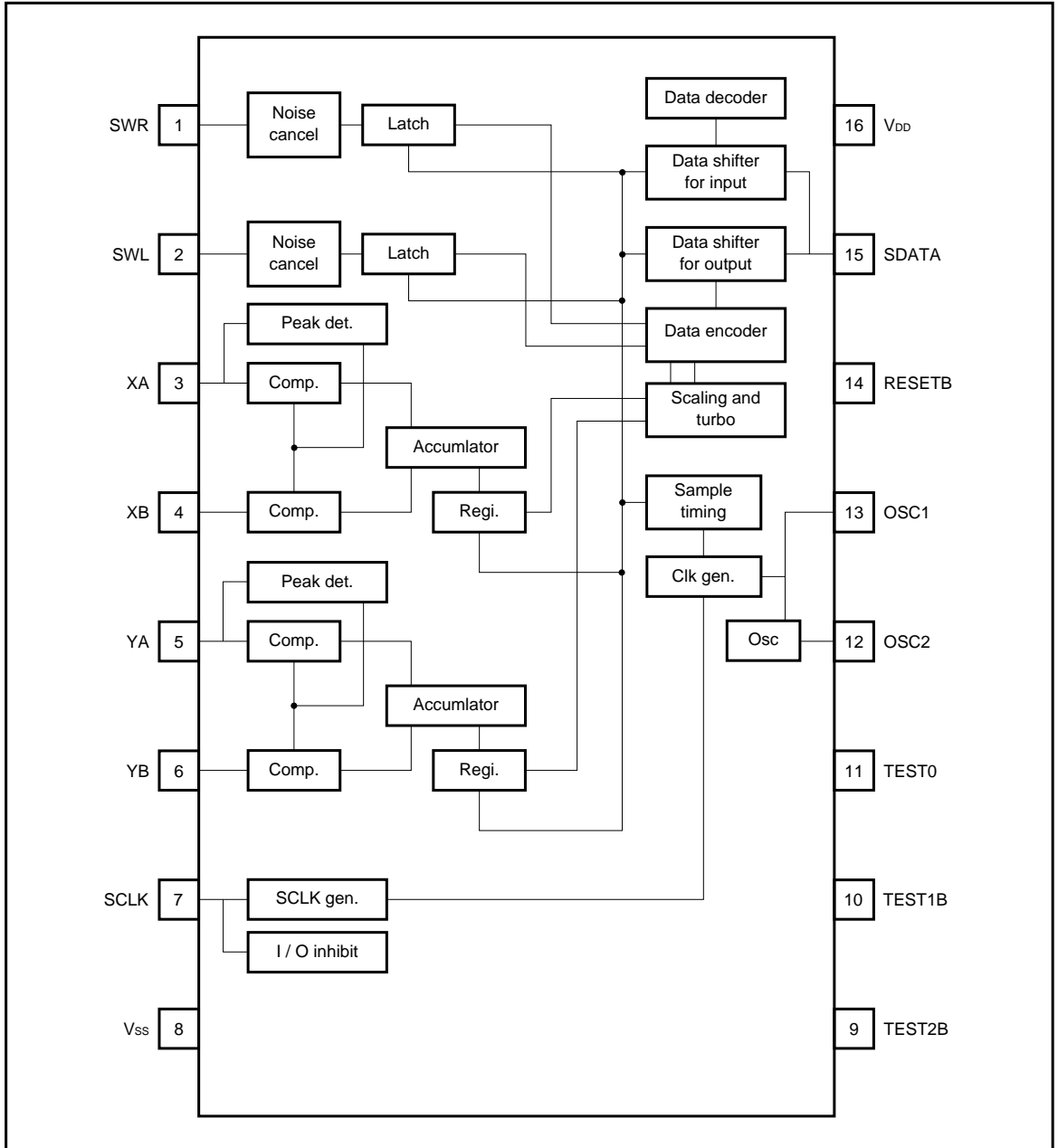

● Pin descriptions

Pin No.	Pin name	I / O	Function	I / O format
1	SWR	IN	Right switch input Pull-up resistor built in Low active	<p>SWR SWL</p> <p>Typ.38kΩ</p>
2	SWL	IN	Left switch input Pull-up resistor built in Low active	
3	XA	IN	Rotary encoder X-direction, A-phase input	<p>XA XB YA YB</p> <p>+</p> <p>COMP</p> <p>-</p> <p>Vref</p>
4	XB	IN	Rotary encoder X-direction, B-phase input	
5	YA	IN	Rotary encoder Y-direction, A-phase input	
6	YB	IN	Rotary encoder Y-direction, B-phase input	
7	SCLK	I / O	Serial clock input / output Pull-up resistor built in Open drain output	<p>Typ.5kΩ</p>
8	V _{SS}	—	Input / output reference voltage: 0V	—
9	TEST2B	IN	Tip test input Pull-up resistor built in Low active	<p>TEST1B TEST2B</p> <p>Typ.11kΩ</p>
10	TEST1B	IN	Normally open or connected to V _{DD}	
11	TEST0	IN	Pull-up resistor built in Normally connected to GND	<p>TURBO</p> <p>Typ.38kΩ</p>

Pin No.	Pin name	I / O	Function	I / O format
12	OSC2	IN	Pin to connect oscillator for clock	
13	OSC1	OUT	Connect a 4MHz oscillator between OSC1 and OSC2.	
14	RESETB	IN	Reset input Pull-up resistor built in Low active	
15	SDATA	I / O	Serial data input / output Pull-up resistor built in Open drain output	
16	V _{DD}	—	Power supply pin Connect a 4.5 - 5.5V power supply.	—

●Electrical characteristics (unless otherwise noted, Ta = 25°C, VDD = 5.0V)

Parameter	Symbol	Min.	Typ.	Max.	Unit	Conditions	Applied pin
Supply current	I _{DD}	0.5	2.1	4.0	mA	f _{CK} = 4.0MHz	V _{DD}
Output low level voltage 1	V _{OL1}	—	0.43	0.6	V	I _{SINK} = 4.0mA	SCLK, SDATA
Input low level current 1	I _{IL1}	98	130	195	μA	V _{IN} = V _{SS}	SWR, SWL, TEST0, RESETB
Input low level current 2	I _{IL2}	330	440	660	μA	V _{IN} = V _{SS}	TEST1B, TEST2B
Input low level current 3	I _{IL3}	0.75	1.0	1.5	mA	V _{IN} = V _{SS}	SCLK, SDATA
Input low level current 4	I _{IL4}	—	—	10	μA	V _{IN} = V _{SS}	XA, XB, YA, YB
Input high level current 1	I _{IH1}	—	—	10	μA	V _{IN} = V _{DD}	SWR, SWL, TEST0, RESETB
Input high level current 2	I _{IH2}	—	—	10	μA	V _{IN} = V _{DD}	TEST1B, TEST2B
Input high level current 3	I _{IH3}	—	—	10	μA	V _{IN} = V _{DD}	SCLK, SDATA
Input high level current 4	I _{IH4}	—	—	10	μA	V _{IN} = V _{DD}	XA, XB, YA, YB
OSC2 input current	I _{OSC}	—	± 6	± 20	μA	V _{IN} = GND or V _{DD}	OSC2
Oscillation frequency	f _{OSC}	—	4.0	—	MHz		OSC1

●Application circuit

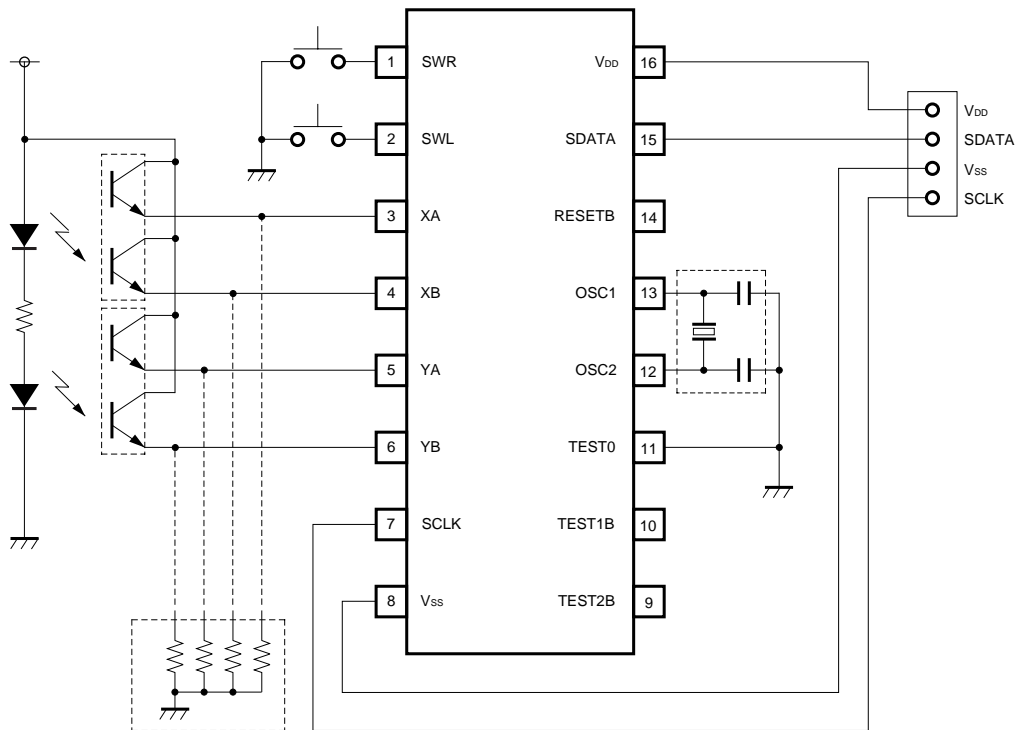

Fig. 1

●External dimensions (Units: mm)

