

# Boca Semiconductor Corp.

## BSC

High Voltage NPN Transistor For General Purpose And Telephony Applications.

### ABSOLUTE MAXIMUM RATINGS(Ta=25deg C unless otherwise specified)

DESCRIPTION	SYMBOL	VALUE	UNIT
Collector -Emitter Voltage	VCEO	160	V
Collector -Base Voltage	VCBO	180	V
Emitter -Base Voltage	VEBO	6.0	V
Collector Current Continuous	IC	600	mA
Power Dissipation @Ta=25 degC	PD	625	mW
Derate Above 25 deg C		5.0	mw/deg C
Power Dissipation @Tc=25 degC	PD	1.5	W
Derate Above 25 deg C		12	mw/deg C
Operating And Storage Junction Temperature Range	Tj, Tstg	-55 to +150	deg C

### THERMAL RESISTANCE

Junction to Case	Rth(j-c)	125	deg C/W
Junction to Ambient	Rth(j-a) (1)	357	deg C/W

(1) Rth (j-a) is measured with the device soldered into a typical printed circuit board

### ELECTRICAL CHARACTERISTICS (Ta=25 deg C Unless Otherwise Specified)

DESCRIPTION	SYMBOL	TEST CONDITION	MIN	TYP	MAX	UNIT
Collector -Emitter Voltage	VCEO	IC=1mA, IB=0	160	-	-	V
Collector -Base Voltage	VCBO	IC=100uA, IE=0	180	-	-	V
Emitter -Base Voltage	VEBO	IE=10uA, IC=-0	6.0	-	-	V
Collector-Cut off Current	ICBO	VCB=160V, IE=0	-	-	50	nA
		Ta=100 deg C				
		VCB=160V, IE=0	-	-	50	uA
Emitter-Cut off Current	IEBO	VEB=4V, IC=0	-	-	50	nA
DC Current Gain	hFE*	IC=1mA, VCE=5V	80	-	-	
		IC=10mA, VCE=5V	80	-	250	
		IC=50mA, VCE=5V	30	-	-	
Collector Emitter Saturation Voltage	VCE(Sat)*	IC=10mA, IB=1mA	-	-	0.15	V
		IC=50mA, IB=5mA	-	-	0.2	V
Base Emitter Saturation Voltage	VBE(Sat) *	IC=10mA, IB=1mA	-	-	1.0	V
		IC=50mA, IB=5mA	-	-	1.0	V

**ELECTRICAL CHARACTERISTICS (Ta=25 deg C Unless Otherwise Specified)**

**2N5551**

DESCRIPTION	SYMBOL	TEST CONDITION	MIN	TYP	MAX	UNIT
<b>Dynamic Characteristics</b>						
Small Signal Current Gain	hfe	IC=1mA, VCE=10V f=1KHz	50	-	200	
Transition Frequency	ft	VCE=10V, IC=10mA, f=100MHz	100	-	300	MHz
Output Capacitance	Cob	VCB=10V, IE=0 f=1MHz	-	-	6.0	pF
Input Capacitance	Cib	VEB=0.5V, IC=0 f=1MHz	-	-	20	pF
Noise Figure	NF	VCE=5V, IC=250uA R=1kohm, f=10Hz to 15.7KHz	-	-	8.0	dB

**\*Pulse Test: Pulse Width=300us, Duty Cycle=2%**

**TO-92 Plastic Package**

**TO-92 Transistors on Tape and Ammo Pack**

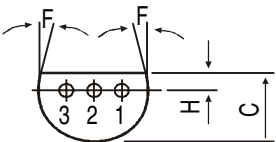
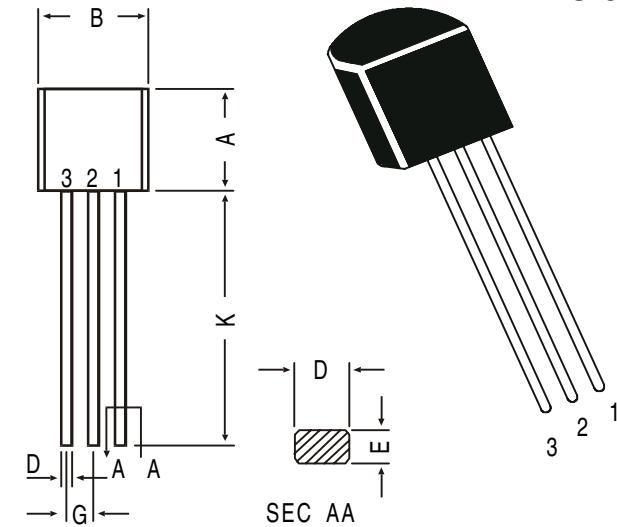

**PIN CONFIGURATION**  
 1. COLLECTOR  
 2. BASE  
 3. EMITTER

All dimensions in mm.

DIM	MIN.	MAX.
A	4.32	5.33
B	4.45	5.20
C	3.18	4.19
D	0.41	0.55
E	0.35	0.50
F	5 DEG	
G	1.14	1.40
H	1.14	1.53
K	12.70	—

**MECHANICAL DATA**

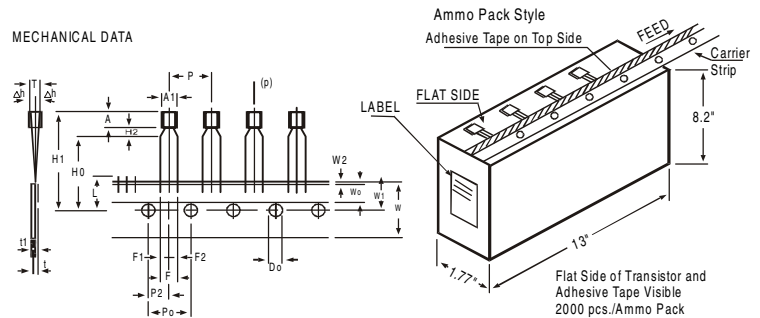

All dimensions in mm unless specified otherwise

ITEM	SYMBOL	SPECIFICATION				REMARKS
		MIN.	NOM.	MAX.	TOL.	
BODY WIDTH	A1	4.0		4.8		
BODY HEIGHT	A	4.8		5.2		
BODY THICKNESS	T	3.9		4.2		
PITCH OF COMPONENT	P		12.7		±1	
FEED HOLE PITCH	Po		12.7		±0.3	CUMULATIVE PITCH ERROR 1.0 mm/20 PITCH
FEED HOLE CENTRE TO COMPONENT CENTRE	P2		6.35		±0.4	TO BE MEASURED AT BOTTOM OF CLINCH
DISTANCE BETWEEN OUTER LEADS	F		5.08		+0.6 -0.2	
COMPONENT ALIGNMENT	Δh		0	1		AT TOP OF BODY
TAPE WIDTH	W		18		±0.5	
HOLD-DOWN TAPE WIDTH	Wo		6		±0.2	
HOLE POSITION	W1		9		+0.7 -0.5	
HOLD-DOWN TAPE POSITION	W2		0.5		±0.2	
LEAD WIRE CLINCH HEIGHT	Ho		16		±0.5	
COMPONENT HEIGHT	H1			23.25		
LENGTH OF SNIPPED LEADS	L			11.0		
FEED HOLE DIAMETER	Do		4		±0.2	
TOTAL TAPE THICKNESS	t			1.2		±0.3 - 0.6
LEAD - TO - LEAD DISTANCE F1,	F2		2.54		+0.4 -0.1	
CLINCH HEIGHT	H2			3		
PULL - OUT FORCE	(P)	6N				

**NOTES**

1. MAXIMUM ALIGNMENT DEVIATION BETWEEN LEADS NOT TO BE GREATER THAN 0.2 mm.
2. MAXIMUM NON-CUMULATIVE VARIATION BETWEEN TAPE FEED HOLES SHALL NOT EXCEED 1 mm IN 20 PITCHES.
3. HOLD-DOWN TAPE NOT TO EXCEED BEYOND THE EDGE(S) OF CARRIER TAPE AND THERE SHALL BE NO EXPOSURE OF ADHESIVE.
4. NO MORE THAN 3 CONSECUTIVE MISSING COMPONENTS ARE PERMITTED.
5. A TAPE TRAILER, HAVING AT LEAST THREE FEED HOLES ARE REQUIRED AFTER THE LAST COMPONENT.
6. ADHESIVE SHALL NOT INTERFERE WITH THE ORDER OF FEED HOLES.