

High-Performance 8051 MCU + 2KB FRAM

Overview

The VRS51L3072 is a high performance, 8051-based microcontroller coupled with a fully integrated array of peripherals for addressing a broad range of embedded design applications.

Based on a powerful 40-MIPS, single-cycle, 8051 microprocessor, the VRS51L3072's memory sub-system features 64KB of Flash and 4352 bytes of SRAM and 2048 Bytes of nonvolatile FRAM (ferroelectric random access memory) memory.

Support peripherals include a hardware based arithmetic unit capable of performing complex mathematical operations, a JTAG interface for Flash programming and non-intrusive in-circuit debugging/emulation, an internal oscillator, and a watchdog timer.

Communication and control of external devices is facilitated via an assortment of digital peripherals such as an enhanced, fully configurable SPI bus, an I²C interface, dual UARTs with dedicated baud rate generators, three 16-bit timers, 8 PWM controllers each with a 16-bit timer, and 2 pulse width counter modules.

The VRS51L3072 operates from 3.0 to 3.6 volts over the industrial temperature range and is available in a QFP-64 package.

Feature Set

- 8051 High Performance Single Cycle Processor (Operation up to 40 MIPS)
- 64KB Flash Program Memory (In-System/In-Application Programmable)
- 4352 Bytes of SRAM (4KB + 256) (Ext. 4KB can be used for program or data memory)
- 2048 Bytes of on-chip FRAM memory
- JTAG Interface for Flash Programming and Non-Intrusive Debugging/In-Circuit Emulation
- MULT/DIV/ACCU Unit including Barrel Shifter
- 56 General Purpose I/Os (64/44-pin version)
- 2 Serial UARTs/2 Baud Rate Generators (20-bit)
- Enhanced SPI Interface (fully configurable word size)
- Fully Configurable I²C Interface (Master/Slave)
- 16 External Interrupt Pins/Interrupt On Port Pin Change
- 16-bit General Purpose Timer/Counters
- 2 Pulse Width Counter Modules
- 8 PWM Controller Outputs with Individual Timers
- PWMs can be used as General Purpose Timers
- Internal Oscillator
- Dynamic System Clock Frequency Adjustment
- Power Saving Features
- Power-On Reset/Brown-Out Detect
- Watchdog Timer
- Operating voltage: 3.0V to 3.6V
- Operating Temperature -40°C to +85°C

FIGURE 1: VRS51L3072 FUNCTIONAL DIAGRAM

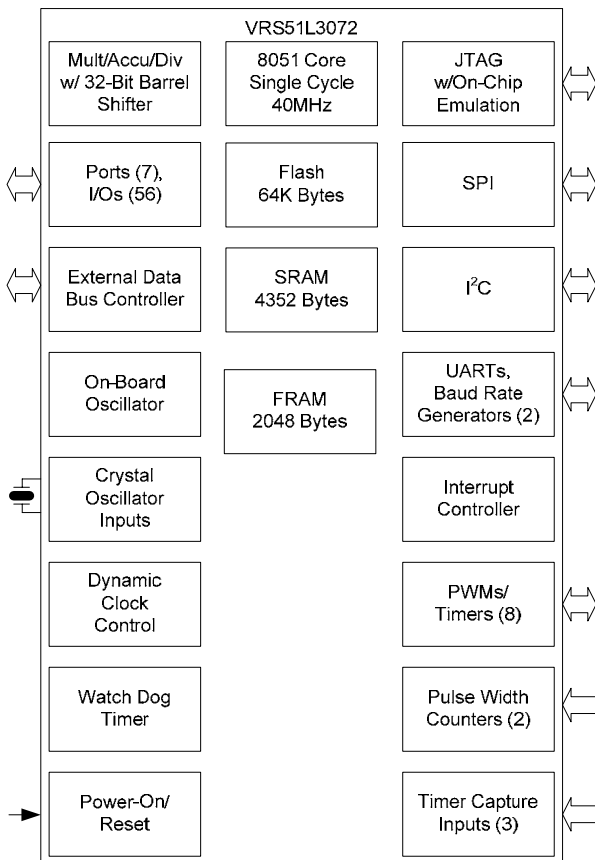

FIGURE 2: VRS51L3072 QFP-64

