

# AZ DISPLAYS, INC.

---

## SPECIFICATIONS FOR LIQUID CRYSTAL DISPLAY

PART NUMBER:

AGM3224M

DATE:

September 8, 2004

# REVISION HISTORY

AGM3224M

	Version	Content	Date
1.	A	Initial Release	9/8/04

## 1. LCD Module Characteristics

No.	Item	Characteristics	Units
(1)	Module Size	103.7 (W) x 76.8 (H) x 6.3 (T)	mm
(2)	Format	320 x (R.G.B.) x 240	Dots
(3)	Active Area	79.7 (W) x 59.7 (H)	mm
(4)	Dot Size	0.068 (W) x 0.234 (H)	mm
(5)	Dot Pitch	0.083 (w) x 0.249 (H)	mm
(6)	Approximate Weight	65	g
(7)	LCD Type	CSTN (Negative/ Transmissive)	
(8)	Drive Method	Duty: 1/244 Bias: 1/16	
(9)	Viewing Direction	6 O'clock	
(10)	Back Light	CCFL (White)	

## 1.2 Mechanical Diagram(Unit:mm)

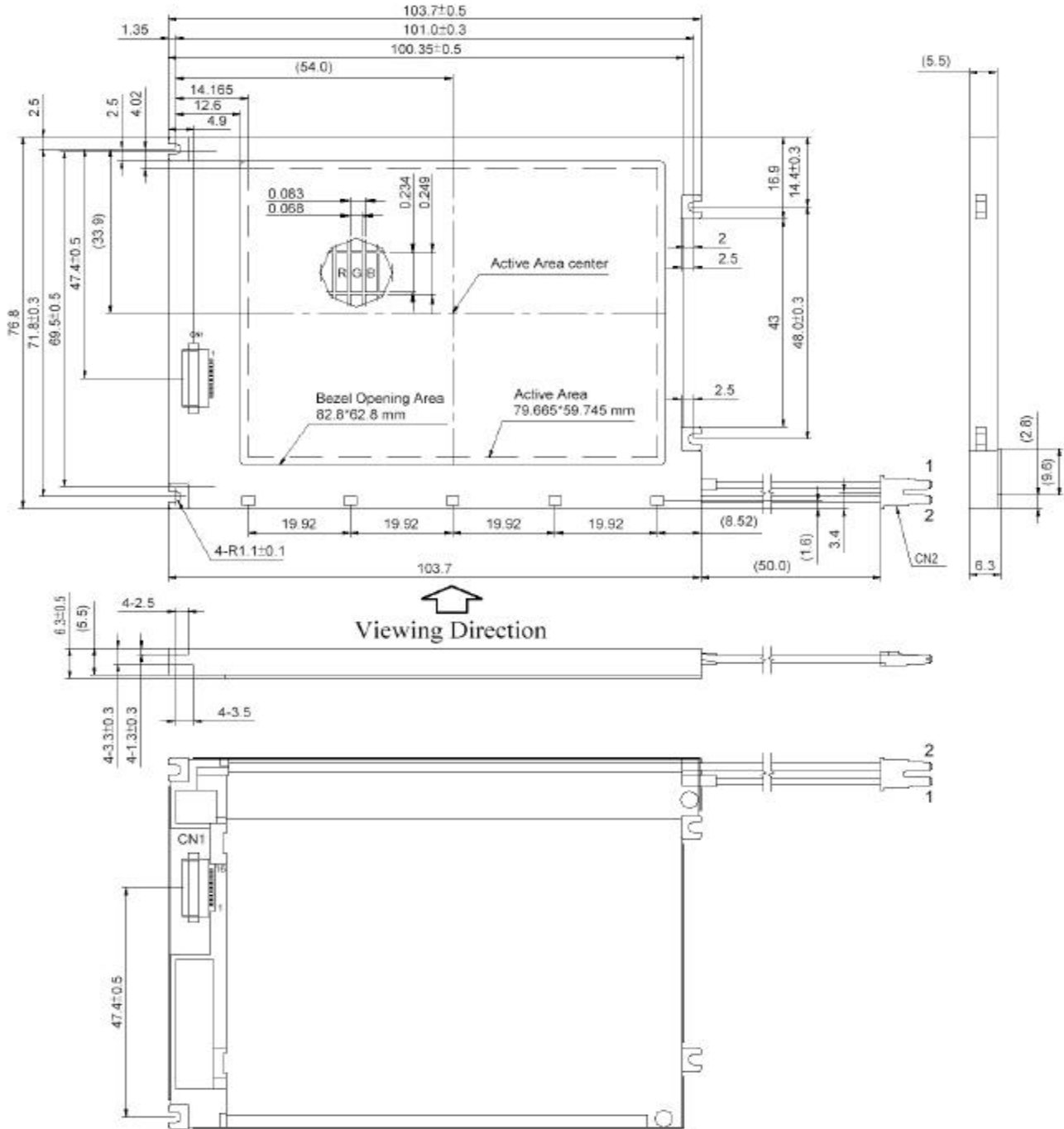

CN1 : 52893-1690(MOLEX)

CN2 : BHSR-02VS-1(JST); (PIN1-HOT, PIN2-GND)

Note 1 : All dimensional tolerance unless otherwise specified±/-.5

## Absolute Maximum Rating

Gnd = 0V, Ta = 25 C

Item	Symbol	Min.	Max.	Unit
Power Supply Logic Voltage	V <sub>DD</sub>	-0.3	+7.0	V
Power Supply for LCD	V <sub>EE</sub> - V <sub>SS</sub>	-0	+30	V
Power Supply Negative Voltage	V <sub>I</sub>	0.3	V <sub>DD</sub> +0.3	V

## Environmental Absolute Maximum Ratings

Item	Storage		Operating		Remarks
	Min,	Max.	Min,	Max.	
Ambient Temperature	-20 C	60 C	0 C	50 C	Note 1,2,3
Humidity	No Condensation				Note 4
Vibration	-				Dependent on application
Shock	-				

Note 1. Ta at -20 C -----< 48 hours, at 60 C -----< 168 hours.

Note 2. Background color changes slightly depending on the ambient temperature.  
The Phenomenon is reversible.

Note 3. When the LCM is operated at 0 C, the life of the CCFL will be reduced.  
The response time of the LCM at 0 C will be lower.

Note 4. Temp at <= 40 C, 85% RH MAX.

Ta > 40C: Absolute humidity must be lower than 85% RH at 40 C.

Note 5. The module should operate normally after the test is completed

## 3.Electrical Characteristics

GND = 0V, Ta = 25?

Item	Symbol	Condition	MIN.	Typ.	Max.	Unit
Power Supply for Logic	V <sub>DD</sub>	—	3.0	3.3	3.6	V
Contrast Adjustment Voltage Note (1)	V <sub>EE</sub>	Duty=1/244	0° C	—	(26.5)	—
		Bias=1/16	25° C	24.5	25.0	25.5
		V <sub>DD</sub> =3.3V	40° C	—	(24.5)	—
Input Signal Voltage Note (2)	V <sub>IH</sub>	"H" Level	0.8V <sub>DD</sub>	—	V <sub>DD</sub>	V
	V <sub>IL</sub>	"L" Level	0	—	0.2V <sub>DD</sub>	
Power supply current Note (3)	I <sub>DD</sub>	V <sub>DD</sub> =3.3V	—	1.0	3.0	mA
	I <sub>EE</sub>	V <sub>EE</sub> =25.0V	—	8.0	9.0	mA
Frame Frequency Note (4)	f <sub>FLM</sub>	—	—	150	—	Hz

Note (1) When an optimum contrast is obtained by naked eyes as the "All Q" test pattern.

Note (2) FLM,M,CL1,CL2,DISP,D0~D7

Note (3) f<sub>FLM</sub>=150Hz,Ta=25°C,Display pattern is Black/White cross pattern as below.

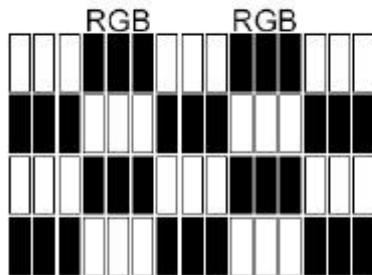

Note (4) Need to make sure that there is no flicker and ripple phenomenon when setting the Frame Frequency in your set.

## 4. Optical Characteristics

Ta= 25°C.(Backlight On)

Item	Symbol	Condition	Min.	Typ.	Max.	Unit	Remark	
Viewing Angle Range	$\phi 1, \phi 2$	CR $\geq 2$	X axle	-	60	-	Deg.	Note 1,2
			Y axle	-	35	-		
Contrast Ratio	CR	$\phi=0^\circ$	-	30	-	-	Note 3,4	
Response Time	Rise	tr	$\theta=0^\circ, \phi=0^\circ$	-	190	-	ms	Note 5
	Fall	tf	$\theta=0^\circ, \phi=0^\circ$	-	110	-		
Color Tone (CIE Coordinate)	R	x	$\theta=0^\circ, \phi=0^\circ$	0.45	0.50	0.55	-	
		y		0.28	0.33	0.38	-	
	G	x		0.23	0.28	0.33	-	
		y		0.45	0.50	0.55	-	
	B	x		0.10	0.15	0.20	-	
		y		0.11	0.16	0.21	-	
	W	x		0.22	0.27	0.32	-	
		y		0.28	0.33	0.38	-	

Note 1. Definition of  $\theta$  and  $\phi$

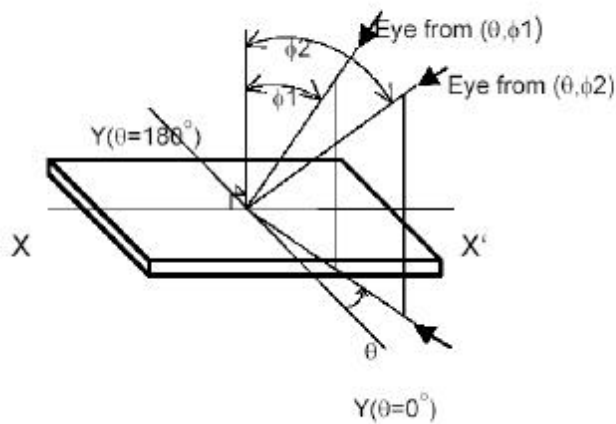

Note 2. Definition of Viewing angle  $\phi 1$  and  $\phi 2$

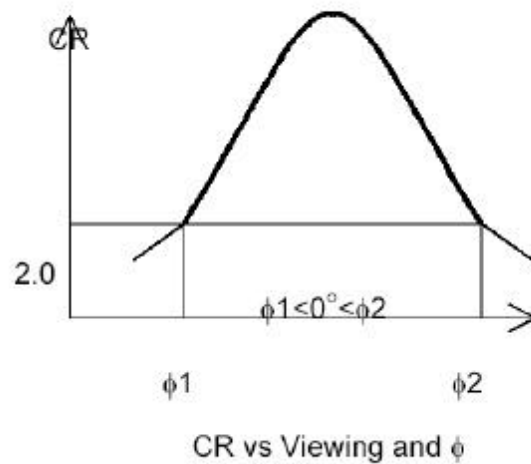

**Note 3. Definition of Contrast Ratio "CR"**

$$CR = \frac{\text{Brightness at selected dot (B1)}}{\text{Brightness at non-selected dot (B2)}}$$

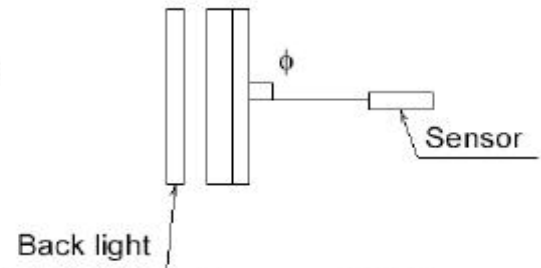
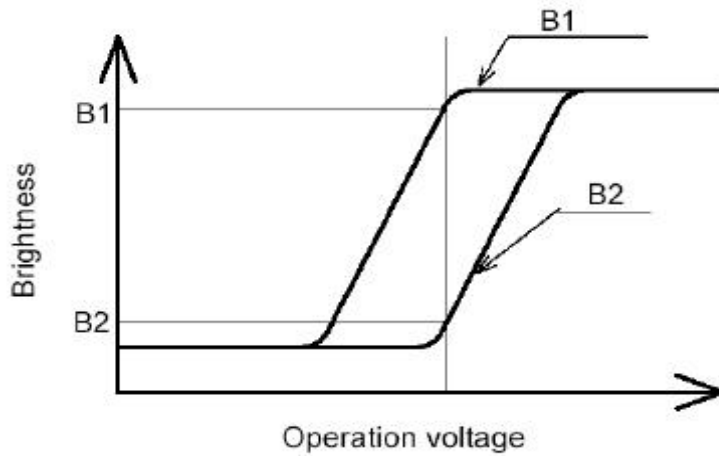

Sensor : BM-7  
Aperture : 1°  
Distance : 50 cm

**Note 4. Definition of "CR" and "V<sub>OP</sub>"**

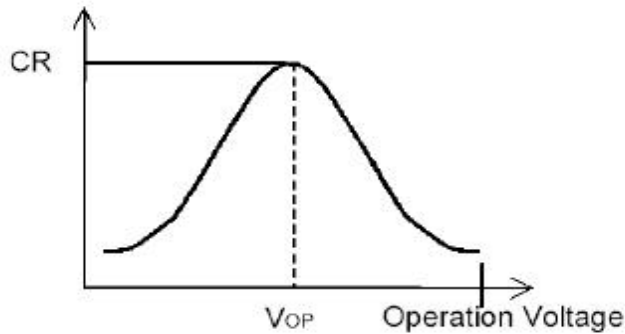

**Note 5. Definition of optical response time**

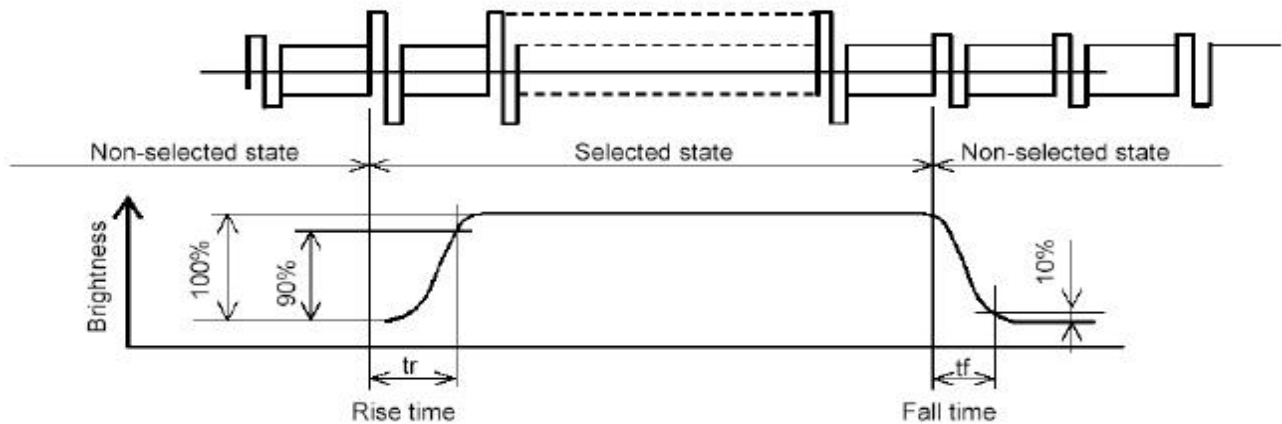



## 5. Interface Pin Function

CN1 : 52893-1690(MOLEX) / Suitable FPC : Pitch 0.5mm, width 8.5mm

Pin No.	Signal	Pin Function
1	D7	Display data
2	D6	Display data
3	D5	Display data
4	D4	Display data
5	D3	Display data
6	D2	Display data
7	D1	Display data
8	D0	Display data
9	V <sub>SS</sub>	GND
10	V <sub>DD</sub>	Logic supply voltage
11	DISP	Display control signal H:ON , L:OFF
12	CL2	Data shift clock
13	CL1	Input data latch signal
14	FLM	Scan start-up signal
15	V <sub>SS</sub>	GND
16	V <sub>EE</sub>	Power supply for LCD

CN2 : BHSR-02VS-1(JST)

Pin No.	Signal	Pin Function
1	H.V	Power supply voltage for CCFL
2	GND	CCFL GND

## 5.1 Interface Timing Chart

### 5.1.1 Timing Chart

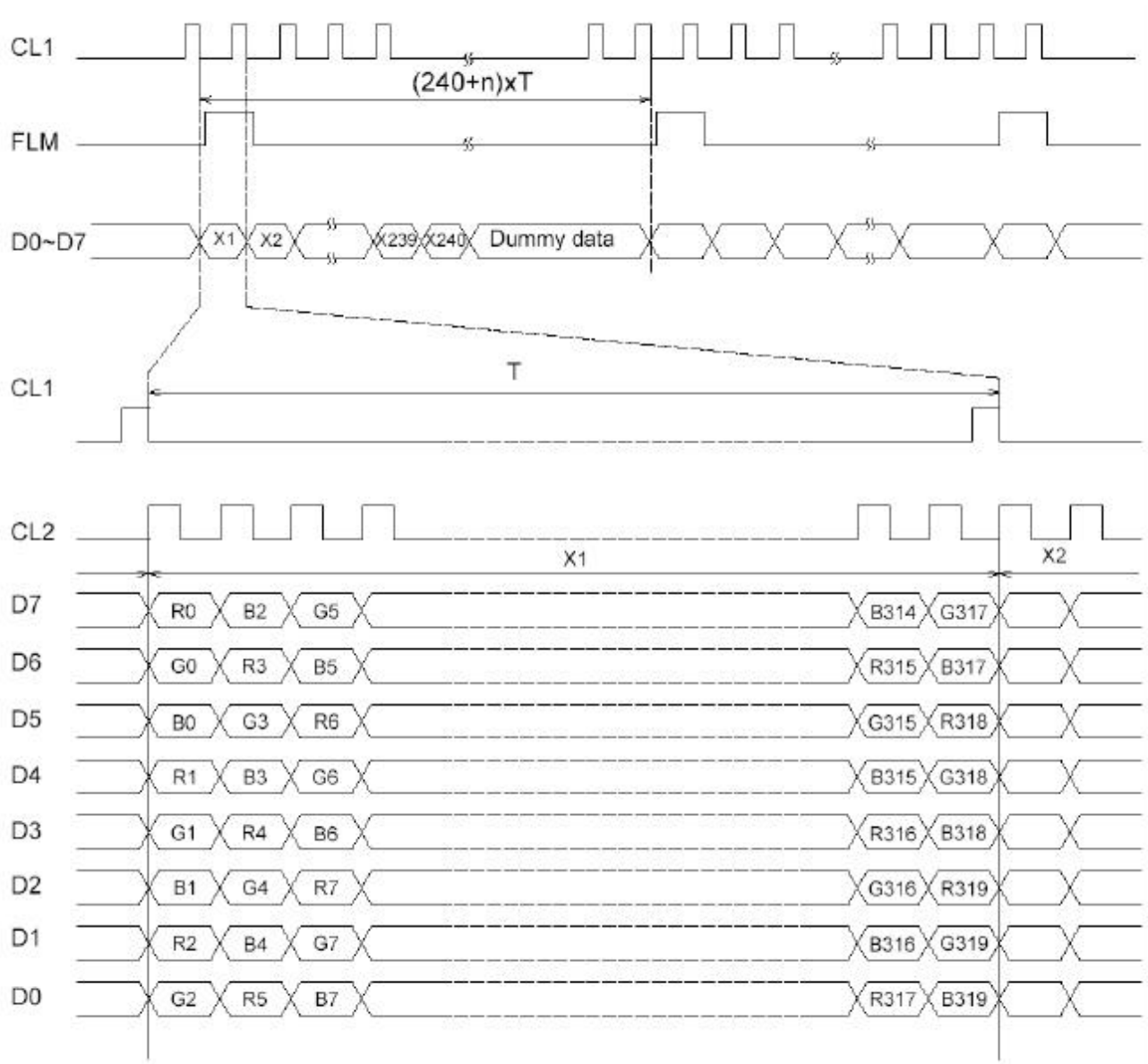

## 5.1.2 AC Characteristics

( $V_{DD}=2.5\sim 3.6V$ ,  $V_{SS}=0V$ ,  $T_a=-20^{\circ}C\sim +85^{\circ}C$ )

Item	Symbol	Min.	Typ.	Max.	Unit
Shift clock period	$t_{WCK}$	33	-	-	ns
Shift clock "H" pulse wide	$t_{WCKH}$	13	-	-	ns
Shift clock "L" pulse wide	$t_{WCKL}$	14	-	-	ns
Data setup time	$t_{DS}$	10	-	-	ns
Data hold time	$t_{DH}$	15	-	-	ns
Latch pulse "H" pulse wide	$t_{WLPH}$	15	-	-	ns
Shift clock rise to latch pulse rise time	$t_{LD}$	5	-	-	ns
Shift clock fall to latch pulse fall time	$t_{SL}$	15	-	-	ns
Latch pulse rise to shift clock rise time	$t_{LS}$	15	-	-	ns
Latch pulse fall to shift clock fall time	$t_{LH}$	15	-	-	ns
Enable setup time	$t_S$	5	-	-	ns
Input signal rise time	$t_R$	-	-	50	ns
Input signal fall time	$t_F$	-	-	50	ns
Out delay time (1)	$t_D$	-	-	25	ns
Out delay time (2)	$t_{PD1}$	-	-	1.2	ns
Out delay time (3)	$t_{PD2}$	-	-	1.2	ns
Out delay time (4)	$t_{PD3}$	-	-	1.2	ns
FLM setup time	$t_{FS}$	100	-	-	ns
FLM hold time	$t_{FH}$	50	-	-	ns

## 5.1.3 Timing Diagrams

### Input Timing Characteristic

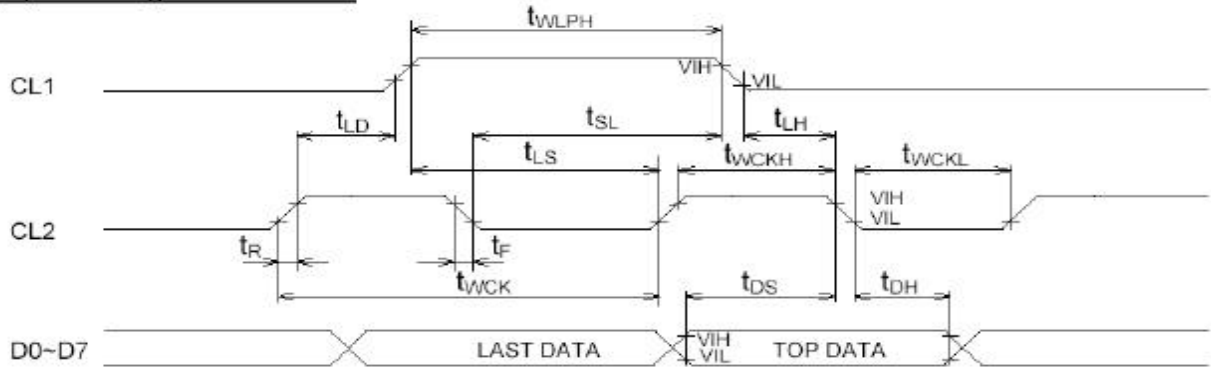

### Input/Output Timing Characteristic

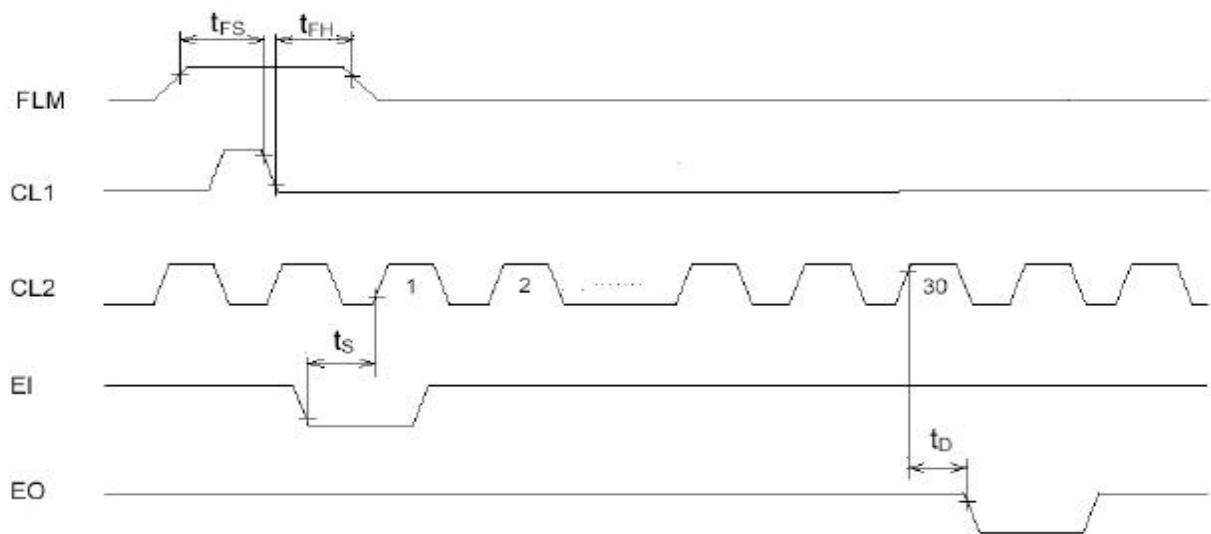

### Input/Output Timing Characteristic

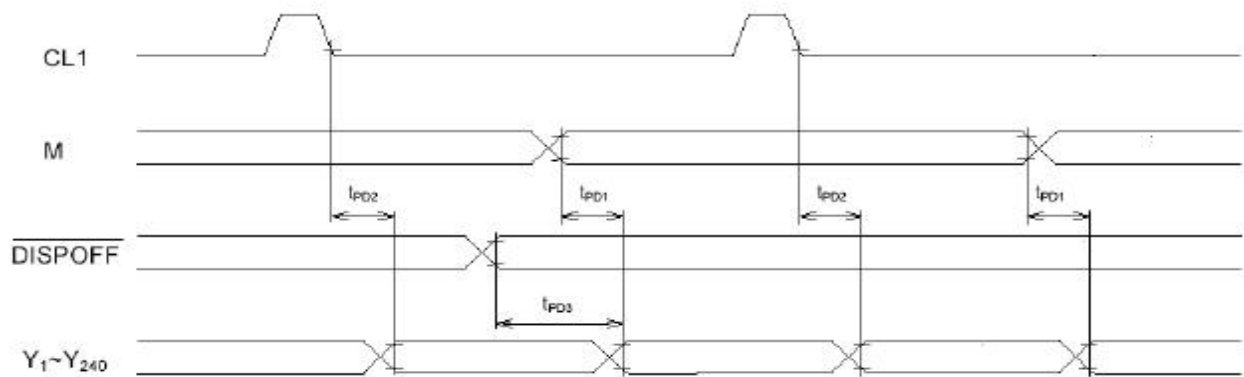

## 5.2 Power ON/OFF Timing

Do not apply DC voltage to the LCD panel because that induces the electrochemical reaction and reduces its life time. Please follow the power supply ON/OFF sequence to prevent DC driving of LCD or latch-up of COMS LSI, as shown below.

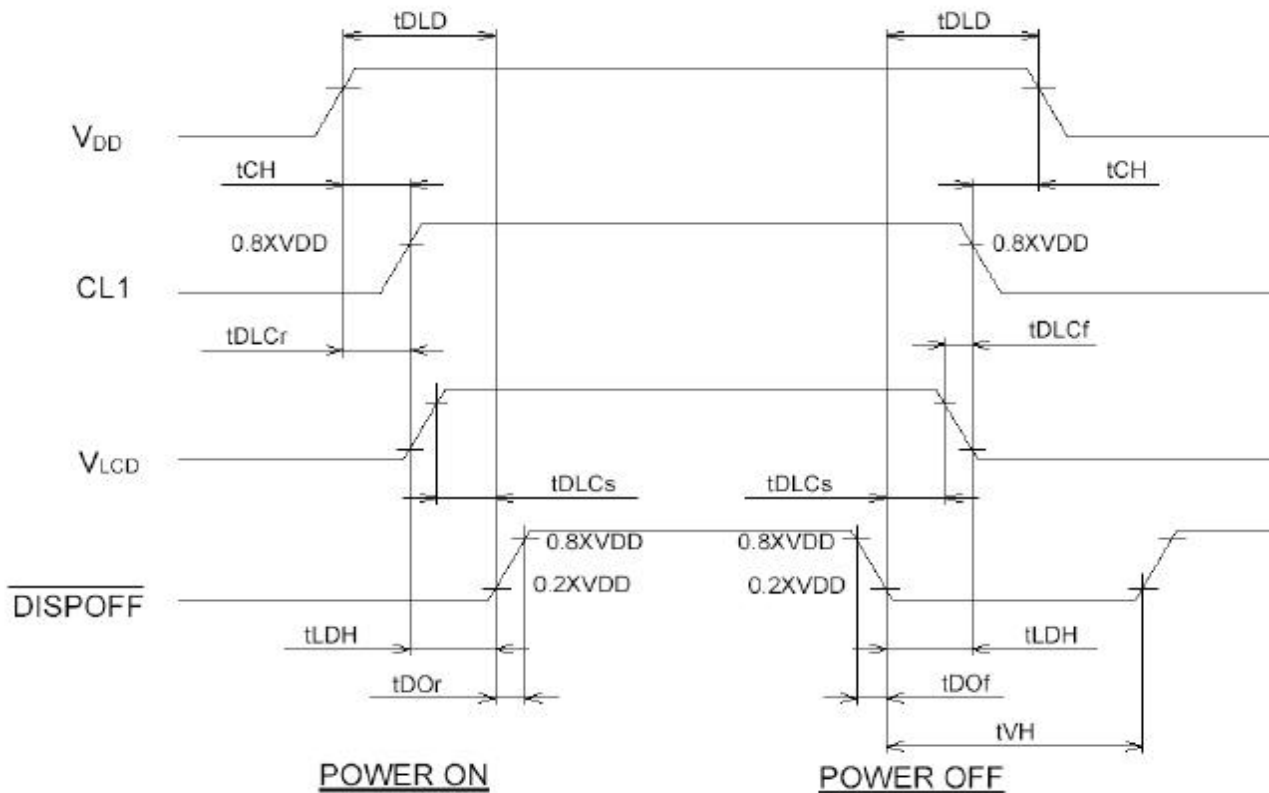

SYMBOL	MIN.	MAX.	UNIT	COMMENT
tDLD	200	-	ms	
tCH	0	-	ms	
tLDH	20	-	ms	
tDOOr	-	100	ns	
tDOF	-	100	ns	
tDLCr	0	-	ms	
tDLCf	0	-	ms	
tDLCs	20	-	ms	
tVH	200	-	ms	

Note 1. Please keep the specified sequence because wrong sequence may cause permanent damage to the LCD panel.

Note 2. We recommends you to use DISPOFF function. Display quality may deteriorate if you don't use DISPOFF function.

## 5.3 Input Data Allocation Table

Data Signal	D 7	D 6	D 5	D 4	D 3	D 2	D 1	D 0	D 7	D 6	D 5	D 4		D 4	D 3	D 2	D 1	D 0
Y X	1	2	3	4	5	6	7	8	9	10	11	12	-----	9 5 6	9 5 7	9 5 8	9 5 9	9 6 0
1	R	G	B	R	G	B	R	G	B	R	G	B		G	B	R	G	B
2	R	G	B	R	G	B	R	G	B	R	G	B		G	B	R	G	B
3	R	G	B	R	G	B	R	G	B	R	G	B		G	B	R	G	B
4	R	G	B	R	G	B	R	G	B	R	G	B		G	B	R	G	B
5	R	G	B	R	G	B	R	G	B	R	G	B		G	B	R	G	B
6	R	G	B	R	G	B	R	G	B	R	G	B		G	B	R	G	B
7	R	G	B	R	G	B	R	G	B	R	G	B		G	B	R	G	B
8	R	G	B	R	G	B	R	G	B	R	G	B		G	B	R	G	B
9	R	G	B	R	G	B	R	G	B	R	G	B		G	B	R	G	B
10	R	G	B	R	G	B	R	G	B	R	G	B		G	B	R	G	B
238	R	G	B	R	G	B	R	G	B	R	G	B		G	B	R	G	B
239	R	G	B	R	G	B	R	G	B	R	G	B		G	B	R	G	B
240	R	G	B	R	G	B	R	G	B	R	G	B		G	B	R	G	B

R : RED  
 G : GREEN  
 B : BLUE

## 6. Block Diagram

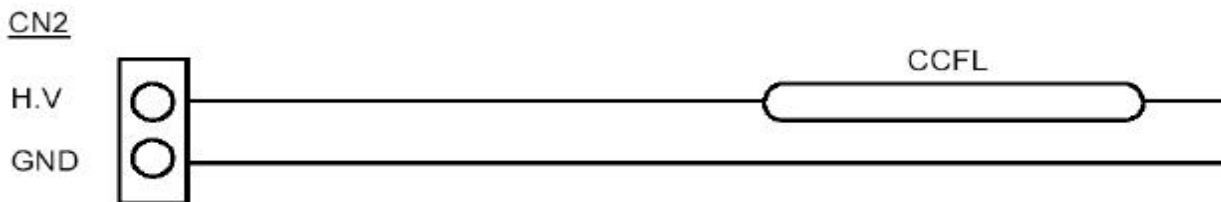
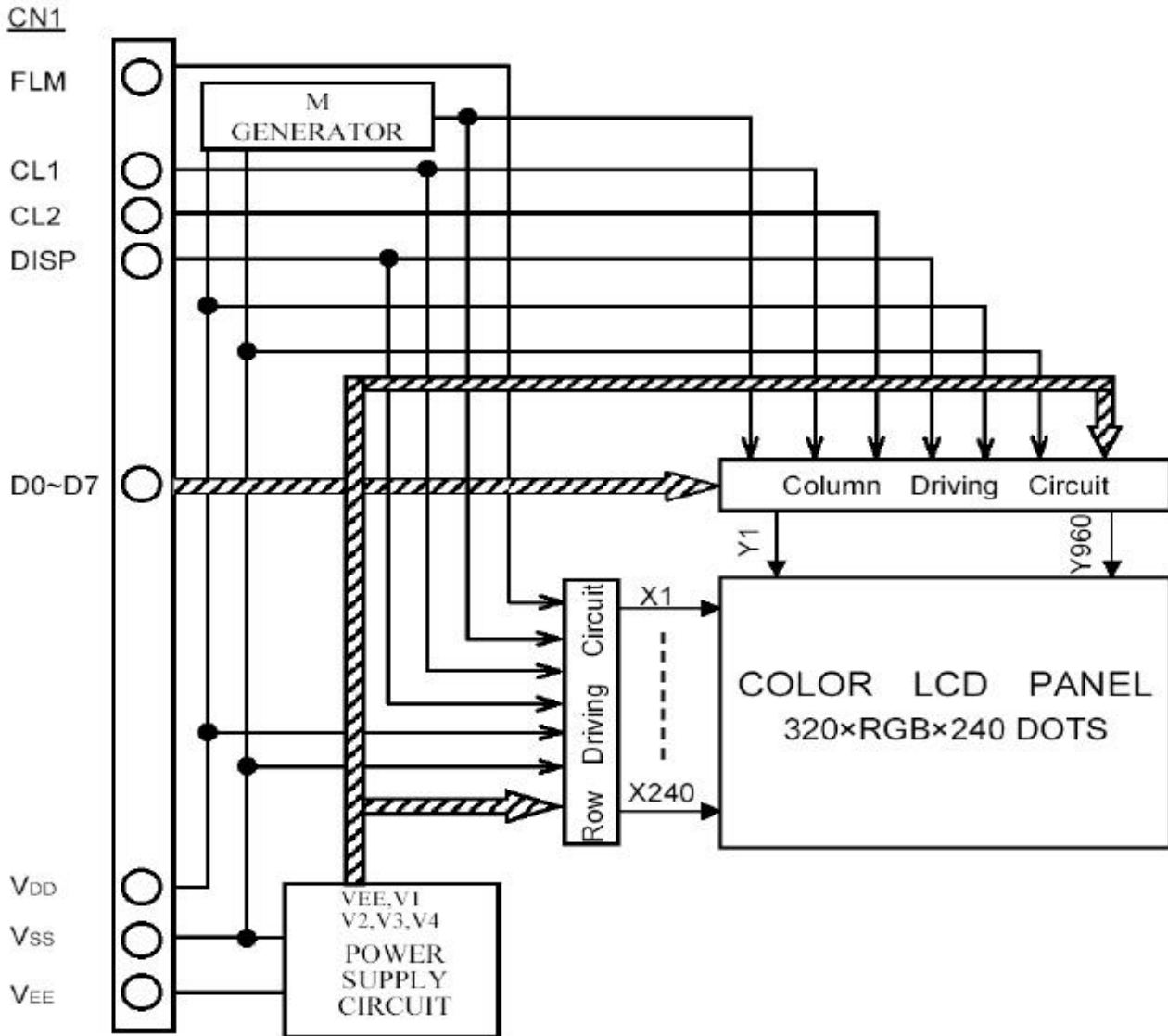

## 7. Backlight Characteristics

Item	Symbol	Min.	Typ.	Max.	Unit	Remark
Starting Voltage	VS	360	-	-	Vrms	Ta=25°C
Lamp Voltage	VL	-	316	-	Vrms	Ta=25°C
Frequency	fL	45	50	55	KHz	Ta=25°C
Lamp Current	IL	2.0	3.0	3.5	mA <sub>rms</sub>	Ta=25°C

Note (1) Starting voltage is higher when LCM at lower temperature.

Note (2) Average life time of CFL will be decreased when LCM is operated at lower temperature

Note (3) CFL life time : 20,000 hours Min. at IL=3.0mA, Ta=25°C



Item	Min.	Typ.	Max.	Unit	Remark
Brightness	-	70	-	cd/m <sup>2</sup>	Note 1,2,3
Brightness Uniformity	-	-	+/-30	%	Note 2,3,4

Note 1. Measurement Condition:

- Display data should be all "ON" (D0~D7=HIGH).
- VDD=3.3V, IL=3.0mA, V<sub>EE</sub> should be adjusted at the voltage where the peak contrast is obtained by naked eyes as the "All Q" pattern.
- Start measuring after CCFL working 10 minutes.

Note 2. Measurement of the following 5 points on the display.

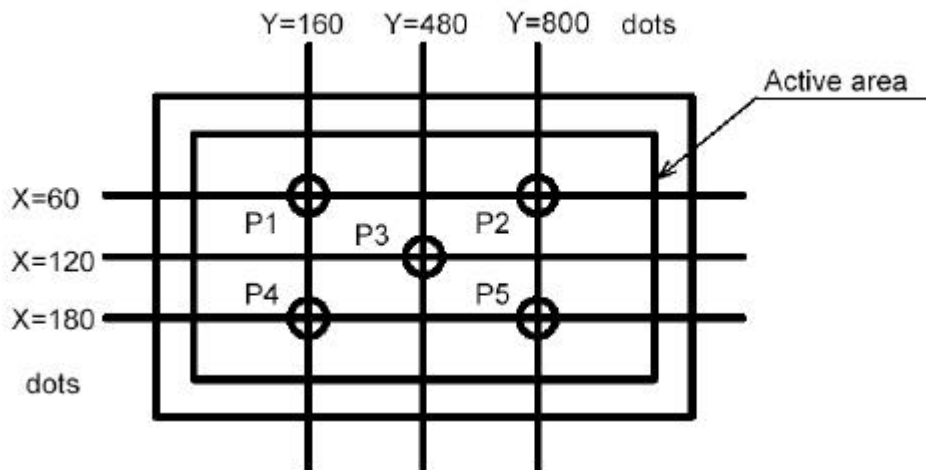

Note 3. The brightness shall be the average of P1~P5 point.

Note 4. Definition of the brightness Uniformity

$$\left( \frac{\text{Max brightness or Min brightness} - \text{Average brightness}}{\text{Average brightness}} \right) \times 100\%$$