

SJ-A2920 Series



Size, mm

9 x 14

I/O

4 J Lead

Supply Voltage

3.3V / 5V

Differential Positive ECL (DPECL) Fast Edge SJ-A2920 Series *Rev K*

Frequency Range: 50.0 MHz to 200.0 MHz

Description

The **SJ-A2920 Series** of quartz crystal oscillators provide DPECL Fast Edge compatible signals. Systems designers may now specify space-saving, cost-effective packaged PECL oscillators to meet their timing requirements.

Features

- High Reliability - NEL HALT/HASS qualified for crystal oscillator start-up conditions
- Low jitter - Wavecrest jitter characterization available
- Wide frequency range—50.0 MHz to 200.0 MHz
- User specified tolerance available
- Will withstand vapor phase temperatures of 253°C for 4 minutes maximum
- Space-saving alternative to discrete component oscillators
- High shock resistance, to 3000g
- 3.3 Volt operation
- Metal lid electrically connected to ground to reduce EMI
- Fast rise and fall times, <600 ps
- Overtone technology
- High Q crystal actively tuned oscillator circuit
- Power supply decoupling internal
- No internal PLL avoids cascading PLL problems
- High frequencies due to proprietary design
- Gold plated leads—Solder dipped leads available upon request
- RoHS Compliant, Lead Free Construction (unless solder dipped leads are supplied)

Creating a Part Number

SJ - A292X - FREQ

Package Code

SJ 4 J Lead 9x14 mm SMD

Input Voltage

Code	Specification
A	3.3 V
	5 V

Tolerance/Performance

0	±100 ppm 0-70°C
1	±50 ppm 0-70°C
7	±25 ppm 0-70°C
9	Customer Specific
A	±20 ppm 0-70°C
B	±50 ppm -40 to +85°C
C	±100 ppm -40 to +85°C

Drawing Specifications

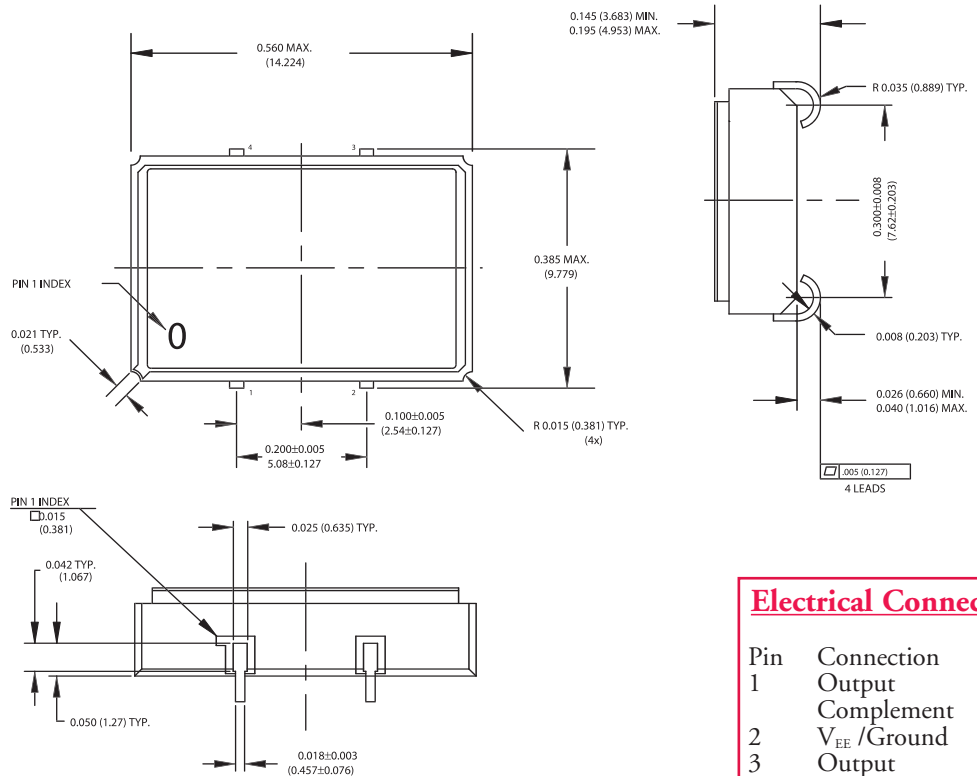

Dimensions shown in inches and millimeters.

Electrical Connection

Pin	Connection
1	Output
2	Complement
3	V _{EE} /Ground
4	V _{CC}



FREQUENCY
CONTROLS, INC.

For the most up to date specifications on each NEL product, log on to our website—www.nelfc.com

Differential Positive ECL (DPECL) Fast Edge

SJ-A2920 Series *Rev K*

Frequency Range: 50.0 MHz to 200.0 MHz

Operating Conditions and Output Characteristics

Electrical Characteristics

Parameter	Symbol	Conditions	Min	Typical	Max
Frequency	—	—	50.0 MHz	—	200.0 MHz
Duty Cycle	—	@V _{CC} -1.29 V	45/55%	—	55/45%
Logic 0 ⁽²⁾	V _{OL}	—	1.35 V	—	1.70 V
Logic 1 ⁽²⁾	V _{OH}	—	2.28 V	—	2.56 V
Rise & Fall Time	t _r , t _f	20-80% V _O with 50 ohm load to V _{CC} -2 V	—	—	600 psec
T _{pd} ⁽⁴⁾	—	—	-200 psec	—	+200 psec
Jitter, RMS ⁽³⁾	—	—	—	—	3 psec
Frequency Stability ⁽¹⁾	dF/F	Overall conditions including: voltage, calibration, temp., 10 yr aging, shock, vibration	-100 ppm	—	+100 ppm

General Characteristics

Parameter	Symbol	Conditions	Min	Typical	Max
Supply Voltage	V _{CC}	—	3.15 V	3.3 V	3.45 V
Supply Current	I _{CC}	50 ohm termination to 2.00 V below V _{CC}	0.0 mA	—	80 mA
Output Current	I _O	Low level Output Current	0.0 mA	—	±50.0 mA
Operating Temperature	T _A	—	0°C	—	70°C
Storage Temperature	T _S	—	-55°C	—	125°C
Power Dissipation	P _D	—	—	—	276 mW
Lead Temperature	T _L	Soldering, 10 sec.	—	—	300°C
Load	—	50 ohm to V _{CC} -2 V or Thevenin Equivalent, Bias Required	—	—	—
Start-up Time	t _S	—	—	2 ms	10 ms

Environmental and Mechanical Characteristics

Mechanical Shock	Per MIL-STD-202, Method 213, Condition E
Thermal Shock	Per MIL-STD-833, Method 1011, Condition A
Vibration	0.060" double amplitude 10 Hz to 55 Hz, 35g's 55 Hz to 2000 Hz
Soldering Condition	300°C for 10 seconds
Hermetic Seal	Leak rate less than 1 x 10 ⁻⁸ atm.cc/sec of helium

Footnotes:

- Standard frequency stability (±20, ±25, ±50 ppm & others available).
- V_{OL}, V_{OH}, referenced to ground (V_{EE}) with V_{CC} = 3.3 V.
- Jitter performance is frequency dependent. Please contact factory for full Wavecrest characterization. RMS jitter bandwidth of 12kHz to 20MHz.
- T_{pd} is phase shift between the falling edge of pin 3 at 2.0 V and the rising edge of pin 1 at 2.01 V.

Test Circuit

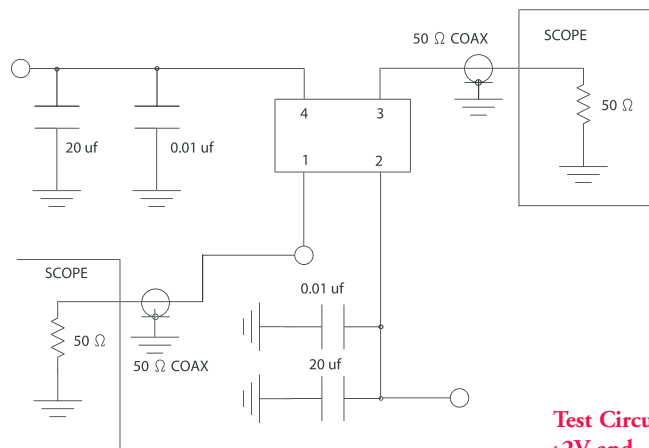

Test Circuit uses a split supply of +2V and -1.3V for ease of testing.