

# RC96V24DP

## Single Device Data/Fax Modem Data Pump

The Rockwell RC96V24DP is a low power, V.22 bis 2400 bps data/fax modem data pump in a single VLSI package. The RC2324DPL is identical to the RC96V24DP except fax modes are not provided. In this document, all references to the RC96V24DP also apply to the RC2324DPL except for the fax modes and as otherwise noted.

The modem operates over the public switched telephone network (PSTN), as well as on point-to-point leased lines.

The modem supports data modes meeting the requirements specified in CCITT recommendations V.22 bis, V.22, V.23, and V.21, as well as Bell 212A and Bell 103.

The modem supports fax modes meeting the requirements specified in CCITT V.29, V.27 ter, and V.21 channel 2 synchronous.

Internal HDLC support eliminates the need for an external serial input/output (SIO) device or comparable functions in the host controller in products incorporating error correction and T.30 protocols.

The modem includes two CMOS VLSI functions – a digital signal processor (DSP) and an integrated analog function (IA). The RC96V24DP integrates these functions into a single 68-pin plastic leaded chip carrier (PLCC).

Detailed hardware and software interface information is described in the Designer's Guide (Order No. 822).

### Functional Block Diagram

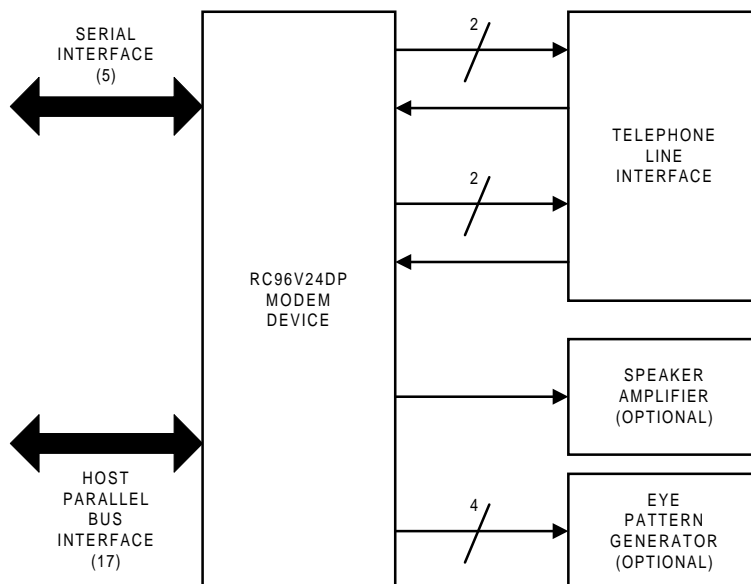

### Product Features

- Single CMOS VLSI device
- Low power requirements
  - Single voltage: + 5 Vdc  $\pm$ 5%
  - Operating: 300 mW (typical)
  - Sleep: 15 mW (typical)
- 2-wire operation
  - Full- duplex (FDX) for data modes
  - Half-duplex (HDX) for fax modes
- Data configurations:
  - V.22 bis, V.22, V.23, V.21
  - Bell 212A, Bell 103
- Fax configurations (RC96V24DP):
  - V.29, V.27 ter, V.21 Channel 2
- Voice mode
- DTMF detection
- Receive dynamic range: -9 dBm to -43 dBm
- Transmit level: -10 dBm  $\pm$ 1 dB using internal hybrid circuit; attenuation selectable in 1 dB steps
- Multi-mode data/fax detection support
- V.22 bis fallback/fall-forward -2400/1200 bps
- Serial data: synchronous and asynchronous
- Parallel data: synchronous (including HDLC) and asynchronous
- Programmable ring detect
- Programmable dialer
- Programmable tone detect bandpass filters
- Adjustable speaker output to monitor received signal
- Diagnostics
- Host bus interface memory for configuration, control, and parallel data; 8086 microprocessor bus compatible
- 5-pin serial data interface; TTL compatible
- Equalization
  - Adaptive equalizer in receiver
  - Selectable and programmable fixed compromise equalizers in both receiver and transmitter
- Loopback configurations
  - Local analog, local digital, and remote digital
- Answer and originate handshake in data modes
- Training sequences for fax modes
- Leased line operation

## Ordering Information

Marketing Number	Manufacturing Number	Package
RC96V24DP	R6653-12	68 pin PLCC
RC96V24DP	R6653-17	100 pin PQFP
RC9624DP	R6653-16	68 pin PLCC
RC9624DP	R6653-21	100 pin PQFP
RC2324DPL	R6653-15	68 pin PLCC
RC2324DPL	R6653-20	100 pin PQFP

### NOTE:

RC2324DPL does not support fax capabilities.

RC9624DP does not support voice.

Copyright © 1998 Rockwell Semiconductor Systems, Inc. All rights reserved.

Print date: September 1998

Rockwell Semiconductor Systems, Inc. reserves the right to make changes to its products or specifications to improve performance, reliability, or manufacturability. Information furnished is believed to be accurate and reliable. However, no responsibility is assumed for its use; nor for any infringement of patents or other rights of third parties which may result from its use. No license is granted by its implication or otherwise under any patent or intellectual property rights of Rockwell Semiconductor Systems, Inc.

Rockwell Semiconductor Systems, Inc. products are not designed or intended for use in life support appliances, devices, or systems where malfunction of a Rockwell Semiconductor Systems, Inc. product can reasonably be expected to result in personal injury or death. Rockwell Semiconductor Systems, Inc. customers using or selling Rockwell Semiconductor Systems, Inc. products for use in such applications do so at their own risk and agree to fully indemnify Rockwell Semiconductor Systems, Inc. for any damages resulting from such improper use or sale.

Specifications are subject to change without notice.

PRINTED IN THE UNITED STATES OF AMERICA

# 1.0 Functional Description

---

## 1.1 Overview

The Rockwell RC96V24DP is a low power, V.22 bis 2400 bps data/fax modem data pump in a single VLSI package.

## 1.2 Technical Specifications

### 1.2.1 Configurations And Rates

The selectable modem configurations, along with the corresponding signaling (baud) rates and data rates, are listed in Table 1-1 (CONF bits).

Note: Bit names refer to control or status bits in DSP interface memory which are set or reset by the host processor (see Table 3-1 and Table 3-2).

### 1.2.2 Data Encoding

The data encoding conforms to CCITT recommendations V.29, V.27 ter, V.22 bis, V.22, V.23, or V.21, or to Bell 212A or 103, depending on the selected configuration.

### 1.2.3 Tone Generation

**Answer Tone:** A CCITT (2100  $\pm$ 15 Hz) or Bell (2225  $\pm$ 10 Hz) answer tone can be generated.

**Guard Tone:** A 1800  $\pm$ 20 Hz guard tone can be generated (enabled by the GTE bit).

**DTMF Tones:** Dual tone multi-frequency (DTMF) tones can be generated with a frequency accuracy of  $\pm$ 1.5%.

**User Defined Tones:** A user-defined single or dual tone can be generated from 200 Hz to 3000 Hz  $\pm$ 5 Hz.

## 1.2.4 Tone Detection

**Answer Tone and Call Progress Tones:** Tones can be detected as follows:

- Call progress frequency range:  $340 \pm 5$  Hz to  $640 \pm 5$  Hz
- Answer tone frequency ranges: CCITT ( $2100 \pm 15$  Hz), Bell ( $2225 \pm 10$  Hz), or Bell FSK originate tone ( $1270 \pm 10$  Hz)
- Detection range: -9 dBm to -43 dBm
- Default detection threshold: -43 dBm
- Response time:  $75 \pm 2$  ms
- The passband and tone detect threshold can be changed in DSP RAM.

**V.23 and V.21 Tones:** Tones can be detected as follows:

- V.23 forward channel mark:  $1300 \pm 10$  Hz
- V.23 backward channel mark:  $390 \pm 10$  Hz
- V.21 high band mark ( $1650 \pm 10$  Hz) or low band mark ( $980 \pm 10$  Hz)
- Detection range: -9 dBm to -43 dBm
- Default detection threshold: -43 dBm
- Response time:  $25 \pm 2$  ms

The passbands and tone detect thresholds can also be changed in the DSP RAM.

### 1.2.4.1 DTMF Detection

The modem can detect a valid DTMF tone pair (indicated by DTDET) and load a corresponding hexadecimal code into the modem interface memory (DTDIG).

### 1.2.4.2 Equalizers

Equalization functions are incorporated that improve performance when operating over low quality lines.

**Automatic Adaptive Equalizer.** An automatic adaptive equalizer in the receiver compensates for transmission line amplitude and group delay distortion. Updating of the taps can be enabled or disabled (EQFZ bit). The equalizer taps can also be reset (EQRES bit).

**Fixed Compromise Equalizers.** Fixed compromise equalizers are provided in the transmitter and receiver. The equalizers are programmable in DSP RAM.

### 1.2.4.3 Transmit Level

The transmitter output level is -10 dBm  $\pm 1$  dB using the internal hybrid circuit. The attenuation is selectable from 0 dBm to -15 dBm in 1 dB steps (TLVL bits).

### 1.2.4.4 Transmit Timing

Transmitter timing is selectable between internal ( $\pm 0.01\%$ ), external, or loopback (TXCLK bits). When external clock is selected, the external clock rate must equal the desired data rate  $\pm 0.01\%$  with a duty cycle of  $50 \pm 20\%$ .

### 1.2.4.5 Scrambler/Descrambler

The modem incorporates a self-synchronizing scrambler/descrambler satisfying the applicable CCITT or Bell requirement. The scrambler and descrambler can be enabled or disabled (SDIS and DDIS bits, respectively).

**1.2.4.6 Receive Level** The receiver satisfies performance requirements for a received line signal from -9 dBm to -43 dBm. The default RLSD turn-on and RLSD turn-off thresholds are -43 dBm and -48 dBm, respectively. The RLSD threshold levels are programmable in DSP RAM.

**1.2.4.7 Receiver Timing** The modem can track a frequency error up to  $\pm 0.03\%$  in the associated transmit timing source.

**1.2.4.8 Carrier Recovery** The modem can track a frequency offset up to  $\pm 7$  Hz in the received carrier with less than a 0.2 dB degradation in bit error rate (BER).

Table 1-1. Configurations, Signaling and Data Rates

Configuration	Modulation	Transmitter Carrier Frequency (Hz) $\pm 0.01\%$		Data Rate (bps)	Baud (Symbols/Sec)	Bits Per Symbol	Constellation Points	Sample Rate (Samples/Sec)
		Answer <sup>2</sup>	Originate <sup>2</sup>	$\pm 0.01\%$				
<b>Data Modes</b>								
V.22 bis	QAM	2400	1200	2400 <sup>3</sup>	600	4	16	7200
V.22	DPSK	2400	1200	1200 <sup>3</sup>	600	2	4	7200
		2400	1200	600 <sup>3</sup>	600	1	2	7200
Bell 212A	DPSK	2400	1200	1200 <sup>3</sup>	600	2	4	7200
Bell 103	FSK	2225 M 2025 S	1270 M 1070 S	0-300 <sup>4</sup>	0-300 <sup>4</sup>	1	1	7200
V.21	FSK	1650 M 1850 S	980 M 1180 S	0-300 <sup>4</sup>	0-300 <sup>4</sup>	1	1	7500
V.23 Forward Channel <sup>5</sup>	FSK	1300 M 2100 S	1300 M 2100 S	1200	1200	1	1	9600 <sup>5</sup>
V.23 Backward Channel <sup>5</sup>	FSK	390 M 450 S	390 M 450 S	75	75	1	1	7200
<b>Fax Modes<sup>6</sup></b>								
V.29	QAM	1700	1700	9600	2400	4	16	9600
	QAM	1700	1700	7200	2400	3	8	7200
	QAM	1700	1700	4800	2400	2	4	9600
V.27 ter	DPSK	1800	1800	4800	1600	3	8	9600
	DPSK	1800	1800	2400	1200	2	4	9600
V.21 channel 2	FSK	1650 M 1850 S	1650 M 1850 S	300	300	1	1	9600
Dial/Call Progress Mode					600			7200
Tone Generator/ Tone Detector Mode					600			7200
Notes: (1) Modulation legend:    QAM    Quadrature Amplitude Modulation DPSK    Differential Phase Shift Keying FSK    Frequency Shift Keying (2) M indicates a mark condition; S indicates a space condition. (3) Synchronous accuracy = $\pm 0.01\%$ ; asynchronous accuracy = -2.5% to +1.0% (+2.3% if extended overspeed is selected). (4) Value is upper limit for serial (e.g. 0-300). (5) RC2324DPL only. (6) RC96V24DP only. (7) 9600 samples per sec in V.23 FDX Tx75/Rx1200; 7200 samples per second in V.23 FDX Tx1200/Rx75.								

**Table 1-2. Dial Digits/Tone Pairs**

Dial Digit	Tone 1 (Hz)	Tone 2 (Hz)
1	697	1209
2	697	1336
3	697	1447
4	770	1209
5	770	1336
6	770	1447
7	852	1209
8	852	1336
9	852	1477
0	941	1336
*	941	1209
#	941	1477
Spare B	967	1633

#### 1.2.4.9 RTS-CTS Turn-On and Turn-Off Sequences

RTS ON to CTS ON and RTS OFF to CTS OFF response times are listed in Table 1-3.

In V.21, the transmitter turns off within 10 ms after RTS goes OFF.

For V.29, the turn-off sequence consists of approximately 5 ms of remaining data and scrambled ones followed by a 50 ms period of no transmitted energy.

For V.27 ter, the turn-off sequence consists of approximately 7 ms of remaining data and scrambled ones at 1200 baud or approximately 7.5 ms of data and scrambled ones at 1600 baud followed by a 20 ms period of no transmitted energy.

## 1.2.5 Serial or Parallel Interface

The TPDM bit selects serial or parallel interface.

**Serial Interface.** The five hardware lines (RXD, TXD, TDCLK,  $\overline{\text{RDCLK}}$ , and XTCLK) are supported by four control and status bits in the interface memory (CTS, DSR, RTS, and RLSD).

**Parallel Interface.** A 8086-compatible parallel microprocessor bus is supported.

## 1.2.6 Voice Mode

**Transmit Voice.** Transmit voice samples can be sent to the modem digital-to-analog converter (DAC) from the host through the transmit data buffer.

**Receive Voice.** Received voice samples from the modem analog-to-digital converter (ADC) can be read by the host from the receive data buffer.

## 1.2.7 Asynchronous Conversion

Asynchronous mode is selected by the ASYNC bit. The asynchronous character format is 1 start bit, 5 to 8 data bits (WDSZ bits), an optional parity bit (PARSL and PEN bits), and 1 or 2 stop bits (STB bit). Valid character size, including all bits, is 7, 8, 9, 10 or 11 bits per character.

**Table 1-3. RTS-CTS Response Times**

Configuration	Turn On Time	Turn Off Time
<b>Data Modes</b>		
V.22 bis, V.22, and Bell 212A (CC bit = 0)	≤ 2 ms	≤ 2 ms
V.22 bis, V.22, and Bell 212A (CC bit = 1)	270 ms	≤ 2 ms
V.21 and Bell 103	2-5 ms	10 ms
V.23 (RC96V24DP and RC2324DPL only)	11 ms	≤ 2 ms
<b>Fax Modes (RC96V24DP only)</b>		
<b>Echo Protector Tone Disabled (NV25 = 1)</b>		
V.29 (All speeds)	253 ms	≤ 2 ms
V.27 4800	898 ms	≤ 2 ms
V.27 2400	1133 ms	9 ms
V.21	20 ms	4 ms
<b>Echo Protector Tone Enabled (NV25 = 0)</b>		
V.29 (All speeds)	253 ms	≤ 2 ms
V.27 4800	1103 ms	≤ 2 ms
V.27 2400	1338 ms	9 ms
V.21	3095 ms	4 ms

**Signalling Rate Range.** Signalling rate range is selectable by the EXOS bit:

- Basic range: +1% to -2.5%
- Extended overspeed range: +2.3% to -2.5%

**Break.** Break is handled as described in V.22 bis.



### 1.2.7.1 Power and Environmental Requirements

The power requirements are specified in Table 1-4. The environmental specifications are listed in Table 1-5.

**Table 1-4. Modem Power Requirements**

Voltage	Mode	Current (Typ) @ 25°C	Current (Max) @ 0°C
5VDC $\pm$ 5%	Operating	60 mA	90 mA
	Sleep	3 mA	4.5 mA
Note: Input voltage ripple $\leq$ 0.1 volts peak-to-peak. The amplitude of any frequency between 20 kHz and 150 kHz must be less than 500 microvolts peak.			

**Table 1-5. Modem Environmental Specifications**

Parameter	Specification
Temperature	
Operating	0° C to 70° C (32° F to 158° F)
Storage	-40° C to 80° C (-40° F to 176° F)
Relative Humidity	Up to 90% noncondensing, or a wet bulb temperature up to 35° C, whichever is less.
Altitude	-200 feet to +10,000 feet



## 2.0 Hardware Interface

---

The modem functional hardware interface signals are shown in Figure 2-1. In this diagram, any point that is active low is represented by a small circle at the signal point.

Edge triggered inputs are denoted by a small triangle (e.g., TDCLK). Open-Collector (open-source or open-drain) outputs are denoted by a small half-circle (e.g.,  $\overline{\text{IRQ}}$ ). Active low signals are overscored (e.g.,  $\overline{\text{POR}}$ ).

A dock intended to activate logic on its rising edge (low-to-high transition) is called active low (e.g.,  $\overline{\text{RDCLK}}$ ), while a clock intended to activate logic on its falling edge (high-to-low transition) is called active high (e.g., TDCLK). When a clock input is associated with a small circle, the input activates on a falling edge. If no circle is shown, the input activates on a rising edge.

The modem pin assignments are shown in Figure 2-2. The pin assignments are listed by pin number in Table 2-1.

The hardware interface signal functions are summarized by major interface in Table 2-2.

The digital and analog interface characteristics are defined in Table 2-3 and Table 2-4, respectively.

Figure 2-1. RC9623DP Functional Interface Signals

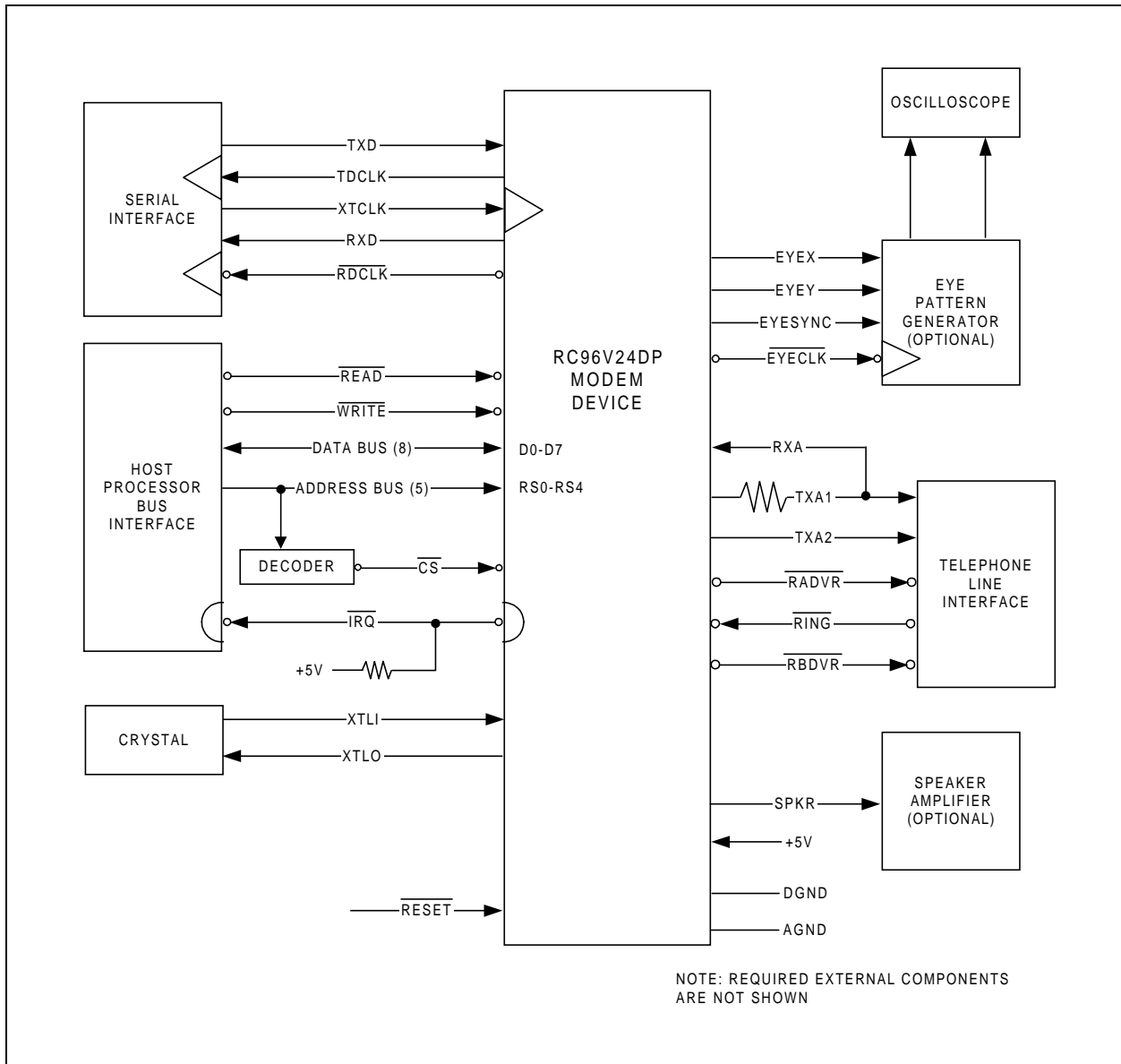

Figure 2-2. RC9623DP Pin Signals

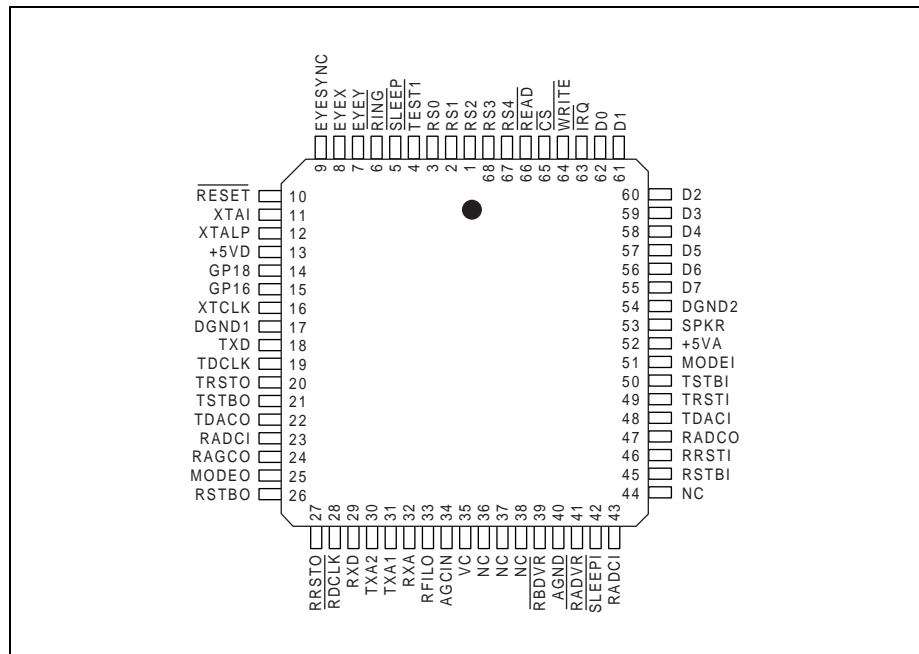

Table 2-1. RC9623DP Modem Device Pin Signals

Pin Number	Signal Name	I/O Type
1	RS2	IA
2	RS1	IA
3	RS0	IA
4	TEST1	
5	SLEEP	OA
6	RING	
7	EYEX	OB
8	EYEX	OB
9	EYESYNC	OB
10	RESET	ID
11	XTLI	IE
12	XTLO	OB
13	+5VD	
14	GP18	OA

**Table 2-1. RC9623DP Modem Device Pin Signals (Continued)**

Pin Number	Signal Name	I/O Type
15	GP16	OA
16	XTCLK	IA
17	DGND1	
18	TXD	IA
19	TDCLK	OA
20	TRSTO	MI
21	TSTBO	MI
22	TDACO	MI
23	RADCI	MI
24	RAGCO	MI
25	MODEO	MI
26	RSTBO	MI
27	RRSTO	MI
28	$\overline{\text{RDCLK}}$	OA
29	RXD	OA
30	TXA2	O(DD)
31	TXA1	O(DD)
32	RXA	I(DA)
33	RFILO	MI
34	AGCIN	MI
35	VC	
36	NC	
37	NC	
38	NC	
39	$\overline{\text{RBDVR}}$	OD
40	AGND	
41	$\overline{\text{RADRV}}$	OD
42	$\overline{\text{SLEEP1}}$	IA
43	RAGCI	MI
44	NC	
45	RSTBI	MI

**Table 2-1. RC9623DP Modem Device Pin Signals (Continued)**

Pin Number	Signal Name	I/O Type
46	RRSTI	MI
47	RADCO	MI
48	TDACI	MI
49	TRSTI	MI
50	TSTBI	MI
51	MODE1	MI
52	+5VA	
53	SPKR	O(OF)
54	DGND2	
55	D7	IA/OB
56	D6	IA/OB
57	D5	IA/OB
58	D4	IA/OB
59	D3	IA/OB
60	D2	IA/OB
61	D1	IA/OB
62	D0	IA/OB
63	$\overline{\text{IRQ}}$	OC
64	$\overline{\text{WRITE}}$	IA
65	$\overline{\text{CS}}$	IA
66	$\overline{\text{READ}}$	IA
67	RS4	IA
68	RS3	IA
<p>Notes:</p> <p>(1) MI = Modem Interconnection</p> <p>(2) NC = No connection (may have internal connection; leave pin disconnected (open)).</p> <p>(3) I/O types are described in Table 2-3 (digital signals) and Table 2-4 (analog signals).</p>		

Table 2-2. Hardware Interface Signal Definitions

Label	I/O Type	Signal/Definition
		<b>OVERHEAD SIGNALS</b>
XTLI	IEOB	<b>Crystal/Clock In and Crystal Out.</b> The DSP must be connected to an external crystal circuit consisting of a 24.00014 MHz crystal and two capacitors. Alternatively, XTLI, may be driven with a buffered clock (e.g., square wave generator) or a sine wave oscillator.
$\overline{\text{RESET}}$	ID	<b>Reset.</b> The active low RESET input resets the internal modem logic. Upon transition of RESET from low-to-high, the DSP interface memory bits are set to the default values.
+5VD	PWR	<b>+5V Digital Supply.</b> +5V $\pm$ 5% is required.
+5VA	PWR	<b>+5V Analog Supply.</b> +5V $\pm$ 5% is required.
DGND	GND	<b>Digital Ground.</b>
DGND	GND	<b>Analog Ground.</b>
		<b>SERIAL INTERFACE</b>
		Five TTL-level hardware interface circuits implement a CCITT V.24-compatible serial data interface with control signals provided through the DSP interface memory.
$\overline{\text{RDCLK}}$	OA	<b>Receive Data Clock.</b> In synchronous mode, the modem outputs a Receive Data Clock (RDCLK in the form of 50 $\pm$ 1% duty cycle square wave. The low-to-high transitions of this output coincide with the center of received data bits.
TDCLK	OA	<b>Transmit Data Clock.</b> In synchronous mode, the modem outputs a Transmit Data Clock (TDCLK). The TDCLK clock frequency is data rate $\pm$ 0.01% with a duty cycle of 50 $\pm$ 1%.
XTCLK	IA	<b>External Transmit Clock.</b> In synchronous mode, an external transmit data clock input (XTCLK) can be supplied.
RXD	OA	<b>Received Data.</b> The modem presents received serial data on the Received Data (RXD) output and to the interface memory Receive Data Register (RBUFFER) in both serial and parallel modes.
TXD	IA	<b>Transmitted Data.</b> The modem obtains serial data to be transmitted on the TXD input in serial mode, or from the interface memory Transmit Data Register (TBUFFER) in parallel mode. (See TPDM bit.)
		<b>PARALLEL MICROPROCESSOR INTERFACE</b>
		Address, data, control and interrupt hardware interface signals implement an 8086-compatible parallel microprocessor interface to a host processor. This parallel interface allows the host to change modem configuration, read or write channel and diagnostic data, and supervise modem operation by writing control bits and reading status bits.
D0-D7	IA/OA	<b>Data Lines.</b> Eight bidirectional data lines (D0-D7) provide parallel transfer of data between the host and the modem.
$\overline{\text{CS}}$	IA	<b>Chip Select.</b> The active low Chip Select ( $\overline{\text{CS}}$ ) input enables parallel data transfer over the microprocessor bus.



Table 2-2. Hardware Interface Signal Definitions (Continued)

Label	I/O Type	Signal/Definition
RS0-RS4	IA	<b>PARALLEL MICROPROCESSOR INTERFACE (con't)</b> <b>Register Select Lines.</b> The five active high Register Select inputs (RS0 - RS4) address Interface memory registers in the modem when $\overline{CS}$ is low. These lines are typically connected to address lines A0-A4 to address one of 32 8-bit internal interface memory registers (00-1F). The selected register can be read from, or written into, via the 8-bit parallel data bus (D0-D7).
$\overline{READ}$ $\overline{WRITE}$	IAIA	<b>Read Enable and Write Enable.</b> Reading or writing is controlled by the host pulsing either $\overline{READ}$ or $\overline{WRITE}$ input low, respectively, during the microprocessor bus access cycle.  During a write cycle, data from the data bus is copied into the addressed DSP interlace memory register, with high and low bus levels representing one and zero bit states, respectively.
$\overline{IRQ}$	OA	<b>Interrupt Request.</b> The $\overline{IRQ}$ output structure is an open-drain field-effect-transistor (FET). The $\overline{IRQ}$ output can be enabled in the interface memory to allow immediate indication of change of conditions in the modem. The use of $\overline{IRQ}$ is optional depending upon modem application.
TXA1 TXA2	O(DF)	<b>HYBRID CIRCUIT</b> <b>Transmit Analog 1 and 2.</b> The TXA1 and TXA2 outputs are differential outputs 180 degrees out of phase with each other.
RXA	I(DA)	<b>Receive Analog.</b> RXA is a single-ended receive data input from the telephone line interface or an optional external hybrid circuit.
VC	OA	<b>Centerpoint Voltage.</b> VC is a +2.5 VDC centerpoint voltage which serves as the internal 'analog ground' reference point.
$\overline{RADVR}$	OD	<b>TELEPHONE LINE INTERFACE</b> <b>Relay A Driver.</b> $\overline{RADVR}$ is an open drain output which can directly drive a relay with greater than 360 Q coil resistance and having a 'must operate' voltage of no greater than 4.0 VDC.  The $\overline{RADVR}$ output is controlled by the state of the RA bit, except in pulse dial mode. When RA is a 1, the $\overline{RADVR}$ output is active which applies current to the relay coil.  In a typical application, $\overline{RADVR}$ is connected to the normally open Off-Hook relay. In this case, $\overline{RADVR}$ active closes the Off-Hook relay to connect the modem to the telephone line.
$\overline{RBDVR}$	OD	<b>Relay B Driver.</b> $\overline{RBDVR}$ is an open drain output which can directly drive a relay with greater than 360 Q coil resistance and having a 'must operate' voltage of no greater than 4.0 VDC.  $\overline{RBDVR}$ output is controlled by the state of the RB bit. When RB is a 1, the $\overline{RBDVR}$ output is active which applies current to the relay coil.  In a typical application, $\overline{RBDVR}$ is connected to the normally closed Talk/Data relay. In this case, $\overline{RBDVR}$ active opens the relay to disconnect the handset from the telephone line.
$\overline{RING}$	IA	<b>Ring Frequency.</b> A low-going edge on the $\overline{RING}$ input initiates a ring frequency measurement. A valid ring detection is indicated by the RI bit.

Table 2-2. Hardware Interface Signal Definitions (Continued)

Label	I/O Type	Signal/Definition
SPKR	O(DF)	<p><b>SPEAKER INTERFACE</b></p> <p><b>Speaker Analog Output.</b> The SPKR output reflects the received analog input signal. The SPKR on/off and three levels of attenuation are controlled by interface memory bits. When the speaker is turned off, the SPKR output is clamped to the voltage at the VC pin. The SPKR output can drive an impedance as low as 300 ohms. In a typical application, the SPKR output is an input to an external LM386 audio power amplifier.</p>
$\overline{\text{SLEEP}}$ $\overline{\text{SLEEP1}}$	OA IA	<p><b>SLEEP MODE SIGNALS</b></p> <p><b>Sleep Mode Output and Sleep Mode Input.</b> <math>\overline{\text{SLEEP}}</math> output high indicates the DSP is operating in its normal mode. <math>\overline{\text{SLEEP}}</math> low indicates that the DSP is in the sleep mode. This signal must be connected to the <math>\overline{\text{SLEEP1}}</math> input to power down the IA in the sleep mode. <math>\overline{\text{SLEEP}}</math> can also be used to control power to other devices (e.g., as a speaker enable).</p>
EYEX, EYEV $\overline{\text{EYECLK}}$ (RRSTO) EYESYNC	OB OA OB	<p><b>DIAGNOSTIC SIGNALS</b></p> <p>Four signals provide the timing and data necessary to create an oscilloscope quadrature eye pattern. The eye pattern is simply a display of the received baseband constellation. By observing this constellation, common line disturbances can usually be identified.</p> <p><b>Eye Pattern Data X and Eye Pattern Data Y.</b> The EYEX and EYEV outputs provide two serial bit streams containing data for display on the oscilloscope horizontal (X) axis and vertical (Y) axis, respectively. This serial digital data can be converted to analog form using two shift registers and two digital-to-analog converters (DACs).</p> <p><b>Eye Pattern Clock.</b> <math>\overline{\text{EYECLK}}</math> is a clock for use by the serial-to-parallel converters. The <math>\overline{\text{EYECLK}}</math> output is a 7200/9600 Hz clock.</p> <p><b>Eye Pattern Sync.</b> EYESYNC is a strobe for word synchronization. The falling edge of EYESYNC may be used to transfer the 8-bit word from the shift register to a holding register. Digital-to-analog conversion can then be performed for driving the X and Y inputs of an oscilloscope.</p>
RFILO AGCIN MODEO (DSP) MODEI (IA) TDACO (DSP), TDACI (IA) TSTBO (DSP), TSTBI (IA) TRSTO (DSP), TRSTI (IA)	MI MI MI MI MI MI	<p><b>MODEM INTERCONNECT</b></p> <p><b>Receive Filter Output.</b> RFILO is the output of the internal receive analog filter which must be connected to AGCIN through a 0.1 <math>\mu\text{F}</math>, 20%, DC decoupling capacitor.</p> <p><b>Receive AGC Gain Amplifier Input.</b> See RFILO.</p> <p><b>Mode Control.</b> Serial IA mode control bits. Direct modem interconnect line.</p> <p><b>Transmitter DAC Signal.</b> Transmitter serial digital DAC signal. Direct modem interconnect line.</p> <p><b>Transmitter Strobe.</b> Transmitter 576 kHz digital timing reference. Direct modem interconnect line.</p> <p><b>Transmitter Reset.</b> Transmitter 7200/9600 Hz digital timing reference. Direct modem interconnect line.</p>

## Single Device Data/Modem Data Pump

Table 2-2. Hardware Interface Signal Definitions (Continued)

Label	I/O Type	Signal/Definition
RADCI (DSP), RADCO (IA)	MI	<b>MODEM INTERCONNECT (con't)</b> <b>Receiver ADC Signal.</b> Receiver serial digital ADC signal. Direct modem interconnect line.
RAGCO (DSP), RAGCI (IA)	MI	<b>Receiver AGC Signal.</b> Receiver serial digital AGC signal. Direct modem interconnect line.
RSRBO (DSP), RSRBI (IA)	MI	<b>Receiver Strobe.</b> Receiver 576 kHz digital timing reference. Direct modem interconnect line.
RRSTO (DSP), RRSTI (IA)	MI	<b>Receiver Reset.</b> Receiver 7200/9600 Hz digital timing reference. Direct modem interconnect line.

Table 2-3. Digital Interface Characteristics

Parameter	Symbol	Min.	Typ.	Max.	Units	Test Conditions <sup>(1)</sup>
Input High Voltage Type IA Type ID	$V_{IH}$	2.0 0.8 (V <sub>CC</sub> )	– –	V <sub>CC</sub> V <sub>CC</sub>	Vdc	
Input Low Voltage	$V_{IL}$	-0.3	–	0.8	Vdc	
Input Low Current	$I_{IL}$	–	–	-400	μA	V <sub>CC</sub> = 5.25V
Output High Voltage Types OA and OB Type OD	$V_{OH}$	3.5 –	– –	– V <sub>CC</sub>	Vdc	$I_{LOAD} = -100 \mu A$ $I_{LOAD} = 0 \text{ mA}$
Output Low Voltage Types OA and OC Type OB Type OD	$V_{OL}$	– – –	– – –	0.4 0.4 0.75	Vdc	$I_{LOAD} = 1.6 \text{ mA}$ $I_{LOAD} = 0.8 \text{ mA}$ $I_{LOAD} = 15 \text{ mA}$
Three-State Input Current (Off)	$I_{TSI}$	–	–	±10	μA	V <sub>IN</sub> = 0.4 to V <sub>CC</sub> -1
Power Dissipation Operating Sleep	$P_D$	– –	300 15	450 22.5	mW	
Note: (1) Test Conditions: V <sub>CC</sub> = 5V ±5%, T <sub>A</sub> = 0°C to 70°C (unless otherwise noted).						

**Table 2-4. Analog Interface Characteristics**

<b>Name</b>	<b>Type</b>	<b>Characteristic</b>
RXA	I (DA)	1458 type op amp input
TXA1, TXA2	O (DD)	1458 type op amp output
SPKR	O (DF)	1458 type op amp output

## 3.0 Software Interface

---

### 3.1 Interface Memory

The DSP communicates with the host by means of a dual-port, interface memory. The interface memory in the DSP contains thirty-two 8-bit registers, labeled register 00 through 1F. Each register can be read from, or written into, by both the host and the DSP. The host communicates with the DSP interface memory via the microprocessor bus.

The host can control modem operation by writing control bits to DSP interface memory and writing parameter values to DSP RAM through the interface memory. The host can monitor modem operation by reading status bits from DSP interface memory and reading parameter values from DSP RAM through interface memory.

### 3.2 Interface Memory Map

A memory map of DSP interface memory identifying the contents of the 32 addressable registers is shown in Table 3-1. These 8-bit registers may be read or written during any host read or write cycle. In order to operate on a single bit or group of bits in a register, the host must read a register then mask out unwanted data. When writing a single bit or group of bits in a register, the host must perform a read-modify-write operation. That is, the host must read the entire register, set or reset the necessary bits without altering the other register bits, then write the unaffected and modified bits back into the interface memory register.

### 3.3 Interface Memory Bit Functions

Table 3-2 summarizes the functions of the individual bits in the interface memory. Bits in the interface memory are referred to using the format Z:Q. The register number is denoted by Z (00 through 1F) and the bit number is located by Q (0 through 7, where 0 = LSB).

## 3.3 Interface Memory Bit Functions

Single Device Data/Modem Data Pump

Table 3-1. Interface Memory Map

Register Function	Register Address (Hex)	Bit							
		7	6	5	4	3	2	1	0
Interrupt Handling	1F	NSIA	NCIA	–	NSIE	NEWS	NCIE	–	NEWC
	1E	TDBIA	RDBIA	TDBIE	–	TDBE	RDBIE	–	RDBF
RAM Access, Control and Status	1D	XACC	–	–	–	IOX	XCRD	XWT	XCR
	1C	X RAM ADDRESS (XADD)							
	1B	YACC	–	–	–	–	YCRD	YWT	YCR
	1A	Y RAM ADDRESS (YADD)							
	19	X RAM DATA MSB (XDAM)							
	18	X RAM DATA LSB (XDAL)							
	17	Y RAM DATA MSB (YDAM)							
	16	Y RAM DATA LSB (YDAL)							
	–	15	–	–	–	–	–	–	–
–	14	–	–	–	–	–	–	–	
Control	13	TLVL				VOL		TXCLK	
	12	CONFIGURATION (CONF)							
Transmit Data Buffer	11	–	–	–	–	–	–	–	TXP
	10	TRANSMIT DATA BUFFER (TBUFFER)							
Status	0F	RLSD	FED	CTS	DSR	RI	TM	SYNCD	FLAGS
	0E	RTDET	BRKD	PE	FE	OE	SPEED		
	0D	–	PNDDET	S1DET	SCR1	U1DET	SADET	–	–
	0C	EDET	–	–	–	DTDIG			
	0B	TONEA	TONEB	TONEC	ATV25	ATBELL	PNSUC	DTDET	BEL103
	0A	–	–	–	–	–	–	–	CRCS
Control	09	NV25	CC	DTMF	ORG	LL	DATA	–	SLEEP
	08	ASYNCR	TPDM	–	DDIS	TRFZ	–	RTRN	RTS
	07	RDLE	RDL	L2ACT	–	L3ACT	RB	RA	ABORT
	06	BRKS	EXOS	PARSL		PEN	STB	WDSZ	
	05	–	–	–	TXSQ	CEQE	RCEQ	TXVOC	–
	04	EQRES	SWRES	–	–	EQFZ	IFIX	AGCFZ	CRFZ
	03	NRZIE	HDLC	SPLIT	–	ARC	SDIS	GTE	–
	02	–	–	–	–	–	–	–	–
Receive Data Buffer	01	–	–	–	–	–	–	–	RXP
	00	RECEIVE DATA BUFFER (RBUFFER)							

Note: '–' in the BIT columns indicates reserved for modem use only.

Table 3-2. Interface Memory Bit Functions

Mnemonic	Memory Location	Name/Description
ABORT	07:0	<b>HDLC Abort.</b> Controls sending of continuous mark in HDLC mode.
AGCFZ	04:1	<b>AGC Freeze.</b> inhibits updating of the receiver AGC.
ARC	03:3	<b>Automatic Rate Change Enable.</b> Enables automatic on-line rate change sequence.
ASync	08:7	<b>Asynchronous/Synchronous.</b> Selects asynchronous or synchronous data mode.
ATBELL	0B:3	<b>Bell Answer Tone Detected.</b> Reports detection status of 2225 Hz answer tone.
ATV25	0B:4	<b>V25 Answer Tone Detected.</b> Reports detection status of 2100 Hz answer tone.
BEL103	0B:0	<b>Bell 103 Mark Frequency Detected.</b> Reports detection status of 1270 Hz Bell 103 mark.
BRKD	0E:6	<b>Break Detected.</b> Reports receipt status of continuous space.
BRKS	06:7	<b>Break Sequence.</b> Controls sending of continuous space in parallel asynchronous mode.
CC	09:6	<b>Controlled Carrier.</b> Selects controlled or constant carrier mode.
CEQ	05:3	<b>Compromise Equalizer Enable.</b> Enables the transmit passband digital compromise equalizer.
CONF	12:0-7	<b>Modem Configuration Select.</b> Selects the modem operating mode.
CRCS	0A:0	<b>CRC Sending.</b> Reports the sending status of the CRC (2 bytes) in HDLC mode.
CRFZ	04:0	<b>Carrier Recovery Freeze.</b> Disables update of the receiver's carrier recovery phase lock loop.
CTS	0F:5	<b>Clear to Send.</b> Reports that the training sequence has been completed (see TPDM).
DATA	09:2	<b>Data Mode.</b> Selects idle or data mode.
DDIS	08:4	<b>Descrambler Disable.</b> Disables the receiver's descrambler circuit.
DSR	0F:4	<b>Data Set Ready.</b> Reports the data transfer state.
DTDET	0B:1	<b>DTMF Digit Detected.</b> Reports that a valid DTFM digit has been detected.
DTDIG	00:0-3	<b>Detected DTMF Digit.</b> Contains the hexadecimal code of the detected DTMF digit.
DTMF	09:5	<b>DTMF Dial Select.</b> Selects either DTMF or pulse dialing in the dial mode.
EDET	00:7	<b>Early DTMF Detect.</b> Reports detection of the high group frequency of the DTMF tone pair.
EQFZ	04:3	<b>Equalizer Freeze.</b> inhibits the update of the receiver's adaptive equalizer taps.
EQRES	04:7	<b>Equalizer Reset.</b> Resets the receiver adaptive equalizer taps to zero.
EXOS	06:6	<b>Extended Overspeed.</b> Selects extended overspeed mode in asynchronous mode.
FE	0E:4	<b>Framing Error.</b> Reports framing error detection or detection of an ABORT sequence.
FED	0F:6	<b>Fast Energy Detected.</b> Reports energy above the turn-on threshold is being detected.

Table 3-2. Interface Memory Bit Functions (Continued)

Mnemonic	Memory Location	Name/Description
FLAGS	0F:0	<b>Flag Sequence.</b> Reports transmission status of the Flag sequence in HDLC mode, or transmission of a constant mark in parallel asynchronous mode.
GTE	03:1	<b>Guard Tone Enable.</b> Enables transmission of the 1800 Hz guard tone (CCITT configuration only).
HDLC	03:6	<b>High Level Data Link Control.</b> Enables HDLC protocol support in parallel data mode.
IFIX	04:2	<b>Eye Fix.</b> Forces EYEX and EYEV serial data to be rotated equalizer output.
IOX	1D:3	<b>I/O Register Select.</b> Specifies that the X RAM ADDRESS (XADD) is an internal I/O register address.
L2ACT	07:5	<b>Loop 2 (Local Digital Loopback) Activate.</b> Selects connection of the receiver's digital output Internally to the transmitter's digital input (locally activated digital loopback).
L3ACT	07:3	<b>Loop 3 (Local Analog Loopback) Activate.</b> Selects connection of the transmitter's analog output Internally to the receiver's analog input (local analog loopback).
LL	09:3	<b>Leased Line.</b> Selects leased line data mode or handshake mode.
NCIA	1F:6	<b>NEWC Interrupt Active.</b> Reports that the cause of an interrupt request was completion of a configuration change. (See NEWC and NCIE.)
NCIE	1F:2	<b>NEWC interrupt Enable.</b> Enables the assertion of $\overline{IRQ}$ and the setting of the NCIA bit.
NEWC	1F:0	<b>New Configuration.</b> Initiates a new configuration; cleared by the modem upon completion of configuration change. This bit can cause $\overline{IRQ}$ to be asserted. (See NCIE and NCIA.)
NEWS	1F:3	<b>New Status.</b> Reports the detection of a change in selected status bits. This bit can cause $\overline{IRQ}$ to be asserted. (See NSIE and NSIA.)
NSIA	1F:7	<b>NEWS Interrupt Active.</b> Reports that the cause of an interrupt request was a status bit change. (See NEWS and NSIE.)
NSIE	1F:4	<b>NEWS interrupt Enable.</b> Enables the assertion of $\overline{IRQ}$ and the setting of the NSIA bit. (See NEWS.)
NV25	09:7	<b>Disable V.25 Answer Sequence (Data Modes), Disable Echo Suppressor Tone (Fax Modes).</b> Disables the transmitting of the 2100 Hz CCI1T answer tone when a handshake sequence is initiated in a data mode or disables sending of the echo suppressor tone in a fax mode.
OE	0E:3	<b>Overrun Error.</b> Reports overrun status of the Receiver Data Buffer (RBUFFER).
ORG	09:4	<b>Originate.</b> Selects originate or answer mode.
PE	0E:5	<b>Parity Error.</b> Reports parity error status or bad CRC
PNSUC	0B:2	<b>PN Success.</b> Indicates that the receiver has detected the PN portion of the training sequence.
RA	07:1	<b>Relay A Activate.</b> Activates the $\overline{RADR\overline{V}}$ output.
PARSL	06:4.5	<b>Parity Select.</b> Selects stuff, space, even, or odd parity in the asynchronous parallel data mode.



**Table 3-2. Interface Memory Bit Functions (Continued)**

Mnemonic	Memory Location	Name/Description
RB	07:2	<b>Relay B Activate.</b> Activates the $\overline{\text{RBDVR}}$ output.
RBUFFER	00:0-7	<b>Receive Data Buffer.</b> Contains the received byte of data.
RDBF	1E:0	<b>Receiver Data Buffer Full.</b> Reports the status (full or not full) of the Receiver Data Buffer (RBUFFER). (See RDBIE and RDBIA.)
RDBIA	1E:6	<b>Receiver Data Buffer interrupt Active.</b> Reports that the cause of an interrupt request is the Receiver Data Buffer (RBUFFER) full. (See RDBF and RDBIE.)
RDBIE	1E:2	<b>Receiver Data Buffer interrupt Enable.</b> Enables the assertion of $\overline{\text{IRQ}}$ and the setting of the RDBIA bit when RBUFFER is full. (See RDBF and RDBIA.)
RDL	07:6	<b>Remote Digital Loopback Request.</b> initiates a request for the remote modem to go into digital loop-back.
RDLE	07:7	<b>Remote Digital Loopback Response Enable.</b> Enables the modem to respond to the remote modem's digital loopback request.
PEN	06:3	<b>Parity Enable.</b> Enables generation/checking of parity in asynchronous parallel data mode.
RCEQ	05:2	<b>Receiver Compromise Equalizer Enable.</b> Controls insertion of the receive passband digital compromise equalizer into the receive path.
RI	0F:3	<b>Ring Indicator.</b> Reports detection status of a valid ringing signal.
RTDET	0E:7	<b>Retrain Detected.</b> Reports detection status of a retrain request sequence.
RTRN	08:1	<b>Retrain.</b> Controls sending of the retrain request or automatic rate change to the remote modem.
RTS	08:0	<b>Request to Send.</b> Requests the transmitter to send data.
RLSD	0F:7	<b>Received Line Signal Detector.</b> Reports detection status of the carrier and the receipt of valid data.
RXP	01:0	<b>Received Parity bit.</b> This bit is the received parity bit (or ninth data bit).
S1DET	00:5	<b>S1 Sequence Detected.</b> Reports detection status of the S1 sequence.
SADET	00:2	<b>Scrambled Alternating Ones Sequence Detected.</b> Reports detection status of the Scrambled Alternating Ones sequence.
SCR1	00:4	<b>Scrambled Ones Sequence Detected.</b> Reports detection status of Scrambled Ones sequence.
SDIS	03:2	<b>Scrambler Disable.</b> Disables the transmitter scrambler.
SLEEP	09:0	<b>Sleep Mode.</b> Controls entry into the SLEEP mode. The modem requires a pulse on the RESET pin to return to normal operation.
SPEED	0E:0-2	<b>Speed Indication.</b> Reports the data rate at the completion of a connection.
SPLIT	03:5	<b>Extended Overspeed TX/RX Split.</b> Limits transmit data to the basic overspeed rate.
STB	06:2	<b>Stop Bit Number.</b> Selects the number of stop bits in asynchronous mode.
SWRES	04:6	<b>Software Reset.</b> Causes the modem to reinitialize to its power turn-on state.

Table 3-2. Interface Memory Bit Functions (Continued)

Mnemonic	Memory Location	Name/Description
TBUFFER	10:0-7	<b>Transmitter Data Buffer.</b> Contains the byte to be transmitted in the parallel mode.
TDBE	1E:3	<b>Transmitter Data Buffer Empty.</b> Reports the status (empty or not empty) of the Transmit Data Buffer (TBUFFER). (See TDBIE and TDBIA.)
TDBIA	1E:7	<b>Transmitter Data Buffer Interrupt Active.</b> Reports that the cause of an interrupt request is the Transmit Data Buffer (TBUFFER) empty. (See TDBE and TDBIE.)
TDBIE	1E:5	<b>Transmitter Data Buffer interrupt Enable.</b> Enables assertion of $\overline{IRQ}$ and the setting of the TDBIA bit when the TBUFFER is empty. (See TDBE and TDBIA.)
TLVL	13:4-7	<b>Transmit Level Attenuation Select.</b> Selects the transmitter analog output level attenuation in 1 dB steps. The host can fine tune the transmit level to a value lying within a 1 dB step in DSP RAM.
TM	0F:2	<b>Test Mode.</b> Reports active status of the selected test mode.
TONEA	0B:7	<b>Tone Filter A Energy Detected.</b> Reports status of energy above the threshold detection by the Call Progress Monitor filter in the Dial Configuration or 1300 Hz FSK tone energy detection by the Tone A bandpass filter in the Tone Detector configuration.
TONEB	0B:6	<b>Tone Filter B Energy Detected.</b> Reports status of 390 Hz FSK tone energy detection by the Tone B bandpass filter in the Tone Detector configuration.
TONEC	05:5	<b>Tone Filter C Energy Detected.</b> Reports status of 1650 Hz or 980 Hz (selected by the ORG bit) FSK tone energy detection by the Tone C bandpass filter in the Tone Detector configuration.
TPDM	08:6	<b>Transmitter Parallel Data Mode.</b> Selects transmitter parallel or serial mode.
TRFZ	08:3	<b>Timing Recovery Freeze.</b> Inhibits the update of the receiver's timing recovery algorithm.
TXCLK	13:0,1	<b>Transmit Clock Select.</b> Selects the transmitter data clock (internal, disable, slave, or external).
TXP	11:0	<b>Transmit Parity Bit (or 9th Data Bit).</b> This bit is the stuffed parity bit (or ninth data bit) for transmission.
TXSQ	05:4	<b>Transmitter Squelch.</b> Disables transmission of energy.
TXVOC	05:1	<b>Transmit Voice.</b> Enables the sending of voice samples.
U1DET	0D:3	<b>Unscrambled Ones Detected.</b> Reports detection status of the Unscrambled Ones sequence.
WDSZ	06:0,1	<b>Data Word Size.</b> Selects the number of data bits per character in asynchronous mode (5, 6, 7, or 8).
VOL	13:2-3	<b>Volume Control.</b> Two-bit encoded speaker volume selects volume off or one of three volume on levels.
XACC	1D:7	<b>X RAM Access Enable.</b> Controls DSP access of the X RAM associated with the address in XADD and the XCR bit. XWT determines if a read or write is performed.
XADD	1C:0-7	<b>X RAM Address.</b> Contains the X RAM address used to access the DSP's X Data RAM or X Coefficient RAM (selected by XCR) via the X RAM Data LSB and MSB registers.

**Table 3-2. Interface Memory Bit Functions (Continued)**

Mnemonic	Memory Location	Name/Description
XCR	1D:0	<b>X Coefficient RAM Select.</b> Controls XADD access to the DSP's X Coefficient RAM or the X Data RAM.
XCRD	1D:2	<b>X RAM Continuous Read.</b> Enables read of X RAM every sample from the location addressed by XADD independent of the XACC and XWT bits.
XDAL	18:0-7	<b>X RAM Data LSB.</b> The least significant byte of the 16-bit X RAM data word used in reading or writing X RAM locations in the DSR
XDAM	19:0-7	<b>X RAM Data MSB.</b> The most significant byte of the 16-bit X RAM data word used in reading or writing X RAM locations in the DSR
XWT	1D:1	<b>X RAM Write.</b> Controls the reading of data from, or the writing of data to, the X RAM Data registers (18 and 19) using the X RAM location addressed by XADD and XCR.
YACC	1B:7	<b>Y RAM Access Enable.</b> Controls DSP access of the Y RAM associated with the address in YADD and the YCR bit. YWT determines if a read or write is performed.
YADD	1A0-7	<b>Y RAM Address.</b> Contains the Y RAM address used to access the DSP's V Data RAM or V Coefficient RAM (selected by YCR) via the Y RAM Data LSB and MSB registers.
YCR	15:0	<b>Y Coefficient RAM Select.</b> Controls YADD access to the DSP's Y Coefficient RAM or the Y Data RAM.
YCRD	15:2	<b>Y RAM Continuous Read.</b> Enables read of Y RAM every sample from the location addressed by YADD independent of the YACC and YWT bits.
YDAL	16:0-7	<b>Y RAM Data LSB.</b> The least significant byte of the 16-bit Y RAM data word used in reading or writing Y RAM locations in the DSP
YDAM	17:0-7	<b>Y RAM Data MSB.</b> The most significant byte of the 16-bit Y RAM data word used in reading or writing Y RAM locations in the DSP.
YWT	1B:1	<b>Y RAM Write.</b> Controls the reading of data from, or the writing of data to, the Y RAM Data registers (16 and 17) using the Y RAM location addressed by YADD and YCR.

### 3.4 DSP RAM Access

The DSP contains four sections of 16-bit wide random access memory (RAM). Because the DSP is optimized for performing complex arithmetic, the RAM is organized into real (X RAM) and imaginary (Y RAM) sections, as well as data and coefficient sections. The host processor can access (read or write) the X RAM only, the Y RAM only, or both the X RAM and the Y RAM simultaneously in either the data or coefficient section.

### 3.5 Interface Memory Access to DSP RAM

The DSP Interface memory acts as an intermediary during host to DSP RAM or DSP RAM to host data exchanges. The addresses stored in modem Interface memory RAM Address registers (i. e., XADD and YADD) by the host, in conjunction with the data or coefficient RAM bits (i. e., XCR and YCR) determine the DSP RAM addresses for data access.

### 3.6 Host Programmable Data

The parameters available In DSP RAM are listed in Table 3-3 along with the X RAM or Y RAM address and corresponding XCR or YCR bit value. The scaling for the host programmable data is described in the Modem Designer's Guide.

**Table 3-3. DSP RAM Parameters**

No.	XCR/YCR <sup>(1)</sup>	X RAM Addr	Y RAM Addr	Parameter
1	1	0-1E		Adaptive Equalizer Coefficients, Real
	1	0	–	First coefficient, Real (1) (Data/Fax)
	1	10	–	Last Coefficient, Real (17) (Data)
	1	1E	–	Last Coefficient, Real (31) (Fax)
2	1		0-1E	Adaptive Equalizer Coefficients, Imag.
	1	–	0	First Coefficient, Imag. (1) (Data/Fax)
	1	–	10	Last Coefficient, Imag. (17) (Data)
	1	–	1E	Last Coefficient, Imag. (31) (Fax)
3	0	49	–	Rotated Error, Real
4	0	–	49	Rotated Error, Imaginary
5	0	3F	–	Max AGC Gain Word
6	0	71	–	Pulse Dial Interdigit Time
7	0	7C	–	Tone Dial Interdigit Time
8	0	72	–	Pulse Dial Relay Make Time
9	0	7D	–	Pulse Dial Relay Break Time
10	0	7E	–	DTMF Duration

**Table 3-3. DSP RAM Parameters (Continued)**

No.	XCR/YCR <sup>(1)</sup>	X RAM Addr	Y RAM Addr	Parameter
11	0	6C	–	Tone 1 Angle Increment Per Sample (TXDPHI1)
12	0	6D	–	Tone 2 Angle Increment Per Sample (TXDPHI2)
13	0	6E	–	Tone 1 Amplitude (TXAMP1)
14	0	6F	–	Tone 2 Amplitude (TXAMP2)
15	0	73	–	Max Samples Per Ring Frequency Period (RDMAXP)
16	0	74	–	Min Samples Per Ring Frequency Period (RDMINP)
17	0	5E	–	Real Part of Error
18	0	–	5E	Imaginary Part of Error
19	0	–	3D	Rotation Angle for Carrier Recovery
20	0	59	–	Rotated Equalizer Output, Real
21	0	–	59	Rotated Equalizer Output, Imaginary
22	0	3C	–	Lower Part of Phase Error
23	0	–	3C	Upper Part of Phase Error
24	1	3F	–	Upper Part of AGC Gain Word
25	1	3E	–	Lower Part of AGC Gain Word
26	1	2E	–	Average Power
27	1	2D	–	Phase Error
28	1	2F	–	Tone Power (TONEA)
29	1	30	–	Tone Power (ATBELL, BEL103, or TONEB)
30	1	31	–	Tone Power (TONEC, ATV25)
31	1	36	–	Tone Detect Threshold for TONEA (THDA)
32	1	37	–	Tone Detect Threshold for ATBELL, BEL103, or TONEB (THDB)
33	1	38	–	Tone Detect Threshold for TONEC or ATV25 (THDC)

Table 3-3. DSP RAM Parameters (Continued)

No.	XCR/YCR <sup>(1)</sup>	X RAM Addr	Y RAM Addr	Parameter
34	1	–	6C	Biquad 1 Coefficient $\alpha_0$
	1	–	6D	Biquad 1 Coefficient $\alpha_1$
	1	–	6E	Biquad 1 Coefficient $\alpha_2$
	1	–	6F	Biquad 1 Coefficient $\beta_1$
	1	–	70	Biquad 1 Coefficient $\beta_2$
	1	–	71-75	Biquad 2 Coefficients $\alpha_0 - \beta_2$
	1	–	76-7A	Biquad 3 Coefficients $\alpha_0 - \beta_2$
	1	–	7B-7F	Biquad 4 Coefficients $\alpha_0 - \beta_2$
	1	–	62-66	Biquad 5 Coefficients $\alpha_0 - \beta_2$
	1	–	67-6B	Biquad 6 Coefficients $\alpha_0 - \beta_2$
35	0	32	–	Turn-on Threshold
36	1	79	–	Turn-off Threshold
37	1	–	21	RLSD Turn-off Time
38	0	70	–	Transmit Level Output Attenuation
39	1	52	–	Eye Quality Monitor (EQM)
Note: (1)XCR if an XRAM address is listed; YCR if a YRAM address is listed.				

### 3.7 Modem Interface Circuit

The recommended modem Interface circuit is shown in Figure 3-1.

Figure 3-1. Typical Modem Interface Circuit

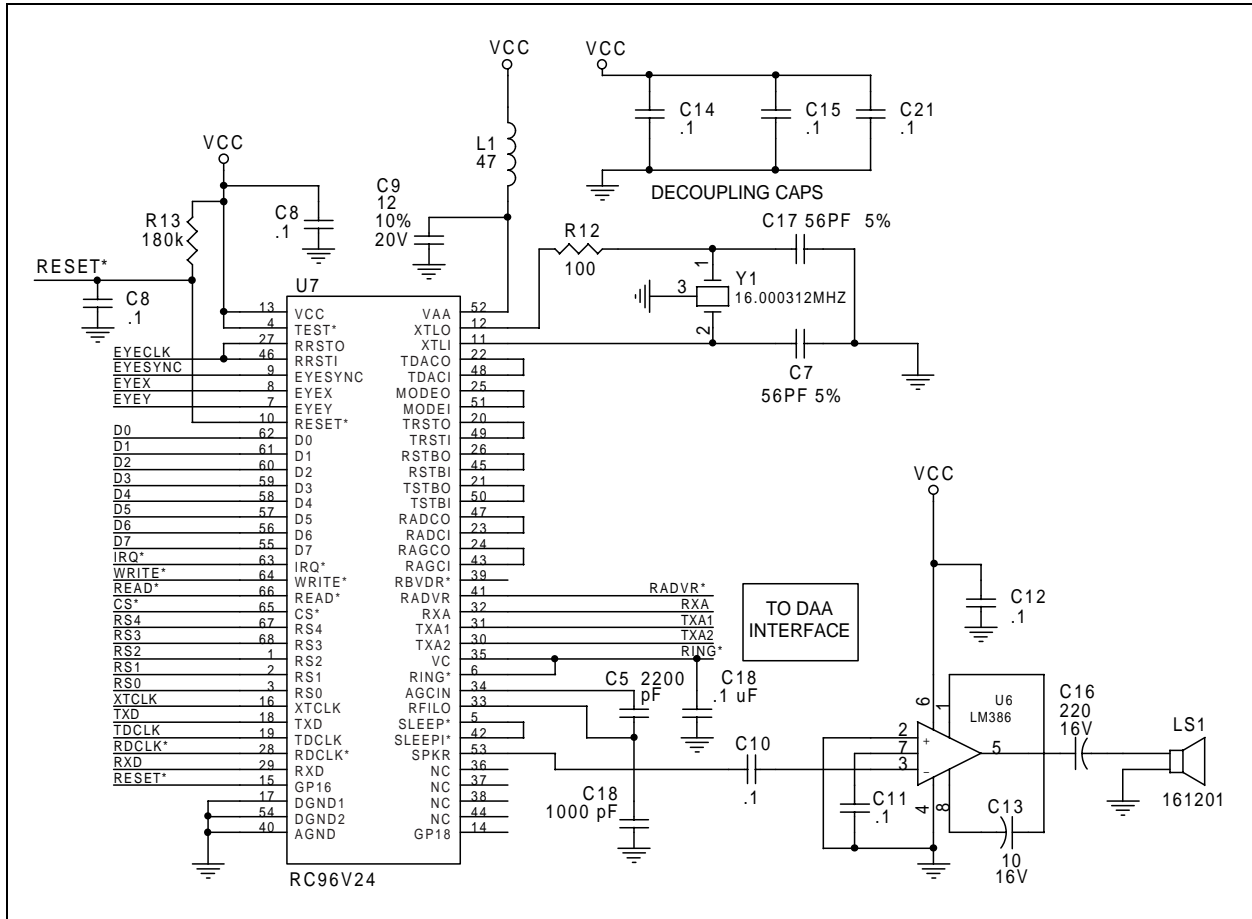
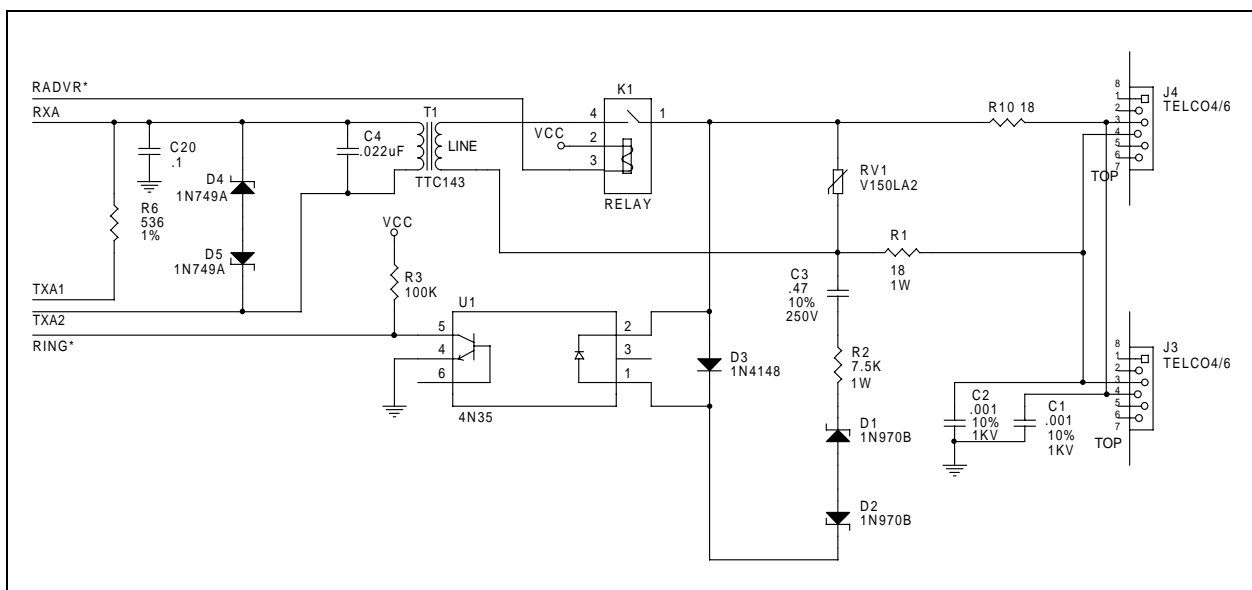

Figure 3-2. Typical DAA Interface Circuit











**WORLDWIDE**

**HEADQUARTERS**

**Rockwell Semiconductor Systems Inc.**

4311 Jamboree Road  
P.o. Box C  
Newport Beach, CA  
92658-8902  
Phone: (949) 221-4600  
Fax: (949) 221-6375

**US Northwest/Pacific Northwest**

Phone: (408) 249-9696  
Fax: (408) 249-7113

**US Southwest (Los Angeles)**

Phone: (805) 376-0559  
Fax: (805) 376-8180

**US Southwest (San Diego)**

Phone: (619) 535-3374  
Fax: (619) 452-1249

**US Southwest (Orange County)**

Phone: (949) 222-9119  
Fax: (949) 222-0620

**US North Central**

Phone: (630) 773-3454  
Fax: (630) 773-3907

**US South Central**

Phone: (972) 733-0723  
Fax: (972) 407-0639

**Strategic Sales - Compaq Rockwell Semiconductor Systems**

Phone: (281) 376-5600  
Fax: (281) 376-2468

**US Northeast**

Phone: (978) 692-7660  
Fax: (978) 692-8185

**US Southeast (Norcross, GA)**

Phone: (770) 246-8283  
Fax: (770) 246-0018

**US Southeast (Raleigh, NC)**

Phone: (919) 786-4002  
Fax: (919) 782-8727

**US Florida/South America**

Phone: (727) 799-8406  
Fax: (727) 799-8306

**US Mid-Atlantic**

Phone: (215) 244-6784  
Fax: (215) 244-9292

**Brazil**

Phone: (55-11) 3874 8978  
Fax: (55-11) 3874 8883

**European Headquarters**

Rockwell Semiconductor Systems S.A.S.  
Les Taissounieres B1  
1680 Route des Dolines  
BP 283  
06905 Sophia Antipolis Cedex,  
France  
Phone: (33) 4 93 00 33 35  
Fax: (33) 4 93 00 33 03

**Europe Central**

Phone: (49-89) 829-1320  
Fax: (49-89) 834-2734

**Europe Mediterranean**

Phone: (39 02) 93179911  
Fax: (39 02) 93179913

**Europe Mediteranean (Satellite)**

Rockwell Semiconductor Systems  
c/o Rockwell Automation S.r.l.  
Belmonta de Tajo, 31  
Phone: (34) 91 565 16 16  
Fax: (34) 91 565 16 87

**Israel**

Phone: (972-9) 9524 000  
Fax: (972-9) 9573 732

**Europe North**

Phone: (44-1344) 486 444  
Fax: (44-1344) 486 555

**Europe North (Satellite)**

Phone: (46) 8 477 4036  
Fax: (46) 8 477 4037

**Europe South**

Phone: (33-1) 49 06 39 80  
Fax: (33-1) 49 06 39 90

**APAC Headquarters**

Rockwell International Manufacturing Pte. Ltd.  
1 Kim Seng Promenade  
#09-01 East Tower  
Great World City  
Singapore 237994  
Phone: (65) 737 7355  
Fax: (65) 737 9077

**Australia**

Phone: (61-2) 9869 4088  
Fax: (61-2) 9869 4077

**China/Beijing**

Phone: (86-10) 6518-2545  
Fax: (86-10) 6518-2536

**China/Shanghai**

Phone: (86-21) 6361 2515  
Fax: (86-21) 6361 2516

**Hong Kong**

Phone: (852) 2827 0181  
Fax: (852) 2827 6488

**India**

Phone: (91-11) 6924 780  
Fax: (91-11) 6924 712

**Korea**

Phone: (82-2) 565 2880  
Fax: (82-2) 565 1440

**Taiwan Headquarters**

Rockwell International,  
Taiwan Company Limited  
Room 2808  
International Trade Building  
333, Keelung Road, Section 1  
Taipei, Taiwan, 10547 ROC  
Phone: (886-2) 2720 0282  
Fax: (886-2) 2757 6760

**Japan Headquarters**

Rockwell International  
Japan company Limited  
Shimomoto Building  
1-46-3 Hatsudai, Shibuya-ku  
Tokyo, 151 Japan  
Phone: (81-3) 5371 1520  
Fax: (81-3) 5371 1501

**Web:**  
www.rss.rockwell.com

**Email:**  
literature@rss.rockwell.com

**For more information:**  
Call 1-800-854-8099

**International Information:**  
Call 1-949-221-6996

**Document Number:**

D96V24DSA