

SN65LBC175, SN75LBC175 QUADRUPLE LOW-POWER DIFFERENTIAL LINE RECEIVERS

SLLS171D – OCTOBER 1993 – REVISED JUNE 2000

- Meets or Exceeds the EIA Standards RS-422-A, RS-423-A, RS-485, and CCITT Recommendation V.11
- Designed to Operate With Pulse Durations as Short as 20 ns
- Designed for Multipoint Transmission on Long Bus Lines in Noisy Environments
- Input Sensitivity . . . ± 200 mV
- Low-Power Consumption . . . 20 mA Max
- Open-Circuit Fail-Safe Design
- Common-Mode Input Voltage Range of -7 V to 12 V
- Pin Compatible With SN75175 and MC3486

description

The SN65LBC175 and SN75LBC175 are monolithic, quadruple, differential line receivers with 3-state outputs designed to meet the requirements of the EIA standards RS-422-A, RS-423-A, RS-485, and CCITT Recommendation V.11. The devices are optimized for balanced multipoint bus transmission at data rates up to and exceeding 10 million bits per second. The receivers are enabled in pairs, with an active-high enable input. Each differential receiver input features high impedance, hysteresis for increased noise immunity, and sensitivity of ± 200 mV over a common-mode input voltage range of 12 V to -7 V. The fail-safe design ensures that when the inputs are open-circuited, the outputs are always high. Both devices are designed using the TI proprietary LinBiCMOS™ technology allowing low power consumption, high switching speeds, and robustness.

These devices offer optimum performance when used with the SN75LBC172 or SN75LBC174 quadruple line drivers. The SN65LBC175 and SN75LBC175 are available in the 16-pin DIP (N) and small-outline inline circuit (SOIC) D packages.

The SN65LBC175 is characterized over the industrial temperature range of -40°C to 85°C . The SN75LBC175 is characterized for operation over the commercial temperature range of 0°C to 70°C .

LinBiCMOS is a trademark of Texas Instruments.

D OR N PACKAGE
(TOP VIEW)

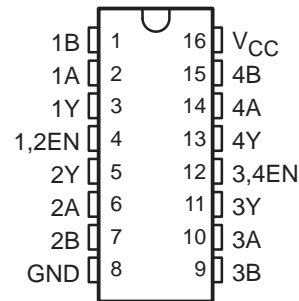

logic symbol†

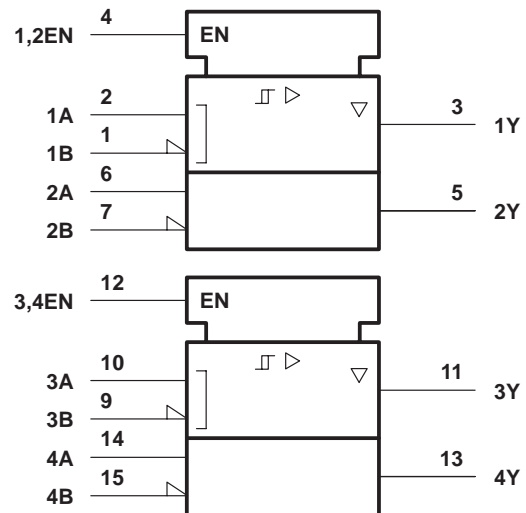

† This symbol is in accordance with ANSI/IEEE Std 91-1984 and IEC Publication 617-12.

logic diagram (positive logic)

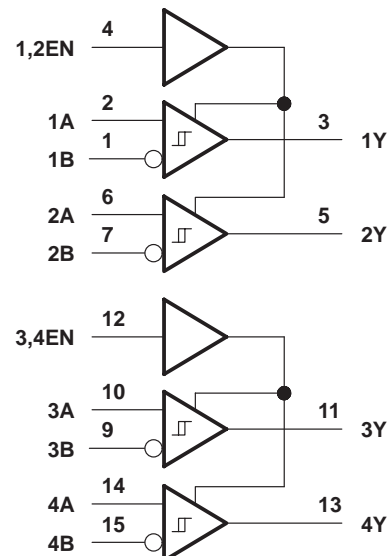

PRODUCTION DATA information is current as of publication date. Products conform to specifications per the terms of Texas Instruments standard warranty. Production processing does not necessarily include testing of all parameters.

SN65LBC175, SN75LBC175 QUADRUPLE LOW-POWER DIFFERENTIAL LINE RECEIVERS

SLLS171D – OCTOBER 1993 – REVISED JUNE 2000

FUNCTION TABLE
(each receiver)

DIFFERENTIAL INPUTS A-B	ENABLE	OUTPUT Y
$V_{ID} \geq 0.2\text{ V}$	H	H
$-0.2\text{ V} < V_{ID} < 0.2\text{ V}$	H	?
$V_{ID} \leq -0.2\text{ V}$	H	L
X	L	Z
Open circuit	H	H

H = high level, L = low level, X = irrelevant,
Z = high impedance (off), ? = indeterminate

schematics of inputs and outputs

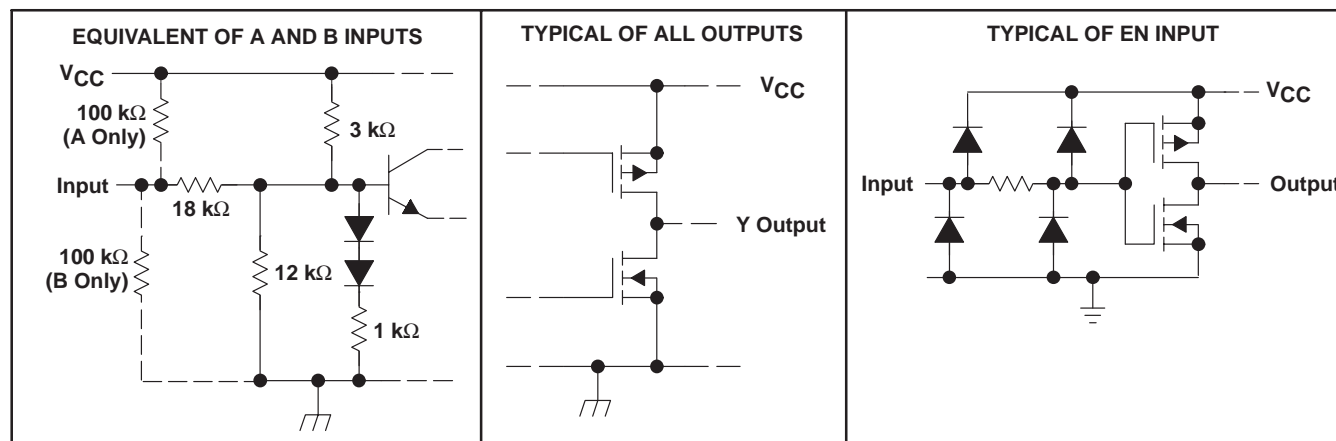

SN65LBC175, SN75LBC175 QUADRUPLE LOW-POWER DIFFERENTIAL LINE RECEIVERS

SLLS171D – OCTOBER 1993 – REVISED JUNE 2000

absolute maximum ratings over operating free-air temperature range (unless otherwise noted)†

Supply voltage range, V_{CC} (see Note 1)	–0.3 V to 7 V
Input voltage, V_I (A or B inputs)	±25 V
Differential input voltage, V_{ID} (see Note 2)	±25 V
Voltage range at Y, 1/2EN, 3/4EN	–0.3 V to $V_{CC} + 0.5$ V
Continuous total dissipation	See Dissipation Rating Table
Operating free-air temperature range, T_A : SN65LBC175	–40°C to 85°C
SN75LBC175	0°C to 70°C
Storage temperature range, T_{stg}	–65°C to 150°C
Lead temperature 1,6 mm (1/16 inch) from case for 10 seconds	260°C

† Stresses beyond those listed under “absolute maximum ratings” may cause permanent damage to the device. These are stress ratings only, and functional operation of the device at these or any other conditions beyond those indicated under “recommended operating conditions” is not implied. Exposure to absolute-maximum-rated conditions for extended periods may affect device reliability.

- NOTES: 1. All voltage values are with respect to GND.
2. Differential input voltage is measured at the noninverting input with respect to the corresponding inverting input.

DISSIPATION RATING TABLE

PACKAGE	$T_A \leq 25^\circ\text{C}$ POWER RATING	DERATING FACTOR ABOVE $T_A = 25^\circ\text{C}$	$T_A = 70^\circ\text{C}$ POWER RATING	$T_A = 85^\circ\text{C}$ POWER RATING
D	1100 mW	8.7 mW/°C	709 mW	578 mW
N	1150 mW	9.2 mW/°C	736 mW	598 mW

recommended operating conditions

	MIN	NOM	MAX	UNIT
Supply voltage, V_{CC}	4.75	5	5.25	V
Common-mode input voltage, V_{IC}	–7		12	V
Differential input voltage, V_{ID}			±6	V
High-level input voltage, V_{IH}	EN inputs		2	V
Low-level input voltage, V_{IL}			0.8	V
High-level output current, I_{OH}			–8	mA
Low-level output current, I_{OL}			16	mA
Operating free-air temperature, T_A	SN65LBC175		–40	85
	SN75LBC175		0	70
				°C

SN65LBC175, SN75LBC175 QUADRUPLE LOW-POWER DIFFERENTIAL LINE RECEIVERS

SLLS171D – OCTOBER 1993 – REVISED JUNE 2000

electrical characteristics over recommended ranges of supply voltage and operating free-air temperature (unless otherwise noted)

PARAMETER		TEST CONDITIONS	MIN	TYP†	MAX	UNIT
V_{IT+}	Positive-going input threshold voltage	$I_O = -8 \text{ mA}$			0.2	V
V_{IT-}	Negative-going input threshold voltage	$I_O = 8 \text{ mA}$	-0.2			V
V_{hys}	Hysteresis voltage ($V_{IT+} - V_{IT-}$)			45		mV
V_{IK}	Enable input clamp voltage	$I_I = -18 \text{ mA}$	-0.9	-1.5		V
V_{OH}	High-level output voltage	$V_{ID} = 200 \text{ mV}$, $I_{OH} = -8 \text{ mA}$	3.5	4.5		V
V_{OL}	Low-level output voltage	$V_{ID} = -200 \text{ mV}$, $I_{OL} = 8 \text{ mA}$		0.3	0.5	V
I_{OZ}	High-impedance-state output current	$V_O = 0 \text{ V to } V_{CC}$			± 20	μA
I_I	Bus input current	A or B inputs	$V_{IH} = 12 \text{ V}$, $V_{CC} = 5 \text{ V}$, Other inputs at 0 V	0.7	1	mA
			$V_{IH} = 12 \text{ V}$, $V_{CC} = 0 \text{ V}$, Other inputs at 0 V	0.8	1	mA
			$V_{IH} = -7 \text{ V}$, $V_{CC} = 5 \text{ V}$, Other inputs at 0 V	-0.5	-0.8	mA
			$V_{IH} = -7 \text{ V}$, $V_{CC} = 0 \text{ V}$, Other inputs at 0 V	-0.4	-0.8	mA
I_{IH}	High-level enable input current	$V_{IH} = 5 \text{ V}$			± 20	μA
I_{IL}	Low-level enable input current	$V_{IL} = 0 \text{ V}$			-20	μA
I_{OS}	Short-circuit output current	$V_O = 0$	-80	-120		mA
I_{CC}	Supply current	Outputs enabled, $I_O = 0$, $V_{ID} = 5 \text{ V}$		11	20	mA
		Outputs disabled	0.9	1.4		

† All typical values are at $V_{CC} = 5 \text{ V}$ and $T_A = 25^\circ\text{C}$.

switching characteristics, $V_{CC} = 5 \text{ V}$, $C_L = 15 \text{ pF}$, $T_A = 25^\circ\text{C}$

PARAMETER		TEST CONDITIONS	MIN	TYP†	MAX	UNIT
t_{PHL}	Propagation delay time, high- to low-level output	$V_{ID} = -1.5 \text{ V to } 1.5 \text{ V}$,	11	22	30	ns
t_{PLH}	Propagation delay time, low- to high-level output	See Figure 1	11	22	30	
t_{PZH}	Output enable time to high level	See Figure 2		17	30	ns
t_{PZL}	Output enable time to low level	See Figure 3		18	30	ns
t_{PHZ}	Output disable time from high level	See Figure 2		30	40	ns
t_{PLZ}	Output disable time from low level	See Figure 3		23	30	ns
$t_{sk(p)}$	Pulse skew ($ t_{PHL} - t_{PLH} $)	See Figure 2		4	6	ns
t_t	Transition time	See Figure 1		3	10	ns



SN65LBC175, SN75LBC175 QUADRUPLE LOW-POWER DIFFERENTIAL LINE RECEIVERS

SLLS171D – OCTOBER 1993 – REVISED JUNE 2000

PARAMETER MEASUREMENT INFORMATION

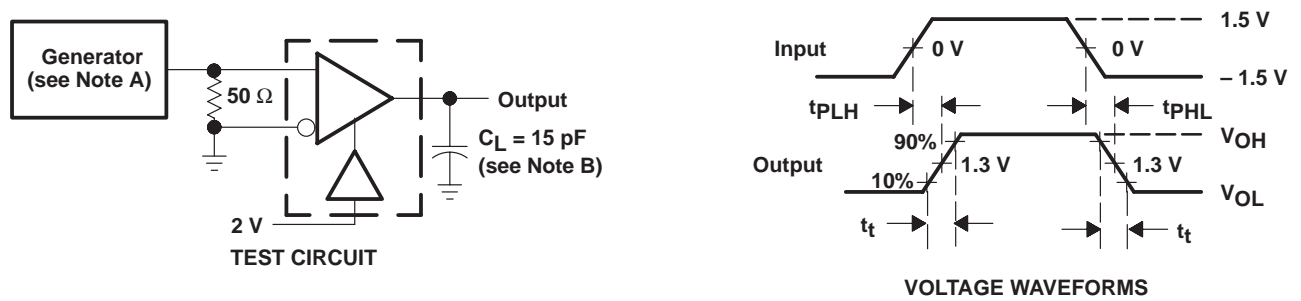
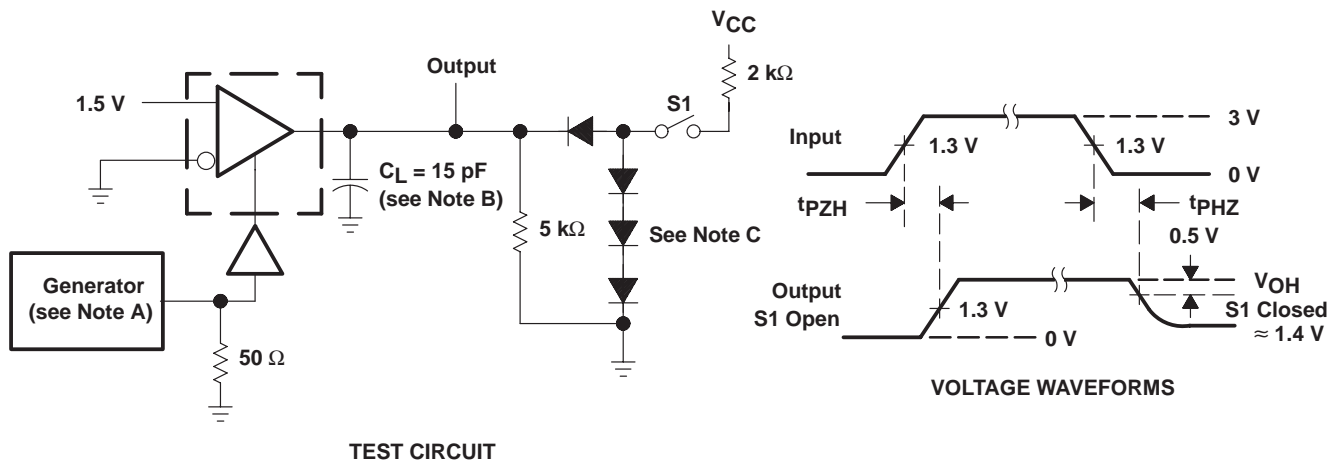

Figure 1. t_{pLH} and t_{pHL} Test Circuit and Voltage Waveforms



- NOTES: A. The input pulse is supplied by a generator having the following characteristics: PRR = 1 MHz, duty cycle = 50%, $t_r \leq 6$ ns, $t_f \leq 6$ ns, $Z_O = 50 \Omega$.
 B. C_L includes probe and jig capacitance.
 C. All diodes are 1N916 or equivalent.

Figure 2. t_{pHZ} and t_{pZH} Test Circuit and Voltage Waveforms

SN65LBC175, SN75LBC175 QUADRUPLE LOW-POWER DIFFERENTIAL LINE RECEIVERS

SLLS171D – OCTOBER 1993 – REVISED JUNE 2000

PARAMETER MEASUREMENT INFORMATION

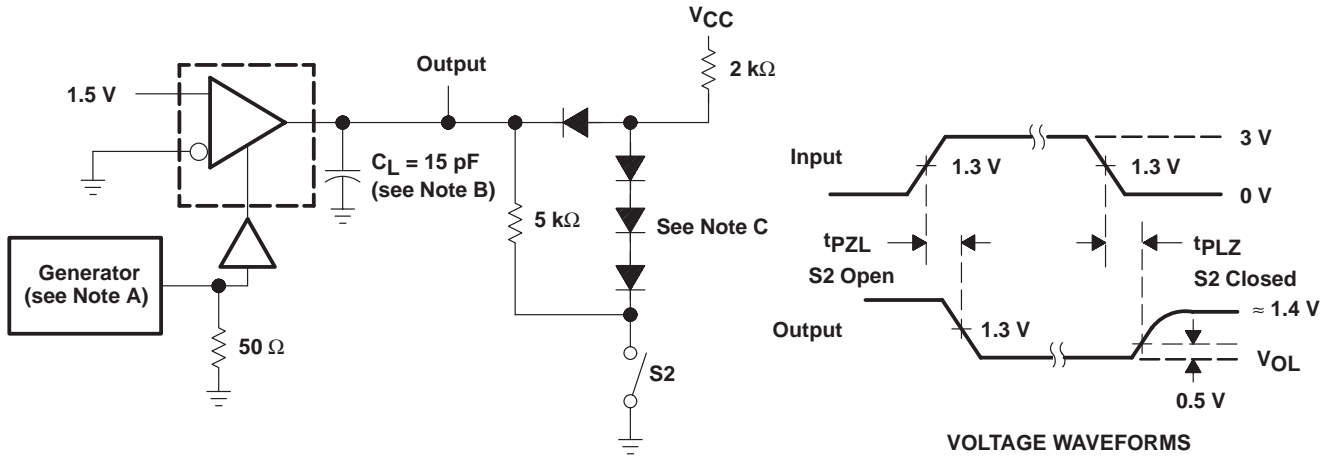

TEST CIRCUIT

- NOTES: A. The input pulse is supplied by a generator having the following characteristics: PRR = 1 MHz, duty cycle = 50%, $t_r \leq 6$ ns, $t_f \leq 6$ ns, $Z_O = 50 \Omega$.
 B. C_L includes probe and jig capacitance.
 C. All diodes are 1N916 or equivalent.

Figure 3. t_{pZL} and t_{PLZ} Test Circuit and Voltage Waveforms

TYPICAL CHARACTERISTICS

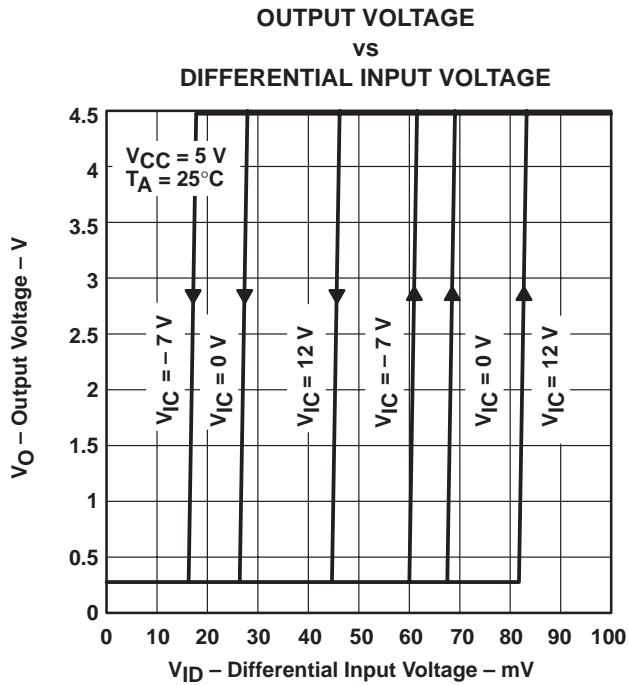

Figure 4

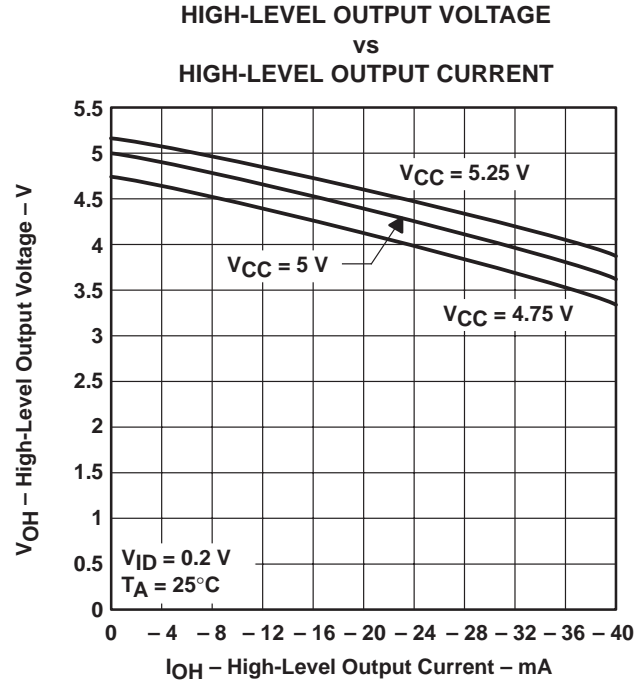

Figure 5

SN65LBC175, SN75LBC175 QUADRUPLE LOW-POWER DIFFERENTIAL LINE RECEIVERS

SLLS171D – OCTOBER 1993 – REVISED JUNE 2000

TYPICAL CHARACTERISTICS

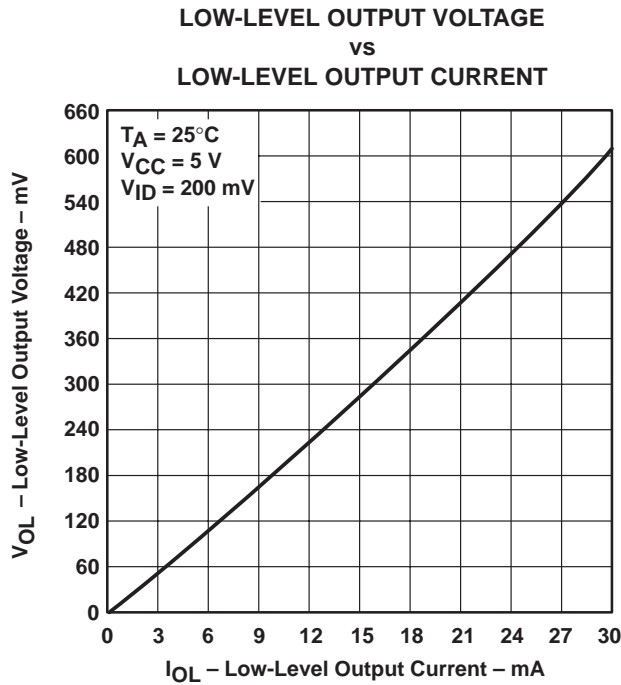

Figure 6

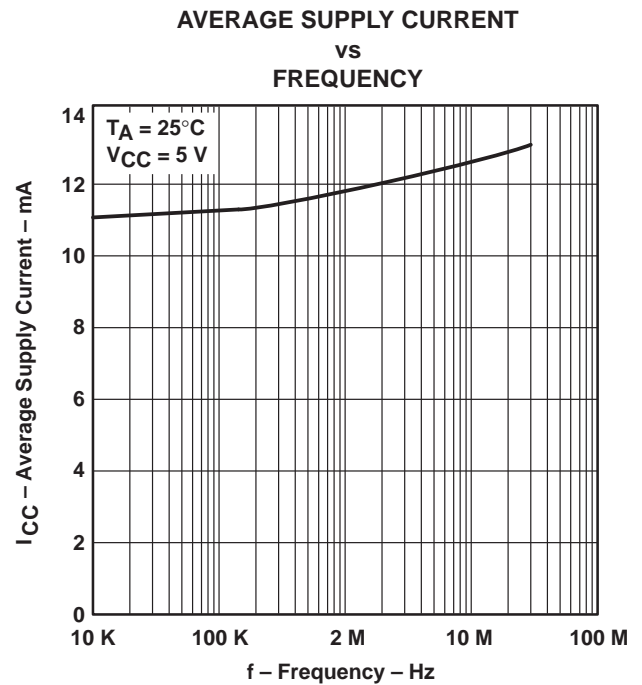

Figure 7

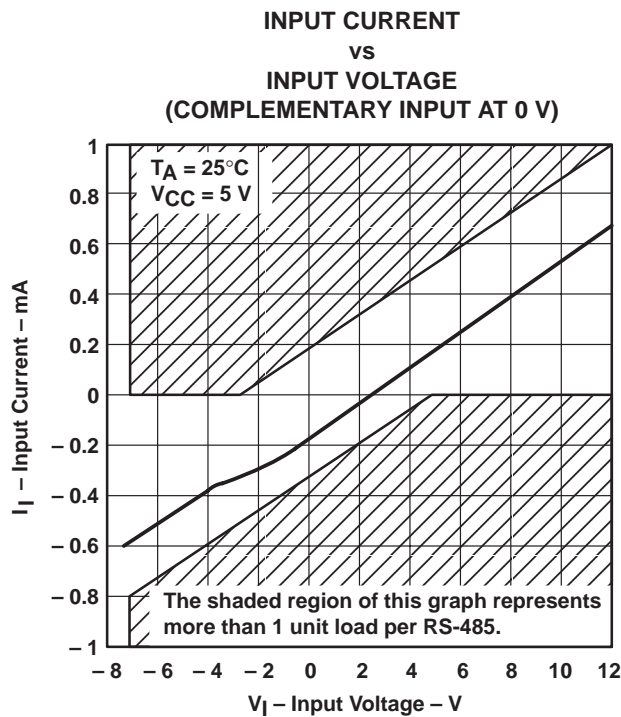

Figure 8

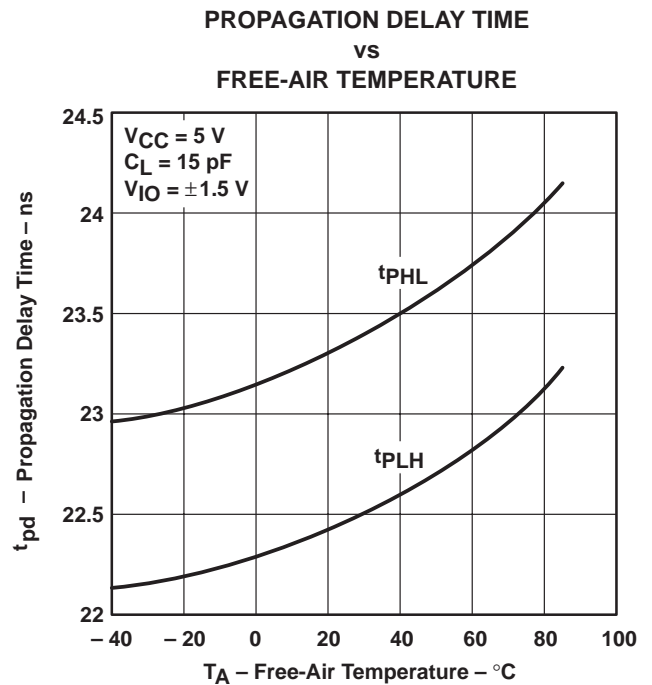

Figure 9

SN65LBC175, SN75LBC175 QUADRUPLE LOW-POWER DIFFERENTIAL LINE RECEIVERS

SLLS171D – OCTOBER 1993 – REVISED JUNE 2000

MECHANICAL DATA

D (R-PDSO-G**)

PLASTIC SMALL-OUTLINE PACKAGE

14 PIN SHOWN

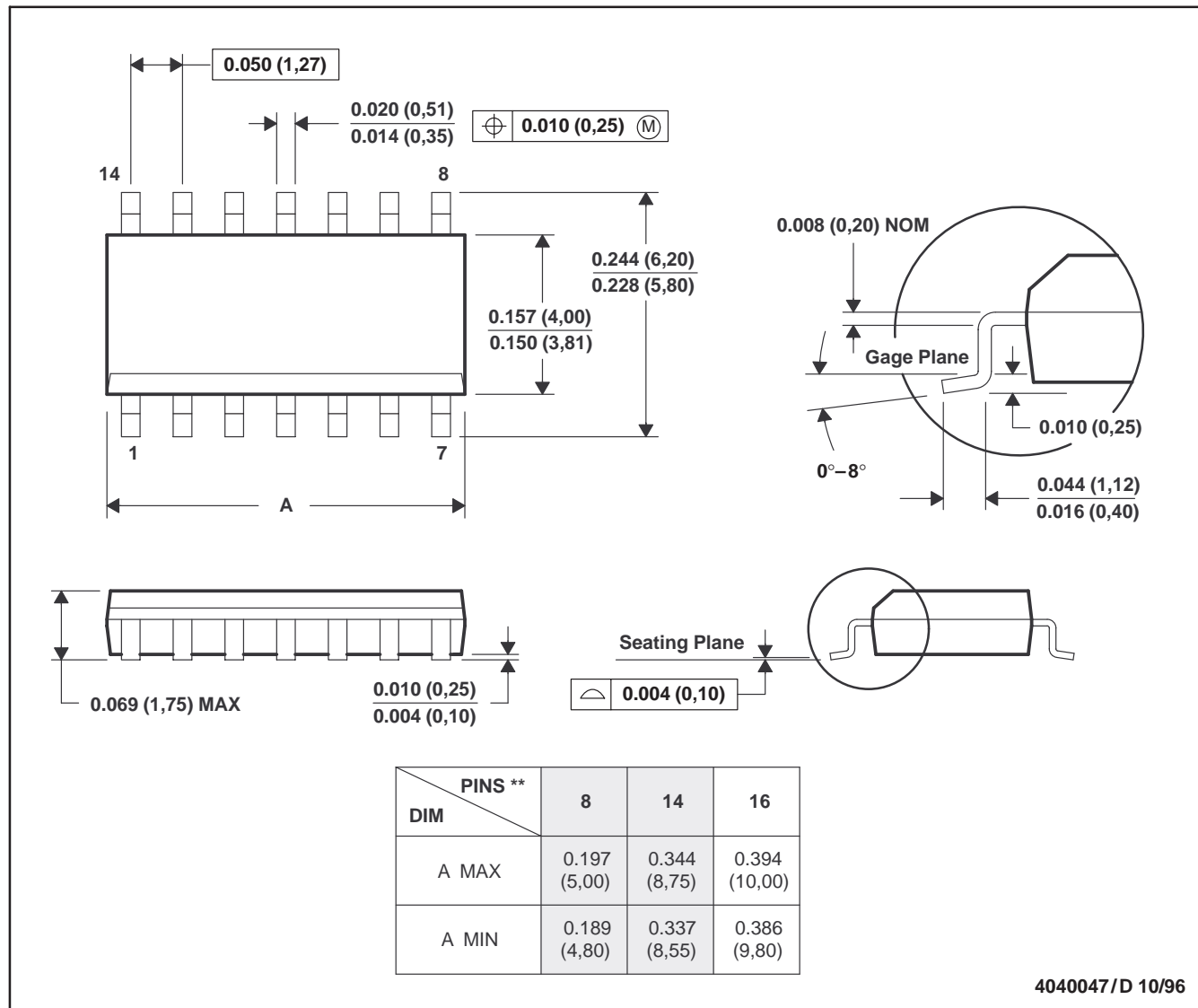

- NOTES: A. All linear dimensions are in inches (millimeters).
 B. This drawing is subject to change without notice.
 C. Body dimensions do not include mold flash or protrusion, not to exceed 0.006 (0,15).
 D. Falls within JEDEC MS-012

SN65LBC175, SN75LBC175 QUADRUPLE LOW-POWER DIFFERENTIAL LINE RECEIVERS

SLLS171D – OCTOBER 1993 – REVISED JUNE 2000

MECHANICAL DATA

N (R-PDIP-T)**

PLASTIC DUAL-IN-LINE PACKAGE

16 PIN SHOWN

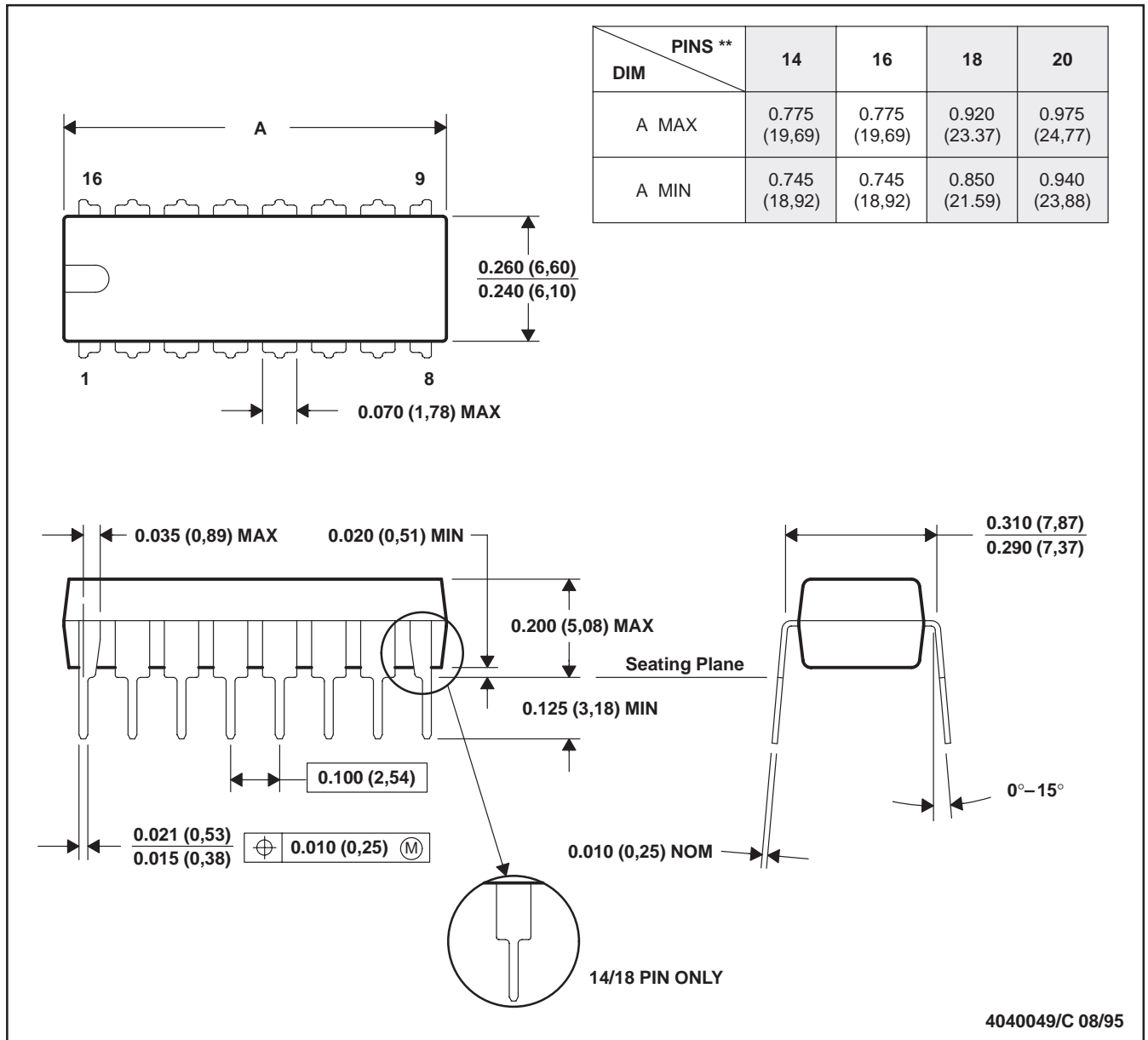

- NOTES: A. All linear dimensions are in inches (millimeters).
 B. This drawing is subject to change without notice.
 C. Falls within JEDEC MS-001 (20 pin package is shorter than MS-001.)

IMPORTANT NOTICE

Texas Instruments and its subsidiaries (TI) reserve the right to make changes to their products or to discontinue any product or service without notice, and advise customers to obtain the latest version of relevant information to verify, before placing orders, that information being relied on is current and complete. All products are sold subject to the terms and conditions of sale supplied at the time of order acknowledgment, including those pertaining to warranty, patent infringement, and limitation of liability.

TI warrants performance of its semiconductor products to the specifications applicable at the time of sale in accordance with TI's standard warranty. Testing and other quality control techniques are utilized to the extent TI deems necessary to support this warranty. Specific testing of all parameters of each device is not necessarily performed, except those mandated by government requirements.

Customers are responsible for their applications using TI components.

In order to minimize risks associated with the customer's applications, adequate design and operating safeguards must be provided by the customer to minimize inherent or procedural hazards.

TI assumes no liability for applications assistance or customer product design. TI does not warrant or represent that any license, either express or implied, is granted under any patent right, copyright, mask work right, or other intellectual property right of TI covering or relating to any combination, machine, or process in which such semiconductor products or services might be or are used. TI's publication of information regarding any third party's products or services does not constitute TI's approval, warranty or endorsement thereof.