

1.9GHz BAND FRONT-END GaAs MMIC

GENERAL DESCRIPTION

NJG1714KC1 is a front-end GaAs MMIC including a LNA, a local amplifier and a mixer, designed mainly for 1.9GHz band cellular phone handsets.

The external adjustment circuit is built into NJG1714KC1.

The ultra small & ultra thin FLP10 package is applied.

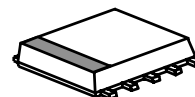
PACKAGE OUTLINE

NJG1714KC1

FEATURES

- Low Voltage Operation +2.7V typ.
- Low Current Consumption LNA 2.8mA typ.
Mixer 5.0mA typ. (with Local Amplifier operation current)
- Ultra Small & Ultra Thin package FLP10-C1 (Mount Size: 2.8 x 3.0 x 0.75mm)

[LNA]

- High Small Signal Gain 15.0dB typ. @ $f_{RF}=1900\text{MHz}$
- Low Noise Figure 1.3dB typ. @ $f_{RF}=1900\text{MHz}$
- OIP3 +13.0dBm typ. @ $f_{RF}=1900.0+1900.1\text{MHz}$

[Mixer]

- High Conversion Gain 9.0dB typ. @ $f_{RF}=1900\text{MHz}$, $f_{LO}=1660\text{MHz}$, $P_{LO}=-15\text{dBm}$
- Low Noise Figure 7.0dB typ. @ $f_{RF}=1900\text{MHz}$, $f_{LO}=1660\text{MHz}$, $P_{LO}=-15\text{dBm}$
- OIP3 +11.0dBm typ. @ $f_{RF}=1900.0+1900.1\text{MHz}$, $f_{LO}=1660\text{MHz}$, $P_{LO}=-15\text{dBm}$

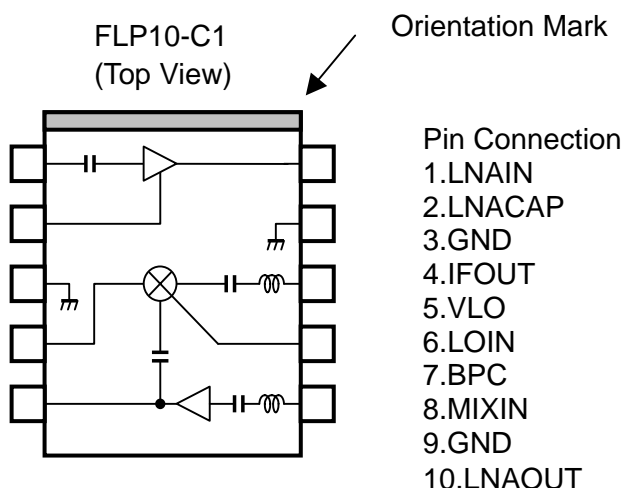
PIN CONFIGURATION

NOTE: Please note that any information on this catalog will be subject to change.

NJG1714KC1

■ABSOLUTE MAXIMUM RATINGS

($T_a=+25^{\circ}\text{C}$, $Z_s=Z_l=50\Omega$)

PARAMETER	SYMBPL	CONDITIONS	RATINGS	UNITS
LNA Voltage	V_{LNA}		5.0	V
Mixer Voltage	V_{MIX}		5.0	V
Local Amplifier Voltage	V_{LO}		5.0	V
Input Power 1	P_{LNAIN}	$V_{LNA}=V_{MIX}=V_{LO}=2.7\text{V}$	+15	dBm
Input Power 2	P_{LOIN}	$V_{LNA}=V_{MIX}=V_{LO}=2.7\text{V}$	+10	dBm
Power Dissipation	P_D		550	mW
Operating Temperature	T_{opr}		-40~+85	$^{\circ}\text{C}$
Storage Temperature	T_{stg}		-55~+125	$^{\circ}\text{C}$

■ELECTRICAL CHARACTERISTICS 1 (LNA)

GENERAL CONDITIONS: $T_a=+25^{\circ}\text{C}$, $V_{LNA}=2.7\text{V}$, $V_{MIX}=V_{LO}=0\text{V}$, $f_{RF}=1900\text{MHz}$, $P_{RF}=-36\text{dBm}$, $Z_s=Z_l=50\Omega$, with test circuit

PARAMETER	SYMBOL	CONDITIONS	MIN	TYP	MAX	UNITS
Operating Frequency	freq		1890	1900	1920	MHz
LNA Voltage	V_{LNA}		2.5	2.7	4.5	V
LNA Operating Current	I_{LNA}	$P_{RF}, P_{LO}=\text{OFF}$	-	2.8	3.5	mA
Small Signal Gain	Gain		13.0	15.0	-	dB
Gain Flatness	G_{flat}	$f_{RF}=1890\sim 1920\text{MHz}$	-	0.5	1.0	dB
Noise Figure	NF		-	1.3	1.5	dB
Pout at 1dB Gain Compression point	P_{-1dB}		-4.0	0	-	dBm
Output 3rd order Intercept point	OIP3	$f_{RF}=1900.0+1900.1\text{MHz}$	+9.0	+13.0	-	dBm
RF IN VSWR	$VSWR_i$		-	2.0	-	
RF OUT VSWR	$VSWR_o$		-	2.0	-	

■ELECTRICAL CHARACTERISTICS 2 (Mixer)

GENERAL CONDITIONS: $T_a=+25^{\circ}\text{C}$, $V_{LNA}=0\text{V}$, $V_{MIX}=V_{LO}=2.7\text{V}$, $f_{RF}=1900\text{MHz}$, $f_{LO}=1660\text{MHz}$, $P_{RF}=-30\text{dBm}$, $P_{LO}=-15\text{dBm}$, $Z_s=Z_l=50\Omega$, with test circuit

PARAMETER	SYMBOL	CONDITIONS	MIN	TYP	MAX	UNITS
Operating Frequency	freq		1890	1900	1920	MHz
Mixer Voltage	V_{MIX}		2.5	2.7	4.5	V
Local Amplifier Voltage	V_{LO}		2.5	2.7	4.5	V
Mixer Operating Current	I_{MIX}	$P_{RF}, P_{LO}=\text{OFF}$	-	4.6	5.7	mA
Local Amplifier Operating Current	I_{LO}	$P_{RF}, P_{LO}=\text{OFF}$	-	0.9	1.3	mA
Conversion Gain	G_c		7.0	9.0	-	dB
Noise Figure	NF		-	7.0	9.0	dB
Output 3rd Order Intercept Point	OIP3	$f_{RF}=1900.0+1900.1\text{MHz}$	+7.0	+11.0	-	dBm
MIXER IN VSWR	$VSWR_M$		-	2.0	-	
LOCAL IN VSWR	$VSWR_L$		-	2.0	-	
IF OUT VSWR	$VSWR_i$		-	1.5	-	

■ TERMINAL INFORMATION

No.	SYMBOL	FUNCTION
1	LNAIN	RF input terminal of LNA. An external matching circuit is required.
2	LNACAP	Terminal for the bypass capacitor of LNA. The bypass capacitor C1 shown in test circuits should be connected to this terminal as close as possible.
3	GND	Ground terminal (0V)
4	IFOUT	IF signal output terminal. The IF signal is output through external matching circuit connected to this terminal. Please connect inductances L7, L8 and power supply as shown in test circuits, since this terminal is also the terminal of mixer power supply.
5	VLO	Power supply terminal for local amplifier. Please place L6 shown in test circuits at very close to this terminal.
6	LOIN	Local signal input terminal to local amplifier. An external matching circuit is required.
7	BPC	Terminal for the bypass capacitor of mixer. The bypass capacitor C4 shown in test circuits should be connected to this terminal as close as possible.
8	MIXIN	RF signal input terminal to mixer. An external matching circuit is required.
9	GND	Ground terminal (0V)
10	LNAOUT	Signal output terminal of LNA. The RF signal from LNA goes out through external matching circuit connected to this terminal. Please connect inductances L3, L4 and power supply as shown in test circuits, since this terminal is also the terminal of LNA power supply.

CAUTION

- 1) Ground terminal (No.3, 9) should be connected to the ground plane as close as possible.

NJG1714KC1

TYPICAL CHARACTERISTICS 1 (LNA, f=1.9GHz, with test circuit)

Gain, Noise Figure vs. Frequency

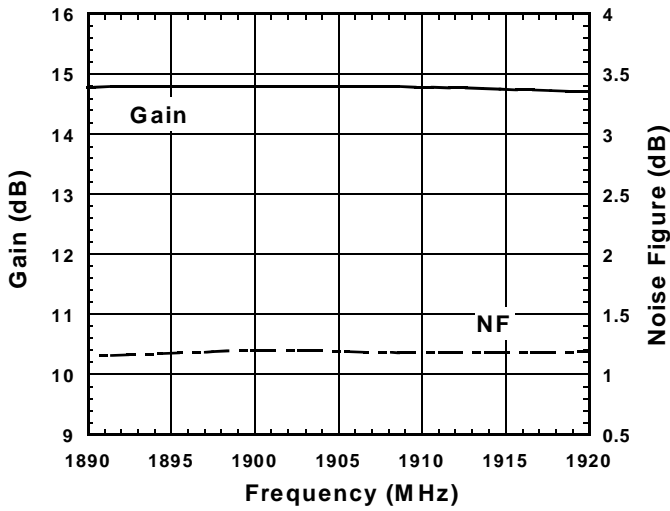

Condition
 f=1890~1920MHz
 $V_{LNA}=2.7V$
 $V_{MIX}=V_{LO}=0V$

Output Power vs. Input Power

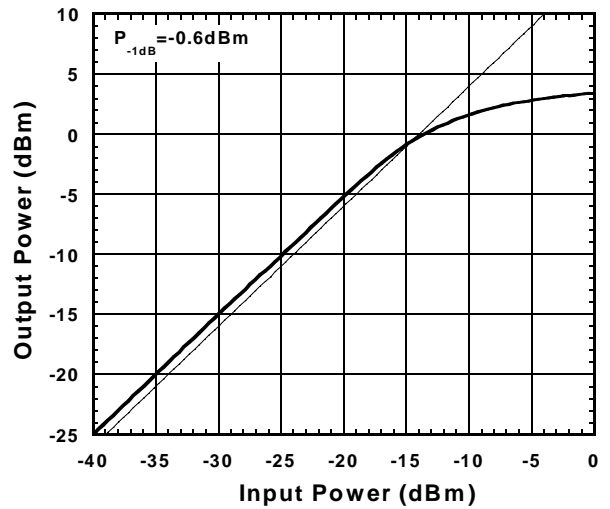

Condition
 f=1900MHz
 $V_{LNA}=2.7V$
 $V_{MIX}=V_{LO}=0V$

OIP3, IIP3 vs. Frequency

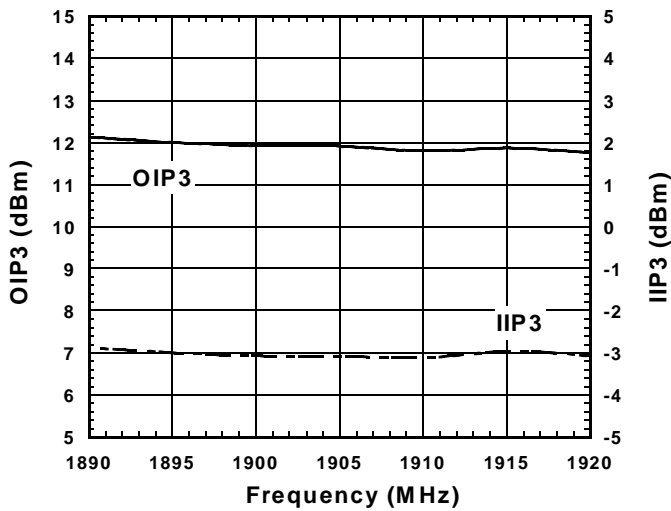

Condition
 f=1890~1920MHz
 $f_{OFFSET}=100kHz$
 $P_{in}=-36dBm$
 $V_{LNA}=2.7V$
 $V_{MIX}=V_{LO}=0V$

Output Power, IM3 vs. Input Power

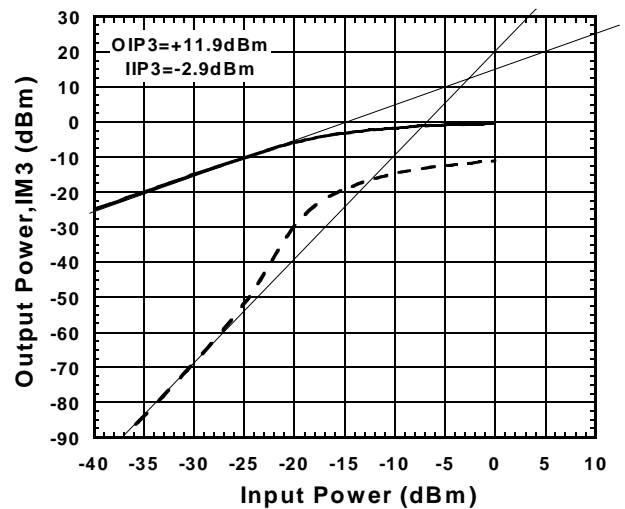

Condition
 f=1900.0+1900.1MHz
 $V_{LNA}=2.7V$
 $V_{MIX}=V_{LO}=0V$

The value of OIP3 and IIP3 shown in typical characteristics are calculated

$$OIP3 = \frac{3 \times P_{out} - IM3}{2}$$

$$IIP3 = OIP3 - Gain$$

@ $P_{in} = -36dBm$

TYPICAL CHARACTERISTICS 1 (LNA, f=1.9GHz, with test circuit)

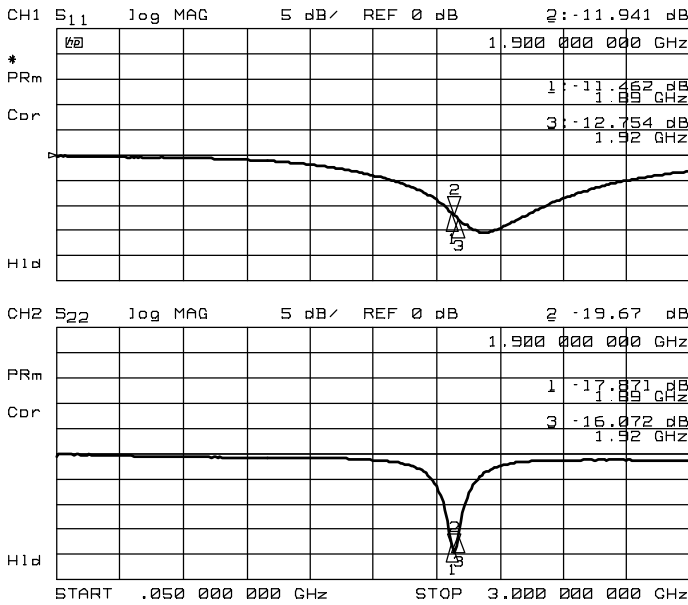

S₁₁ and S₂₂
Condition
V_{LNA}=2.7V
V_{MIX}=V_{LO}=0V

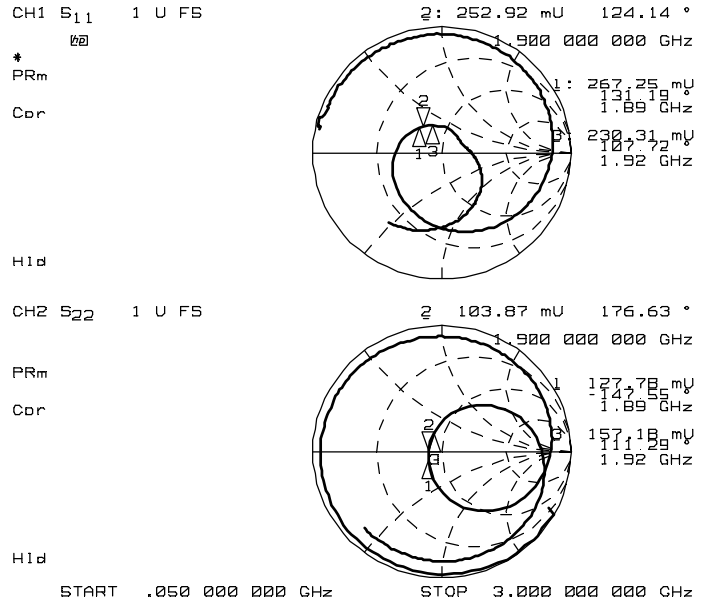

Z₁₁ and Z₂₂
Condition
V_{LNA}=2.7V
V_{MIX}=V_{LO}=0V

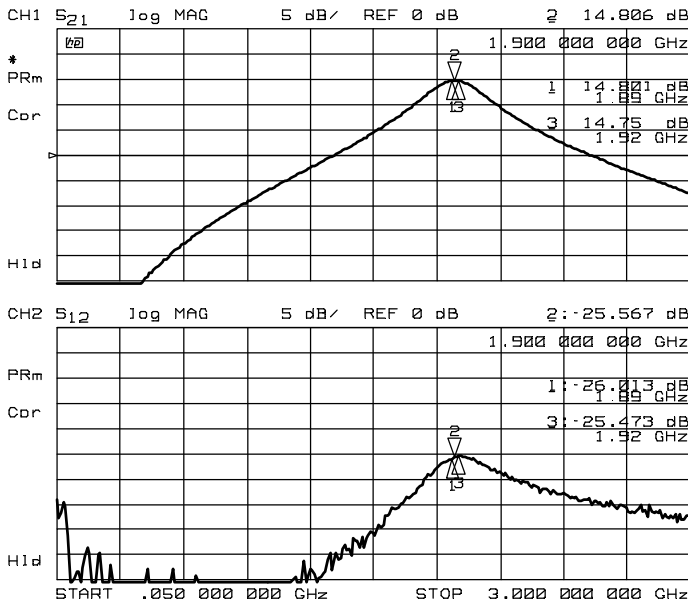

S₂₁ and S₁₂
Condition
V_{LNA}=2.7V
V_{MIX}=V_{LO}=0V

NJG1714KC1

■ TYPICAL CHARACTERISTICS 1 (LNA, f=1.9GHz, with test circuit)

Gain, Noise Figure vs. V_{LNA}

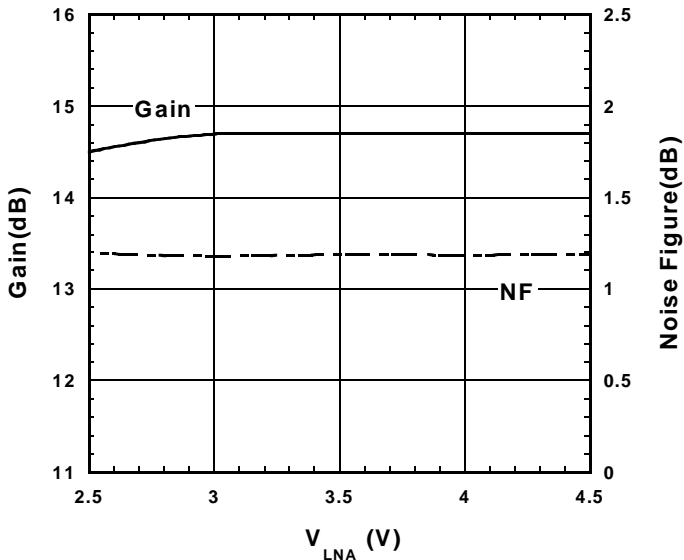

Condition
 $f=1900\text{MHz}$, $P_{in}=-36\text{dBm}$
 $V_{LNA}=2.5\sim 4.5\text{V}$
 $V_{MIX}=V_{LO}=0\text{V}$

OIP3, IIP3 vs. V_{LNA}

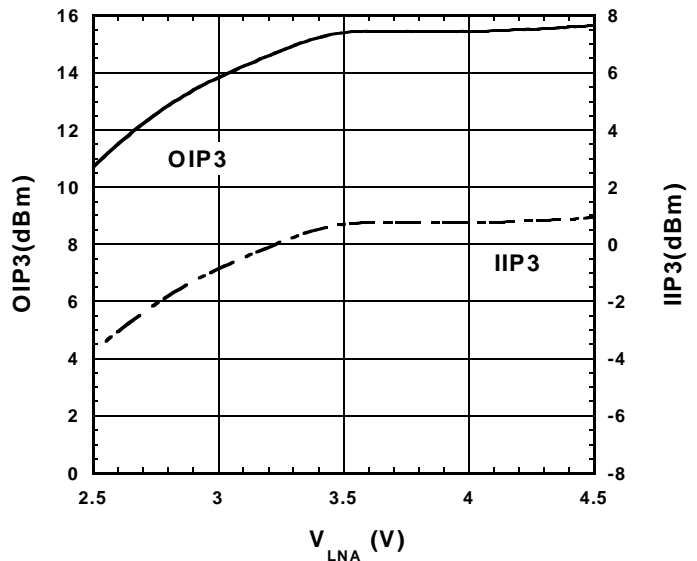

Condition
 $f=1900+1900.1\text{MHz}$
 $P_{in}=-36\text{dBm}$
 $V_{LNA}=2.5\sim 4.5\text{V}$
 $V_{MIX}=V_{LO}=0\text{V}$

P-1dB, I_{LNA} vs. V_{LNA}

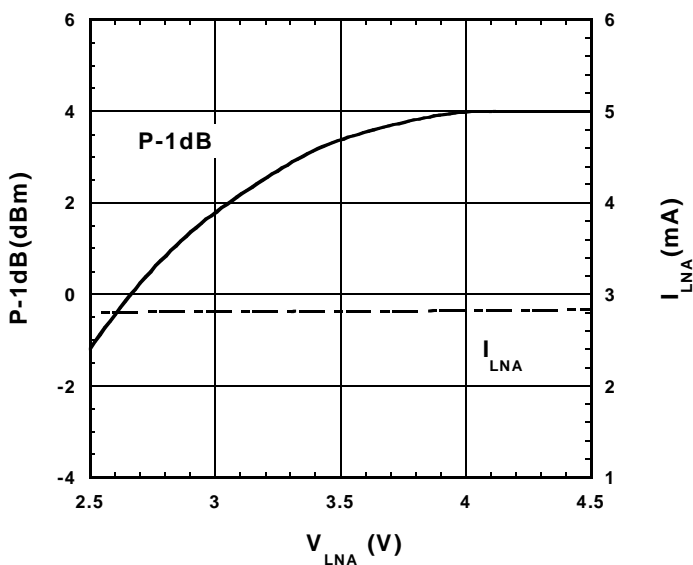

Condition
 $f=1900\text{MHz}$
 $V_{LNA}=2.5\sim 4.5\text{V}$
 $V_{MIX}=V_{LO}=0\text{V}$

The value of OIP3 and IIP3 shown in typical characteristics are calculated

$$OIP3 = \frac{3 \times P_{out} - IM3}{2}$$

$$IIP3 = OIP3 - \text{Gain}$$

@ $P_{in} = -36\text{dBm}$

TYPICAL CHARACTERISTICS 1 (LNA, f=1.9GHz, with test circuit)

Gain, Noise Figure vs. Temperature

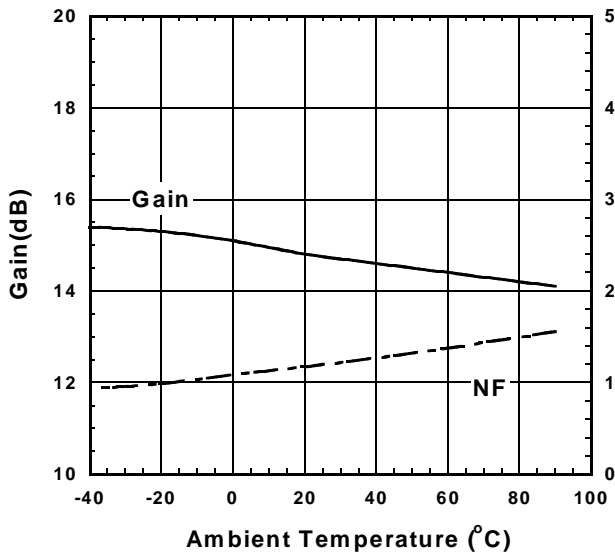

Condition
 f=1900MHz
 $V_{LNA}=2.7V$
 $V_{MIX}=V_{LO}=0V$

OIP3, IIP3 vs. Temperature

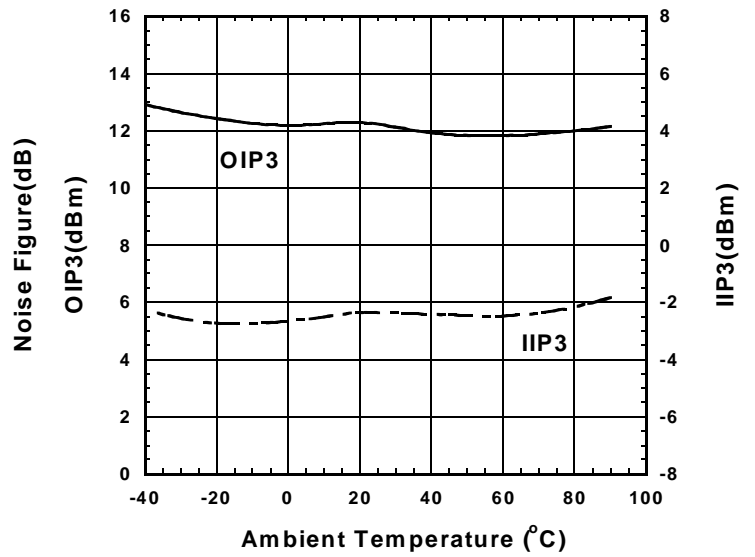

Condition
 f=1900+1900.1MHz
 $P_{in}=-36dBm$
 $V_{LNA}=2.7V$
 $V_{MIX}=V_{LO}=0V$

P-1dB, I_{LNA} vs. Temperature

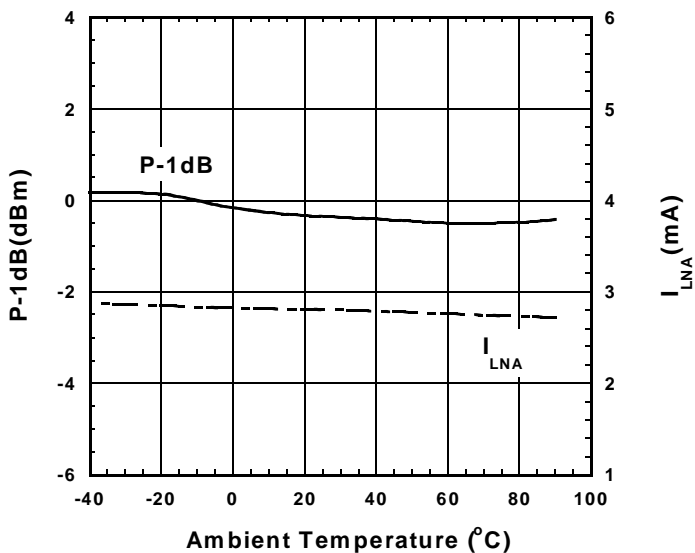

Condition
 f=1900MHz
 $V_{LNA}=2.7V$
 $V_{MIX}=V_{LO}=0V$

The value of OIP3 and IIP3 shown in typical characteristics are calculated

$$OIP3 = \frac{3 \times P_{out} - IM3}{2}$$

$$IIP3 = OIP3 - Gain$$

@ $P_{in} = -36dBm$

NJG1714KC1

TYPICAL CHARACTERISTICS 2 (MIXER, f=1.9GHz, f_{LO}=1660MHz, with test circuit)

Conversion Gain, Noise Figure vs. RF Frequency

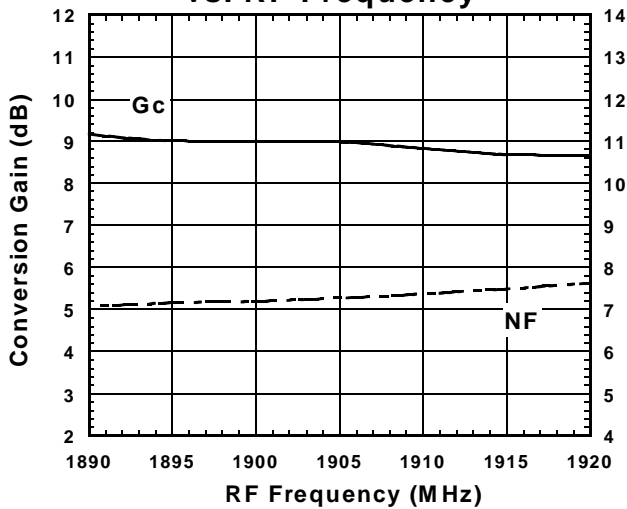

Condition
 f_{IF}=240MHz
 f_{RF}=1890~1920MHz, P_{RF}=-30dBm
 Lower LOCAL, P_{LO}=-15dBm
 V_{LNA}=0V
 V_{MIX}=V_{LO}=2.7V

Conversion Gain, Noise Figure vs. LO Power

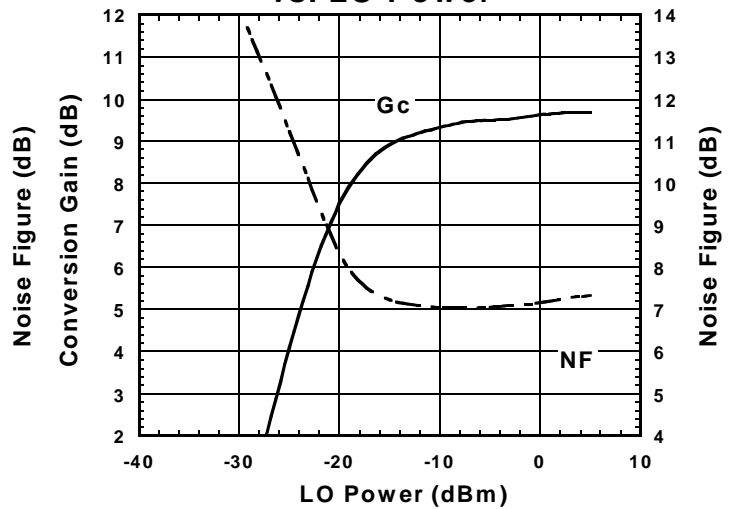

Condition
 f_{IF}=240MHz
 f_{RF}=1900MHz, P_{RF}=-30dBm
 f_{LO}=1660MHz
 V_{LNA}=0V
 V_{MIX}=V_{LO}=2.7V

OIP3, IIP3 vs. RF Frequency

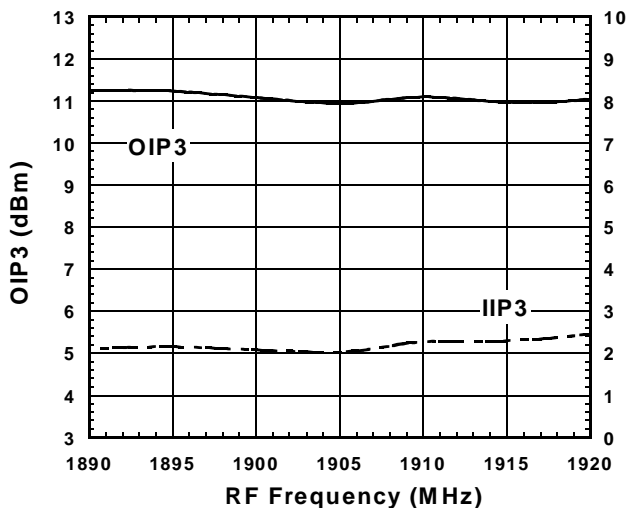

Condition
 f_{IF}=240MHz
 f_{RF}=1890~1920MHz, P_{RF}=-30dBm
 f_{RF OFFSET}=100kHz
 Lower LOCAL, P_{LO}=-15dBm
 V_{LNA}=0V
 V_{MIX}=V_{LO}=2.7V

OIP3, IIP3 vs. LO Power

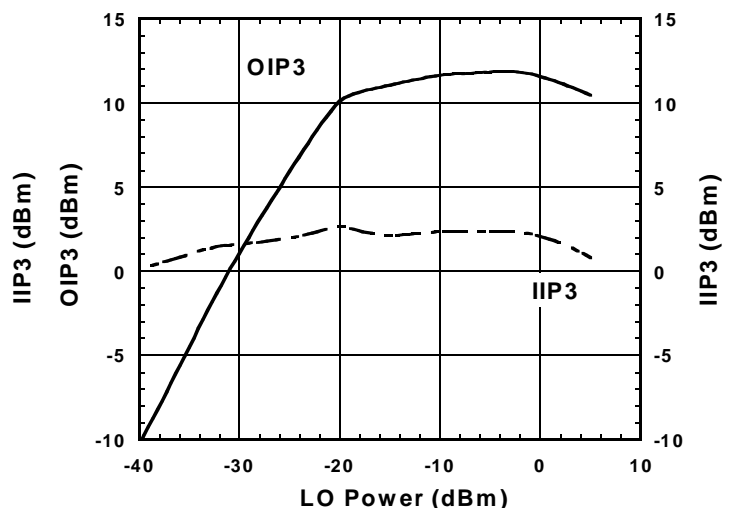

Condition
 f_{IF}=240MHz
 f_{RF}=1900.0+1900.1MHz, P_{RF}=-30dBm
 f_{LO}=1660MHz
 V_{LNA}=0V
 V_{MIX}=V_{LO}=2.7V

The value of OIP3 and IIP3 shown in typical characteristics are calculated

$$OIP3 = \frac{3 \times P_{out} - 1M3}{2}$$

$$IIP3 = OIP3 - \text{Gain}$$

@Pin=-30dBm

TYPICAL CHARACTERISTICS 2 (MIXER, $f=1.9\text{GHz}$, $f_{LO}=1660\text{MHz}$, with test circuit)

IF Output Power vs. RF Power

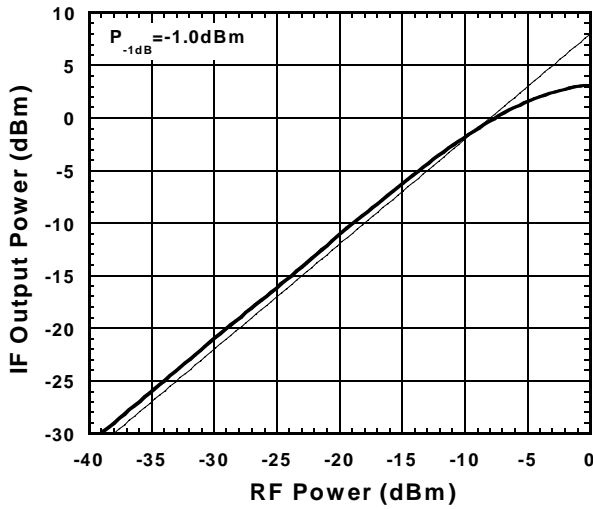

Condition
 $f_{IF}=240\text{MHz}$
 $f_{RF}=1900\text{MHz}$
 $f_{LO}=1660\text{MHz}, P_{LO}=-15\text{dBm}$
 $V_{LNA}=0\text{V}$
 $V_{MIX}=V_{LO}=2.7\text{V}$

IF, IM3 vs. RF Power

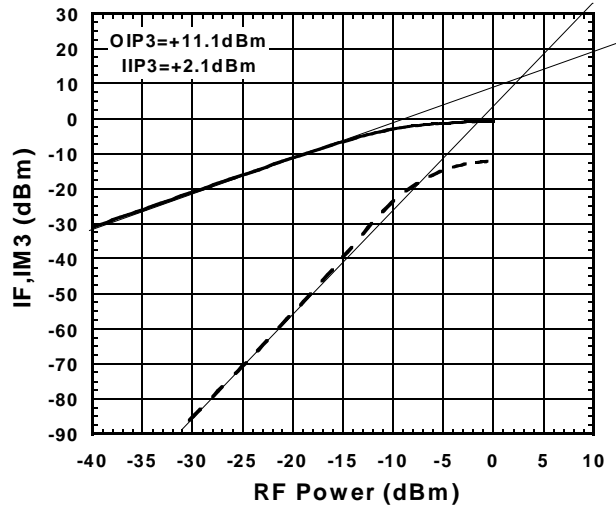

Condition
 $f_{IF}=240\text{MHz}$
 $f_{RF}=1900.0+1900.1\text{MHz}$
 $f_{LO}=1660\text{MHz}, P_{LO}=-15\text{dBm}$
 $V_{LNA}=0\text{V}$
 $V_{MIX}=V_{LO}=2.7\text{V}$

LO Leakage vs. LO Frequency

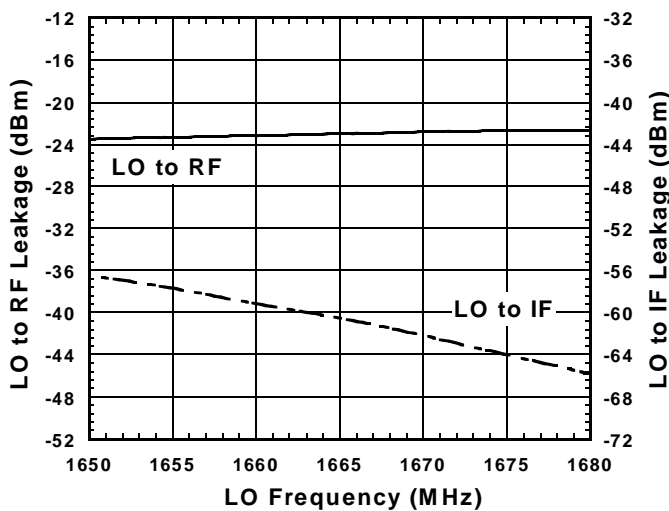

Condition
 $f_{LO}=1650\sim 1680\text{MHz}, P_{LO}=-15\text{dBm}$
 $V_{LNA}=0\text{V}$
 $V_{MIX}=V_{LO}=2.7\text{V}$

NJG1714KC1

■ TYPICAL CHARACTERISTICS 2 (MIXER, $f=1.9\text{GHz}$, $f_{LO}=1660\text{MHz}$, with test circuit)

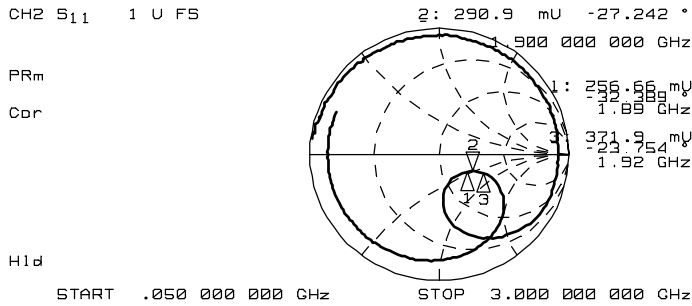
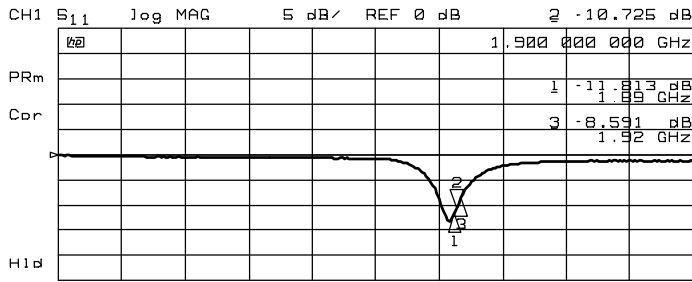

MIXER IN Impedance
Condition
LOCAL IN,IF OUT 50ohm
 $V_{LNA}=0V$
 $V_{MIX}=V_{LO}=2.7V$

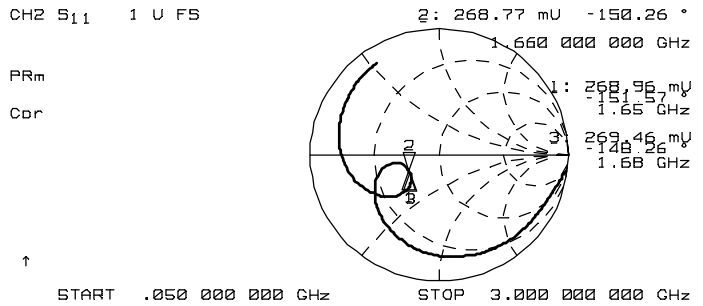
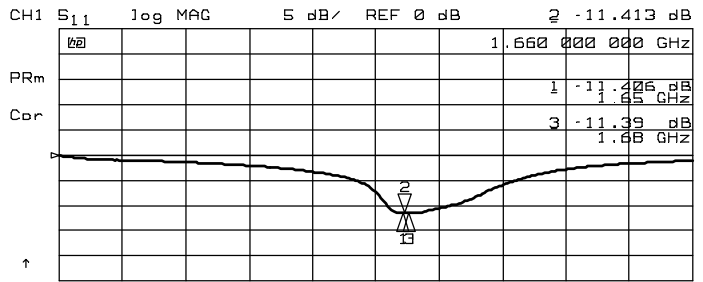

LOCAL IN Impedance
Condition
MIXER IN,IF OUT 50ohm
 $V_{LNA}=0V$
 $V_{MIX}=V_{LO}=2.7V$

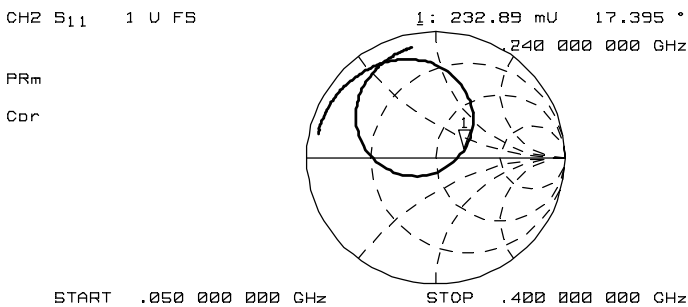
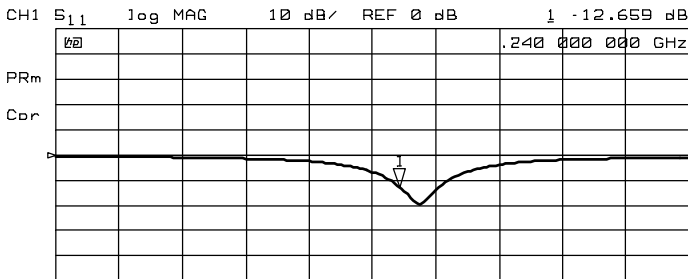

IF OUT Impedance
Condition
MIXER IN,LOCAL IN 50ohm
 $V_{LNA}=0V$
 $V_{MIX}=V_{LO}=2.7V$

■ TYPICAL CHARACTERISTICS 2 (MIXER, $f=1.9\text{GHz}$, $f_{LO}=1660\text{MHz}$, with test circuit)

Conversion Gain, Noise Figure vs. V_{MIX} , V_{LO}

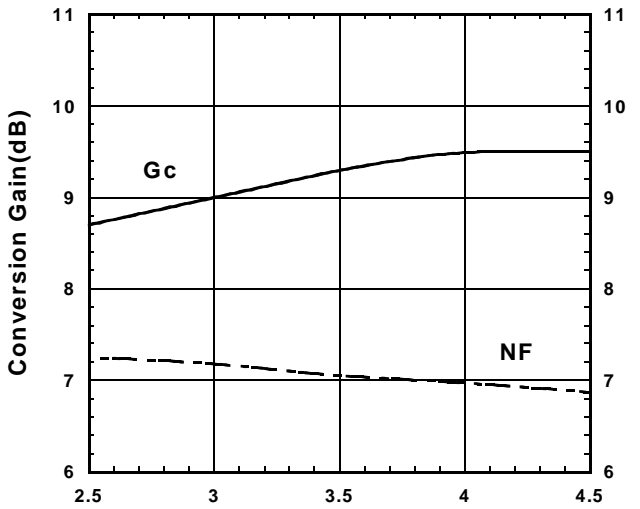

V_{MIX}, V_{LO} (V)
 Condition
 $f_{IF}=240\text{MHz}$
 $f_{RF}=1900\text{MHz}, P_{RF}=-30\text{dBm}$
 Lower LOCAL, $P_{LO}=-15\text{dBm}$
 $V_{LNA}=0\text{V}$
 $V_{MIX}=V_{LO}=2.5\sim 4.5\text{V}$

OIP3, IIP3 vs. V_{MIX} , V_{LO}

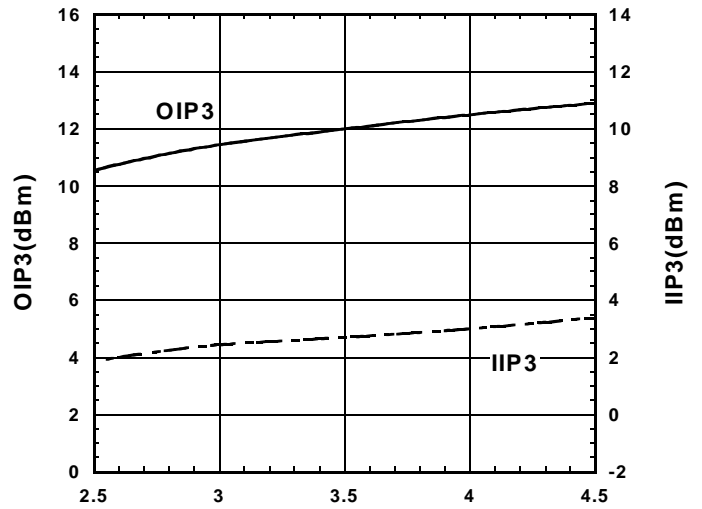

V_{MIX}, V_{LO} (V)
 Condition
 $f_{IF}=240\text{MHz}$
 $f_{RF}=1900\text{MHz}, P_{RF}=-30\text{dBm}$
 Lower LOCAL, $P_{LO}=-15\text{dBm}$
 $V_{LNA}=0\text{V}$
 $V_{MIX}=V_{LO}=2.5\sim 4.5\text{V}$

I_{MIX}, I_{LO} vs. V_{MIX}, V_{LO}

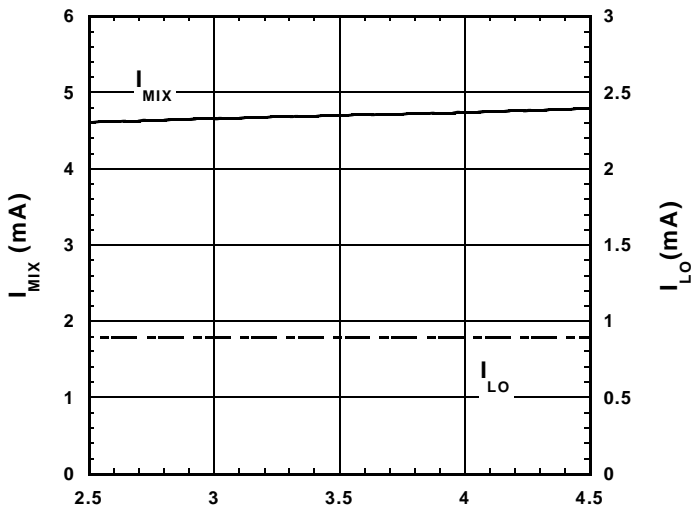

V_{MIX}, V_{LO} (V)
 Condition
 $f_{IF}=240\text{MHz}$
 $f_{RF}=1900\text{MHz}, P_{RF}=-30\text{dBm}$
 $f_{RF\ OFFSET}=100\text{kHz}$
 Lower LOCAL, $P_{LO}=-30\text{dBm}$
 $V_{LNA}=0\text{V}$
 $V_{MIX}=V_{LO}=2.5\sim 4.5\text{V}$

The value of OIP3 and IIP3 shown in typical characteristics are calculated

$$OIP3 = \frac{3 \times P_{out} - IM3}{2}$$

$$IIP3 = OIP3 - \text{Gain}$$

@Pin=-30dBm

NJG1714KC1

■ TYPICAL CHARACTERISTICS 2 (MIXER, $f=1.9\text{GHz}$, $f_{LO}=1660\text{MHz}$, with test circuit)

Conversion Gain vs. RF frequency
Temperature Response

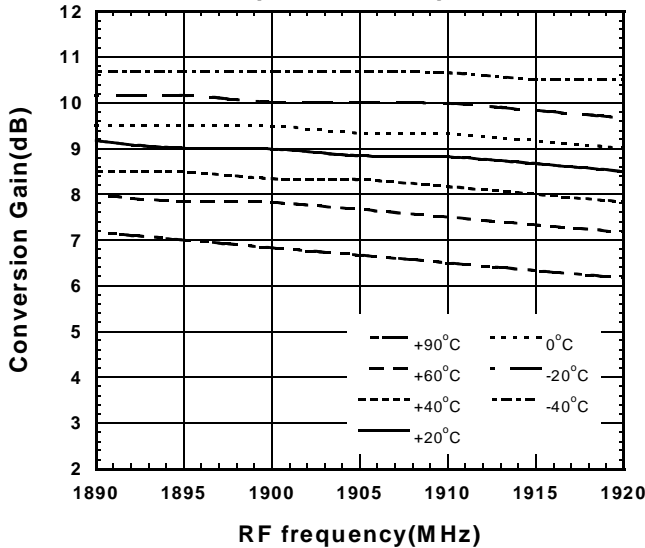

Condition
 $f_{IF}=240\text{MHz}$
 $f_{RF}=1890\sim 1920\text{MHz}$, $P_{RF}=-30\text{dBm}$
 Lower LOCAL, $P_{LO}=-15\text{dBm}$
 $V_{LNA}=0\text{V}$
 $V_{MIX}=V_{LO}=2.7\text{V}$

Noise Figure vs. RF frequency
Temperature Response

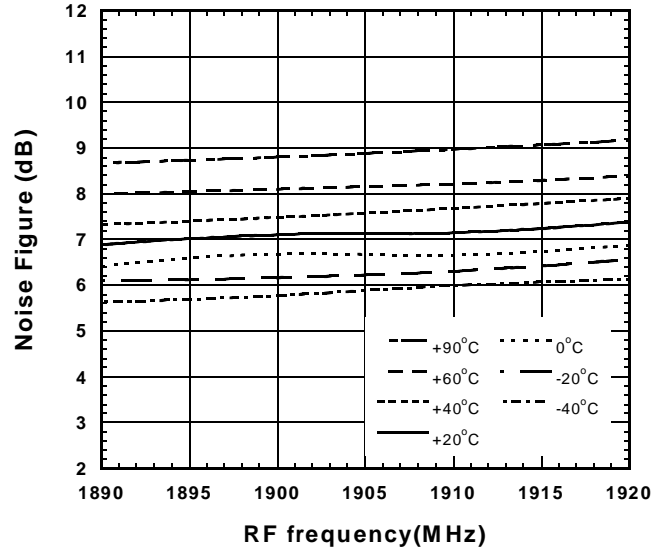

Condition
 $f_{IF}=240\text{MHz}$
 $f_{RF}=1890\sim 1920\text{MHz}$, $P_{RF}=-30\text{dBm}$
 Lower LOCAL, $P_{LO}=-15\text{dBm}$
 $V_{LNA}=0\text{V}$
 $V_{MIX}=V_{LO}=2.7\text{V}$

IIP3 vs. RF frequency
Temperature Response

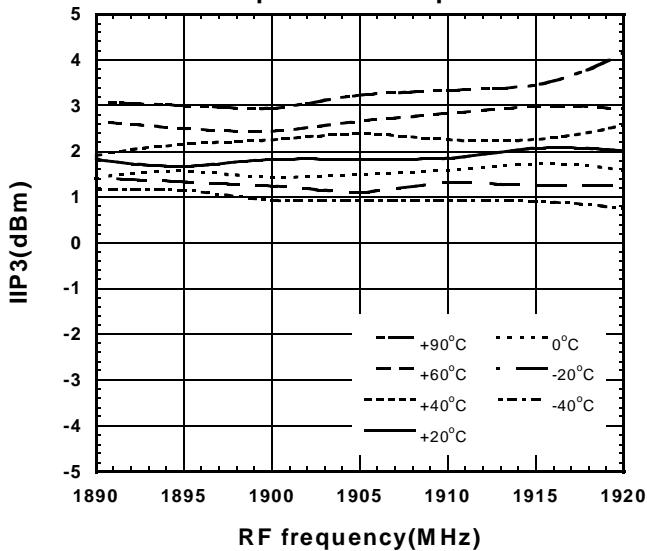

Condition
 $f_{IF}=240\text{MHz}$
 $f_{RF}=1890\sim 1920\text{MHz}$, $P_{RF}=-30\text{dBm}$
 $f_{RF\ OFFSET}=100\text{kHz}$
 Lower LOCAL, $P_{LO}=-15\text{dBm}$
 $V_{LNA}=0\text{V}$
 $V_{MIX}=V_{LO}=2.7\text{V}$

The value of OIP3 and IIP3 shown in typical characteristics are calculated

$$\text{OIP3} = \frac{3 \times \text{Pout} - \text{IM3}}{2}$$

$$\text{IIP3} = \text{OIP3} - \text{Gain}$$

@ $P_{in} = -30\text{dBm}$

■ TYPICAL CHARACTERISTICS 2 (MIXER, $f=1.9\text{GHz}$, $f_{LO}=1660\text{MHz}$, with test circuit)

Conversion Gain vs. LO Power Temperature Response

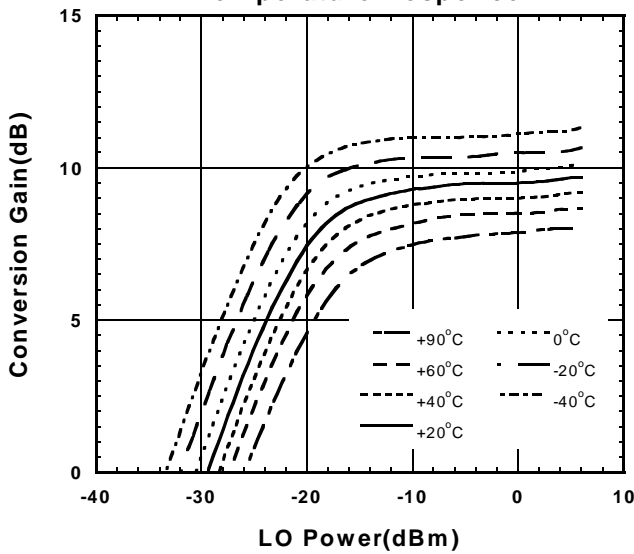

Condition
 $f_{IF}=240\text{MHz}$
 $f_{RF}=1900\text{MHz}, P_{RF}=-30\text{dBm}$
 $f_{LO}=1660\text{MHz}$
 $V_{LNA}=0\text{V}$
 $V_{MIX}=V_{LO}=2.7\text{V}$

Noise Figure vs. LO Power Temperature Response

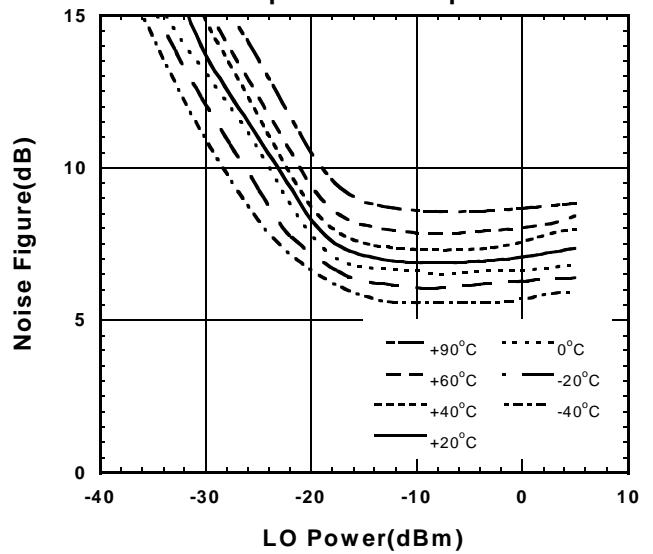

Condition
 $f_{IF}=240\text{MHz}$
 $f_{RF}=1900\text{MHz}, P_{RF}=-30\text{dBm}$
 $f_{LO}=1660\text{MHz}$
 $V_{LNA}=0\text{V}$
 $V_{MIX}=V_{LO}=2.7\text{V}$

IIP3 vs. LO Power Temperature Response

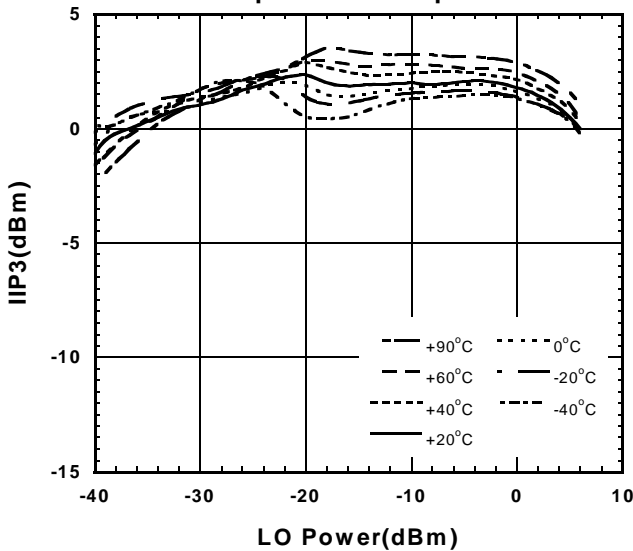

Condition
 $f_{IF}=240\text{MHz}$
 $f_{RF}=1900+1900.1\text{MHz}, P_{RF}=-30\text{dBm}$
 $f_{LO}=1660\text{MHz}$
 $V_{LNA}=0\text{V}$
 $V_{MIX}=V_{LO}=2.7\text{V}$

I_{MIX}, I_{LO} vs. Temperature

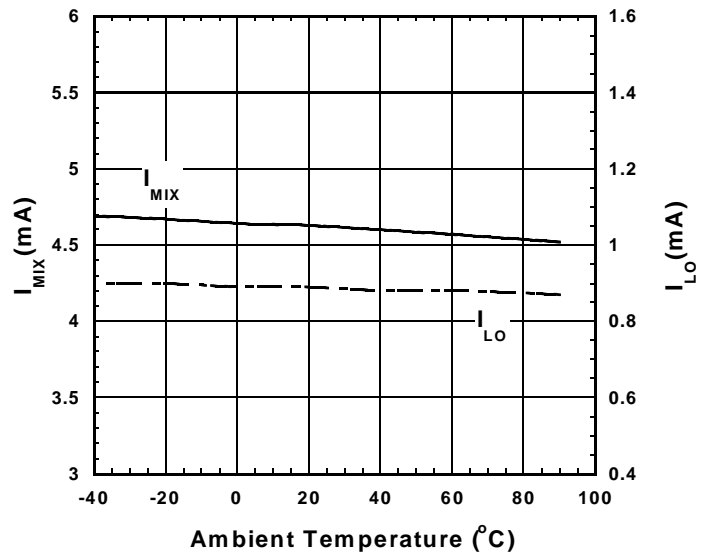

Condition
 $V_{LNA}=0\text{V}$
 $V_{MIX}=V_{LO}=2.7\text{V}$

The value of OIP3 and IIP3 shown in typical characteristics are calculated

$$\text{OIP3} = \frac{3 \times P_{\text{out}} - \text{IM3}}{2}$$

IIP3 = OIP3 - Gain

@ Pin = -30 dBm

NJG1714KC1

TYPICAL CHARACTERISTICS 3 (LNA+MIXER, $f_c=1.9\text{GHz}$, $f_{LO}=1660\text{MHz}$, with test circuit)

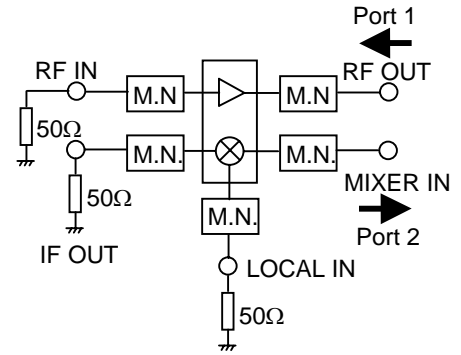
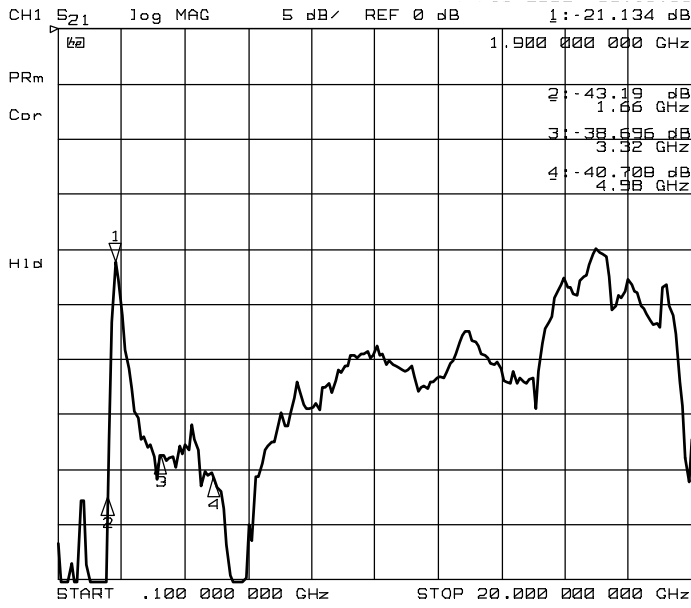

RF OUT → MIXER IN ISOLATION
 Condition
 RF IN, LOCAL IN, IF OUT 50ohm
 $V_{LNA}=V_{MIX}=V_{LO}=2.7\text{V}$

TEST CIRCUIT

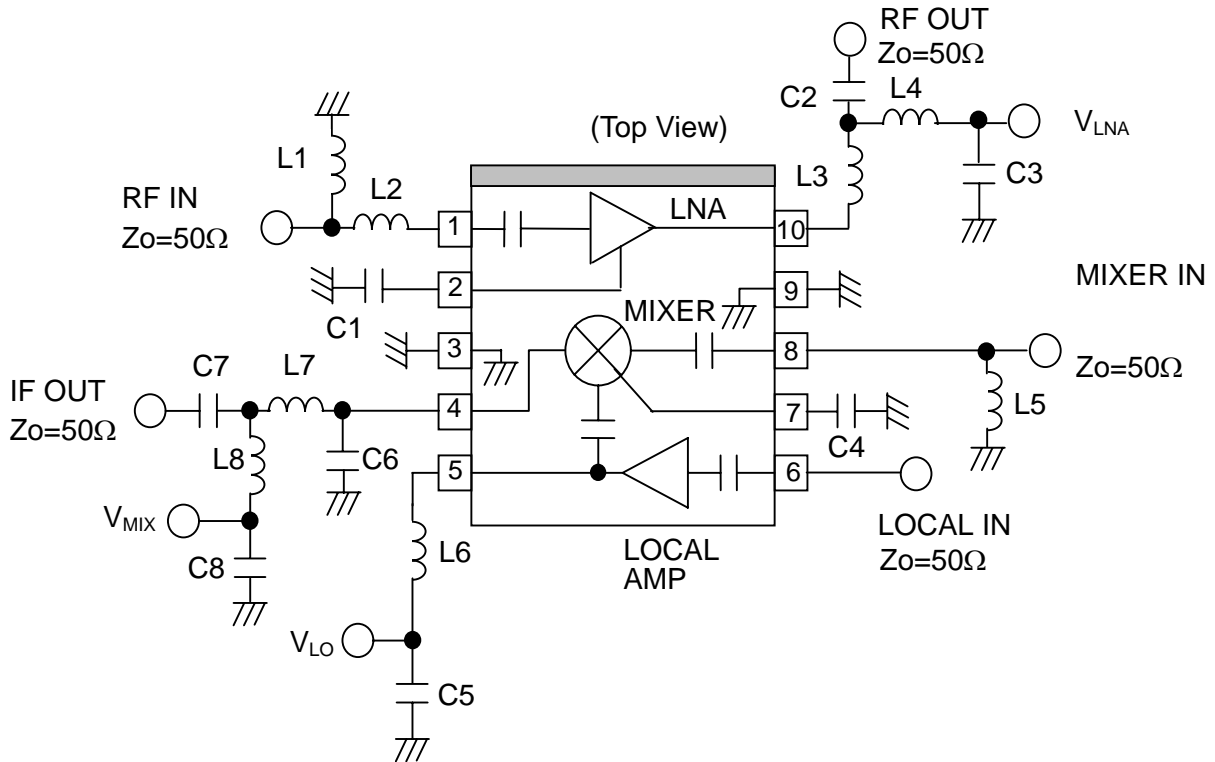

PARTS LIST

PART ID	1.9GHz BAND	COMMENT
	Lower LOCAL $f_{LO}=1660\text{MHz}$ $P_{LO}=-15\text{dBm}$ $f_{IF}=240\text{MHz}$	
L1	6.8nH	TAIYO-YUDEN (HK1005)
L2	6.8nH	TAIYO-YUDEN (HK1005)
L3	4.7nH	TAIYO-YUDEN (HK1005)
L4	1.5nH	TAIYO-YUDEN (HK1005)
L5	1.8nH	TAIYO-YUDEN (HK1005)
L6	8.2nH	TAIYO-YUDEN (HK1005)
L7	39nH	TAIYO-YUDEN (HK1608)
L8	22nH	TAIYO-YUDEN (HK1005)
C1	30pF	MURATA (GRM36)
C2	12pF	MURATA (GRM36)
C3	1000pF	MURATA (GRM36)
C4	1000pF	MURATA (GRM36)
C5	0.01uF	MURATA (GRM36)
C6	6.0pF	MURATA (GRM36)
C7	10pF	MURATA (GRM36)
C8	1000pF	MURATA (GRM36)
C9	0.01uF	MURATA (GRM36)

NJG1714KC1

RECOMMENDED PCB DESIGN

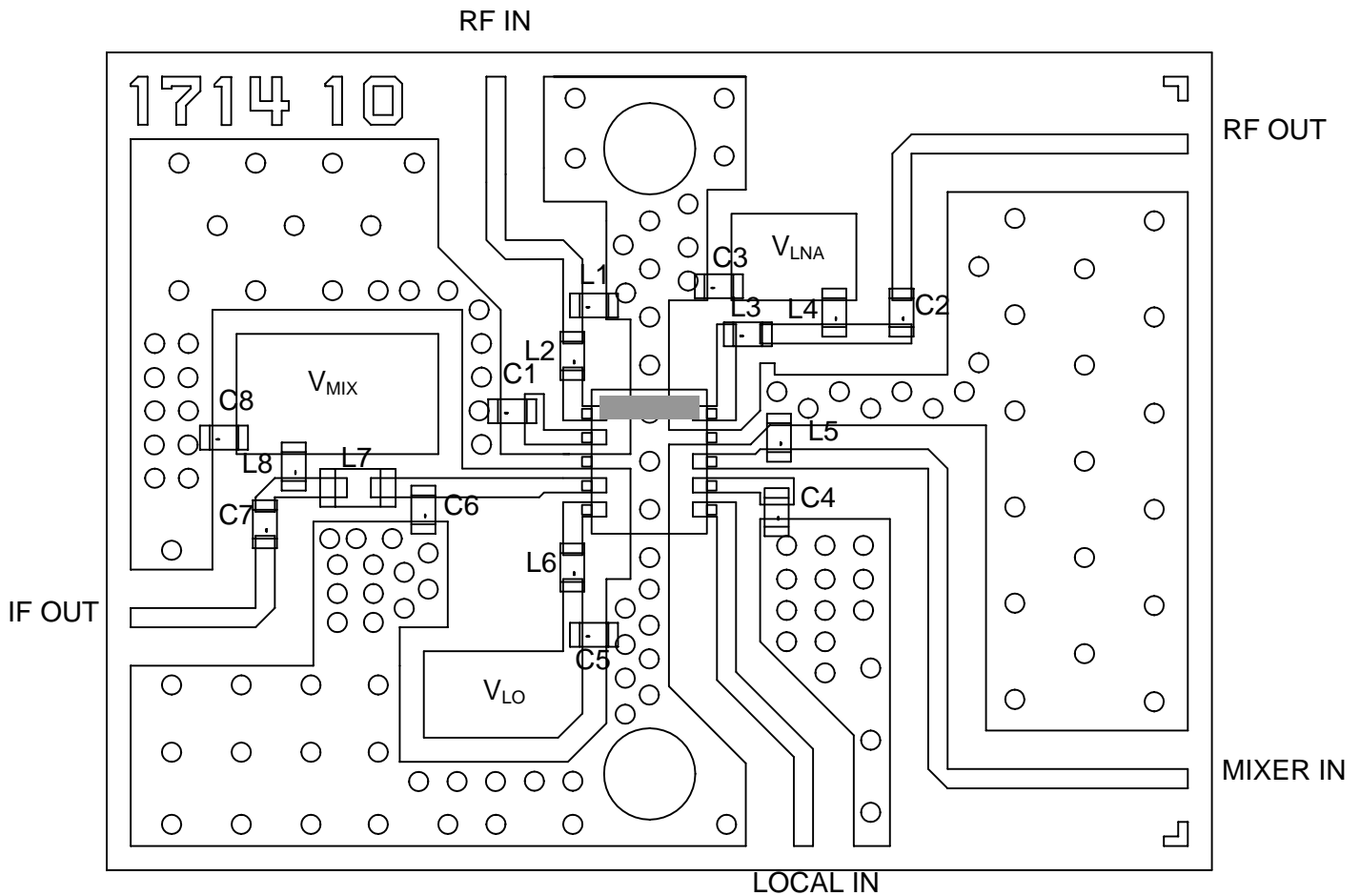

PCB (FR-4) : $t = 0.2 \text{ mm}$

MICRO STRIPLINE WIDTH = 0.4 mm ($Z_0 = 50\text{ohm}$)

PCB SIZE = $23.0 \times 17.0 \text{ mm}$

Caution on using devices

- [1] Please place L2 close to the LNA IN terminal (1st pin).
- [2] Please place C1 close to the LNACAP terminal (2nd pin).
- [3] Please place L5 close to the MIX IN terminal (8th pin).
- [4] Please place L6 close to the VLO terminal (5th pin).
- [5] Please place C5 close to L6.

MEASURING BLOCK DIAGRAM

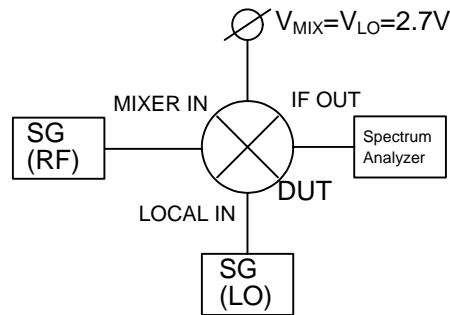

Conversion Gain Measurement Block Diagram

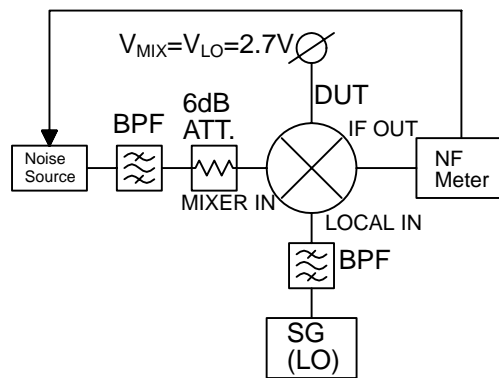

Noise Figure Measurement Block Diagram

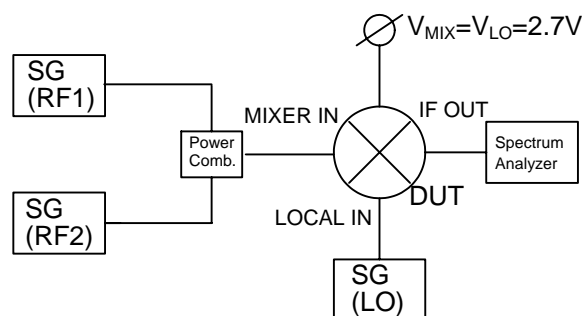

IF,IM3 Measurement Block Diagram

[CAUTION]

The specifications on this databook are only given for information , without any guarantee as regards either mistakes or omissions. The application circuits in this databook are described only to show representative usages of the product and not intended for the guarantee or permission of any right including the industrial rights.