

---

## MR27V3255D

---

1,048,576-Double Word x 32-Bit or 2,097,152-Word x 16-Bit

8-Double Word x 32-Bit or 16-Word x 16-Bit Page Mode One Time PROM

---

### DESCRIPTION

The MR27V3255D is a 32Mbit electrically Programmable Read-Only Memory with page mode. Its configuration can be electrically switched between 1,048,576 double word x 32bit and 2,097,152 word x 16bit. The MR27V3255D operates on a single +3.3V power supply and is TTL compatible. The MR27V3255D provides Page mode which can greatly reduce the read access time. Since the MR27V3255D operates asynchronously, external clocks are not required, making this device easy-to-use. The MR27V3255D is suitable as large-capacity fixed memory for microcomputers and data terminals. It is manufactured using a CMOS double silicon gate technology and is offered in 70-pin SSOP or 70-pin TSOP packages.

### FEATURES

- 1,048,576 double word x 32bit / 2,097,152 word x 16bit electrically switchable configuration
- Single +3.3V power supply
- Access time 80ns
  - Page mode access time 25ns
- Input / Output TTL compatible
- Three-state output
- Packages

70-pin plastic SSOP (SSOP70-P-500-0.80-K)  
70-pin plastic TSOP (TSOP II 70-P-400-0.65-K)

## PIN CONFIGURATION (TOP VIEW)

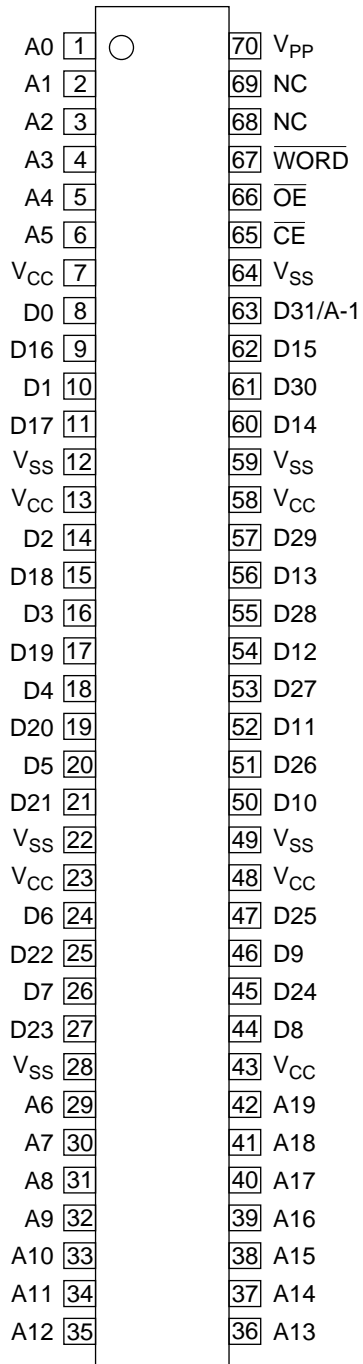

70-pin SSOP , TSOP

PIN NAMES	FUNCTIONS
D31/A-1	Data output / Address input
A0 - A19	Address input
D0 - D30	Data output
CE	Chip enable
OE	Output enable
V <sub>CC</sub>	Power supply voltage
V <sub>SS</sub>	GND
WORD	Mode switch
V <sub>PP</sub>	Program power supply voltage
NC	Non connection

## BLOCK DIAGRAM

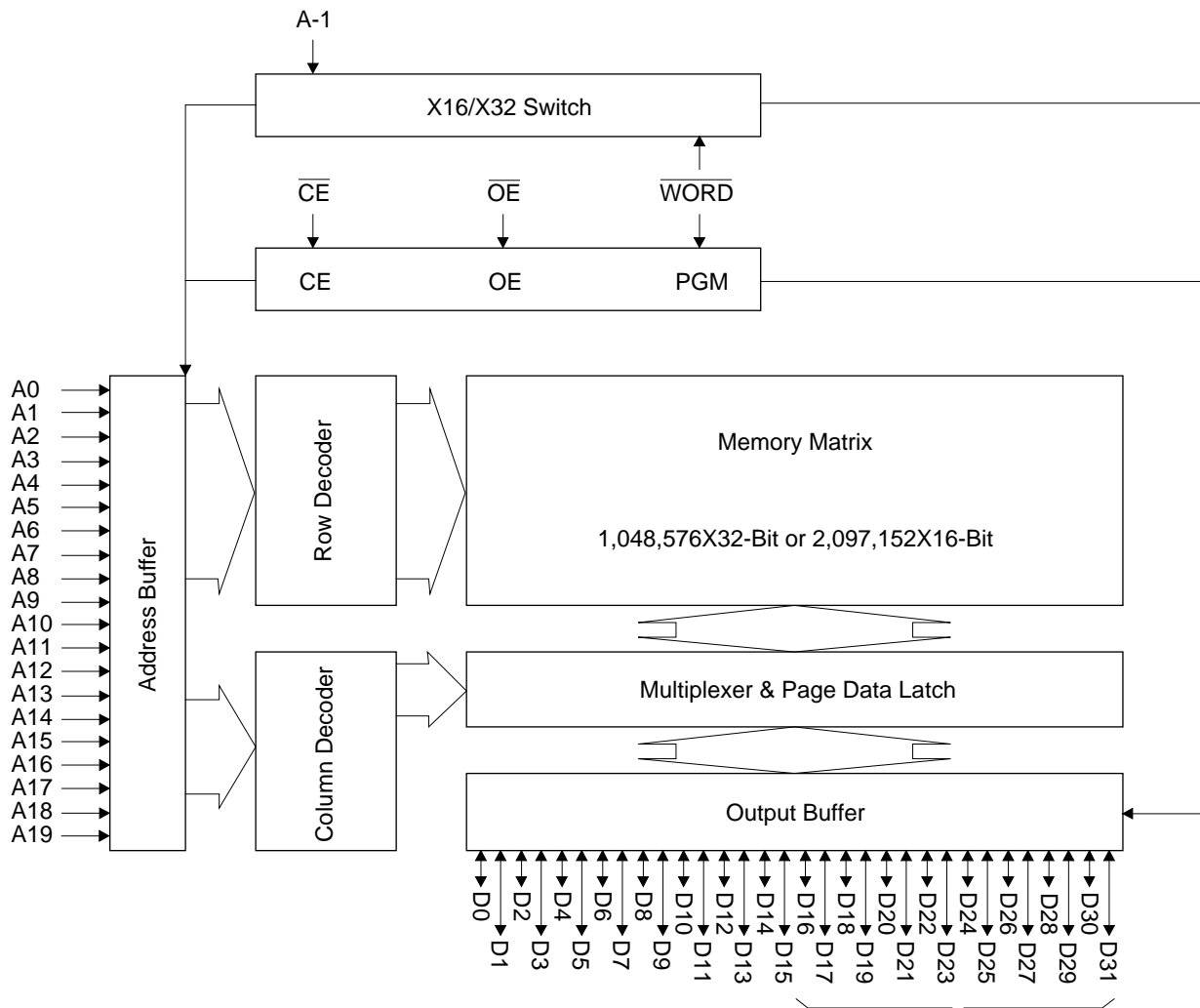

In 16-bit output mode, these pins are three-stated and pin D31 functions as the A-1 address pin.

## FUNCTION TABLE

MODE	CE	OE	WORD	V <sub>PP</sub>	V <sub>CC</sub>	D0 - D15	D16 - D30	D31/A-1
READ (32-Bit)	L	L	H	*	3.3V	D <sub>OUT</sub>		
READ (16-Bit)	L	L	L			D <sub>OUT</sub>	Hi-Z	L/H
OUTPUT DISABLE	L	H	H			Hi-Z		*
			L			Hi-Z		*
STAND-BY	H	*	H	Hi-Z		*		
			L	Hi-Z		*		
PROGRAM	L	H	L	9.75V	4.0V	D <sub>IN</sub>	Hi-Z	L/H
PROGRAM INHIBIT	H	H				Hi-Z		
PROGRAM VERIFY	H	L				D <sub>OUT</sub>	Hi-Z	L/H

\*: Don't Care

**ABSOLUTE MAXIMUM RATINGS**

Parameter	Symbol	Condition	Value	Unit
Operating temperature under bias	$T_{opr}$	-	0 to 70	°C
Storage temperature	$T_{stg}$	-	-55 to 125	°C
Input voltage	$V_I$	relative to $V_{SS}$	-0.5 to $V_{CC} + 0.5$	V
Output voltage	$V_O$		-0.5 to $V_{CC} + 0.5$	V
Power supply voltage	$V_{CC}$		-0.5 to 5	V
Program power supply voltage	$V_{PP}$		-0.5 to 11.5	V
Power dissipation per package	$P_D$	-	1.0	W

**RECOMMENDED OPERATING CONDITIONS FOR READ**

(Ta=0 to 70°C)

Parameter	Symbol	Condition	Min.	Typ.	Max.	Unit
$V_{CC}$ power supply voltage	$V_{CC}$	$V_{CC}=3.0V-3.6V$	3.0	-	3.6	V
$V_{PP}$ power supply voltage	$V_{PP}$		-0.5	-	$V_{CC}+0.5$	V
Input "H" level	$V_{IH}$		2.2	-	$V_{CC}+0.5$	V
Input "L" level	$V_{IL}$		-0.5	-	0.6	V

Voltage is relative to  $V_{SS}$

**ELECTRICAL CHARACTERISTICS (Read operation)****DC Characteristics** $(V_{CC}=3.3V\pm 0.3V, T_a=0 \text{ to } 70^\circ\text{C})$ 

Parameter	Symbol	Condition	Min.	Typ.	Max.	Unit
Input leakage current	$I_{LI}$	$V_I=0 \text{ to } V_{CC}$	-	-	10	$\mu\text{A}$
Output leakage current	$I_{LO}$	$V_O=0 \text{ to } V_{CC}$	-	-	10	$\mu\text{A}$
$V_{CC}$ power supply current (Standby)	$I_{CS1}$	$\overline{CE}=V_{CC}$	-	-	50	$\mu\text{A}$
	$I_{CS2}$	$\overline{CE}=V_{IH}$	-	-	1	$\text{mA}$
$V_{CC}$ power supply current (Read)	$I_{CCA}$	$\overline{CE}=V_{IL}, \overline{OE}=V_{IH}$ $t_c=80\text{ns}$	-	-	100	$\text{mA}$
$V_{PP}$ power supply current	$I_{PP}$	$V_{PP}=V_{CC}$	-	-	10	$\mu\text{A}$
Input "H" level	$V_{IH}$	-	2.2	-	$V_{CC}+0.5$	V
Input "L" level	$V_{IL}$	-	-0.5	-	0.6	V
Output "H" level	$V_{OH}$	$I_{OH}=-200\mu\text{A}$	$V_{CC}-0.4$	-	-	V
Output "L" level	$V_{OL}$	$I_{OL}=1\text{mA}$	-	-	0.4	V

Voltage is relative to  $V_{SS}$ **AC Characteristics** $(V_{CC}=3.3V\pm 0.3V, T_a=0 \text{ to } 70^\circ\text{C})$ 

Parameter	Symbol	Condition	Min.	Max.	Unit
Address access cycle time	$T_C$	-	80	-	ns
Address access time	$T_{ACC}$	$\overline{CE}=\overline{OE}=V_{IL}$	-	80	ns
Page access cycle time	$T_{PC}$	-	25	-	ns
Page access time	$T_{PAC}$	-	-	25	ns
$\overline{CE}$ access time	$T_{CE}$	$\overline{OE}=V_{IL}$	-	80	ns
$\overline{OE}$ access time	$T_{OE}$	$\overline{CE}=V_{IL}$	-	25	ns
Output disable time	$T_{CHZ}$	$\overline{OE}=V_{IL}$	0	25	ns
	$T_{OHZ}$	$\overline{CE}=V_{IL}$	0	20	ns
Output hold time	$T_{OH}$	$\overline{CE}=\overline{OE}=V_{IL}$	0	-	ns

## Measurement conditions

Input signal level	-----	0V/3V
Input timing reference level	-----	0.8V/2.0V
Output load	-----	100pF
Output timing reference level	-----	0.8V/2.0V

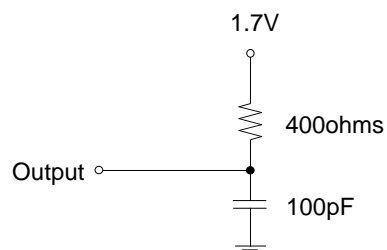

## TIMING CHART

## NORMAL MODE READ CYCLE

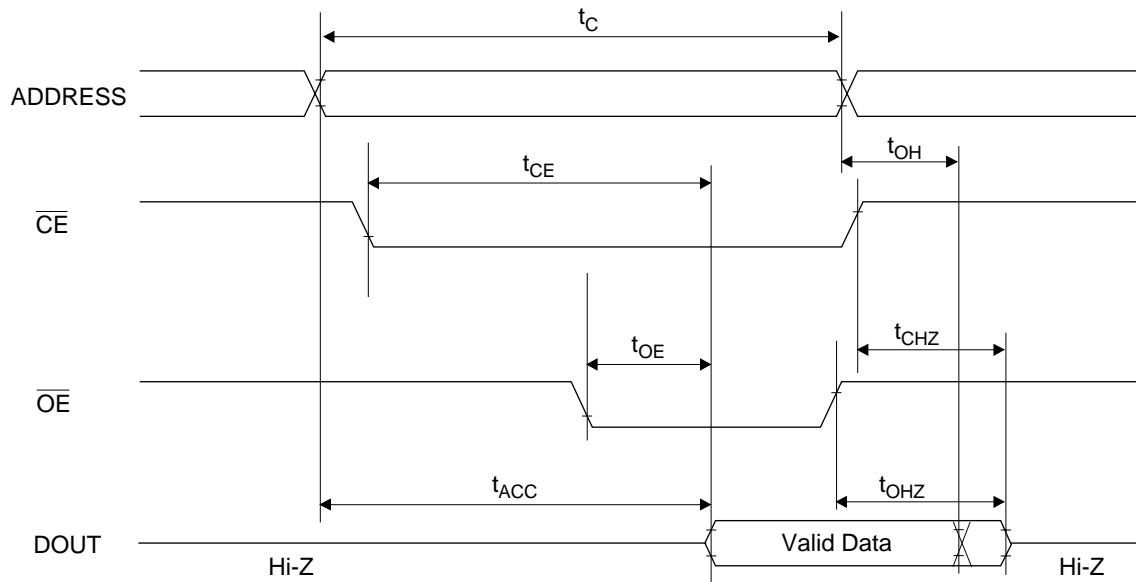

## PAGE MODE READ CYCLE

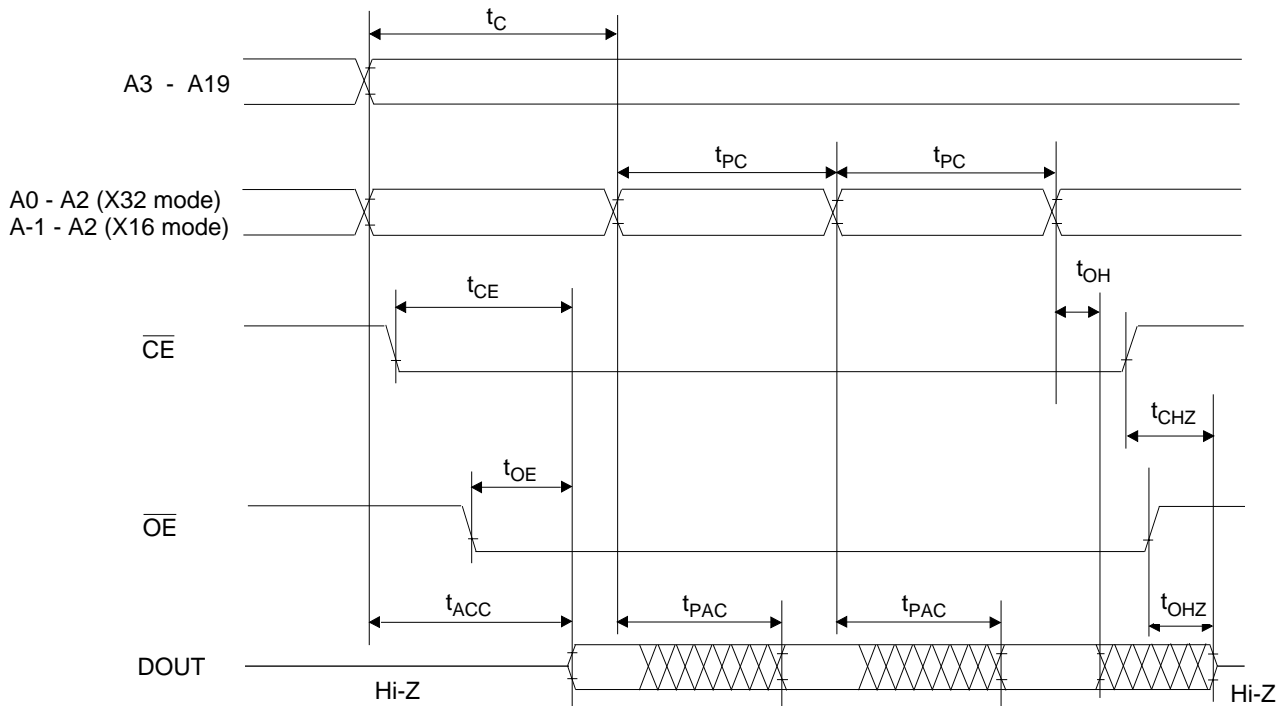

## ELECTRICAL CHARACTERISTICS (Programming operation)

### DC Characteristics

(Ta=25°C±5°C)

Parameter	Symbol	Condition	Min.	Typ.	Max.	Unit
Input leakage current	I <sub>LI</sub>	V <sub>I</sub> =V <sub>CC</sub> +0.5V	-	-	10	μA
V <sub>PP</sub> power supply current (Program)	I <sub>PP2</sub>	$\overline{CE}=V_{IL}$	-	-	50	mA
V <sub>CC</sub> power supply current	I <sub>CC</sub>	-	-	-	80	mA
Input "H" level	V <sub>IH</sub>	-	3.0	-	V <sub>CC</sub> +0.5	V
Input "L" level	V <sub>IL</sub>	-	-0.5	-	0.8	V
Output "H" level	V <sub>OH</sub>	I <sub>OH</sub> =-400μA	2.4	-	-	V
Output "L" level	V <sub>OL</sub>	I <sub>OL</sub> =2.1mA	-	-	0.45	V
Program voltage	V <sub>PP</sub>	-	9.5	9.75	10.0	V
V <sub>CC</sub> power supply voltage	V <sub>CC</sub>	-	3.9	4.0	4.1	V

Voltage is relative to V<sub>SS</sub>

### AC Characteristics

(V<sub>CC</sub>=4.0V±0.1V, V<sub>PP</sub>=9.75V±0.25V, Ta=25°C±5°C)

Parameter	Symbol	Condition	Min.	Typ.	Max.	Unit
Address set-up time	T <sub>AS</sub>	-	100	-	-	ns
$\overline{OE}$ set-up time	T <sub>OES</sub>	-	2	-	-	μs
Data set-up time	T <sub>DS</sub>	-	100	-	-	ns
Address hold time	T <sub>AH</sub>	-	2	-	-	μs
Data hold time	T <sub>DH</sub>	-	100	-	-	ns
Output float delay from $\overline{OE}$	T <sub>OHZ</sub>	-	0	-	100	ns
V <sub>PP</sub> voltage set-up time	T <sub>VS</sub>	-	2	-	-	μs
Program pulse width	T <sub>PW</sub>	-	9	10	11	μs
Data valid from $\overline{OE}$	T <sub>OE</sub>	-	-	-	100	ns
Address hold from $\overline{OE}$ high	T <sub>AHO</sub>	-	0	-	-	ns

### Pin Check Function

Pin Check Function is to check contact between each device-pin and each socket-lead with EPROM programmer.

Setting up address as the following condition call the preprogrammed codes on device outputs.

(V<sub>CC</sub>=3.3V±0.3V,  $\overline{CE}=\overline{OE}=V_{IL}$ ,  $\overline{WORD}=V_{IL}$ , Ta=25°C±5°C)

PA0	PA1	PA2	PA3	PA4	PA5	PA6	PA7	PA8	PA9	PA10	PA11	PA12	PA13	PA14	PA15	PA16	PA17	PA18	PA19	PA20	DATA
A-1	A0	A1	A2	A3	A4	A5	A6	A7	A8	A9	A10	A11	A12	A13	A14	A15	A16	A17	A18	A19	
0	1	0	1	0	1	0	1	0	1	VH*	1	0	1	0	1	0	1	0	1	0	AAAA
1	0	1	0	1	0	1	0	1	0	VH*	0	1	0	1	0	1	0	1	0	1	5555
Other conditions																				FFFF	

\* :VH=8V±0.25V

### Consecutive Programming Waveforms

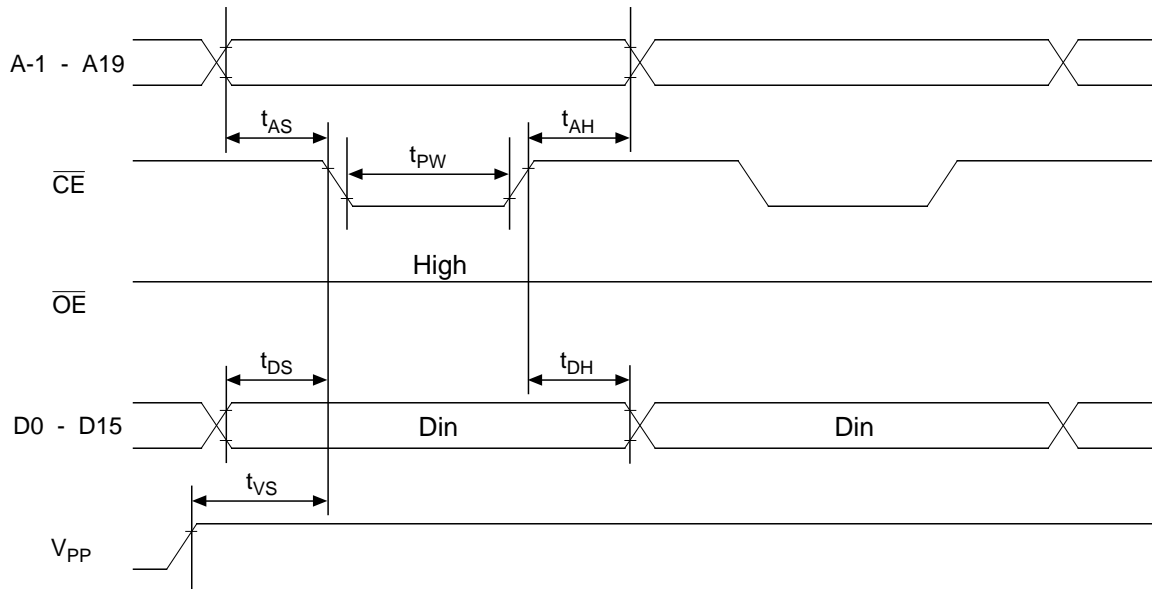

### Consecutive Program Verify Waveforms

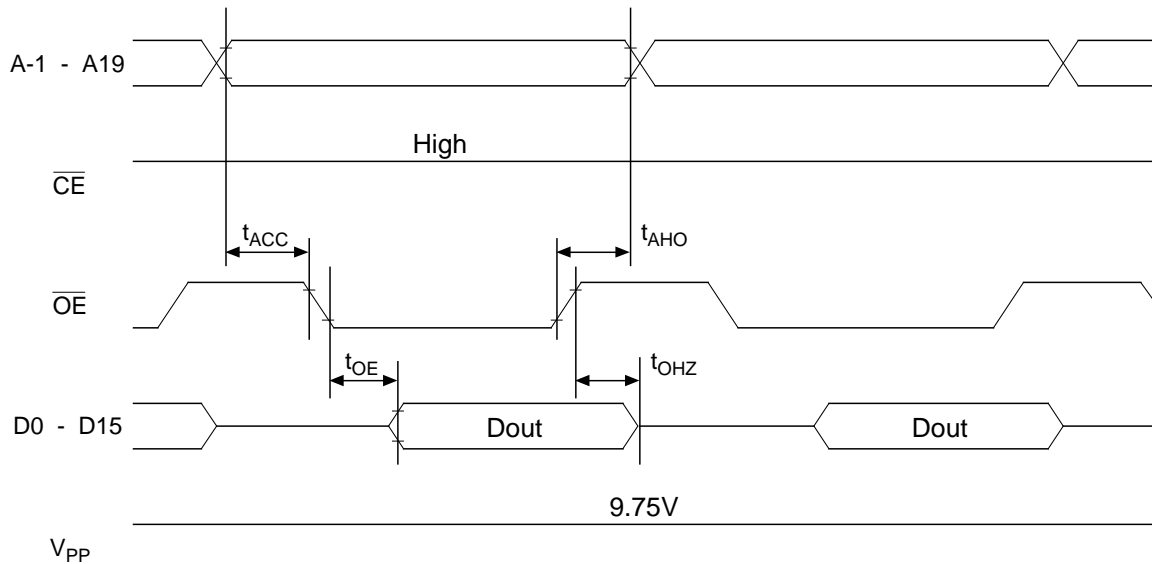

### Program and Program Verify Cycle Waveforms

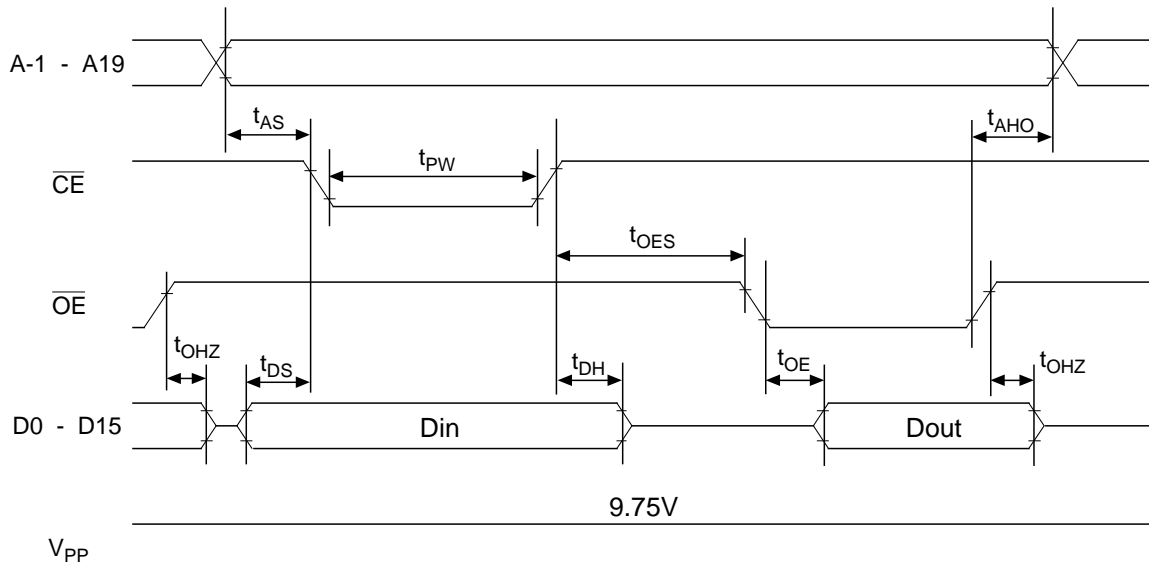

### PIN Capacitance

( $V_{CC}=3.3V$ ,  $T_a=25^\circ C$ ,  $f=1MHz$ )

Parameter	Symbol	Condition	Min.	Typ.	Max.	Unit
Input	$C_{IN}$	$V_I=0V$	-	-	12	pF
Output	$C_{OUT}$	$V_O=0V$	-	-	15	

Programming / Verify Flow Chart

Programming

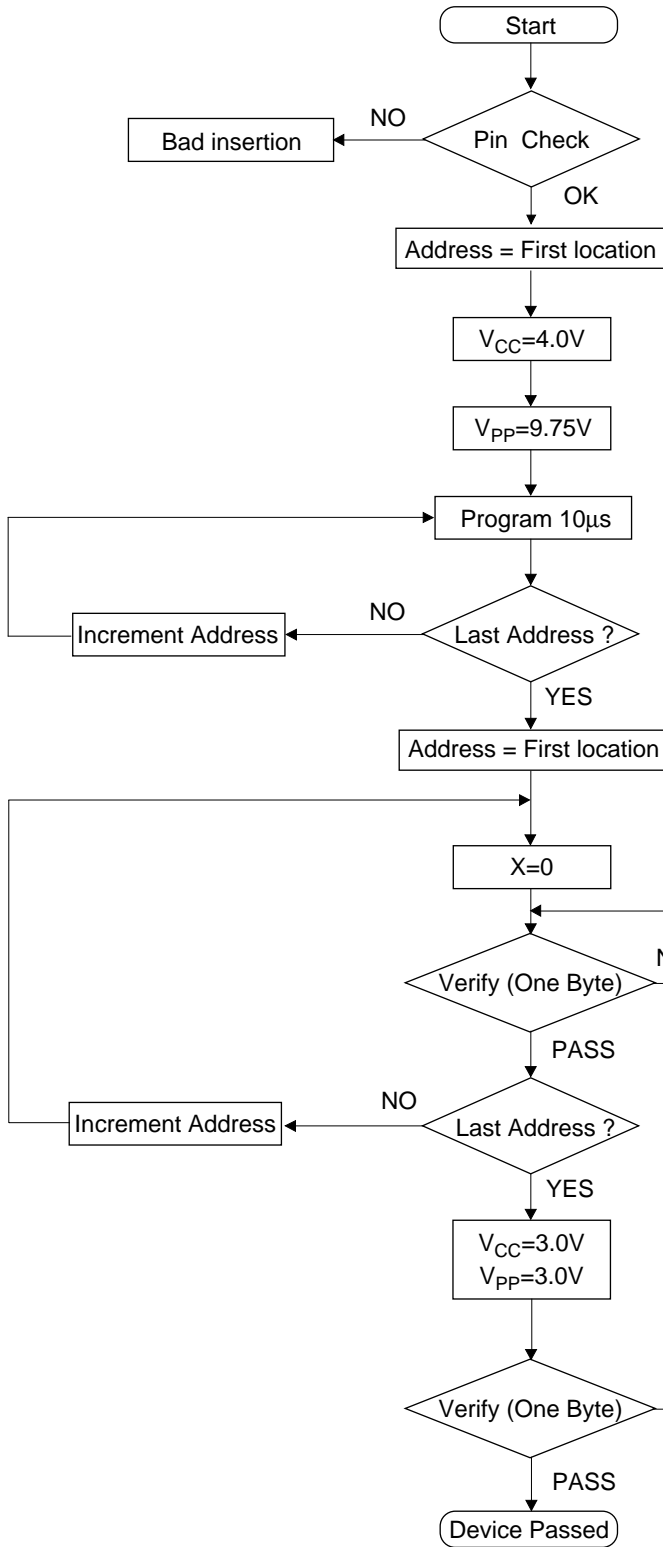

Verify

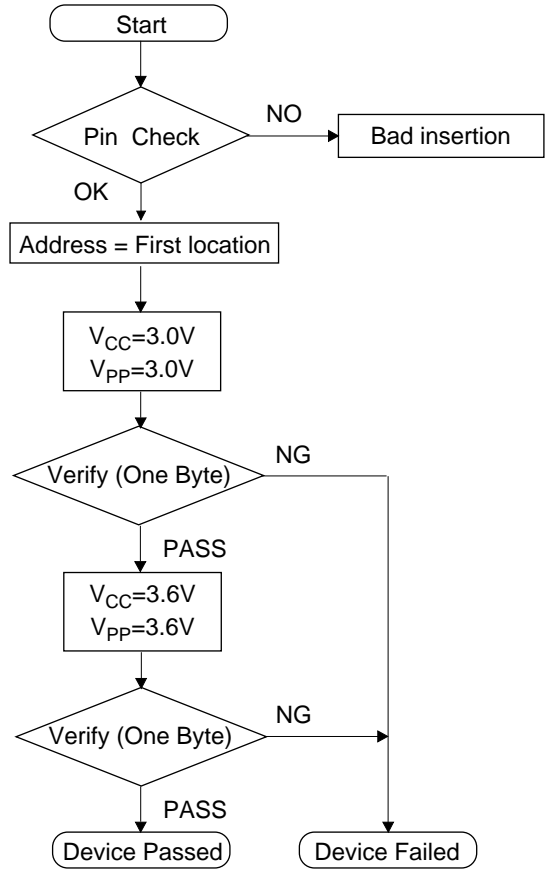

## **NOTICE**

The information contained herein can change without notice owing to product and/or technical improvements. Before using the product, please make sure that the information being referred to is up-to-date.

The outline of action and examples for application circuits described herein have been chosen as an explanation for the standard action and performance of the product. When planning to use the product, please ensure that the external conditions are reflected in the actual circuit, assembly, and program designs.

When designing your product, please use our product below the specified maximum ratings and within the specified operating ranges including, but not limited to, operating voltage, power dissipation, and operating temperature.

Oki assumes no responsibility or liability whatsoever for any failure or unusual or unexpected operation resulting from misuse, neglect, improper installation, repair, alteration or accident, improper handling, or unusual physical or electrical stress including, but not limited to, exposure to parameters beyond the specified maximum ratings or operation outside the specified operating range.

Neither indemnity against nor license of a third party's industrial and intellectual property right, etc. is granted by us in connection with the use of the product and/or the information and drawings contained herein. No responsibility is assumed by us for any infringement of a third party's right which may result from the use thereof.

The products listed in this document are intended for use in general electronics equipment for commercial applications (e.g., office automation, communication equipment, measurement equipment, consumer electronics, etc.). These products are not authorized for use in any system or application that requires special or enhanced quality and reliability characteristics nor in any system or application where the failure of such system or application may result in the loss or damage of property, or death or injury to humans. Such applications include, but are not limited to, traffic and automotive equipment, safety devices, aerospace equipment, nuclear power control, medical equipment, and life-support systems.

Certain products in this document may need government approval before they can be exported to particular countries. The purchaser assumes the responsibility of determining the legality of export of these products and will take appropriate and necessary steps at their own expense for these.

No part of the contents contained herein may be reprinted or reproduced without our prior permission.

All brand, company and product names are the trademarks or registered trademarks of their respective owners.

Copyright 1998 Oki Electric Industry Co., Ltd.  
Marketing Communications Team (RB)

# OKI

People To People Technology

## ADDRESSES & SEMICONDUCTOR WEB SITES

### **OKI Electric Industry Co., Ltd.,**

Device Business Group,  
10-3, Shibaura, 4-chome,  
Minato-ku, Tokyo 108, Japan,  
Tel.: +81-(0)3-5445-6327,  
Fax.: +81-(0)3-5445-6328,  
<http://www.oki.co.jp/semi/>

### **OKI Semiconductor Group,**

785 North Mary Avenue,  
Sunnyvale, CA 94086, U.S.A.,  
Tel.: +1-408-720-1900,  
Fax.: +1-408-720-1918,  
<http://www.okisemi.com/>

### **OKI Electric Europe GmbH,**

Head Office Europe,  
Hellersbergstrasse 2,  
D-41460 Neuss, Germany,  
Tel: +49-2131-15960,  
Fax: +49-2131-103539,  
<http://www.oki-europe.de/>

### **OKI Electronics (Hong Kong) Ltd.,**

Suite 1901-1&19, Tower 3,  
China Hong Kong City,  
33 Canton Road, Tsimshatsui,  
Kowloon, Hong Kong,  
Tel.: +852-2-736-2336,  
Fax.: +852-2-736-2395

### **OKI Semiconductor (Asia) Pte. Ltd.,**

78 Shenton Way 09-01,  
Singapore 0207,  
Tel.: +65-221-3722,  
Fax.: +65-323-5376

### **OKI Semiconductor (Asia) Pte. Ltd.,**

Taipei Branch,  
7th Fl. No.260, Tun Hwa North Road,  
Taipei, Taiwan, R.O.C.,  
Sumitomo-Flysun Building,  
Tel.: +886-2-2719-2561,  
Fax.: +886-2-2715-2892  
<http://www.oki.net.tw/>

*For further information, please contact:*