

Protection of Lithium Ion Batteries (four cells in series) Monolithic IC MM1294

Outline

This IC provides protection for lithium ion batteries in the event of overcharging, overdischarging and overcurrents. When anomalies occur during charging or at other times and excessive voltages are applied, after a certain time has elapsed for each cell an external FET switch is turned off (overcharging detection); and in order to prevent overdischarge of the battery during discharge, when the voltage of individual batteries falls below a fixed voltage, an external FET switch is turned off (overdischarge detection), and the IC is put into low-consumption current mode. When large currents flow due to a short-circuit or other cause, an external MOS switch is turned off (overcurrent detection).

4-Cell Protection ICs

Temperature conditions A: $T_a = -25 \sim 75^\circ\text{C}$, B: $T_a = -20 \sim 70^\circ\text{C}$, C: $T_a = 0 \sim 50^\circ\text{C}$,
D: $T_a = 0 \sim 40^\circ\text{C}$, E: $T_a = -20 \sim 25^\circ\text{C}$

Model	Package	Overcharge detection voltage (V)	Overcharge detection voltage temperature conditions	Overcharge detection hysteresis voltage (V)	Overdischarge detection voltage (V)	Overdischarge reset voltage (V)	Overcurrent detection voltage (mV)
	SSOP-16						
MM1294	AJ	4.350±0.050	B	200±60	2.35±0.10	3.05±0.15	150±15
	BJ	4.250±0.050	B	200±60	2.40±0.10	3.10±0.15	150±15
	GJ	4.350±0.050	B	200±60	2.35±0.10	3.05±0.15	150±15

Features

- | | | |
|--|--------------------------------------|--|
| 1. Current consumption (overcharging) | $V_{\text{CELL}} > V_{\text{CELLU}}$ | 170µA typ. |
| 2. Current consumption (normal operation) | $V_{\text{CELL}} < V_{\text{ALM}}$ | 35µA typ. |
| 3. Current consumption (overdischarge) | $V_{\text{CELL}} < V_{\text{CELLS}}$ | 0.1µA max. |
| 4. Overcharge sensing dead time | $C = 0.1\mu\text{F}$ | 1.0S typ. |
| 5. Overcharge sensing operation voltage | $V_{\text{CELL}} : L \rightarrow H$ | A, G: 4.20V±150mV/CELL
B: 4.10V±150mV/CELL |
| 6. Overdischarge sensing dead time | $C = 0.1\mu\text{F}$ | 1.0S typ. |
| 7. Overcurrent detection voltage | | 0.15V typ. |
| 8. Overcurrent protection circuit | | A, B; Load open 300kΩ or higher
G; charging reset |
| 9. Overcharge and overdischarge voltages as well as the overcurrent detection voltage can be changed upon request. | | |

Package

SSOP-16

Applications

Lithium ion battery pack for notebook computers

Block Diagram

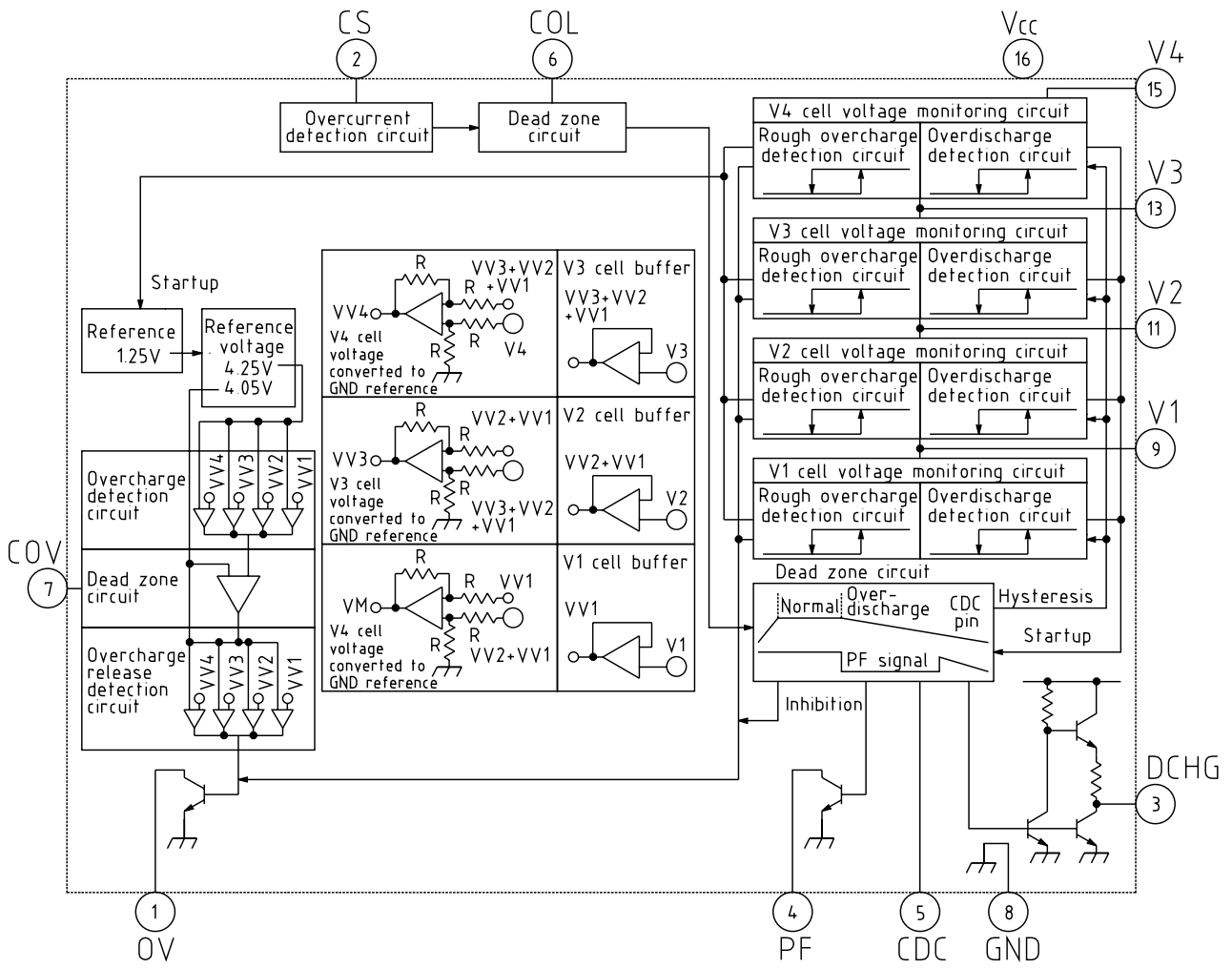

Pin Assignment

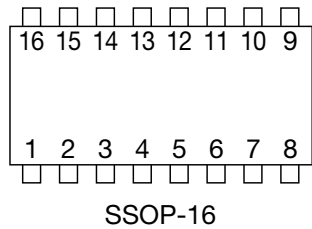

1	OV	9	V1
2	CS	10	N.C
3	DCHG	11	V2
4	PF	12	N.C
5	CDC	13	V3
6	COL	14	N.C
7	COV	15	V4
8	GND	16	V _{CC}

Pin Description

Pin no.	Pin name	Input/output	Function
1	OV	Output	Overcharge detection output pin NPN transistor open collector output; normally high impedance, goes to L level on overdischarge
2	CS	Input	Overcurrent detection pin Monitors equivalent load current through source-drain voltage drop of discharge-controlling FET, and at or above the overcurrent detection voltage sets the DCHG pin to "H" and turns off the discharge-controlling FET. Following overcurrent detection, current is passed from this pin, and if the load is decreased, the overcurrent mode is canceled. Through this action there is a temporary consumption current (at the Vcc pin) of approx. 1 mA on resumption of discharge and detection of overdischarge. This function is disabled in overdischarge mode.
3	DCHG	Output	Pin driving the discharge-controlling FET (P-ch) Normally "L"; on overdischarge set to "H" Output pin for overdischarge detection signals
4	PF	Output	Overdischarge detection signal output pin When the overdischarge detector detects overdischarge at the open collector output of the NPN transistor, this pin is turned on. A delay is provided by setting a dead time until discharge ends, so that by utilizing a reset or other signal from a CPU or some other controlling device, the equipment can be put into standby mode.
5	CDC	Input	Pin to set the dead time for overdischarge detection By connecting a capacitor between the CDC pin and GND, a dead time can be set.
6	COL	Input	Pin to set the dead time for overcurrent detection By connecting a capacitor between the COL pin and GND, a dead time can be set. If NC, protection is triggered in a short amount of time; the dead time should be set according to the application.
7	COV	Input	Pin to set the dead time for overcharge detection By connecting a capacitor between the COV pin and GND, a dead time can be set.
8	GND	Input	Ground pin
9	V1	Input	Pin for input of V1 cell high-side voltage and V2 cell low-side voltage
10	N.C		Non connected
11	V2	Input	Pin for input of V2 cell high-side voltage and V3 cell low-side voltage
12	N.C		Non connected
13	V3	Input	Pin for input of V3 cell high-side voltage and V4 cell low-side voltage
14	N.C		Non connected
15	V4	Input	Pin for input of V4 cell high-side voltage
16	Vcc	Input	Power supply input pin The same potential as the V4 pin should be input

Absolute Maximum Ratings

Item	Symbol	Ratings	Units
Storage temperature	T _{STG}	-40~+125	°C
Operating temperature	T _{OPR}	-20~+70	°C
Charge voltage	V _{V4} max.	24	V
Power supply voltage	V _{CC} max.	24	V
Voltage applied to OV pin	V _{OV} max.	24	V
Allowable loss	P _d	300	mW

Recommended Operating Conditions

Item	Symbol	Ratings	Units
Operating temperature	T _{OPR}	-20~+70	°C
Operating voltage	V _{OPR}	+2~+24	V

Electrical Characteristics (Except where noted otherwise, Ta=25°C, V_{CC}=20V, V_{CELL}=V₄=V₃=V₂=V₁) Models listed MM1294B

Item	Symbol	Measurement conditions	Min.	Typ.	Max.	Units
Consumption current (V _{CC} pin) 1	I _{CC1}	V _{CELL} =4.4V		170	340	μA
Consumption current (V _{CC} pin) 2	I _{CC2}	V _{CELL} =3.5V		35	70	μA
Consumption current (V _{CC} pin) 3	I _{CC3}	V _{CELL} =2.2V			0.1	μA
Consumption current (V ₄ pin) 1	I _{V41}	V _{CELL} =4.4V		15	30	μA
Consumption current (V ₄ pin) 2	I _{V42}	V _{CELL} =3.5V		5	10	μA
Consumption current (V ₄ pin) 3	I _{V43}	V _{CELL} =2.2V		2	4	μA
V ₃ pin input current 1	I _{V3}	V _{CELL} =3.5V			±300	nA
V ₃ pin input current 2	I _{V3A}	V _{CELL} =4.4V	-0.6	-0.3	0	μA
V ₂ pin input current 1	I _{V2}	V _{CELL} =3.5V			±300	nA
V ₂ pin input current 2	I _{V2A}	V _{CELL} =4.4V	-0.6	-0.3	0	μA
V ₁ pin input current 1	I _{V1}	V _{CELL} =3.5V			±300	nA
V ₁ pin input current 2	I _{V1A}	V _{CELL} =4.4V	-0.6	-0.3	0	μA
Overcharge detection voltage	V _{CELLU}	Ta=-20~+70°C, V _{CELL} : 3.7V→4.5V	4.20	4.25	4.30	V
Overcharge detection release voltage	V _{CELL0}	V _{CELL} : 4.5V→3.7V	V _{CELLU} -260mV	V _{CELLU} -200mV	V _{CELLU} -140mV	V
Overcharge sensing dead time	t _{OV}	C _{OV} =0.1μF	0.5	1.0	1.5	S
Overcharge sensing operation voltage	V _{ALM}	V _{CELL} : 3.5V→4.4V	3.95	4.10	4.25	V
Overdischarge sensing hysteresis voltage	ΔV _{ALM}	V _{CELL} : 4.4V→3.5V	130	230	330	mV
Overdischarge detection voltage	V _{CELLS}	V _{CELL} : 3.5V→2.0V	2.30	2.40	2.50	V
Discharge resume voltage	V _{CELLD}	V _{CELL} : 2.0V→3.5V	2.95	3.10	3.25	V
Overdischarge sensing hysteresis voltage	ΔV _{CS} D	V _{CELLD} -V _{CELLS}	490	700	910	mV
Overdischarge sensing dead time	t _{DC1}	C _{DC} =0.1μF	0.5	1.0	1.5	S
Overdischarge reset dead time	t _{DC2}	C _{DC} =0.1μF, V _{CS} =V _{CC} +0.3V		7		mS
Overcurrent detection voltage	V _{OC}	V _{CC} -V _{CS} , D _{CHG}	0.135	0.150	0.165	V
Overcurrent sensing dead time	t _{COL1}	C _{COL} =0.001μF, D _{CHG}	5	10	15	mS
Overcurrent reset dead time	t _{COL2}	C _{COL} =0.001μF, D _{CHG}	5	10	15	mS
Overcurrent sensing delay time	t _{COL3}	C _{COL} =0, D _{CHG}		150		μS
Overcurrent reset delay time	t _{COL4}	C _{COL} =0, D _{CHG}		150		μS
Overcurrent protection release			Open-load condition 300 kΩ			
DCHG pin source current	I _{SO} DCH	V _{CELL} < V _{CELLS} , SW1 : A, V _{DCHG} =V _{CC} -1.8V	20			μA
DCHG pin sync current	I _{SI} DCH	V _{CELL} > V _{CELLS} , SW1 : A, V _{DCHG} =0.8V	20			μA
DCHG pin output voltage H	V _{TH} DcH	V _{CC} -V _{DCHG} , I _{SO} =20μA, SW1 : B			1.8	V
DCHG pin output voltage L	V _{TH} DcL	V _{DCHG} -GND, I _{SI} =-20μA, SW1 : B			0.8	V
OV pin sync current	I _{SI} OV	V _{OV} =0.4V, Ta=-20~+70°C	0.2			mA
PF pin sync current	I _{SI} PF	V _{PF} =0.4V, Ta=-20~+70°C	10			μA

Timing Chart

Overcharge

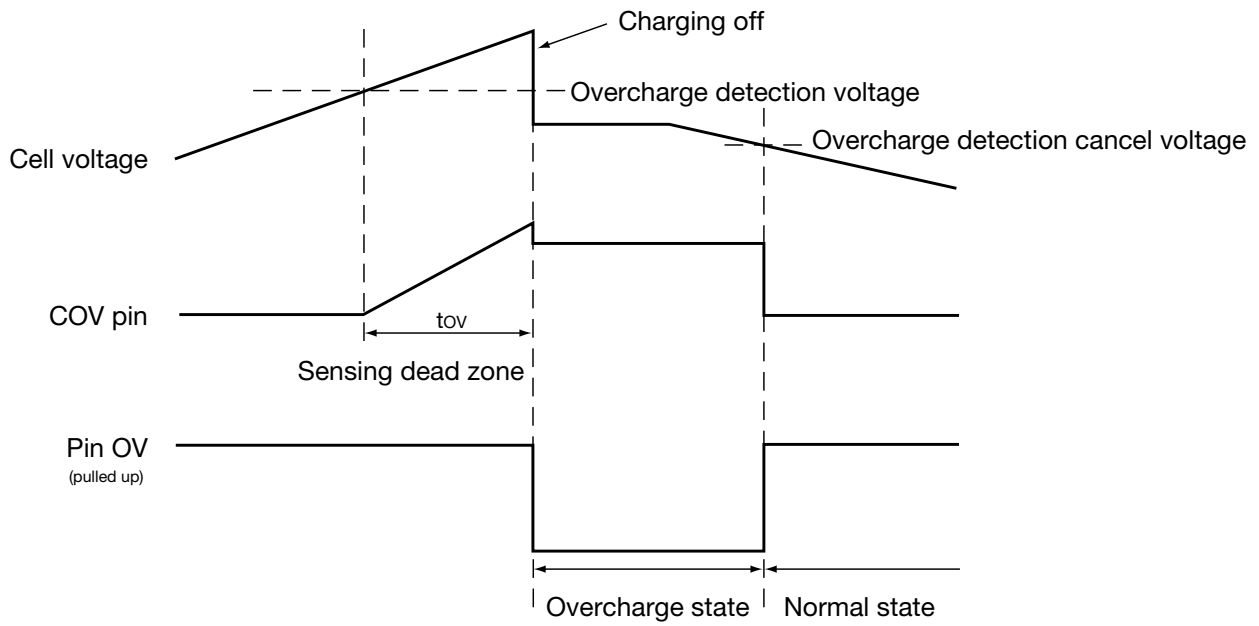

Overdischarge

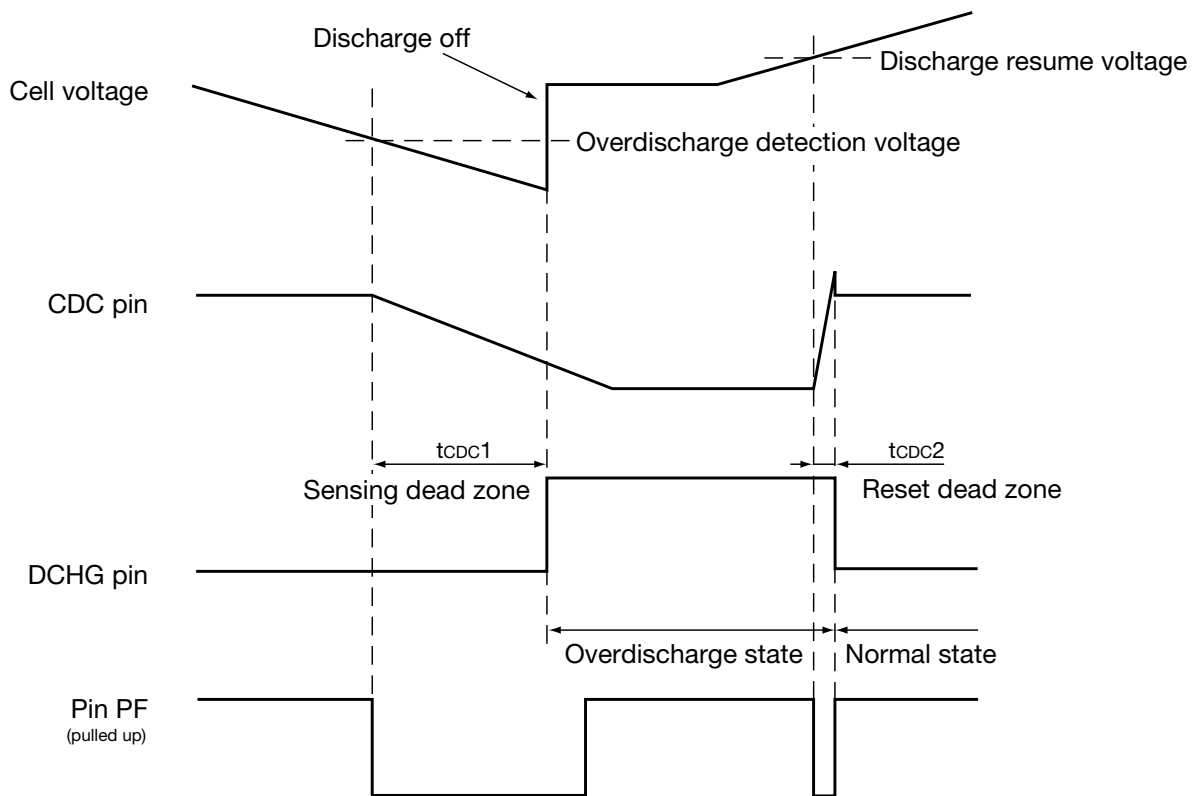

Application circuits

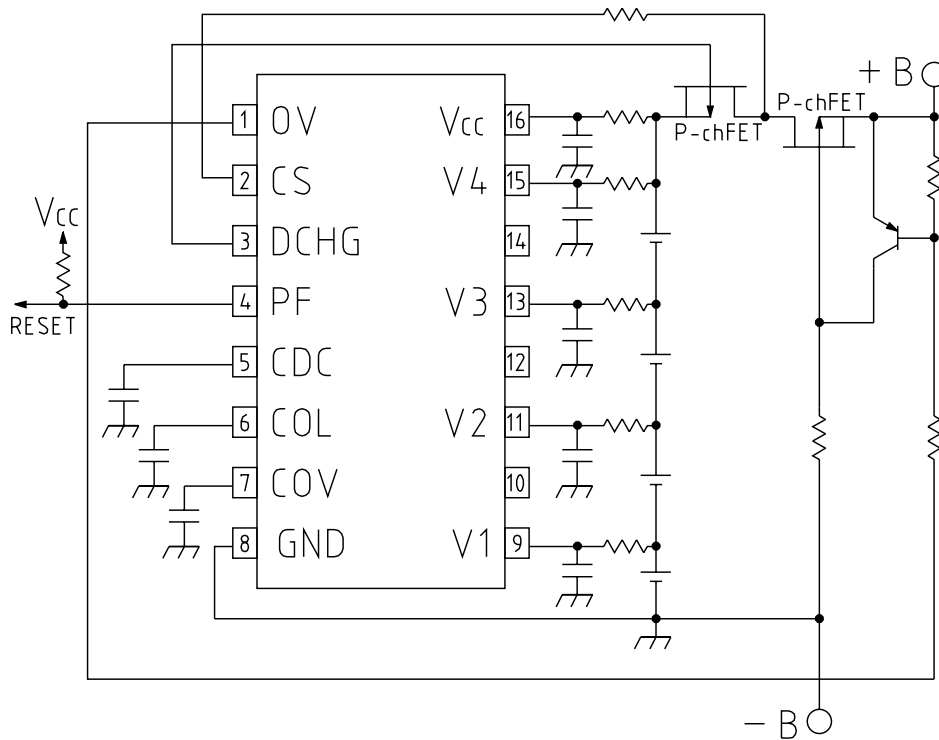

Note: Applicable circuits shown are typical examples provided for reference purposes. Mitsumi cannot assume responsibility for any problems arising out of the use of these circuits or for any infringement of third party patent and other right due to same.

Characteristics

Overcharge, overdischarge sensing dead

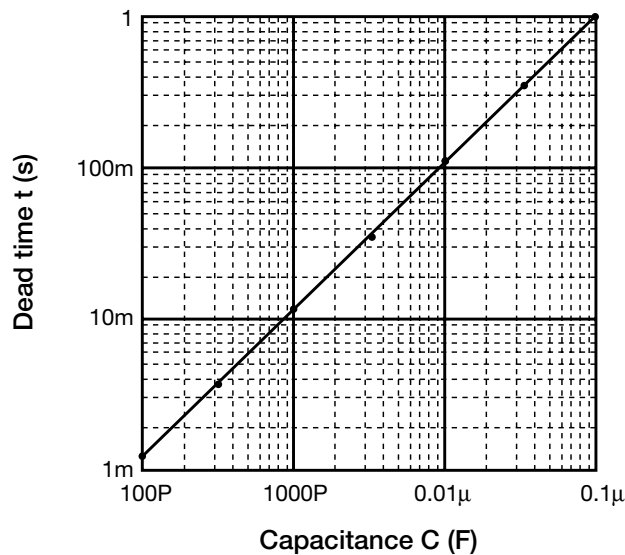

Note : The above characteristics are representative and are not guaranteed.