



Cold-Junction-Compensated K-Thermocouple-to-Digital Converter (0°C to +1024°C)

MAX6675

General Description

The MAX6675 performs cold-junction compensation and digitizes the signal from a type-K thermocouple. The data is output in a 12-bit resolution, SPI™-compatible, read-only format.

This converter resolves temperatures to 0.25°C, allows readings as high as +1024°C, and exhibits thermocouple accuracy of 8LSBs for temperatures ranging from 0°C to +700°C.

The MAX6675 is available in a small, 8-pin SO package.

Features

- ◆ Cold-Junction Compensation
- ◆ Simple SPI-Compatible Serial Interface
- ◆ 12-Bit, 0.25°C Resolution
- ◆ Open Thermocouple Detection

Ordering Information

PART	TEMP. RANGE	PIN-PACKAGE
MAX6675ISA	-20°C to +85°C	8 SO

Applications

Industrial
Appliances
HVAC
Automotive

Pin Configuration

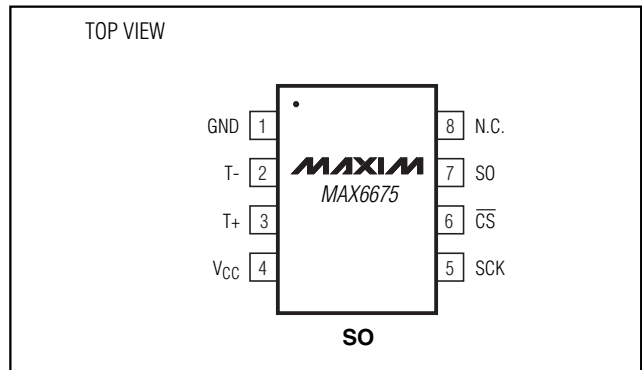

SPI is a trademark of Motorola, Inc.

Typical Application Circuit

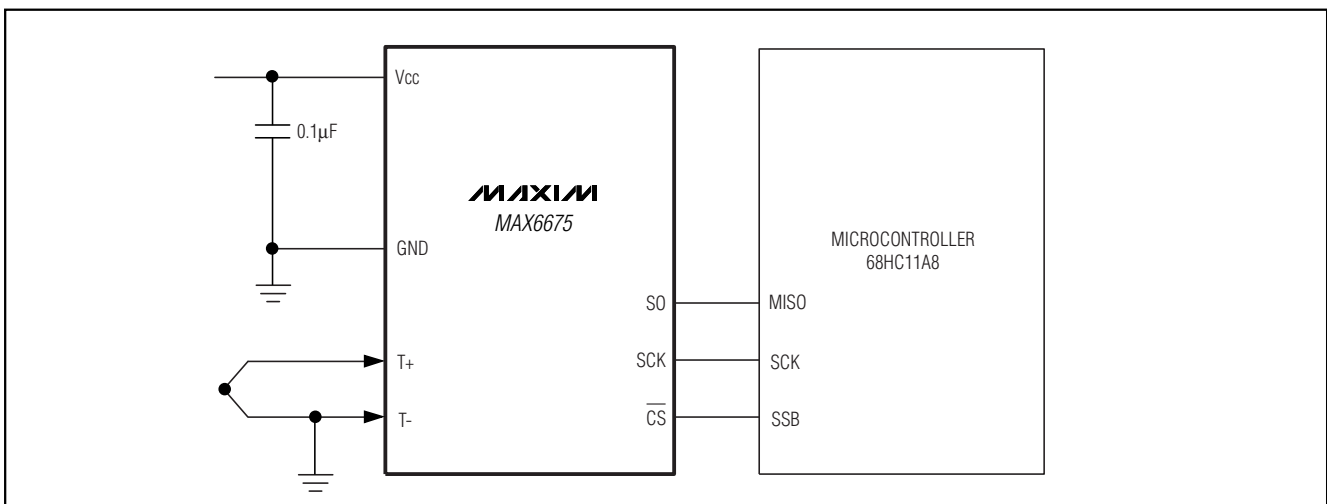

Cold-Junction-Compensated K-Thermocouple-to-Digital Converter (0°C to +1024°C)

ABSOLUTE MAXIMUM RATINGS

Supply Voltage (V_{CC} to GND) -0.3V to +6V
 SO, SCK, \overline{CS} , T-, T+ to GND -0.3V to V_{CC} + 0.3V
 SO Current 50mA
 ESD Protection (Human Body Model) ±2000V
 Continuous Power Dissipation (T_A = +70°C)
 8-Pin SO (derate 5.88mW/°C above +70°C) 471mW
 Operating Temperature Range -20°C to +85°C

Storage Temperature Range -65°C to +150°C
 Junction Temperature +150°C
 SO Package
 Vapor Phase (60s) +215°C
 Infrared (15s) +220°C
 Lead Temperature (soldering, 10s) +300°C

Stresses beyond those listed under "Absolute Maximum Ratings" may cause permanent damage to the device. These are stress ratings only, and functional operation of the device at these or any other conditions beyond those indicated in the operational sections of the specifications is not implied. Exposure to absolute maximum rating conditions for extended periods may affect device reliability.

ELECTRICAL CHARACTERISTICS

(V_{CC} = +3.0V to +5.5V, T_A = -20°C to +85°C, unless otherwise noted. Typical values specified at +25°C.) (Note 1)

PARAMETER	SYMBOL	CONDITIONS		MIN	TYP	MAX	UNITS
Temperature Error		T _{THERMOCOUPLE} = +700°C, T _A = +25°C (Note 2)	V _{CC} = +3.3V	-5		+5	LSB
			V _{CC} = +5V	-6		+6	
		T _{THERMOCOUPLE} = 0°C to +700°C, T _A = +25°C (Note 2)	V _{CC} = +3.3V	-8		+8	
			V _{CC} = +5V	-9		+9	
Thermocouple Conversion Constant			V _{CC} = +3.3V	-17		+17	μV/LSB
			V _{CC} = +5V	-19		+19	
Thermocouple Conversion Constant				10.25			μV/LSB
Cold-Junction Compensation		T _A = -20°C to +85°C (Note 2)	V _{CC} = +3.3V	-3.0		+3.0	°C
			V _{CC} = +5V	-3.0		+3.0	
Resolution				0.25			°C
Thermocouple Input Impedance				60			kΩ
Supply Voltage	V _{CC}			3.0		5.5	V
Supply Current	I _{CC}				0.7	1.5	mA
Power-On Reset Threshold		V _{CC} rising		1	2	2.5	V
Power-On Reset Hysteresis					50		mV
Conversion Time		(Note 2)			0.17	0.22	s
SERIAL INTERFACE							
Input Low Voltage	V _{IL}					0.3 x V _{CC}	V
Input High Voltage	V _{IH}			0.7 x V _{CC}			V
Input Leakage Current	I _{LEAK}	V _{IN} = GND or V _{CC}				±5	μA
Input Capacitance	C _{IN}				5		pF

Cold-Junction-Compensated K-Thermocouple-to-Digital Converter (0°C to +1024°C)

MAX6675

ELECTRICAL CHARACTERISTICS (continued)

(V_{CC} = +3.0V to +5.5V, T_A = -20°C to +85°C, unless otherwise noted. Typical values specified at +25°C.) (Note 1)

PARAMETER	SYMBOL	CONDITIONS	MIN	TYP	MAX	UNITS
Output High Voltage	V _{OH}	I _{SOURCE} = 1.6mA	V _{CC} - 0.4			V
Output Low Voltage	V _{OL}	I _{SINK} = 1.6mA			0.4	V
TIMING						
Serial Clock Frequency	f _{SCL}				4.3	MHz
SCK Pulse High Width	t _{CH}		100			ns
SCK Pulse Low Width	t _{CL}		100			ns
CSB Fall to SCK Rise	t _{CSS}	C _L = 10pF	100			ns
CSB Fall to Output Enable	t _{DV}	C _L = 10pF			100	ns
CSB Rise to Output Disable	t _{TR}	C _L = 10pF			100	ns
SCK Fall to Output Data Valid	t _{DO}	C _L = 10pF			100	ns

Note 1: All specifications are 100% tested at T_A = +25°C. Specification limits over temperature (T_A = T_{MIN} to T_{MAX}) are guaranteed by design and characterization, not production tested.

Note 2: Guaranteed by design. Not production tested.

Typical Operating Characteristics

(V_{CC} = +3.3V, T_A = +25°C, unless otherwise noted.)

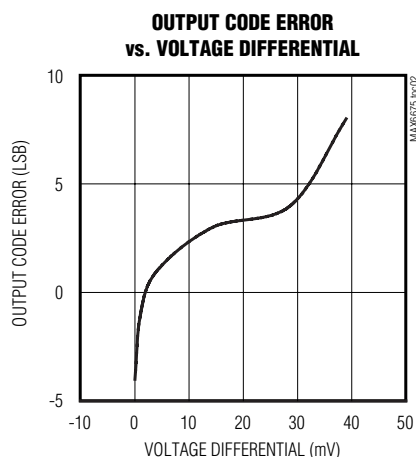
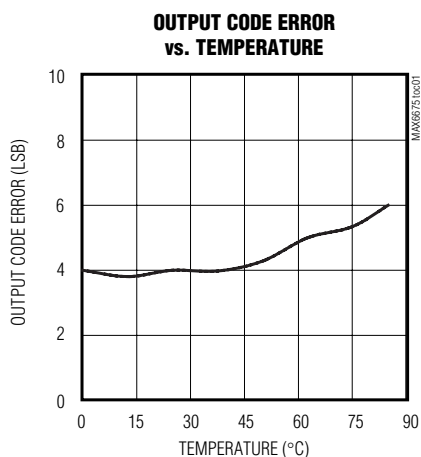

Cold-Junction-Compensated K-Thermocouple-to-Digital Converter (0°C to +1024°C)

Pin Description

PIN	NAME	FUNCTION
1	GND	Ground
2	T-	Iron Lead of Type-K Thermocouple. Should be connected to ground externally.
3	T+	Constantan Lead of Type-K Thermocouple
4	V _{CC}	Positive Supply. Bypass with a 0.1μF capacitor to GND.
5	SCK	Serial Clock Input
6	$\overline{\text{CS}}$	Chip Select. Set $\overline{\text{CS}}$ low to enable the serial interface.
7	SO	Serial Data Output
8	N.C.	No Connection

Detailed Description

The MAX6675 is a sophisticated thermocouple-to-digital converter with a built-in 12-bit analog-to-digital converter (ADC). The MAX6675 also contains cold-junction compensation sensing and correction, a digital controller, an SPI-compatible interface, and associated control logic.

The MAX6675 is designed to work in conjunction with an external microcontroller (μC) or other intelligence in thermostatic, process-control, or monitoring applications. The μC is typically a power-management or keyboard controller, generating SPI serial commands by “bit-banging” general-purpose input-output (GPIO) pins or through a dedicated SPI interface block.

Temperature Conversion

The MAX6675 includes signal-conditioning hardware to convert the thermocouple’s signal into a voltage compatible with the input channels of the ADC. The T+ and T- inputs connect to internal circuitry that reduces the introduction of noise errors from the thermocouple wires.

Before converting the thermoelectric voltages into equivalent temperature values, it is necessary to compensate for the difference between the thermocouple cold-junction side (MAX6675 ambient temperature) and a 0°C virtual reference. For a type-K thermocouple, the voltage changes by 41μV/°C, which approximates the

thermocouple characteristic with the following linear equation:

$$V_{\text{OUT}} = (41\mu\text{V} / ^\circ\text{C}) \times (T_{\text{R}} - T_{\text{AMB}})$$

Where:

V_{OUT} is the thermocouple output voltage (μV).

T_R is the temperature of the remote point (°C).

T_{AMB} is the ambient temperature (°C).

Cold-Junction Compensation

The function of the thermocouple is to sense a difference in temperature between two ends. The thermocouple’s hot junction can be read from 0°C to +1023.75°C. The cold end (ambient temperature of the board on which the MAX6675 is mounted) can only range from -20°C to +85°C. While the temperature at the cold end fluctuates, the MAX6675 continues to accurately sense the temperature difference at the opposite end.

The MAX6675 senses and corrects for the changes in the ambient temperature with cold-junction compensation. The device converts the ambient temperature reading into a voltage using a temperature-sensing diode. To make the actual thermocouple temperature measurement, the MAX6675 measures the voltage from the thermocouple’s output and from the sensing diode. The device’s internal circuitry passes the diode’s voltage (sensing ambient temperature) and thermocouple voltage (sensing remote temperature minus ambient temperature) to the conversion function stored in the ADC to calculate the thermocouple’s hot-junction temperature.

Optimal performance from the MAX6675 is achieved when the thermocouple cold junction and the device are at the same temperature. Avoid placing heat-generating devices or components near the MAX6675 because this may produce cold-junction-related errors.

Digitization

The ADC adds the cold-junction diode measurement with the amplified thermocouple voltage and reads out the 12-bit sequence onto the SO pin. A sequence of all zeros means the thermocouple reading is 0°C. A sequence of all ones means the thermocouple reading is +1023.75°C.

Cold-Junction-Compensated K-Thermocouple-to-Digital Converter (0°C to +1024°C)

Applications Information

Serial Interface

The *Typical Application Circuit* shows the MAX6675 interfaced with a microcontroller. In this example, the MAX6675 processes the reading from the thermocouple and transmits the data through a serial interface. Force \overline{CS} low and apply a clock signal at SCK to read the results at SO. Forcing \overline{CS} low immediately stops any conversion process. Initiate a new conversion process by forcing \overline{CS} high.

Force \overline{CS} low to output the first bit on the SO pin. A complete serial interface read requires 16 clock cycles. Read the 16 output bits on the falling edge of the clock. The first bit, D15, is a dummy sign bit and is always zero. Bits D14–D3 contain the converted temperature in the order of MSB to LSB. Bit D2 is normally low and goes high when the thermocouple input is open. D1 is low to provide a device ID for the MAX6675 and bit D0 is three-state.

Figure 1a is the serial interface protocol and Figure 1b shows the serial interface timing. Figure 2 is the SO output.

Open Thermocouple

Bit D2 is normally low and goes high if the thermocouple input is open. The open thermocouple detection circuit is implemented completely into the MAX6675. In order to allow the operation of the open thermocouple detector, T- must be grounded. Make the ground connection as close to the GND pin as possible.

Noise Considerations

The accuracy of the MAX6675 is susceptible to power-supply coupled noise. The effects of power-supply noise can be minimized by placing a 0.1µF ceramic bypass capacitor close to the supply pin of the device.

Thermal Considerations

Self-heating degrades the temperature measurement accuracy of the MAX6675 in some applications. The magnitude of the temperature errors depends on the

thermal conductivity of the MAX6675 package, the mounting technique, and the effects of airflow. Use a large ground plane to improve the temperature measurement accuracy of the MAX6675.

The accuracy of a thermocouple system can also be improved by following these precautions:

- Use the largest wire possible that does not shunt heat away from the measurement area.
- If small wire is required, use it only in the region of the measurement and use extension wire for the region with no temperature gradient.
- Avoid mechanical stress and vibration, which could strain the wires.
- When using long thermocouple wires, use a twisted-pair extension wire.
- Avoid steep temperature gradients.
- Try to use the thermocouple wire well within its temperature rating.
- Use the proper sheathing material in hostile environments to protect the thermocouple wire.
- Use extension wire only at low temperatures and only in regions of small gradients.
- Keep an event log and a continuous record of thermocouple resistance.

Reducing Effects of Pick-Up Noise

The input amplifier (A1) is a low-noise amplifier designed to enable high-precision input sensing. Keep the thermocouple and connecting wires away from electrical noise sources.

Chip Information

TRANSISTOR COUNT: 6720

PROCESS: BiCMOS

Cold-Junction-Compensated K-Thermocouple-to-Digital Converter (0°C to +1024°C)

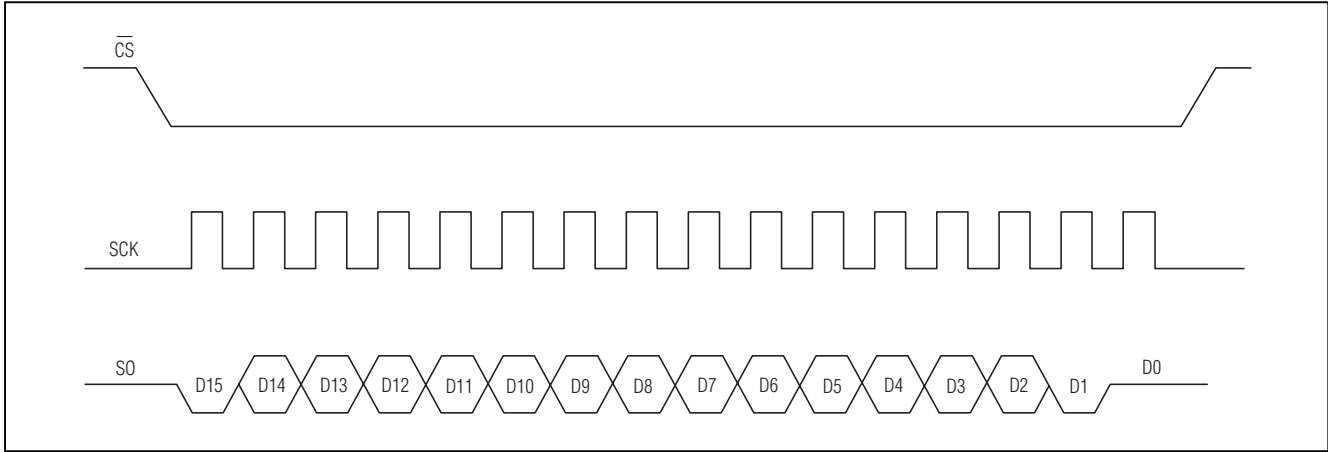

Figure 1a. Serial Interface Protocol

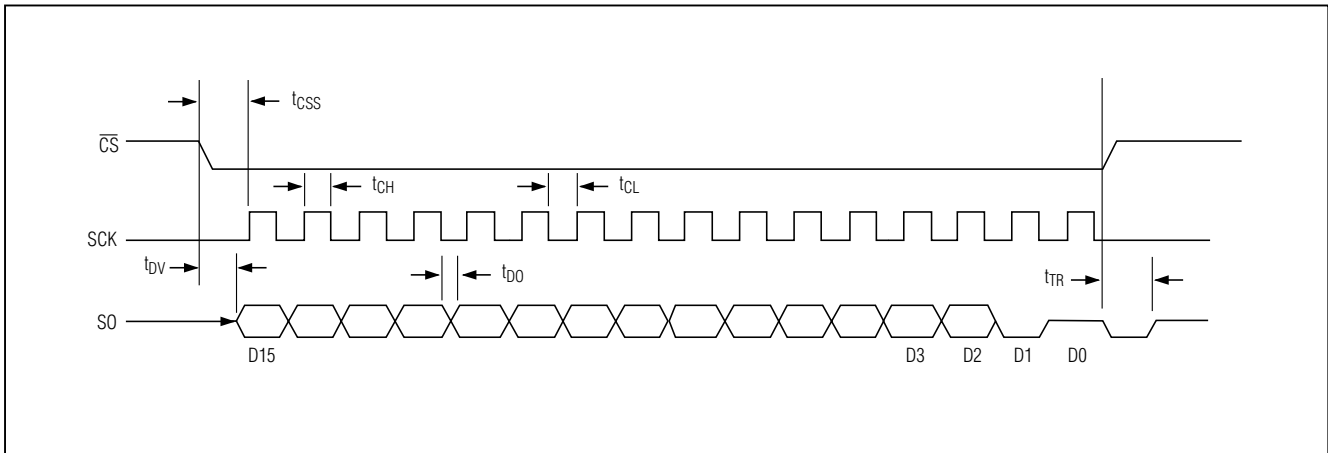

Figure 1b. Serial Interface Timing

BIT	DUMMY SIGN BIT	12-BIT TEMPERATURE READING											THERMOCOUPLE INPUT	DEVICE ID	STATE	
		14	13	12	11	10	9	8	7	6	5	4				3
Bit	15													2	1	0
	0	MSB											LSB		0	Three-state

Figure 2. SO Output

Cold-Junction-Compensated K-Thermocouple-to-Digital Converter (0°C to +1024°C)

Block Diagram

MAX6675

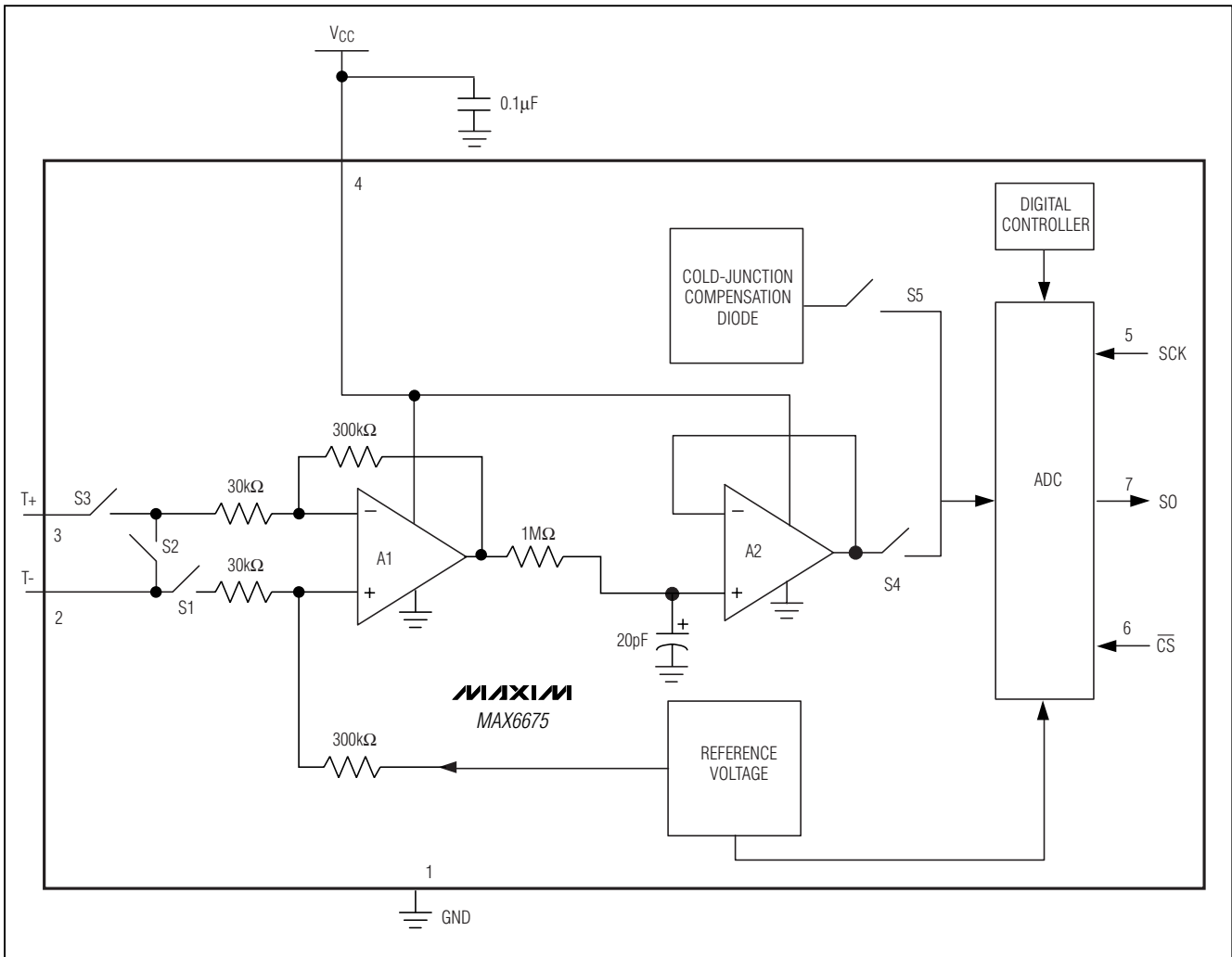

Cold-Junction-Compensated K-Thermocouple-to-Digital Converter (0°C to +1024°C)

Package Information

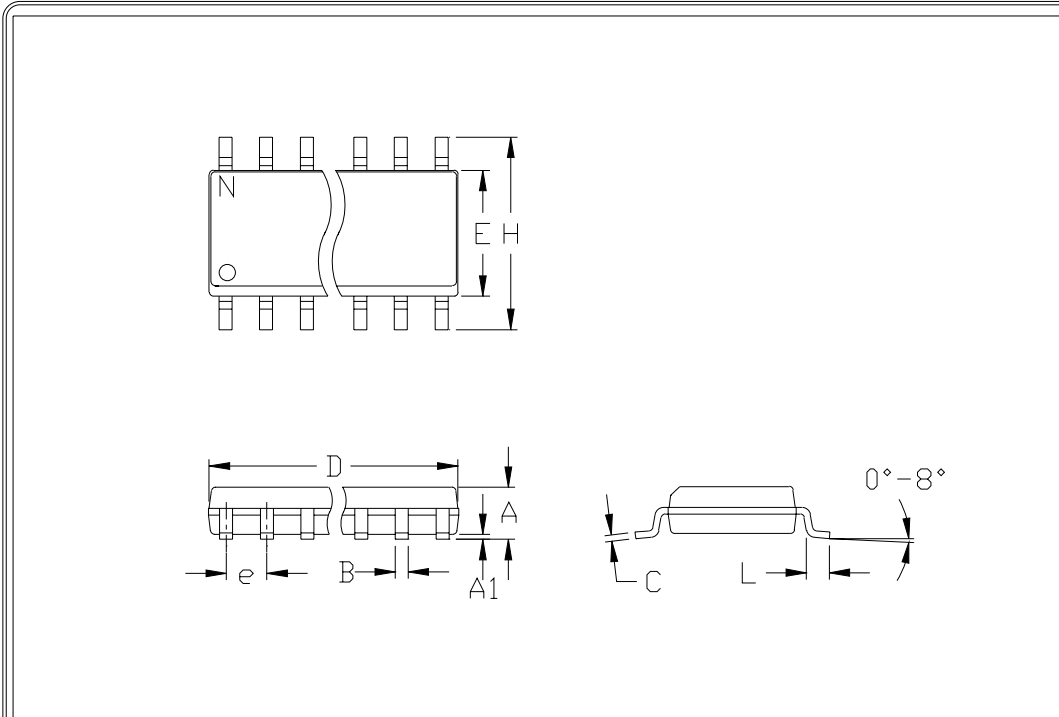

	INCHES		MILLIMETERS	
	MIN	MAX	MIN	MAX
A	0.053	0.069	1.35	1.75
A1	0.004	0.010	0.10	0.25
B	0.014	0.019	0.35	0.49
C	0.007	0.010	0.19	0.25
e	0.050		1.27	
E	0.150	0.157	3.80	4.00
H	0.228	0.244	5.80	6.20
h	0.010	0.020	0.25	0.50
L	0.016	0.050	0.40	1.27

	INCHES		MILLIMETERS		N	MS012
	MIN	MAX	MIN	MAX		
D	0.189	0.197	4.80	5.00	8	A
D	0.337	0.344	8.55	8.75	14	B
D	0.386	0.394	9.80	10.00	16	C

NOTES:

1. D&E DO NOT INCLUDE MOLD FLASH
2. MOLD FLASH OR PROTRUSIONS NOT TO EXCEED .15mm (.006")
3. LEADS TO BE COPLANAR WITHIN .102mm (.004")
4. CONTROLLING DIMENSION: MILLIMETER
5. MEETS JEDEC MS012-XX AS SHOWN IN ABOVE TABLE
6. N = NUMBER OF PINS

 <small>120 SAN GABRIEL DR. SUNNYVALE, CA 94086 FAX (408) 737 7154</small> <small>PROPRIETARY INFORMATION</small>	PACKAGE FAMILY OUTLINE: SOIC .150"		21-0041 A
			<small>DOCUMENT CONTROL NUMBER REV</small>

Maxim cannot assume responsibility for use of any circuitry other than circuitry entirely embodied in a Maxim product. No circuit patent licenses are implied. Maxim reserves the right to change the circuitry and specifications without notice at any time.

8 Maxim Integrated Products, 120 San Gabriel Drive, Sunnyvale, CA 94086 408-737-7600