

TOSHIBA CMOS DIGITAL INTEGRATED CIRCUIT SILICON MONOLITHIC

**TC74ACT153P, TC74ACT153F, TC74ACT153FN**

**DUAL 4 - CHANNEL MULTIPLEXER**

The TC74ACT153 is an advanced high speed CMOS DUAL 4 - CHANNEL MULTIPLEXERS fabricated with silicon gate and double - layer metal wiring C<sup>2</sup>MOS technology. They achieve the high speed operation similar to equivalent Bipolar Schottky TTL while maintaining the CMOS low power dissipations.

This device may be used as a level converter for interfacing TTL or NMOS to High Speed CMOS. The inputs are compatible with TTL, NMOS and CMOS output voltage levels.

Each of these data (1C0 - 1C3, 2C0 - 2C3) is selected by the two address inputs A and B.

Separate strobe inputs (1G, 2G) are provided for each of the two four - line sections.

The strobe input can be used to inhibit the data output; the output is fixed in low level unconditionally.

All inputs are equipped with protection circuits against static discharge or transient excess voltage.

**FEATURES :**

- High Speed.....  $t_{pd} = 5.4ns(typ.)$  at  $V_{CC} = 5V$
- Low Power Dissipation.....  $I_{CC} = 8\mu A(Max.)$  at  $T_a = 25^\circ C$
- Compatible with TTL outputs ...  $V_{IL} = 0.8V (Max.)$   
 $V_{IH} = 2.0V (Min.)$
- Symmetrical Output Impedance...  $|I_{OH}| = I_{OL} = 24mA (Min.)$   
Capability of driving 50Ω transmission lines.
- Balanced Propagation Delays.....  $t_{pLH} \approx t_{pHL}$
- Pin and Function Compatible with 74F153

(Note) The JEDEC SOP (FN) is not available in Japan.

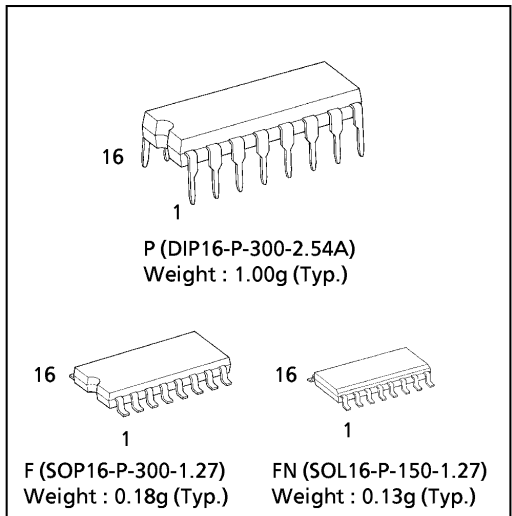

**PIN ASSIGNMENT**

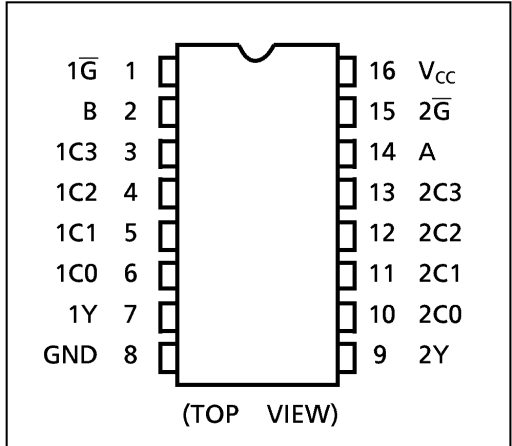

**TRUTH TABLE**

SELECT INPUTS		DATA INPUTS				STROBE	OUTPUT
B	A	C0	C1	C2	C3	$\bar{G}$	Y
X	X	X	X	X	X	H	L
L	L	L	X	X	X	L	L
L	L	H	X	X	X	L	H
L	H	X	L	X	X	L	L
L	H	X	H	X	X	L	H
H	L	X	X	L	X	L	L
H	L	X	X	H	X	L	H
H	H	X	X	X	L	L	L
H	H	X	X	X	H	L	H

X : Don't Care

**IEC LOGIC SYMBOL**

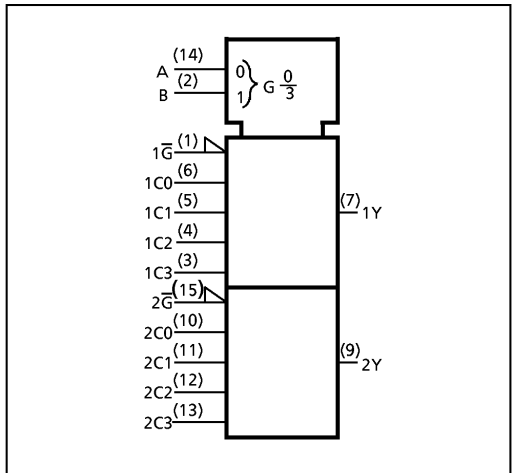

961001EBA2

● TOSHIBA is continually working to improve the quality and the reliability of its products. Nevertheless, semiconductor devices in general can malfunction or fail due to their inherent electrical sensitivity and vulnerability to physical stress. It is the responsibility of the buyer, when utilizing TOSHIBA products, to observe standards of safety, and to avoid situations in which a malfunction or failure of a TOSHIBA product could cause loss of human life, bodily injury or damage to property. In developing your designs, please ensure that TOSHIBA products are used within specified operating ranges as set forth in the most recent products specifications. Also, please keep in mind the precautions and conditions set forth in the TOSHIBA Semiconductor Reliability Handbook.

SYSTEM DIAGRAM

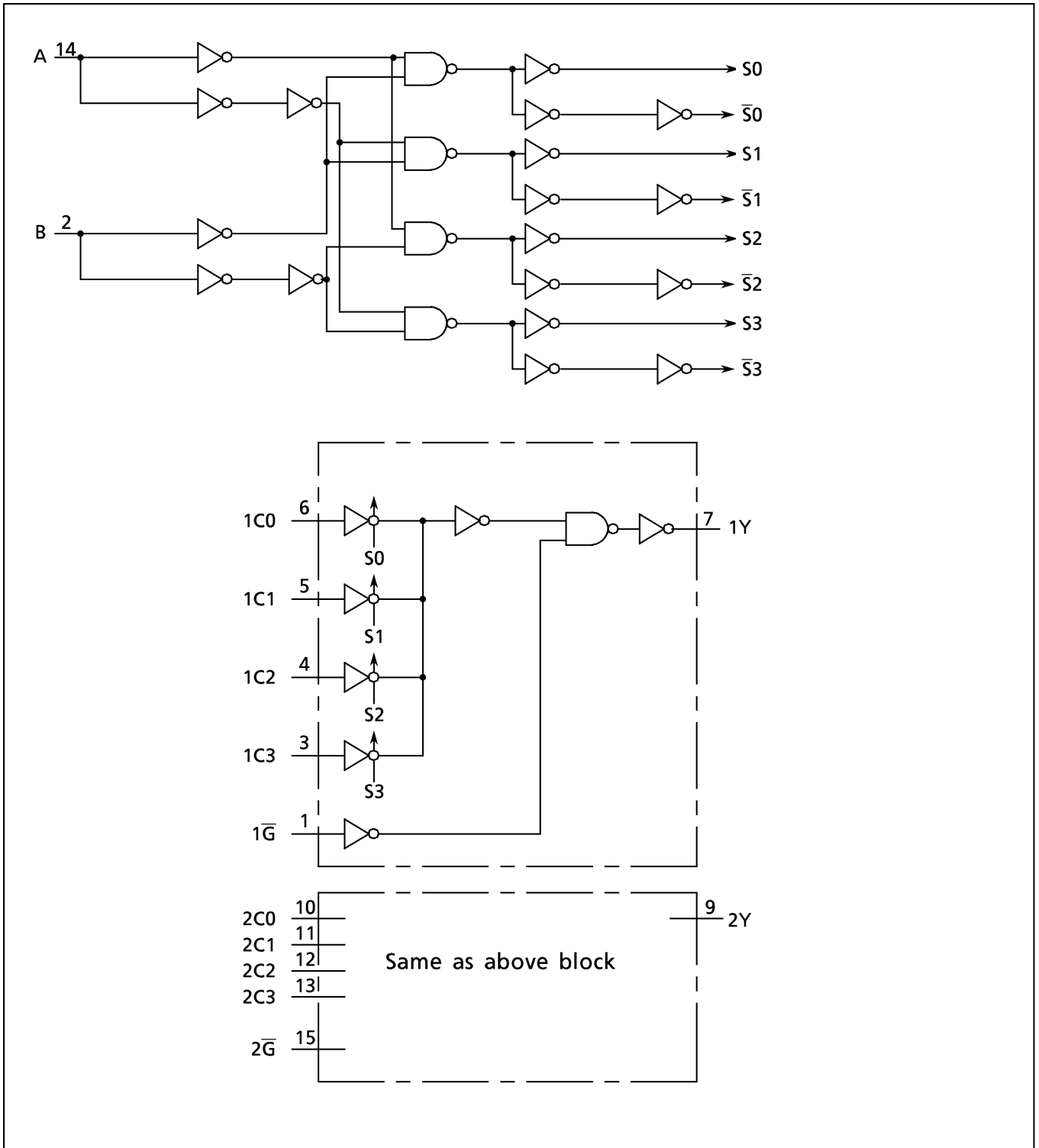

961001EBA2'

- The products described in this document are subject to foreign exchange and foreign trade control laws.
- The information contained herein is presented only as a guide for the applications of our products. No responsibility is assumed by TOSHIBA CORPORATION for any infringements of intellectual property or other rights of the third parties which may result from its use. No license is granted by implication or otherwise under any intellectual property or other rights of TOSHIBA CORPORATION or others.
- The information contained herein is subject to change without notice.

**ABSOLUTE MAXIMUM RATINGS**

PARAMETER	SYMBOL	VALUE	UNIT
Supply Voltage Range	$V_{CC}$	-0.5~7.0	V
DC Input Voltage	$V_{IN}$	-0.5~ $V_{CC} + 0.5$	V
DC Output Voltage	$V_{OUT}$	-0.5~ $V_{CC} + 0.5$	V
Input Diode Current	$I_{IK}$	± 20	mA
Output Diode Current	$I_{OK}$	± 50	mA
DC Output Current	$I_{OUT}$	± 50	mA
DC $V_{CC}$ /Ground Current	$I_{CC}$	± 100	mA
Power Dissipation	$P_D$	500 (DIP)* / 180 (SOP)	mW
Storage Temperature	$T_{stg}$	-65~150	°C

\*500mW in the range of  $T_a = -40^{\circ}\text{C} \sim 65^{\circ}\text{C}$ . From  $T_a = 65^{\circ}\text{C}$  to  $85^{\circ}\text{C}$  a derating factor of  $-10\text{mW}/^{\circ}\text{C}$  should be applied up to 300mW.

**RECOMMENDED OPERATING CONDITIONS**

PARAMETER	SYMBOL	VALUE	UNIT
Supply Voltage	$V_{CC}$	4.5~5.5	V
Input Voltage	$V_{IN}$	0~ $V_{CC}$	V
Output Voltage	$V_{OUT}$	0~ $V_{CC}$	V
Operating Temperature	$T_{opr}$	-40~85	°C
Input Rise and Fall Time	$dt/dV$	0~10	ns/V

**DC ELECTRICAL CHARACTERISTICS**

PARAMETER	SYMBOL	TEST CONDITION	$V_{CC}$ (V)	$T_a = 25^{\circ}\text{C}$			$T_a = -40 \sim 85^{\circ}\text{C}$		UNIT	
				MIN.	TYP.	MAX.	MIN.	MAX.		
High - Level Input Voltage	$V_{IH}$		4.5 ┆ 5.5	2.0	—	—	2.0	—	V	
Low - Level Input Voltage	$V_{IL}$		4.5 ┆ 5.5	—	—	0.8	—	0.8	V	
High - Level Output Voltage	$V_{OH}$	$V_{IN} = V_{IH}$ or $V_{IL}$	$I_{OH} = -50\mu\text{A}$	4.5	4.4	4.5	—	4.4	—	V
			$I_{OH} = -24\text{mA}$	4.5	3.94	—	3.80	—		
			$I_{OH} = -75\text{mA}^*$	5.5	—	—	3.85	—		
Low - Level Output Voltage	$V_{OL}$	$V_{IN} = V_{IH}$ or $V_{IL}$	$I_{OL} = 50\mu\text{A}$	4.5	—	0.0	0.1	—	0.1	V
			$I_{OL} = 24\text{mA}$	4.5	—	—	0.36	—	0.44	
			$I_{OL} = 75\text{mA}^*$	5.5	—	—	—	—	1.65	
Input Leakage Current	$I_{IN}$	$V_{IN} = V_{CC}$ or GND	5.5	—	—	± 0.1	—	± 1.0	$\mu\text{A}$	
Quiescent Supply Current	$I_{CC}$	$V_{IN} = V_{CC}$ or GND	5.5	—	—	8.0	—	80.0		
		$I_C$	PER INPUT : $V_{IN} = 3.4\text{V}$ OTHER INPUT : $V_{CC}$ or GND	5.5	—	—	1.35	—	1.5	mA

\* This spec indicates the capability of driving  $50\Omega$  transmission lines. One output should be tested at a time for a 10ms maximum duration.

AC ELECTRICAL CHARACTERISTICS (  $C_L = 50\text{pF}$ ,  $R_L = 500\Omega$ , Input  $t_r = t_f = 3\text{ns}$  )

PARAMETER	SYMBOL	TEST CONDITION	Ta = 25°C			Ta = -40~85°C		UNIT	
			V <sub>CC</sub> (V)	MIN.	TYP.	MAX.	MIN.		MAX.
Propagation Delay Time (Cn-Y)	t <sub>pLH</sub> t <sub>pHL</sub>		5.0 ± 0.5	—	6.1	9.7	1.0	11.0	ns
Propagation Delay Time (A, B-Y)	t <sub>pLH</sub> t <sub>pHL</sub>		5.0 ± 0.5	—	7.8	11.8	1.0	13.5	
Propagation Delay Time ( $\bar{G}$ -Y)	t <sub>pLH</sub> t <sub>pHL</sub>		5.0 ± 0.5	—	5.6	9.7	1.0	11.0	
Input Capacitance	C <sub>IN</sub>		—	—	5	10	—	10	pF
Power Dissipation Capacitance	C <sub>PD</sub> (1)		—	—	47	—	—	—	

Note (1) C<sub>PD</sub> is defined as the value of the internal equivalent capacitance which is calculated from the operating current consumption without load.

Average operating current can be obtained by the equation :

$$I_{CC}(\text{opr.}) = C_{PD} \cdot V_{CC} \cdot f_{IN} + I_{CC}$$

DIP 16PIN OUTLINE DRAWING (DIP16-P-300-2.54A)

Unit in mm

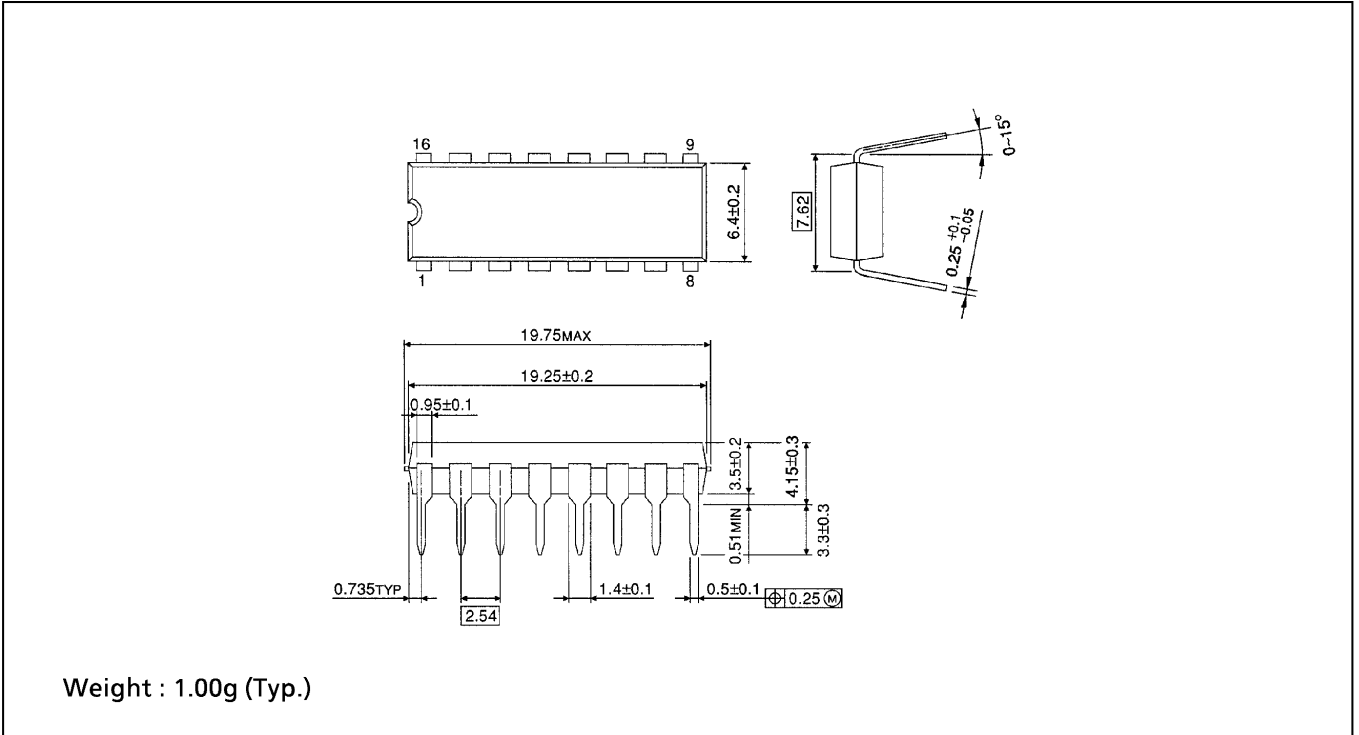

SOP 16PIN (200mil BODY) OUTLINE DRAWING (SOP16-P-300-1.27)

Unit in mm

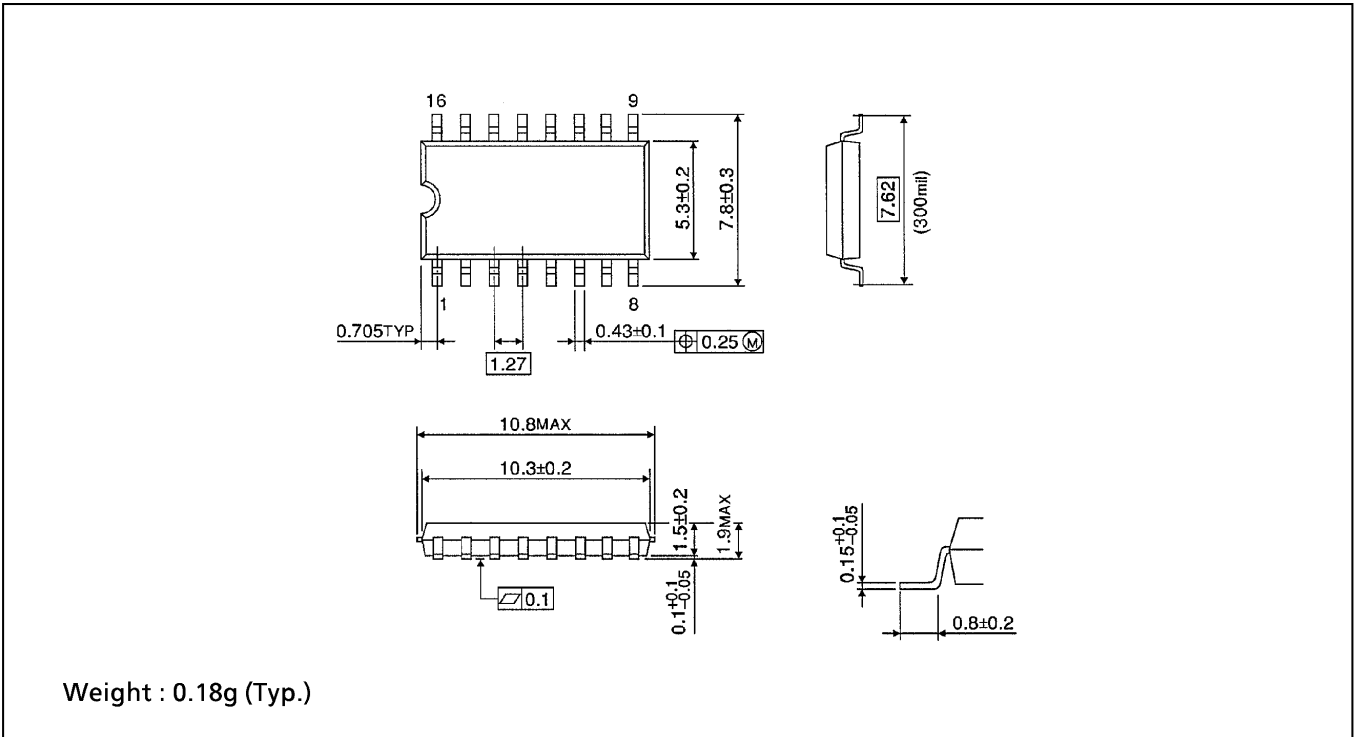

SOP 16PIN (150mil BODY) OUTLINE DRAWING (SOL16-P-150 -1.27)

Unit in mm

(Note) This package is not available in Japan.

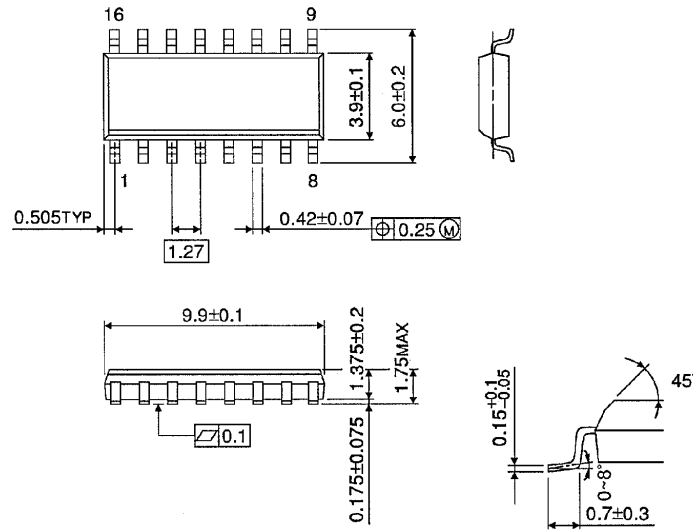

Weight : 0.13g (Typ.)