

Features

- Utilizes the AVR[®] RISC Architecture
- High-performance and Low-power 8-bit RISC Architecture
 - 90 Powerful Instructions – Most Single Clock Cycle Execution
 - 32 x 8 General Purpose Working Registers
 - Up to 8 MIPS Throughput at 8 MHz
- Nonvolatile Program and Data Memory
 - 1K Byte of Flash Program Memory
 - In-System Programmable (ATtiny12)
 - Endurance: 1,000 Write/Erase Cycles (ATtiny11/12)
 - 64 Bytes of In-System Programmable EEPROM Data Memory for ATtiny12
 - Endurance: 100,000 Write/Erase Cycles
 - Programming Lock for Flash Program and EEPROM Data Security
- Peripheral Features
 - Interrupt and Wake-up on Pin Change
 - One 8-bit Timer/Counter with Separate Prescaler
 - On-chip Analog Comparator
 - Programmable Watchdog Timer with On-chip Oscillator
- Special Microcontroller Features
 - Low-power Idle and Power-down Modes
 - External and Internal Interrupt Sources
 - In-System Programmable via SPI Port (ATtiny12)
 - Enhanced Power-on Reset Circuit (ATtiny12)
 - Internal Calibrated RC Oscillator (ATtiny12)
- Specification
 - Low-power, High-speed CMOS Process Technology
 - Fully Static Operation
- Power Consumption at 4 MHz, 3V, 25°C
 - Active: 2.2 mA
 - Idle Mode: 0.5 mA
 - Power-down Mode: <1 μA
- Packages
 - 8-pin PDIP and SOIC
- Operating Voltages
 - 1.8 - 5.5V for ATtiny12V-1
 - 2.7 - 5.5V for ATtiny11L-2 and ATtiny12L-4
 - 4.0 - 5.5V for ATtiny11-6 and ATtiny12-8
- Speed Grades
 - 0 - 1.2 MHz (ATtiny12V-1)
 - 0 - 2 MHz (ATtiny11L-2)
 - 0 - 4 MHz (ATtiny12L-4)
 - 0 - 6 MHz (ATtiny11-6)
 - 0 - 8 MHz (ATtiny12-8)

Pin Configuration

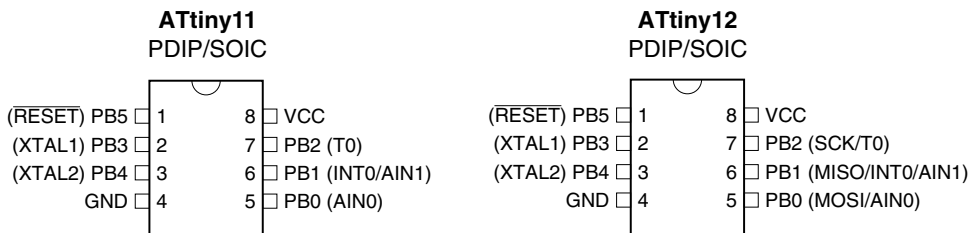

**8-bit AVR[®]
Microcontroller
with 1K Byte
Flash**

**ATtiny11
ATtiny12**





Description

The ATtiny11/12 is a low-power CMOS 8-bit microcontroller based on the AVR RISC architecture. By executing powerful instructions in a single clock cycle, the ATtiny11/12 achieves throughputs approaching 1 MIPS per MHz, allowing the system designer to optimize power consumption versus processing speed.

The AVR core combines a rich instruction set with 32 general-purpose working registers. All the 32 registers are directly connected to the Arithmetic Logic Unit (ALU), allowing two independent registers to be accessed in one single instruction executed in one clock cycle. The resulting architecture is more code efficient while achieving throughputs up to ten times faster than conventional CISC microcontrollers.

Table 1. Parts Description

Device	Flash	EEPROM	Register	Voltage Range	Frequency
ATtiny11L	1K	-	32	2.7 - 5.5V	0-2 MHz
ATtiny11	1K	-	32	4.0 - 5.5V	0-6 MHz
ATtiny12V	1K	64 B	32	1.8 - 5.5V	0-1.2 MHz
ATtiny12L	1K	64 B	32	2.7 - 5.5V	0-4 MHz
ATtiny12	1K	64 B	32	4.0 - 5.5V	0-8 MHz

ATtiny11 Block Diagram

The ATtiny11 provides the following features: 1K bytes of Flash, up to five general-purpose I/O lines, one input line, 32 general-purpose working registers, an 8-bit timer/counter, internal and external interrupts, programmable Watchdog Timer with internal oscillator, and two software-selectable power-saving modes. The Idle Mode stops the CPU while allowing the timer/counters and interrupt system to continue functioning. The Power-down Mode saves the register contents but freezes the oscillator, disabling all other chip functions until the next interrupt or hardware reset. The wake-up or interrupt on pin change features enable the ATtiny11 to be highly responsive to external events, still featuring the lowest power consumption while in the power-down modes.

The device is manufactured using Atmel's high-density nonvolatile memory technology. By combining an RISC 8-bit CPU with Flash on a monolithic chip, the Atmel ATtiny11 is a powerful microcontroller that provides a highly-flexible and cost-effective solution to many embedded control applications.

The ATtiny11 AVR is supported with a full suite of program and system development tools including: macro assemblers, program debugger/simulators, in-circuit emulators, and evaluation kits.

Figure 1. The ATtiny11 Block Diagram

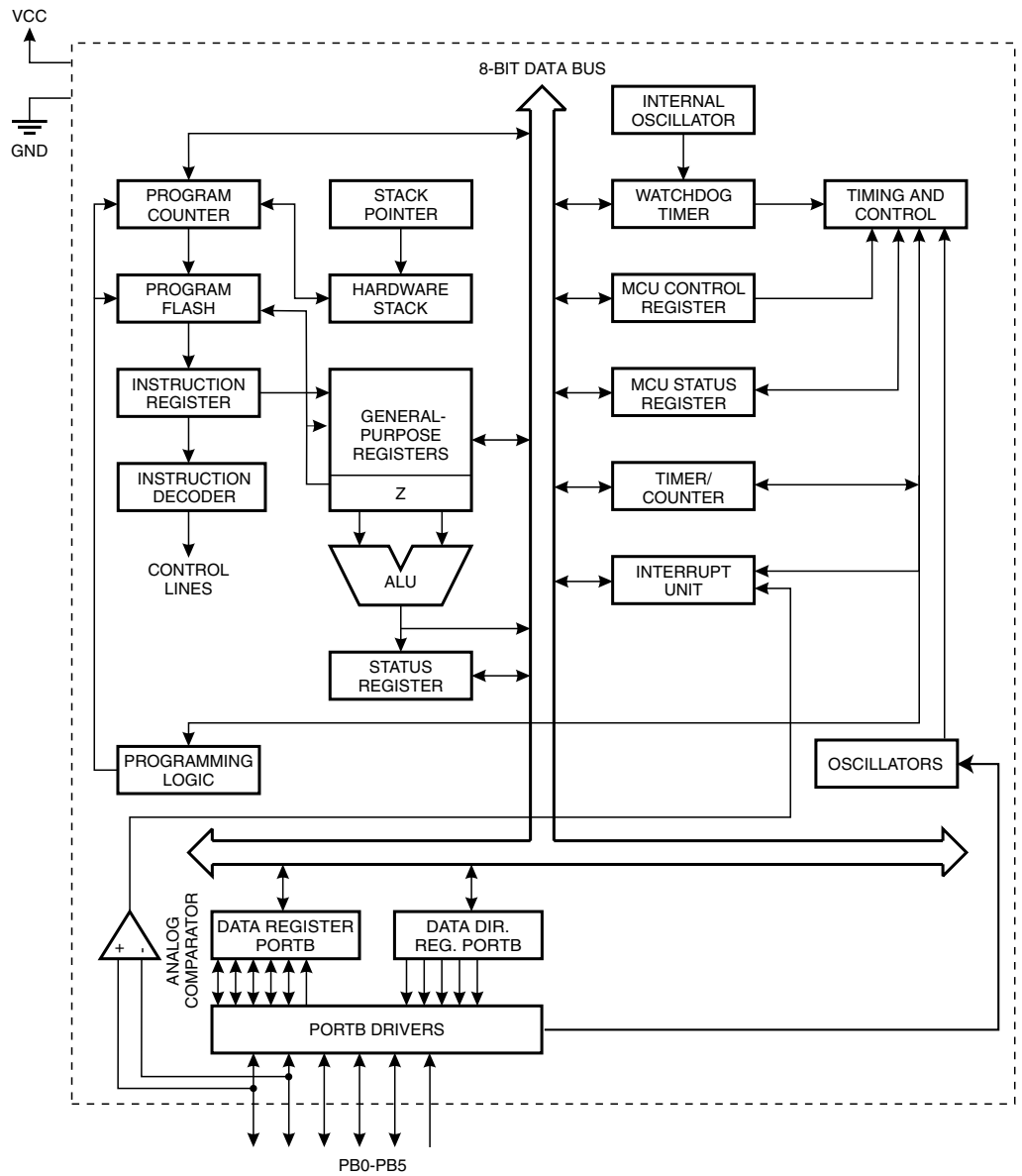

ATtiny12 Block Diagram

Figure 2. The ATtiny12 Block Diagram

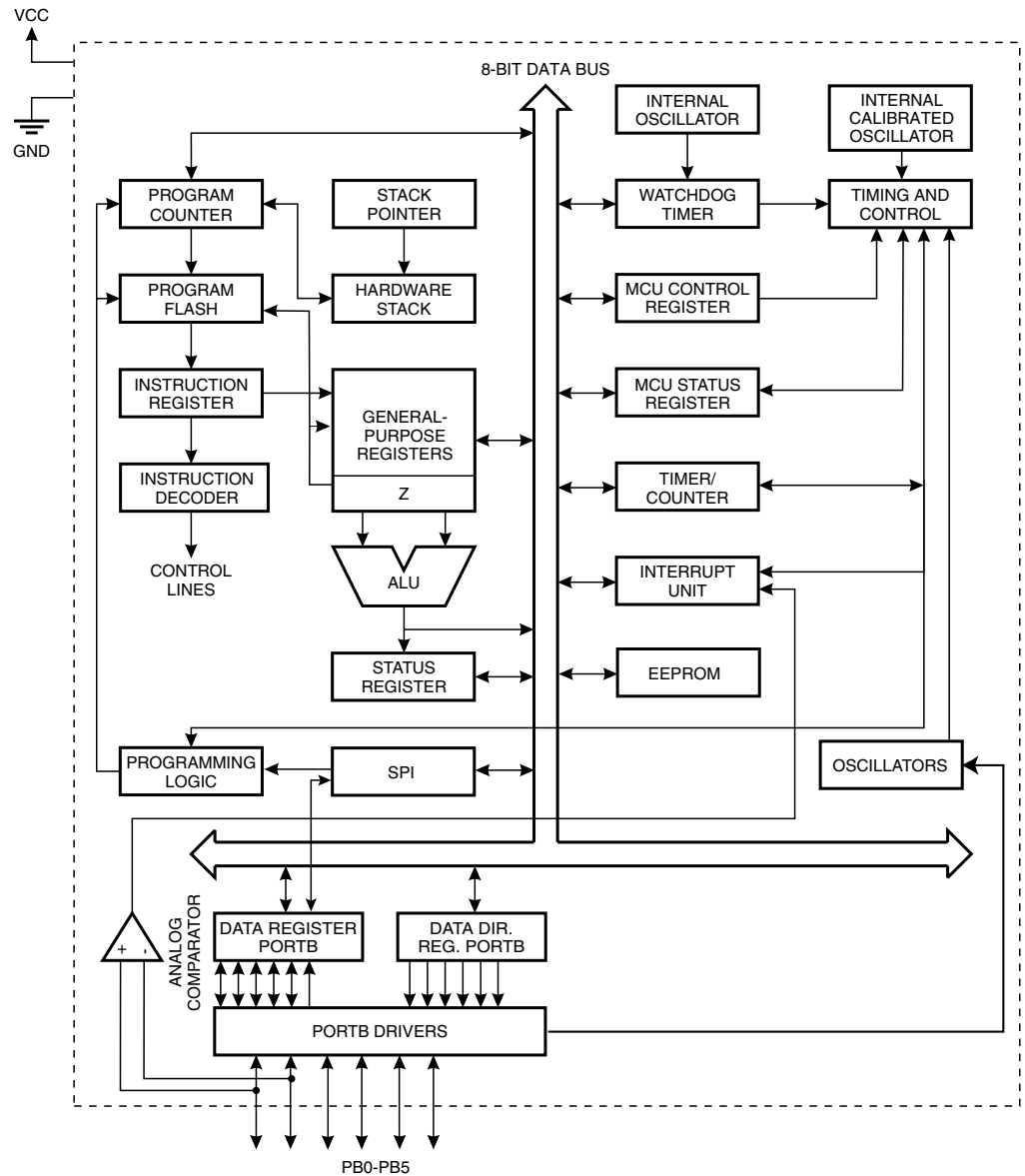

The ATtiny12 provides the following features: 1K bytes of Flash, 64 bytes EEPROM, up to six general-purpose I/O lines, 32 general-purpose working registers, an 8-bit timer/counter, internal and external interrupts, programmable Watchdog Timer with internal oscillator, and two software-selectable power-saving modes. The Idle Mode stops the CPU while allowing the timer/counters and interrupt system to continue functioning. The Power-down Mode saves the register contents but freezes the oscillator, disabling all other chip functions until the next interrupt or hardware reset. The wake-up or interrupt on pin change features enable the ATtiny12 to be highly responsive to external events, still featuring the lowest power consumption while in the power-down modes.

The device is manufactured using Atmel's high-density nonvolatile memory technology. By combining an RISC 8-bit CPU with Flash on a monolithic chip, the Atmel ATtiny12 is a powerful microcontroller that provides a highly-flexible and cost-effective solution to many embedded control applications.

The ATtiny12 AVR is supported with a full suite of program and system development tools including: macro assemblers, program debugger/simulators, in-circuit emulators, and evaluation kits.

Pin Descriptions

VCC Supply voltage pin.

GND Ground pin.

Port B (PB5..PB0) Port B is a 6-bit I/O port. PB4..0 are I/O pins that can provide internal pull-ups (selected for each bit). On ATtiny11, PB5 is input only. On ATtiny12, PB5 is input or open-drain output. The port pins are tri-stated when a reset condition becomes active, even if the clock is not running. The use of pins PB5..3 as input or I/O pins is limited, depending on reset and clock settings, as shown below.

Table 2. PB5..PB3 Functionality vs. Device Clocking Options

Device Clocking Option	PB5	PB4	PB3
External Reset Enabled	Used ⁽¹⁾	-(²⁾	-
External Reset Disabled	Input ⁽³⁾ /I/O ⁽⁴⁾	-	-
External Crystal	-	Used	Used
External Low-frequency Crystal	-	Used	Used
External Ceramic Resonator	-	Used	Used
External RC Oscillator	-	I/O ⁽⁵⁾	Used
External Clock	-	I/O	Used
Internal RC Oscillator	-	I/O	I/O

- Notes:
1. "Used" means the pin is used for reset or clock purposes.
 2. "-" means the pin function is unaffected by the option.
 3. Input means the pin is a port input pin.
 4. On ATtiny11, PB5 is input only. On ATtiny12, PB5 is input or open-drain output.
 5. I/O means the pin is a port input/output pin.

XTAL1 Input to the inverting oscillator amplifier and input to the internal clock operating circuit.

XTAL2 Output from the inverting oscillator amplifier.

RESET Reset input. An external reset is generated by a low level on the $\overline{\text{RESET}}$ pin. Reset pulses longer than 50 ns will generate a reset, even if the clock is not running. Shorter pulses are not guaranteed to generate a reset.

Clock Options

The device has the following clock source options, selectable by Flash fuse bits as shown:

Table 3. Device Clocking Options Select

Device Clocking Option	ATtiny11 CKSEL2..0	ATtiny12 CKSEL3..0
External Crystal/Ceramic Resonator	111	1111 - 1010
External Low-frequency Crystal	110	1001 - 1000
External RC Oscillator	101	0111 - 0101

Table 3. Device Clocking Options Select (Continued)

Device Clocking Option	ATtiny11 CKSEL2..0	ATtiny12 CKSEL3..0
Internal RC Oscillator	100	0100 - 0010
External Clock	000	0001 - 0000
Reserved	Other Options	-

Note: "1" means unprogrammed, "0" means programmed.

The various choices for each clocking option give different start-up times as shown in Table 7 on page 18 and Table 9 on page 20.

Internal RC Oscillator

The internal RC oscillator option is an on-chip oscillator running at a fixed frequency of 1 MHz in ATtiny11 and 1.2 MHz in ATtiny12. If selected, the device can operate with no external components. The device is shipped with this option selected. On ATtiny11, the Watchdog Oscillator is used as a clock, while ATtiny12 uses a separate calibrated oscillator.

Crystal Oscillator

XTAL1 and XTAL2 are input and output, respectively, of an inverting amplifier which can be configured for use as an on-chip oscillator, as shown in Figure 3. Either a quartz crystal or a ceramic resonator may be used. Maximum frequency for crystal and resonators is 4 MHz. Minimum voltage for running on a low-frequency crystal is 2.5V.

Figure 3. Oscillator Connections

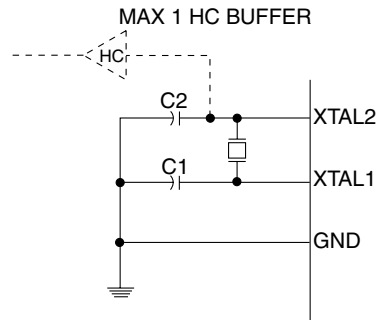

Note: When using the MCU Oscillator as a clock for an external device, an HC buffer should be connected as indicated in the figure.

External Clock

To drive the device from an external clock source, XTAL1 should be driven as shown in Figure 4.

Figure 4. External Clock Drive Configuration

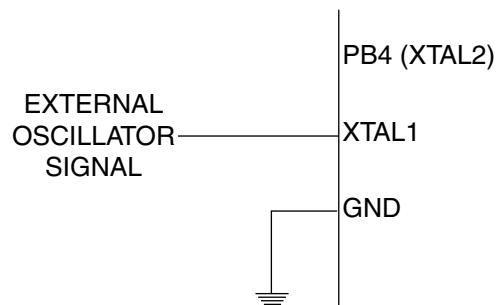

External RC Oscillator

For timing insensitive applications, the external RC configuration shown in Figure 5 can be used. For details on how to choose R and C, see Table 29 on page 57. The external RC oscillator is sensitive to noise from neighboring pins, and to avoid problems, PB5 ($\overline{\text{RESET}}$) should be used as an output or reset pin, and PB4 should be used as an output pin.

Figure 5. External RC Configuration

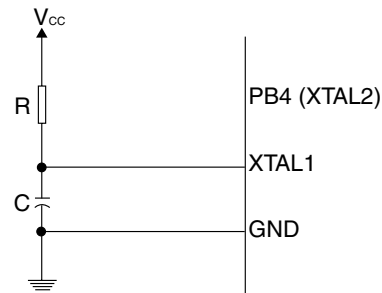

Architectural Overview

The fast-access register file concept contains 32 x 8-bit general-purpose working registers with a single-clock-cycle access time. This means that during one single clock cycle, one ALU (Arithmetic Logic Unit) operation is executed. Two operands are output from the register file, the operation is executed, and the result is stored back in the register file – in one clock cycle.

Two of the 32 registers can be used as a 16-bit pointer for indirect memory access. This pointer is called the Z-pointer, and can address the register file and the Flash program memory.

The ALU supports arithmetic and logic functions between registers or between a constant and a register. Single-register operations are also executed in the ALU. Figure 2 shows the ATtiny11/12 AVR RISC microcontroller architecture. The AVR uses a Harvard architecture concept with separate memories and buses for program and data memories. The program memory is accessed with a two-stage pipelining. While one instruction is being executed, the next instruction is pre-fetched from the program memory. This concept enables instructions to be executed in every clock cycle. The program memory is reprogrammable Flash memory.

With the relative jump and relative call instructions, the whole 512 address space is directly accessed. All AVR instructions have a single 16-bit word format, meaning that every program memory address contains a single 16-bit instruction.

During interrupts and subroutine calls, the return address program counter (PC) is stored on the stack. The stack is a 3-level-deep hardware stack dedicated for subroutines and interrupts.

The I/O memory space contains 64 addresses for CPU peripheral functions as control registers, timer/counters, and other I/O functions. The memory spaces in the AVR architecture are all linear and regular memory maps.

Figure 6. The ATtiny11/12 AVR RISC Architecture

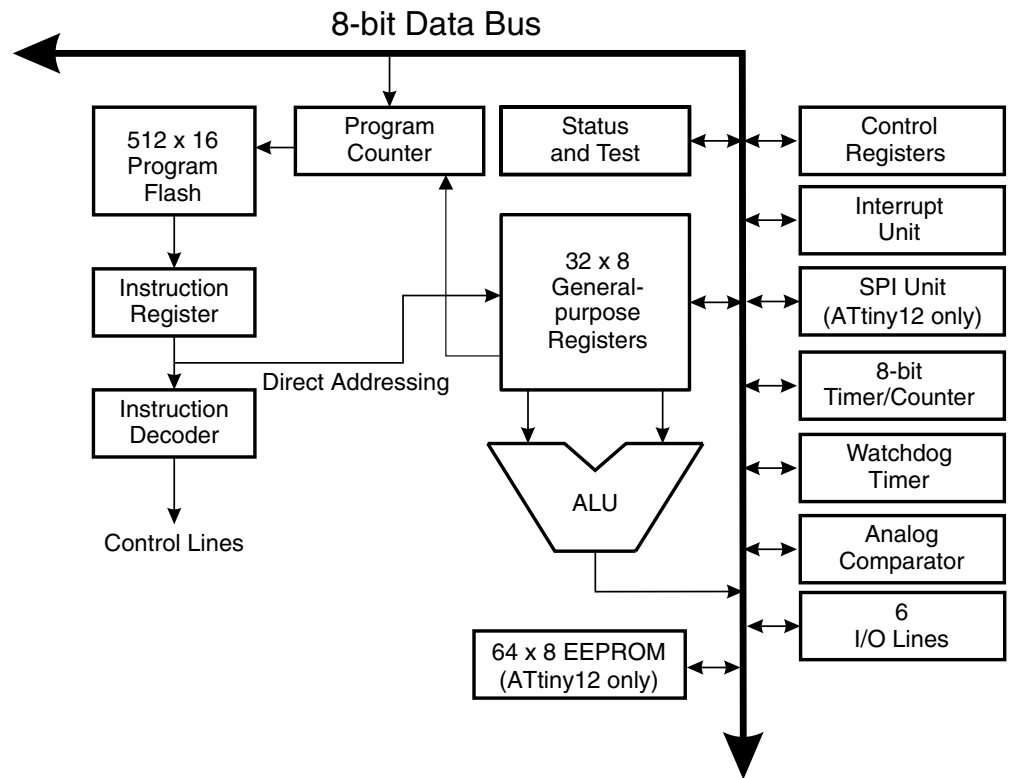

A flexible interrupt module has its control registers in the I/O space with an additional global interrupt enable bit in the status register. All the different interrupts have a separate interrupt vector in the interrupt vector table at the beginning of the program memory. The different interrupts have priority in accordance with their interrupt vector position. The lower the interrupt vector address, the higher the priority.

General-purpose Register File

Figure 7 shows the structure of the 32 general-purpose registers in the CPU.

Figure 7. AVR CPU General-purpose Working Registers

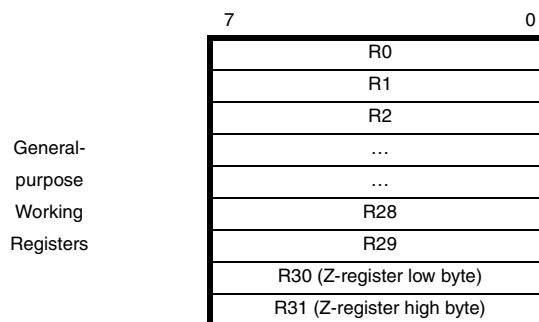

All the register operating instructions in the instruction set have direct- and single-cycle access to all registers. The only exception is the five constant arithmetic and logic instructions SBCI, SUBI, CPI, ANDI, and ORI between a constant and a register and the LDI instruction for load-immediate constant data. These instructions apply to the second half of the registers in the register file – R16..R31. The general SBC, SUB, CP, AND,

OR and all other operations between two registers or on a single register apply to the entire register file.

Registers 30 and 31 form a 16-bit pointer (the Z-pointer) which is used for indirect Flash memory and register file access. When the register file is accessed, the contents of R31 are discarded by the CPU.

ALU – Arithmetic Logic Unit

The high-performance AVR ALU operates in direct connection with all the 32 general-purpose working registers. Within a single clock cycle, ALU operations between registers in the register file are executed. The ALU operations are divided into three main categories – arithmetic, logic and bit-functions. Some microcontrollers in the AVR product family feature a hardware multiplier in the arithmetic part of the ALU.

Flash Program Memory

The ATtiny11/12 contains 1K bytes on-chip Flash memory for program storage. Since all instructions are single 16-bit words, the Flash is organized as 512 x 16 words. The Flash memory has an endurance of at least 1000 write/erase cycles.

The ATtiny11/12 Program Counter is 9 bits wide, thus addressing the 512 words Flash program memory.

See page 44 for a detailed description on Flash memory programming.

Program and Data Addressing Modes

The ATtiny11/12 AVR RISC Microcontroller supports powerful and efficient addressing modes. This section describes the different addressing modes supported in the ATtiny11/12. In the figures, OP means the operation code part of the instruction word. To simplify, not all figures show the exact location of the addressing bits.

Register Direct, Single Register Rd

Figure 8. Direct Single-register Addressing

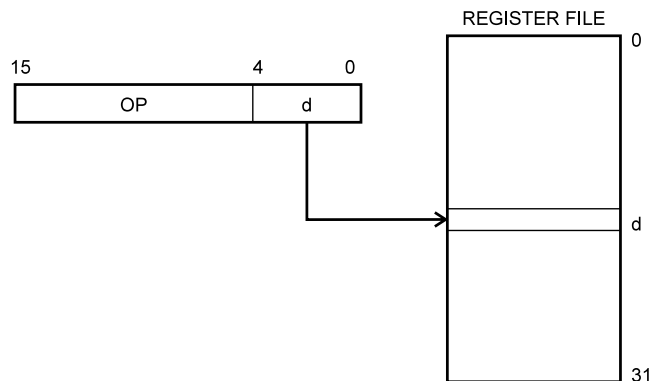

The operand is contained in register d (Rd).

Register Indirect

Figure 9. Indirect Register Addressing

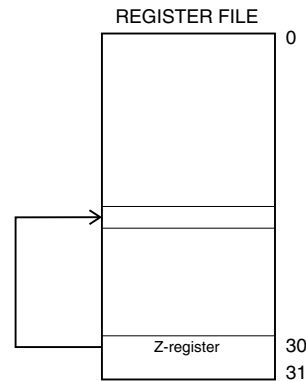

The register accessed is the one pointed to by the Z-register (R31, R30).

Register Direct, Two Registers Rd and Rr

Figure 10. Direct Register Addressing, Two Registers

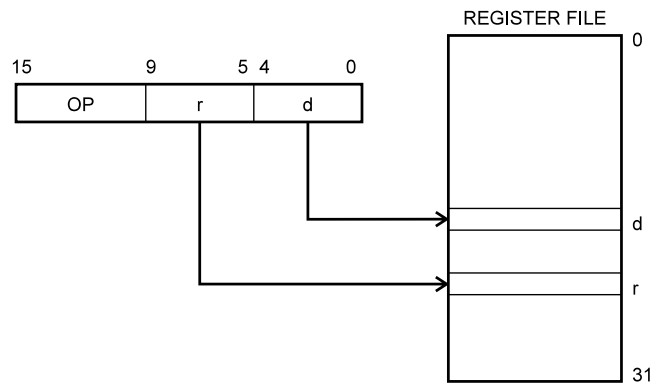

Operands are contained in register r (Rr) and d (Rd). The result is stored in register d (Rd).

I/O Direct

Figure 11. I/O Direct Addressing

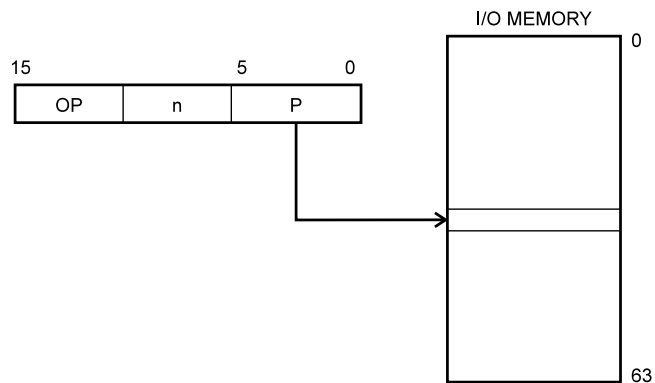

Operand address is contained in 6 bits of the instruction word. n is the destination or source register address.

Relative Program Addressing, Rjmp and Rcall

Figure 12. Relative Program Memory Addressing

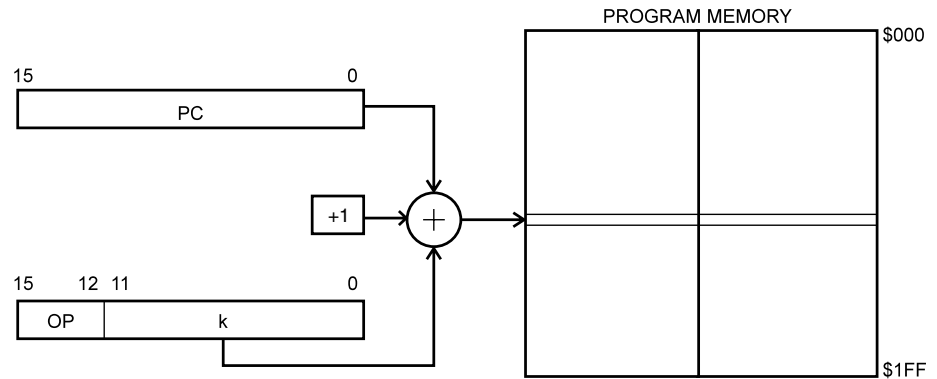

Program execution continues at address $PC + k + 1$. The relative address k is -2048 to 2047 .

Constant Addressing Using the LPM Instruction

Figure 13. Code Memory Constant Addressing

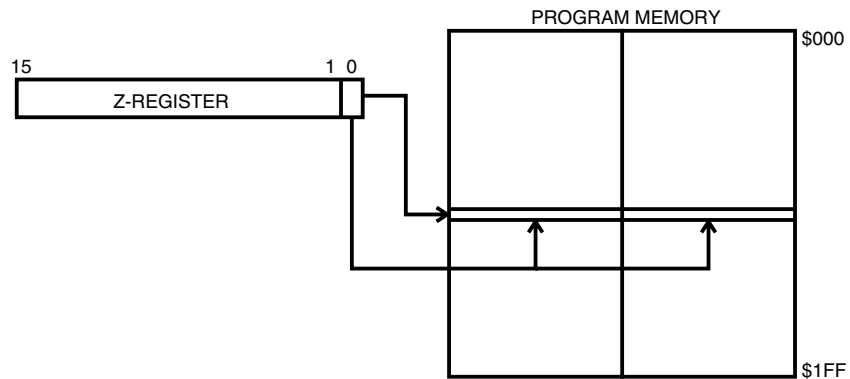

Constant byte address is specified by the Z-register contents. The 15 MSBs select word address (0 - 511), the LSB selects low byte if cleared (LSB = 0) or high byte if set (LSB = 1).

Subroutine and Interrupt Hardware Stack

The ATtiny11/12 uses a 3-level-deep hardware stack for subroutines and interrupts. The hardware stack is 9 bits wide and stores the program counter (PC) return address while subroutines and interrupts are executed.

RCALL instructions and interrupts push the PC return address onto stack level 0, and the data in the other stack levels 1-2 are pushed one level deeper in the stack. When a RET or RETI instruction is executed the returning PC is fetched from stack level 0, and the data in the other stack levels 1-2 are popped one level in the stack.

If more than three subsequent subroutine calls or interrupts are executed, the first values written to the stack are overwritten. Pushing four return addresses A1, A2, A3, and A4, followed by four subroutine or interrupt returns, will pop A4, A3, A2, and once more A2 from the hardware stack.

EEPROM Data Memory

The ATtiny12 contains 64 bytes of data EEPROM memory. It is organized as a separate data space, in which single bytes can be read and written. The EEPROM has an endurance of at least 100,000 write/erase cycles. The access between the EEPROM and the CPU is described on page 36, specifying the EEPROM Address Register, the EEPROM Data Register, and the EEPROM Control Register.

For SPI data downloading, see “Memory Programming” on page 44 for a detailed description.

Memory Access and Instruction Execution Timing

This section describes the general access timing concepts for instruction execution and internal memory access.

The AVR CPU is driven by the System Clock \emptyset , directly generated from the external clock crystal for the chip. No internal clock division is used.

Figure 14 shows the parallel instruction fetches and instruction executions enabled by the Harvard architecture and the fast-access register file concept. This is the basic pipelining concept to obtain up to 1 MIPS per MHz with the corresponding unique results for functions per cost, functions per clocks, and functions per power-unit.

Figure 14. The Parallel Instruction Fetches and Instruction Executions

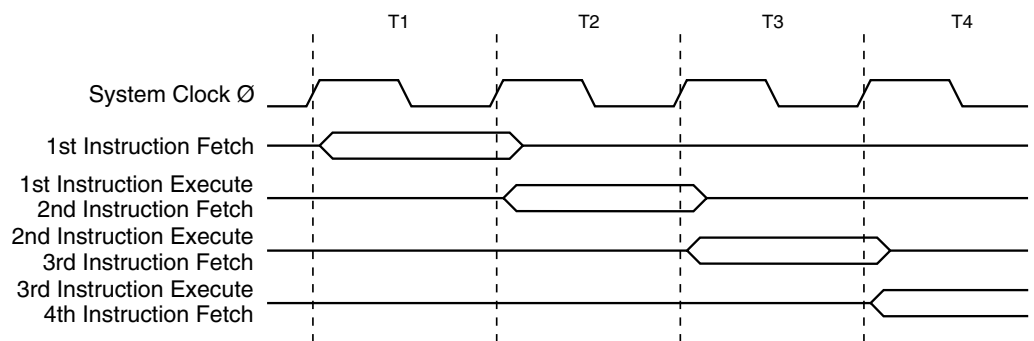
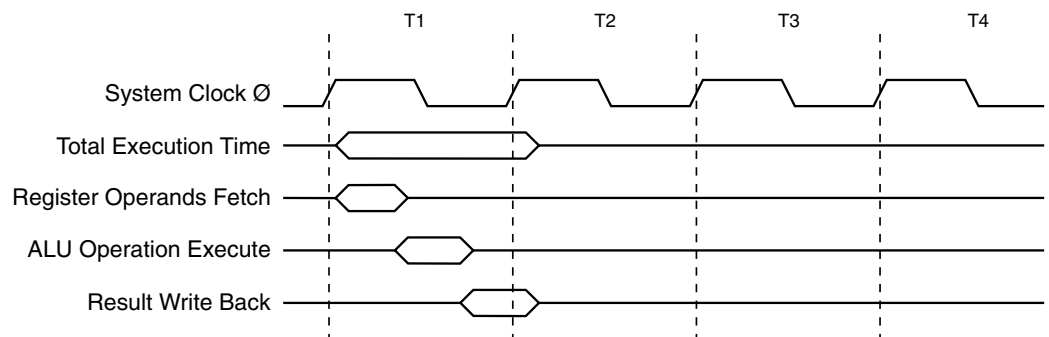

Figure 15 shows the internal timing concept for the register file. In a single clock cycle, an ALU operation using two register operands is executed and the result is stored back to the destination register.

Figure 15. Single-cycle ALU Operation





I/O Memory

The I/O space definition of the ATtiny11/12 is shown in the following table:

Table 4. ATtiny11/12 I/O Space

Address Hex	Name	Device	Function
\$3F	SREG	ATtiny11/12	Status Register
\$3B	GIMSK	ATtiny11/12	General Interrupt Mask Register
\$3A	GIFR	ATtiny11/12	General Interrupt Flag Register
\$39	TIMSK	ATtiny11/12	Timer/Counter Interrupt Mask Register
\$38	TIFR	ATtiny11/12	Timer/Counter Interrupt Flag Register
\$35	MCUCR	ATtiny11/12	MCU Control Register
\$34	MCUSR	ATtiny11/12	MCU Status Register
\$33	TCCR0	ATtiny11/12	Timer/Counter0 Control Register
\$32	TCNT0	ATtiny11/12	Timer/Counter0 (8-bit)
\$31	OSCCAL	ATtiny12	Oscillator Calibration Register
\$21	WDTCR	ATtiny11/12	Watchdog Timer Control Register
\$1E	EEAR	ATtiny12	EEPROM Address Register
\$1D	EEDR	ATtiny12	EEPROM Data Register
\$1C	EECR	ATtiny12	EEPROM Control Register
\$18	PORTB	ATtiny11/12	Data Register, Port B
\$17	DDRB	ATtiny11/12	Data Direction Register, Port B
\$16	PINB	ATtiny11/12	Input Pins, Port B
\$08	ACSR	ATtiny11/12	Analog Comparator Control and Status Register

Note: Reserved and unused locations are not shown in the table.

All the different ATtiny11/12 I/O and peripherals are placed in the I/O space. The different I/O locations are accessed by the IN and OUT instructions transferring data between the 32 general-purpose working registers and the I/O space. I/O registers within the address range \$00 - \$1F are directly bit-accessible using the SBI and CBI instructions. In these registers, the value of single bits can be checked by using the SBIS and SBIC instructions. Refer to the Instruction Set Summary for more details.

For compatibility with future devices, reserved bits should be written to zero if accessed. Reserved I/O memory addressed should never be written.

The different I/O and peripherals control registers are explained in the following sections.

Status Register – SREG

The AVR status register (SREG) at I/O space location \$3F is defined as:

Bit	7	6	5	4	3	2	1	0									
\$3F	<table border="1" style="display: inline-table; border-collapse: collapse;"> <tr> <td style="width: 20px; text-align: center;">I</td> <td style="width: 20px; text-align: center;">T</td> <td style="width: 20px; text-align: center;">H</td> <td style="width: 20px; text-align: center;">S</td> <td style="width: 20px; text-align: center;">V</td> <td style="width: 20px; text-align: center;">N</td> <td style="width: 20px; text-align: center;">Z</td> <td style="width: 20px; text-align: center;">C</td> </tr> </table>								I	T	H	S	V	N	Z	C	SREG
I	T	H	S	V	N	Z	C										
Read/Write	R/W	R/W	R/W	R/W	R/W	R/W	R/W	R/W	R/W								
Initial Value	0	0	0	0	0	0	0	0									

- **Bit 7 - I: Global Interrupt Enable**

The global interrupt enable bit must be set (one) for the interrupts to be enabled. The individual interrupt enable control is then performed in separate control registers. If the global interrupt enable register is cleared (zero), none of the interrupts are enabled inde-

pendent of the individual interrupt enable settings. The I-bit is cleared by hardware after an interrupt has occurred, and is set by the RETI instruction to enable subsequent interrupts.

- **Bit 6 - T: Bit Copy Storage**

The bit copy instructions BLD (Bit Load) and BST (Bit Store) use the T-bit as source and destination for the operated bit. A bit from a register in the register file can be copied into T by the BST instruction, and a bit in T can be copied into a bit in a register in the register file by the BLD instruction.

- **Bit 5 - H: Half Carry Flag**

The half carry flag H indicates a half-carry in some arithmetic operations. See the Instruction Set description for detailed information.

- **Bit 4 - S: Sign Bit, $S = N \oplus V$**

The S-bit is always an exclusive or between the negative flag N and the two's complement overflow flag V. See the Instruction Set description for detailed information.

- **Bit 3 - V: Two's Complement Overflow Flag**

The two's complement overflow flag V supports two's complement arithmetic. See the Instruction Set description for detailed information.

- **Bit 2 - N: Negative Flag**

The negative flag N indicates a negative result from an arithmetical or logical operation. See the Instruction Set description for detailed information.

- **Bit 1 - Z: Zero Flag**

The zero flag Z indicates a zero result from an arithmetical or logical operation. See the Instruction Set description for detailed information.

- **Bit 0 - C: Carry Flag**

The carry flag C indicates a carry in an arithmetical or logical operation. See the Instruction Set description for detailed information.

Note that the status register is not automatically stored when entering an interrupt routine and restored when returning from an interrupt routine. This must be handled by software.

Reset and Interrupt Handling

The ATtiny11 provides four different interrupt sources and the ATtiny12 provides five. These interrupts and the separate reset vector each have a separate program vector in the program memory space. All the interrupts are assigned individual enable bits which must be set (one) together with the I-bit in the status register in order to enable the interrupt.

The lowest addresses in the program memory space are automatically defined as the Reset and Interrupt vectors. The complete list of vectors is shown in Table 5. The list also determines the priority levels of the different interrupts. The lower the address, the higher the priority level. RESET has the highest priority, and next is INTO – the External Interrupt Request 0, etc.

Table 5. Reset and Interrupt Vectors

Vector No.	Device	Program Address	Source	Interrupt Definition
1	ATtiny11	\$000	RESET	External Pin, Power-on Reset and Watchdog Reset
1	ATtiny12	\$000	RESET	External Pin, Power-on Reset, Brown-out Reset and Watchdog Reset
2	ATtiny11/12	\$001	INT0	External Interrupt Request 0
3	ATtiny11/12	\$002	I/O Pins	Pin Change Interrupt
4	ATtiny11/12	\$003	TIMER0, OVFO	Timer/Counter0 Overflow
5	ATtiny11	\$004	ANA_COMP	Analog Comparator
5	ATtiny12	\$004	EE_RDY	EEPROM Ready
6	ATtiny12	\$005	ANA_COMP	Analog Comparator

The most typical and general program setup for the reset and interrupt vector addresses for the ATtiny11 are:

```

Address  Labels  Code           Comments
$000           rjmp    RESET      ; Reset handler
$001           rjmp    EXT_INT0   ; IRQ0 handler
$002           rjmp    PIN_CHANGE ; Pin change handler
$003           rjmp    TIM0_OVF   ; Timer0 overflow handler
$004           rjmp    ANA_COMP   ; Analog Comparator handler
;
$005  MAIN:    <instr> xxx      ; Main program start
...           ...           ...

```

The most typical and general program setup for the reset and interrupt vector addresses for the ATtiny12 are:

```

Address  Labels  Code           Comments
$000           rjmp    RESET      ; Reset handler
$001           rjmp    EXT_INT0   ; IRQ0 handler
$002           rjmp    PIN_CHANGE ; Pin change handler
$003           rjmp    TIM0_OVF   ; Timer0 overflow handler
$004           rjmp    EE_RDY     ; EEPROM Ready handler
$005           rjmp    ANA_COMP   ; Analog Comparator handler
;
$006  MAIN:    <instr> xxx      ; Main program start
...           ...           ...

```

Reset Sources

The ATtiny11/12 provides three or four sources of reset:

- Power-on Reset. The MCU is reset when the supply voltage is below the power-on reset threshold (V_{POT}).
- External Reset. The MCU is reset when a low level is present on the \overline{RESET} pin for more than 50 ns.
- Watchdog Reset. The MCU is reset when the Watchdog timer period expires and the Watchdog is enabled.
- Brown-out Reset. The MCU is reset when the supply voltage V_{CC} falls below a certain voltage (ATtiny12 only).

During reset, all I/O registers are then set to their initial values, and the program starts execution from address \$000. The instruction placed in address \$000 must be an RJMP – relative jump – instruction to the reset handling routine. If the program never enables an interrupt source, the interrupt vectors are not used, and regular program code can be placed at these locations. The circuit diagram in Figure 16 shows the reset logic for the ATtiny11. Figure 17 shows the reset logic for the ATtiny12. Table 6 defines the electrical parameters of the reset circuitry for ATtiny11. Table 8 shows the parameters of the reset circuitry for ATtiny12.

Figure 16. Reset Logic for the ATtiny11

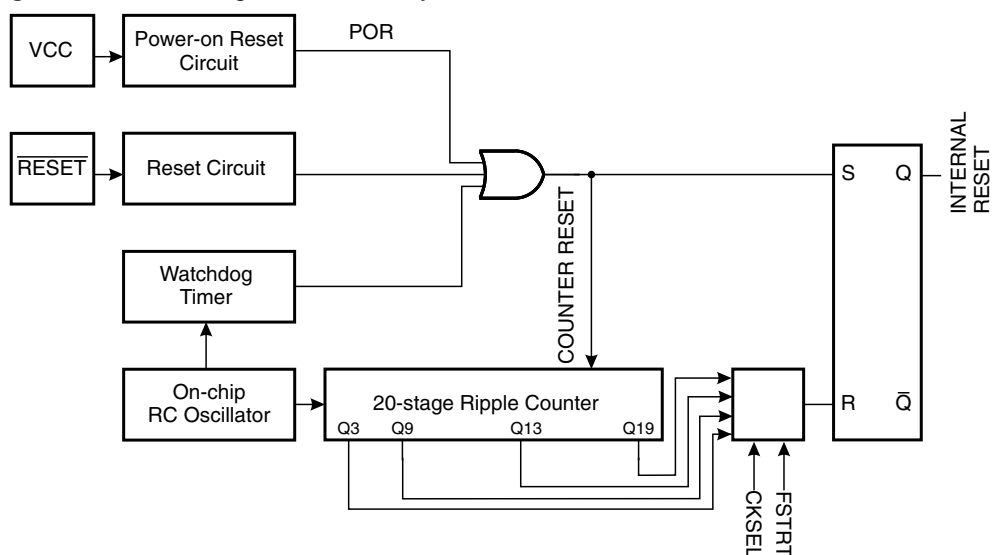

Table 6. Reset Characteristics for the ATtiny11

Symbol	Parameter	Min	Typ	Max	Units
$V_{POT}^{(1)}$	Power-on Reset Threshold Voltage (rising)	1.0	1.4	1.8	V
	Power-on Reset Threshold Voltage (falling)	0.4	0.6	0.8	V
V_{RST}	\overline{RESET} Pin Threshold Voltage		$0.6 V_{CC}$		V

Note: 1. The Power-on Reset will not work unless the supply voltage has been below V_{POT} (falling).

Power-on Reset for the ATtiny11

A Power-on Reset (POR) circuit ensures that the device is reset from power-on. As shown in Figure 16, an internal timer is clocked from the watchdog timer. This timer prevents the MCU from starting a certain period after V_{CC} has reached the Power-on Threshold Voltage – V_{POT} . See Figure 18. The total reset period is the Delay Time-out period – t_{TOUT} . The FSTRT fuse bit in the Flash can be programmed to give a shorter start-up time. The start-up times for the different clock options are shown in the following table. The Watchdog Oscillator is used for timing the start-up time, and this oscillator is voltage dependent as shown in the section “ATtiny11 Typical Characteristics” on page 58.

Table 7. Start-up Times for the ATtiny11 ($V_{CC} = 2.7V$)

Selected Clock Option	Start-up Time t_{TOUT}	
	FSTRT Unprogrammed	FSTRT Programmed
External Crystal	67 ms	4.2 ms
External Ceramic Resonator	67 ms	4.2 ms
External Low-frequency Crystal	4.2 s	4.2 s
External RC Oscillator	4.2 ms	67 μ s
Internal RC Oscillator	4.2 ms	67 μ s
External Clock	4.2 ms	5 clocks from reset, 2 clocks from power-down

If the built-in start-up delay is sufficient, \overline{RESET} can be connected to V_{CC} directly or via an external pull-up resistor. By holding the \overline{RESET} pin low for a period after V_{CC} has been applied, the Power-on Reset period can be extended. Refer to Figure 19 for a timing example on this.

Figure 17. Reset Logic for the ATtiny12

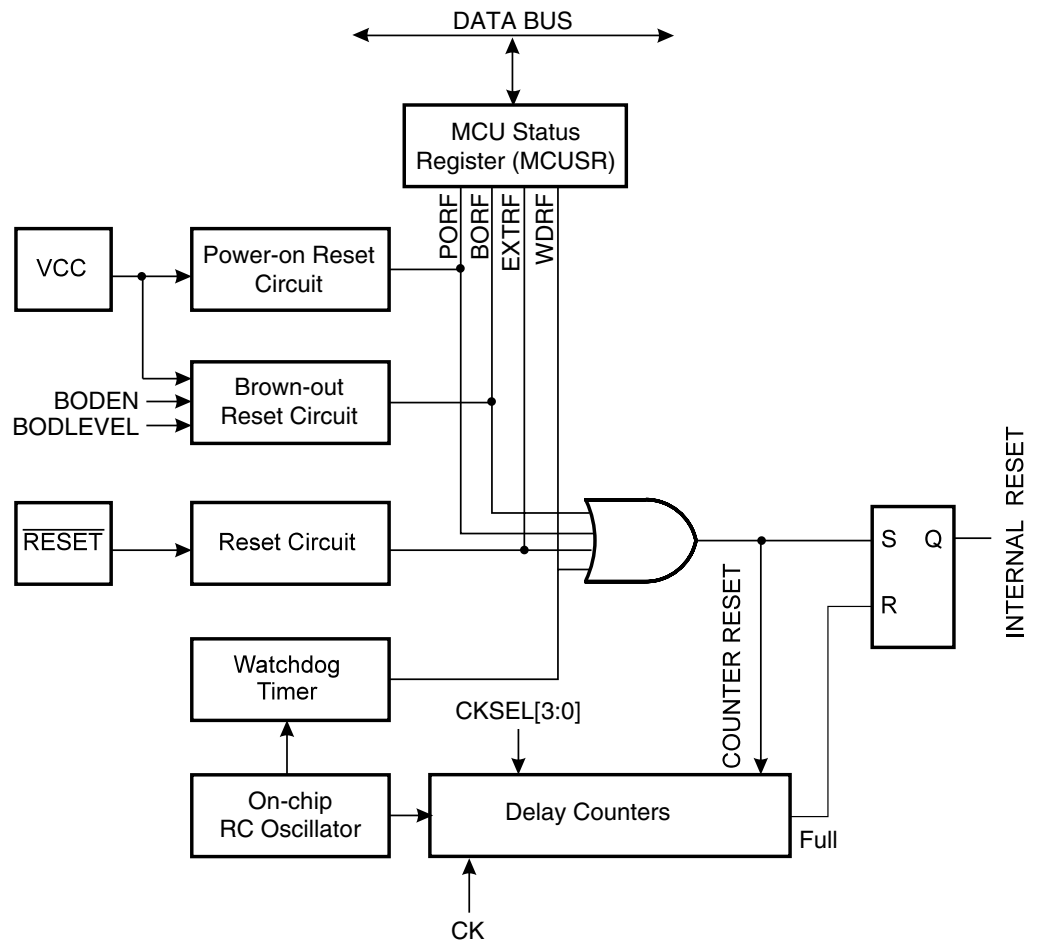

Table 8. Reset Characteristics for the ATtiny12

Symbol	Parameter	Condition	Min	Typ	Max	Units
$V_{POT}^{(1)}$	Power-on Reset Threshold Voltage (rising)	BOD disabled	1.0	1.4	1.8	V
		BOD enabled	0.6	1.2	1.8	V
	Power-on Reset Threshold Voltage (falling)	BOD disabled	0.4	0.6	0.8	V
		BOD enabled	0.6	1.2	1.8	V
V_{RST}	\overline{RESET} Pin Threshold Voltage			$0.6V_{CC}$		V
V_{BOT}	Brown-out Reset Threshold Voltage	(BODLEVEL = 1)	1.5	1.8	1.9	V
		(BODLEVEL = 0)	2.6	2.7	2.8	

Note: 1. The Power-on Reset will not work unless the supply voltage has been below V_{POT} (falling).



Table 9. ATtiny12 Clock Options and Start-up Times

CKSEL3..0	Clock Source	Start-up Time, V _{CC} = 1.8V, BODLEVEL Unprogrammed	Start-up Time, V _{CC} = 2.7V, BODLEVEL Programmed
1111	Ext. Crystal/Ceramic Resonator ⁽¹⁾	1K CK	1K CK
1110	Ext. Crystal/Ceramic Resonator ⁽¹⁾	3.6 ms + 1K CK	4.2 ms + 1K CK
1101	Ext. Crystal/Ceramic Resonator ⁽¹⁾	57 ms 1K CK	67 ms + 1K CK
1100	Ext. Crystal/Ceramic Resonator	16K CK	16K CK
1011	Ext. Crystal/Ceramic Resonator	3.6 ms + 16K CK	4.2 ms + 16K CK
1010	Ext. Crystal/Ceramic Resonator	57 ms + 16K CK	67 ms + 16K CK
1001	Ext. Low-frequency Crystal	57 ms + 1K CK	67 ms + 1K CK
1000	Ext. Low-frequency Crystal	57 ms + 32K CK	67 ms + 32K CK
0111	Ext. RC Oscillator	6 CK	6 CK
0110	Ext. RC Oscillator	3.6 ms + 6 CK	4.2 ms + 6 CK
0101	Ext. RC Oscillator	57 ms + 6 CK	67 ms + 6 CK
0100	Int. RC Oscillator	6 CK	6 CK
0011	Int. RC Oscillator	3.6 ms + 6 CK	4.2 ms + 6 CK
0010	Int. RC Oscillator	57 ms + 6 CK	67 ms + 6 CK
0001	Ext. Clock	6 CK	6 CK
0000	Ext. Clock	3.6 ms + 6 CK	4.2 ms + 6 CK

Note: 1. Due to the limited number of clock cycles in the start-up period, it is recommended that Ceramic Resonator be used.

This table shows the start-up times from reset. From sleep, only the clock counting part of the start-up time is used. The Watchdog oscillator is used for timing the real-time part of the start-up time. The number of WDT oscillator cycles used for each time-out is shown in Table 10.

Table 10. Number of Watchdog Oscillator Cycles

BODLEVEL	Time-out	Number of Cycles
Unprogrammed	3.6 ms (at V _{CC} = 1.8V)	256
Unprogrammed	57 ms (at V _{CC} = 1.8V)	4K
Programmed	4.2 ms (at V _{CC} = 2.7V)	1K
Programmed	67 ms (at V _{CC} = 2.7V)	16K

The frequency of the watchdog oscillator is voltage dependent as shown in the section “ATtiny11 Typical Characteristics” on page 58.

Note that the BODLEVEL fuse can be used to select start-up times even if the Brown-out Detection is disabled (by leaving the BODEN fuse unprogrammed).

The device is shipped with CKSEL3..0 = 0010.

Power-on Reset for the ATtiny12

A Power-on Reset (POR) pulse is generated by an on-chip detection circuit. The detection level is nominally 1.4V. The POR is activated whenever V_{CC} is below the detection level. The POR circuit can be used to trigger the start-up reset, as well as detect a failure in supply voltage.

The Power-on Reset (POR) circuit ensures that the device is reset from power-on. Reaching the Power-on Reset threshold voltage invokes a delay counter, which determines the delay for which the device is kept in Reset after V_{CC} rise. The time-out period of the delay counter can be defined by the user through the CKSEL fuses. The different selections for the delay period are presented in Table 9. The Reset signal is activated again, without any delay, when the V_{CC} decreases below detection level.

If the built-in start-up delay is sufficient, $\overline{\text{RESET}}$ can be connected to V_{CC} directly or via an external pull-up resistor. See Figure 18. By holding the $\overline{\text{RESET}}$ pin low for a period after V_{CC} has been applied, the Power-on Reset period can be extended. Refer to Figure 19 for a timing example on this.

Figure 18. MCU Start-up, $\overline{\text{RESET}}$ Tied to V_{CC} .

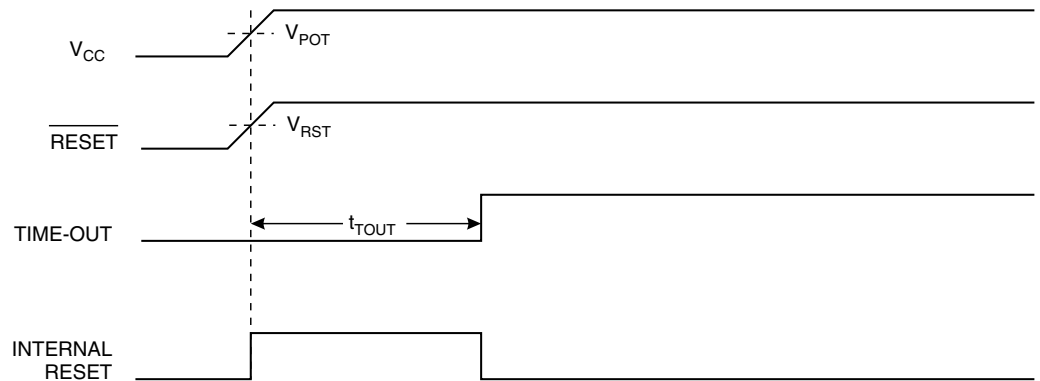
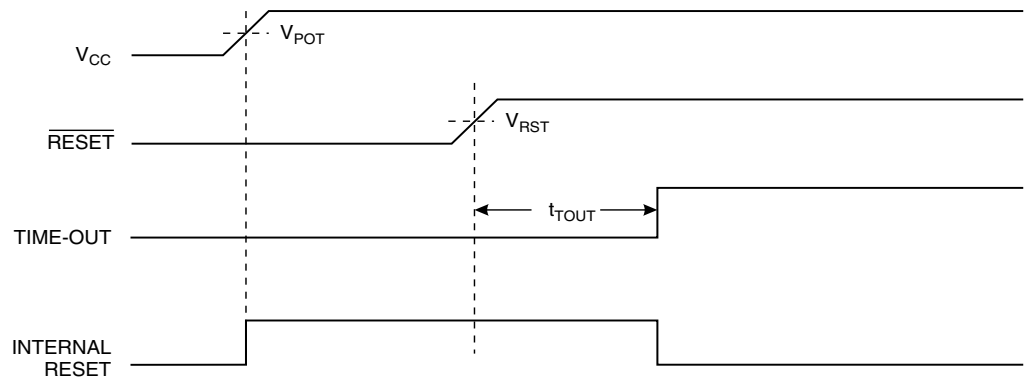

Figure 19. MCU Start-up, $\overline{\text{RESET}}$ Extended Externally



External Reset

An external reset is generated by a low level on the $\overline{\text{RESET}}$ pin. Reset pulses longer than 50 ns will generate a reset, even if the clock is not running. Shorter pulses are not guaranteed to generate a reset. When the applied signal reaches the Reset Threshold Voltage – V_{RST} – on its positive edge, the delay timer starts the MCU after the Time-out period (t_{TOUT}) has expired.

Figure 20. External Reset during Operation

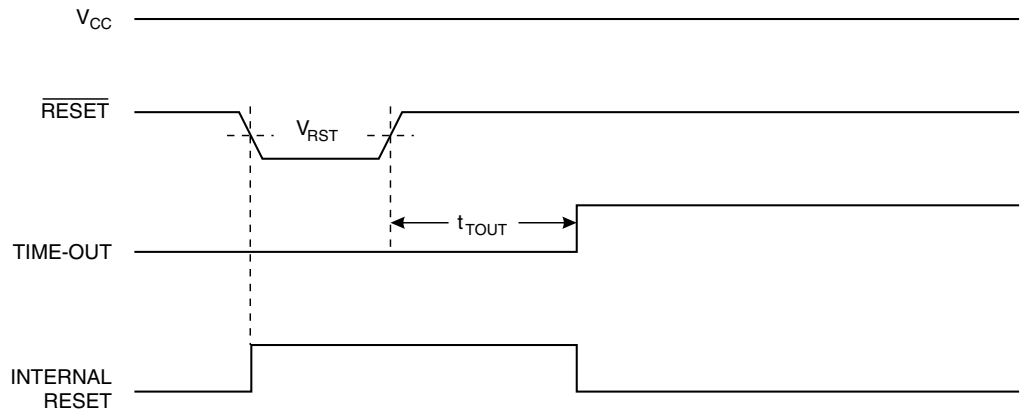

Brown-out Detection (ATtiny12)

ATtiny12 has an on-chip brown-out detection (BOD) circuit for monitoring the V_{CC} level during the operation. The BOD circuit can be enabled/disabled by the fuse BODEN. When BODEN is enabled (BODEN programmed), and V_{CC} decreases below the trigger level, the brown-out reset is immediately activated. When V_{CC} increases above the trigger level, the brown-out reset is deactivated after a delay. The delay is defined by the user in the same way as the delay of POR signal, in Table 5. The trigger level for the BOD can be selected by the fuse BODLEVEL to be 1.8V (BODLEVEL unprogrammed), or 2.7V (BODLEVEL programmed). The trigger level has a hysteresis of 50 mV to ensure spike-free brown-out detection.

The BOD circuit will only detect a drop in V_{CC} if the voltage stays below the trigger level for longer than 7 μ s for trigger level 2.7V, 24 μ s for trigger level 1.8V (typical values).

Figure 21. Brown-out Reset during Operation (ATtiny12)

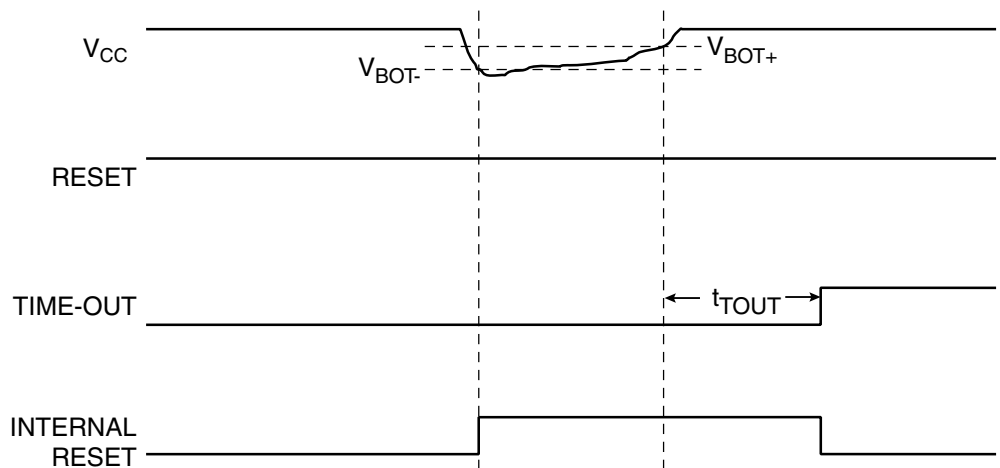

Note: The hysteresis on V_{BOT} : $V_{BOT+} = V_{BOT} + 25 \text{ mV}$, $V_{BOT-} = V_{BOT} - 25 \text{ mV}$.

Watchdog Reset

When the Watchdog times out, it will generate a short reset pulse of 1 CK cycle duration. On the falling edge of this pulse, the delay timer starts counting the Time-out period (t_{TOUT}). Refer to page 34 for details on operation of the Watchdog.

Figure 22. Watchdog Reset during Operation

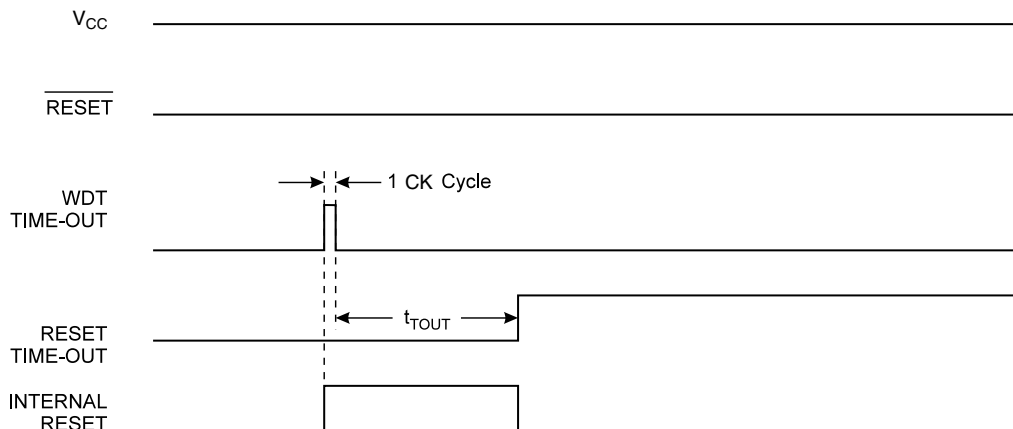

MCU Status Register – MCUSR of the ATtiny11

The MCU Status Register provides information on which reset source caused an MCU reset.

Bit	7	6	5	4	3	2	1	0	
\$34	-	-	-	-	-	-	EXTRF	PORF	MCUSR
Read/Write	R	R	R	R	R	R	R/W	R/W	
Initial Value	0	0	0	0	0	0	See bit description		

- **Bit 7..2 - Res: Reserved Bits**

These bits are reserved bits in the ATtiny11 and always read as zero.

- **Bit 1 - EXTRF: EXTERNAL Reset Flag**

After a power-on reset, this bit is undefined (X). It will be set by an external reset. A watchdog reset will leave this bit unchanged.

- **Bit 0 - PORF: Power-on Reset Flag**

This bit is set by a power-on reset. A watchdog reset or an external reset will leave this bit unchanged.

To summarize, the following table shows the value of these two bits after the three modes of reset.

Table 11. PORF and EXTRF Values after Reset

Reset Source	EXTRF	PORF
Power-on	Undefined	1
External Reset	1	Unchanged
Watchdog Reset	Unchanged	Unchanged

To identify a reset condition, the user software should clear both the PORF and EXTRF bits as early as possible in the program. Checking the PORF and EXTRF values is done before the bits are cleared. If the bit is cleared before an external or watchdog reset occurs, the source of reset can be found by using the following truth table:

Table 12. Reset Source Identification

EXTRF	PORF	Reset Source
0	0	Watchdog Reset
1	0	External Reset
0	1	Power-on Reset
1	1	Power-on Reset

**MCU Status Register –
MCUSR for the ATtiny12**

The MCU Status Register provides information on which reset source caused an MCU reset.

Bit	7	6	5	4	3	2	1	0	
\$34	-	-	-	-	WDRF	BORF	EXTRF	PORF	MCUSR
Read/Write	R	R	R	R	R/W	R/W	R/W	R/W	
Initial Value	0	0	0	0	See Bit Description				

• **Bit 7..4 - Res: Reserved Bits**

These bits are reserved bits in the ATtiny12 and always read as zero.

• **Bit 3 - WDRF: Watchdog Reset Flag**

This bit is set if a watchdog reset occurs. The bit is reset by a power-on reset, or by writing a logic zero to the flag.

• **Bit 2 - BORF: Brown-out Reset Flag**

This bit is set if a brown-out reset occurs. The bit is reset by a power-on reset, or by writing a logic zero to the flag.

• **Bit 1 - EXTRF: EXTERNAL Reset Flag**

This bit is set if an external reset occurs. The bit is reset by a power-on reset, or by writing a logic zero to the flag.

• **Bit 0 - PORF: Power-on Reset Flag**

This bit is set if a power-on reset occurs. The bit is reset by writing a logic zero to the flag.

To use the reset flags to identify a reset condition, the user should read and then reset the MCUSR as early as possible in the program. If the register is cleared before another reset occurs, the source of the reset can be found by examining the reset flags.

ATtiny12 Internal Voltage Reference

ATtiny12 features an internal voltage reference with a nominal voltage of 1.22V. This reference is used for Brown-out Detection, and it can be used as an input to the Analog Comparator.

Voltage Reference Enable Signals and Start-up Time

The voltage reference has a start-up time that may influence the way it should be used. The maximum start-up time is 10µs. To save power, the reference is not always turned on. The reference is on during the following situations:

1. When BOD is enabled (by programming the BODEN fuse)
2. When the bandgap reference is connected to the Analog Comparator (by setting the AINBG bit in ACSR)

Thus, when BOD is not enabled, after setting the AINBG bit, the user must always allow the reference to start up before the output from the Analog Comparator is used. The

bandgap reference uses approximately 10 μ A, and to reduce power consumption in Power-down mode, the user can turn off the reference when entering this mode.

Interrupt Handling

The ATtiny11/12 has two 8-bit Interrupt Mask control registers; GIMSK – General Interrupt Mask register and TIMSK – Timer/Counter Interrupt Mask register.

When an interrupt occurs, the Global Interrupt Enable I-bit is cleared (zero) and all interrupts are disabled. The user software can set (one) the I-bit to enable nested interrupts. The I-bit is set (one) when a Return from Interrupt instruction – RETI – is executed.

When the Program Counter is vectored to the actual interrupt vector in order to execute the interrupt handling routine, hardware clears the corresponding flag that generated the interrupt. Some of the interrupt flags can also be cleared by writing a logic one to the flag bit position(s) to be cleared.

If an interrupt condition occurs when the corresponding interrupt enable bit is cleared (zero), the interrupt flag will be set and remembered until the interrupt is enabled, or the flag is cleared by software.

If one or more interrupt conditions occur when the global interrupt enable bit is cleared (zero), the corresponding interrupt flag(s) will be set and remembered until the global interrupt enable bit is set (one), and will be executed by order of priority.

Note that external level interrupt does not have a flag, and will only be remembered for as long as the interrupt condition is active.

Note that the status register is not automatically stored when entering an interrupt routine and restored when returning from an interrupt routine. This must be handled by software.

Interrupt Response Time

The interrupt execution response for all the enabled AVR interrupts is 4 clock cycles minimum. After the 4 clock cycles, the program vector address for the actual interrupt handling routine is executed. During this 4-clock-cycle period, the Program Counter (9 bits) is pushed onto the Stack. The vector is normally a relative jump to the interrupt routine, and this jump takes 2 clock cycles. If an interrupt occurs during execution of a multi-cycle instruction, this instruction is completed before the interrupt is served. In ATtiny12, if an interrupt occurs when the MCU is in Sleep mode, the interrupt response time is increased by 4 clock cycles.

A return from an interrupt handling routine takes 4 clock cycles. During these 4 clock cycles, the Program Counter (9 bits) is popped back from the Stack, and the I-flag in SREG is set. When AVR exits from an interrupt, it will always return to the main program and execute one more instruction before any pending interrupt is served.

General Interrupt Mask Register – GIMSK

Bit	7	6	5	4	3	2	1	0	
\$3B	-	INT0	PCIE	-	-	-	-	-	GIMSK
Read/Write	R	R/W	R/W	R	R	R	R	R	
Initial Value	0	0	0	0	0	0	0	0	

- **Bit 7 - Res: Reserved Bit**

This bit is a reserved bit in the ATtiny11/12 and always reads as zero.

- **Bit 6 - INT0: External Interrupt Request 0 Enable**

When the INT0 bit is set (one) and the I-bit in the Status Register (SREG) is set (one), the external pin interrupt is enabled. The Interrupt Sense Control0 bits 1/0 (ISC01 and ISC00) in the MCU general Control Register (MCUCR) define whether the external

interrupt is activated on rising or falling edge, on pin change, or low level of the INT0 pin. Activity on the pin will cause an interrupt request even if INT0 is configured as an output. The corresponding interrupt of External Interrupt Request 0 is executed from program memory address \$001. See also “External Interrupts.”

- **Bit 5 - PCIE: Pin Change Interrupt Enable**

When the PCIE bit is set (one) and the I-bit in the Status Register (SREG) is set (one), the interrupt on pin change is enabled. Any change on any input or I/O pin will cause an interrupt. The corresponding interrupt of Pin Change Interrupt Request is executed from program memory address \$002. See also “Pin Change Interrupt.”

- **Bits 4..0 - Res: Reserved Bits**

These bits are reserved bits in the ATtiny11/12 and always read as zero.

General Interrupt Flag Register – GIFR

Bit	7	6	5	4	3	2	1	0	
\$3A	-	INTF0	PCIF	-	-	-	-	-	GIFR
Read/Write	R	R/W	R/W	R	R	R	R	R	
Initial Value	0	0	0	0	0	0	0	0	

- **Bit 7 - Res: Reserved Bit**

This bit is a reserved bit in the ATtiny11/12 and always reads as zero.

- **Bit 6 - INTF0: External Interrupt Flag0**

When an edge on the INT0 pin triggers an interrupt request, the corresponding interrupt flag, INTF0 becomes set (one). If the I-bit in SREG and the corresponding interrupt enable bit, INT0 bit in GIMSK, are set (one), the MCU will jump to the interrupt vector. The flag is cleared when the interrupt routine is executed. Alternatively, the flag can be cleared by writing a logical one to it. The flag is always cleared when INT0 is configured as level interrupt.

- **Bit 5 - PCIF: Pin Change Interrupt Flag**

When an event on any input or I/O pin triggers an interrupt request, PCIF becomes set (one). If the I-bit in SREG and the PCIE bit in GIMSK are set (one), the MCU will jump to the interrupt vector at address \$002. The flag is cleared when the interrupt routine is executed. Alternatively, the flag can be cleared by writing a logical one to it.

- **Bits 4..0 - Res: Reserved Bits**

These bits are reserved bits in the ATtiny11/12 and always read as zero.

Timer/Counter Interrupt Mask Register – TIMSK

Bit	7	6	5	4	3	2	1	0	
\$39	-	-	-	-	-	-	TOIE0	-	TIMSK
Read/Write	R	R	R	R	R	R	R/W	R	
Initial Value	0	0	0	0	0	0	0	0	

- **Bit 7..2 - Res: Reserved Bits**

These bits are reserved bits in the ATtiny11/12 and always read as zero.

- **Bit 1 - TOIE0: Timer/Counter0 Overflow Interrupt Enable**

When the TOIE0 bit is set (one) and the I-bit in the Status Register is set (one), the Timer/Counter0 Overflow interrupt is enabled. The corresponding interrupt (at vector \$003) is executed if an overflow in Timer/Counter0 occurs, i.e., when the Overflow Flag (Timer0) is set (one) in the Timer/Counter Interrupt Flag Register – TIFR.

- **Bit 0 - Res: Reserved Bit**

This bit is a reserved bit in the ATtiny11/12 and always reads as zero.

Timer/Counter Interrupt Flag Register – TIFR

Bit	7	6	5	4	3	2	1	0	
\$38	-	-	-	-	-	-	TOV0	-	TIFR
Read/Write	R	R	R	R	R	R	R/W	R	
Initial Value	0	0	0	0	0	0	0	0	

- **Bits 7..2 - Res: Reserved Bits**

These bits are reserved bits in the ATtiny11/12 and always read as zero.

- **Bit 1 - TOV0: Timer/Counter0 Overflow Flag**

The bit TOV0 is set (one) when an overflow occurs in Timer/Counter0. TOV0 is cleared by hardware when executing the corresponding interrupt handling vector. Alternatively, TOV0 is cleared by writing a logical one to the flag. When the SREG I-bit, TOIE0 (Timer/Counter0 Overflow Interrupt Enable), and TOV0 are set (one), the Timer/Counter0 Overflow interrupt is executed.

- **Bit 0 - Res: Reserved bit**

This bit is a reserved bit in the ATtiny11/12 and always reads as zero.

External Interrupt

The external interrupt is triggered by the INT0 pin. Observe that, if enabled, the interrupt will trigger even if the INT0 pin is configured as an output. This feature provides a way of generating a software interrupt. The external interrupt can be triggered by a falling or rising edge, a pin change, or a low level. This is set up as indicated in the specification for the MCU Control Register – MCUCR. When the external interrupt is enabled and is configured as level triggered, the interrupt will trigger as long as the pin is held low.

The external interrupt is set up as described in the specification for the MCU Control Register – MCUCR.

Pin Change Interrupt

The pin change interrupt is triggered by any change on any input or I/O pin. Change on pins PB2..0 will always cause an interrupt. Change on pins PB5..3 will cause an interrupt if the pin is configured as input or I/O, as described in the section “Pin Descriptions” on page 5. Observe that, if enabled, the interrupt will trigger even if the changing pin is configured as an output. This feature provides a way of generating a software interrupt. Also observe that the pin change interrupt will trigger even if the pin activity triggers another interrupt, for example, the external interrupt. This implies that one external event might cause several interrupts.

The values on the pins are sampled before detecting edges. If pin change interrupt is enabled, pulses that last longer than one CPU clock period will generate an interrupt. Shorter pulses are not guaranteed to generate an interrupt.



MCU Control Register – MCUCR

The MCU Control Register contains control bits for general MCU functions.

Bit	7	6	5	4	3	2	1	0	
\$35	-	(PUD)	SE	SM	-	-	ISC01	ISC00	MCUCR
Read/Write	R	R(W)	R/W	R/W	R	R	R/W	R/W	
Initial Value	0	0	0	0	0	0	0	0	

Note: The Pull-up Disable (PUD) bit is only available in ATtiny12.

- **Bit 7 - Res: Reserved Bit**

This bit is a reserved bit in the ATtiny11/12 and always reads as zero.

- **Bit 6 - Res: Reserved Bit in ATtiny11**

This bit is a reserved bit in the ATtiny11 and always reads as zero.

- **Bit 6 - PUD: Pull-up Disable in ATtiny12**

Setting this bit, disables all pull-ups on port B. If this bit is cleared, the pull-ups can be individually enabled as described in section “I/O Port B” on page 41.

- **Bit 5 - SE: Sleep Enable**

The SE bit must be set (one) to make the MCU enter the Sleep Mode when the SLEEP instruction is executed. To avoid the MCU entering the Sleep Mode unless it is the programmer’s purpose, it is recommended to set the Sleep Enable SE bit just before the execution of the SLEEP instruction.

- **Bit 4 - SM: Sleep Mode**

This bit selects between the two available sleep modes. When SM is cleared (zero), Idle Mode is selected as Sleep Mode. When SM is set (one), Power-down Mode is selected as Sleep Mode. For details, refer to the paragraph “Sleep Modes” below.

- **Bits 3, 2 - Res: Reserved Bits**

These bits are reserved bits in the ATtiny11/12 and always read as zero.

- **Bits 1, 0 - ISC01, ISC00: Interrupt Sense Control0 Bit 1 and Bit 0**

The External Interrupt 0 is activated by the external pin INT0 if the SREG I-flag and the corresponding interrupt mask are set. The following table shows how to set the ISC bits to generate an external interrupt:

Table 13. Interrupt 0 Sense Control

ISC01	ISC00	Description
0	0	The low level of INT0 generates an interrupt request.
0	1	Any change on INT0 generates an interrupt request
1	0	The falling edge of INT0 generates an interrupt request.
1	1	The rising edge of INT0 generates an interrupt request.

The value on the INT0 pin is sampled before detecting edges. If edge interrupt is selected, pulses that last longer than one CPU clock period will generate an interrupt. Shorter pulses are not guaranteed to generate an interrupt. If low-level interrupt is selected, the low level must be held until the completion of the currently executing instruction to generate an interrupt. If enabled, a level-triggered interrupt will generate an interrupt request as long as the pin is held low.

Sleep Modes for the ATtiny11

To enter the sleep modes, the SE bit in MCUCR must be set (one) and a SLEEP instruction must be executed. The SM bit in the MCUCR register selects which sleep mode (Idle or Power-down) will be activated by the SLEEP instruction. If an enabled interrupt occurs while the MCU is in a sleep mode, the MCU awakes, executes the interrupt routine, and resumes execution from the instruction following SLEEP. On wake-up from Power Down Mode on pin change, two instruction cycles are executed before the pin change interrupt flag is updated. During these cycles, the processor executes instructions, but the interrupt condition is not readable, and the interrupt routine has not started yet. The contents of the register file and I/O memory are unaltered. If a reset occurs during Sleep Mode, the MCU wakes up and executes from the Reset vector.

Idle Mode

When the SM bit is cleared (zero), the SLEEP instruction forces the MCU into the Idle Mode, stopping the CPU but allowing Timer/Counters, Watchdog and the interrupt system to continue operating. This enables the MCU to wake up from external triggered interrupts as well as internal ones like Timer Overflow interrupt and Watchdog Reset. If wake-up from the Analog Comparator interrupt is not required, the analog comparator can be powered down by setting the ACD-bit in the Analog Comparator Control and Status register – ACSR. This will reduce power consumption in Idle Mode. When the MCU wakes up from Idle mode, the CPU starts program execution immediately.

Power-down Mode

When the SM bit is set (one), the SLEEP instruction forces the MCU into the Power-down Mode. In this mode, the external oscillator is stopped, while the external interrupts and the Watchdog (if enabled) continue operating. Only an external reset, a watchdog reset (if enabled), an external level interrupt, or a pin change interrupt can wake up the MCU.

Note that if a level-triggered or pin change interrupt is used for wake-up from power-down, the changed level must be held for a time longer than the reset delay period of t_{TOU} . Otherwise, the MCU will fail to wake up.

Sleep Modes for the ATtiny12

To enter the sleep modes, the SE bit in MCUCR must be set (one) and a SLEEP instruction must be executed. The SM bit in the MCUCR register selects which sleep mode (Idle or Power-down) will be activated by the SLEEP instruction. If an enabled interrupt occurs while the MCU is in a sleep mode, the MCU awakes. The CPU is then halted for four cycles, it executes the interrupt routine, and resumes execution from the instruction following SLEEP. The contents of the register file and I/O memory are unaltered. If a reset occurs during sleep mode, the MCU wakes up and executes from the Reset vector.

Idle Mode

When the SM bit is cleared (zero), the SLEEP instruction forces the MCU into the Idle Mode stopping the CPU but allowing Timer/Counters, Watchdog and the interrupt system to continue operating. This enables the MCU to wake up from external triggered interrupts as well as internal ones like Timer Overflow interrupt and Watchdog Reset. If wake-up from the Analog Comparator interrupt is not required, the analog comparator can be powered down by setting the ACD-bit in the Analog Comparator Control and Status Register – ACSR. This will reduce power consumption in Idle Mode.

Power-down Mode

When the SM bit is set (one), the SLEEP instruction forces the MCU into the Power-down Mode. In this mode, the external oscillator is stopped, while the external interrupts and the Watchdog (if enabled) continue operating. Only an external reset, a watchdog reset (if enabled), an external level interrupt, or a pin change interrupt can wake up the MCU.

Note that if a level triggered or pin change interrupt is used for wake-up from Power-down Mode, the changed level must be held for a time to wake up the MCU. This makes the MCU less sensitive to noise. The wake-up period is equal to the clock-counting part of the reset period (See Table 9). The MCU will wake up from the power-down if the input has the required level for two watchdog oscillator cycles. If the wake-up period is shorter than two watchdog oscillator cycles, the MCU will wake up if the input has the required level for the duration of the wake-up period. If the wake-up condition disappears before the wake-up period has expired, the MCU will wake up from power-down without executing the corresponding interrupt. The period of the watchdog oscillator is 2.7 μ s (nominal) at 3.0V and 25°C. The frequency of the watchdog oscillator is voltage dependent as shown in the section “ATtiny11 Typical Characteristics” on page 58.

When waking up from Power-down Mode, there is a delay from the wake-up condition occurs until the wake-up becomes effective. This allows the clock to restart and become stable after having been stopped. The wake-up period is defined by the same CKSEL fuses that define the reset time-out period.

ATtiny12 Calibrated Internal RC Oscillator

In ATtiny12, the calibrated internal oscillator provides a fixed 1.2 MHz (nominal) clock at 5V and 25°C. This clock may be used as the system clock. See the section “Clock Options” on page 5 for information on how to select this clock as the system clock. This oscillator can be calibrated by writing the calibration byte to the OSCCAL register. When this oscillator is used as the chip clock, the Watchdog Oscillator will still be used for the Watchdog Timer and for the reset time-out. For details on how to use the pre-programmed calibration value, see the section “Calibration Byte in ATtiny12” on page 45. At 5V and 25°C, the pre-programmed calibration byte gives a frequency within $\pm 1\%$ of the nominal frequency.

Oscillator Calibration Register – OSCCAL

Bit	7	6	5	4	3	2	1	0	
\$31	CAL7 CAL6 CAL5 CAL4 CAL3 CAL2 CAL1 CAL0								OSCCAL
Read/Write	R/W	R/W	R/W	R/W	R/W	R/W	R/W	R/W	
Initial Value	0	0	0	0	0	0	0	0	

- **Bits 7..0 - CAL7..0: Oscillator Calibration Value**

Writing the calibration byte to this address will trim the internal oscillator to remove process variations from the oscillator frequency. When OSCCAL is zero, the lowest available frequency is chosen. Writing non-zero values to this register will increase the frequency of the internal oscillator. Writing \$FF to the register gives the highest available frequency. The calibrated oscillator is used to time EEPROM access. If EEPROM is written, do not calibrate to more than 10% above the nominal frequency. Otherwise, the EEPROM write may fail. Table 14 shows the range for OSCCAL. Note that the oscillator is intended for calibration to 1.2 MHz, thus tuning to other values is not guaranteed.

Table 14. Internal RC Oscillator Frequency Range

OSCCAL Value	Min Frequency	Max Frequency
\$00	0.6 MHz	1.2 MHz
\$7F	0.8 MHz	1.7 MHz
\$FF	1.2 MHz	2.5 MHz

Timer/Counter0

The ATtiny11/12 provides one general-purpose 8-bit Timer/Counter – Timer/Counter0. The Timer/Counter0 has prescaling selection from the 10-bit prescaling timer. The Timer/Counter0 can either be used as a timer with an internal clock timebase or as a counter with an external pin connection that triggers the counting.

Timer/Counter Prescaler Figure 23 shows the Timer/Counter prescaler.

Figure 23. Timer/Counter0 Prescaler

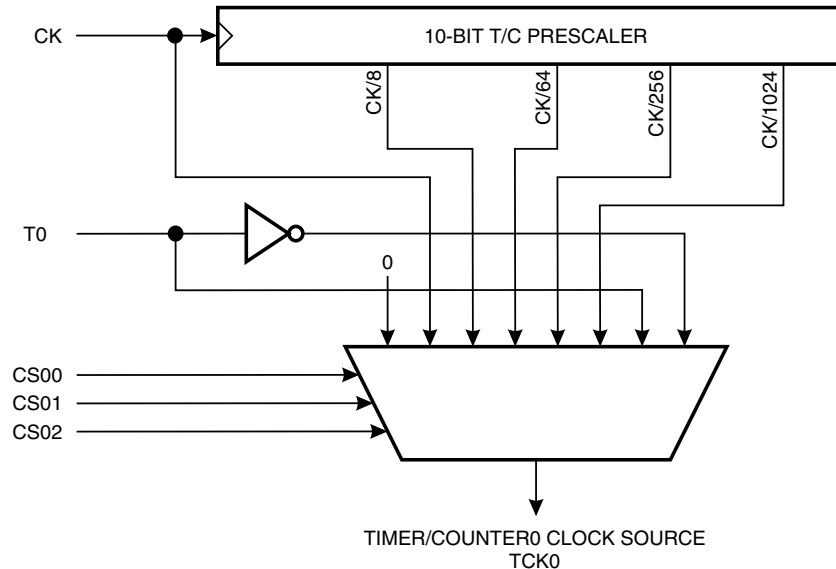

The four different prescaled selections are: CK/8, CK/64, CK/256 and CK/1024 where CK is the oscillator clock. CK, external source and stop, can also be selected as clock sources.

Figure 24 shows the block diagram for Timer/Counter0.

The 8-bit Timer/Counter0 can select clock source from CK, prescaled CK, or an external pin. In addition, it can be stopped as described in the specification for the Timer/Counter0 Control Register – TCCR0. The overflow status flag is found in the Timer/Counter Interrupt Flag Register – TIFR. Control signals are found in the Timer/Counter0 Control Register – TCCR0. The interrupt enable/disable settings for Timer/Counter0 are found in the Timer/Counter Interrupt Mask Register – TIMSK.

When Timer/Counter0 is externally clocked, the external signal is synchronized with the oscillator frequency of the CPU. To ensure proper sampling of the external clock, the minimum time between two external clock transitions must be at least one internal CPU clock period. The external clock signal is sampled on the rising edge of the internal CPU clock.

The 8-bit Timer/Counter0 features both a high-resolution and a high-accuracy usage with the lower prescaling opportunities. Similarly, the high-prescaling opportunities make the Timer/Counter0 useful for lower-speed functions or exact-timing functions with infrequent actions.

Figure 24. Timer/Counter0 Block Diagram

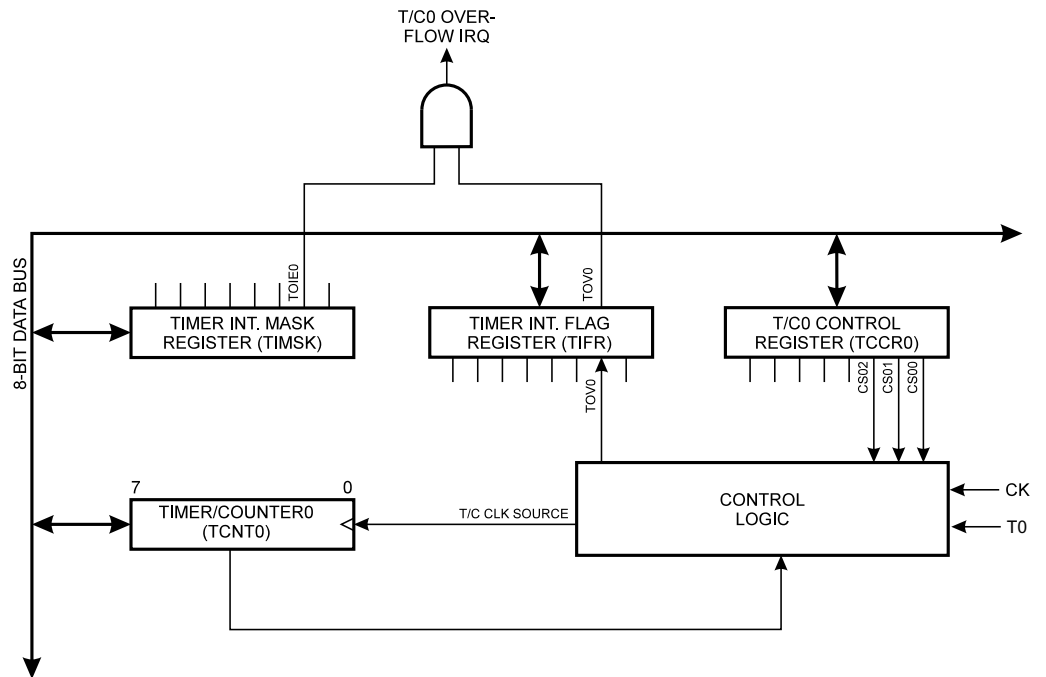

Timer/Counter0 Control Register – TCCR0

Bit	7	6	5	4	3	2	1	0	
\$33	-	-	-	-	-	CS02	CS01	CS00	TCCR0
Read/Write	R	R	R	R	R	R/W	R/W	R/W	
Initial Value	0	0	0	0	0	0	0	0	

• **Bits 7..3 - Res: Reserved Bits**

These bits are reserved bits in the ATtiny11/12 and always read as zero.

• **Bits 2,1,0 - CS02, CS01, CS00: Clock Select0, Bit 2,1 and 0**

The Clock Select0 bits 2,1 and 0 define the prescaling source of Timer0.

Table 15. Clock 0 Prescale Select

CS02	CS01	CS00	Description
0	0	0	Stop, the Timer/Counter0 is stopped.
0	0	1	CK
0	1	0	CK/8
0	1	1	CK/64
1	0	0	CK/256
1	0	1	CK/1024
1	1	0	External Pin T0, falling edge
1	1	1	External Pin T0, rising edge

The Stop condition provides a Timer Enable/Disable function. The CK down-divided modes are scaled directly from the CK oscillator clock. If the external pin modes are used for Timer/Counter0, transitions on PB2/(T0) will clock the counter even if the pin is configured as an output. This feature can give the user SW control of the counting.

Timer Counter 0 – TCNT0

Bit	7	6	5	4	3	2	1	0	
\$32	<div style="border: 1px solid black; padding: 2px; display: inline-block;"> MSB LSB </div>								TCNT0
Read/Write	R/W	R/W	R/W	R/W	R/W	R/W	R/W	R/W	R/W
Initial Value	0	0	0	0	0	0	0	0	

The Timer/Counter0 is implemented as an up-counter with read and write access. If the Timer/Counter0 is written and a clock source is present, the Timer/Counter0 continues counting in the timer clock cycle following the write operation.

Watchdog Timer

The Watchdog Timer is clocked from a separate on-chip oscillator. By controlling the Watchdog Timer prescaler, the Watchdog reset interval can be adjusted as shown in Table 16. See characterization data for typical values at other V_{CC} levels. The WDR – Watchdog Reset – instruction resets the Watchdog Timer. Eight different clock cycle periods can be selected to determine the reset period. If the reset period expires without another Watchdog reset, the ATtiny11/12 resets and executes from the reset vector. For timing details on the Watchdog reset, refer to page 23.

To prevent unintentional disabling of the watchdog, a special turn-off sequence must be followed when the watchdog is disabled. Refer to the description of the Watchdog Timer Control Register for details.

Figure 25. Watchdog Timer

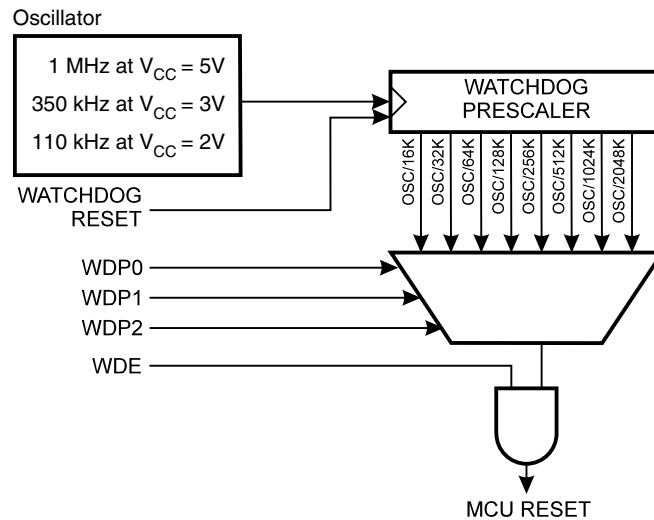

Watchdog Timer Control Register – WDTCR

Bit	7	6	5	4	3	2	1	0	
\$21	-	-	-	WDTOE	WDE	WDP2	WDP1	WDPO	WDTCR
Read/Write	R	R	R	R/W	R/W	R/W	R/W	R/W	
Initial Value	0	0	0	0	0	0	0	0	

- **Bits 7..5 - Res: Reserved Bits**

These bits are reserved bits in the ATtiny11/12 and will always read as zero.

- **Bit 4 - WDTOE: Watchdog Turn-off Enable**

This bit must be set (one) when the WDE bit is cleared. Otherwise, the watchdog will not be disabled. Once set, hardware will clear this bit to zero after four clock cycles. Refer to the description of the WDE bit for a watchdog disable procedure.

- **Bit 3 - WDE: Watchdog Enable**

When the WDE is set (one) the Watchdog Timer is enabled, and if the WDE is cleared (zero) the Watchdog Timer function is disabled. WDE can be cleared only when the WDTOE bit is set(one). To disable an enabled watchdog timer, the following procedure must be followed:

1. In the same operation, write a logical one to WDTOE and WDE. A logical one must be written to WDE even though it is set to one before the disable operation starts.
2. Within the next four clock cycles, write a logical 0 to WDE. This disables the watchdog.

• **Bits 2..0 - WDP2, WDP1, WDP0: Watchdog Timer Prescaler 2, 1 and 0**

The WDP2, WDP1 and WDP0 bits determine the Watchdog Timer prescaling when the Watchdog Timer is enabled. The different prescaling values and their corresponding time-out periods are shown in Table 16.

Table 16. Watchdog Timer Prescale Select

WDP2	WDP1	WDP0	Number of WDT Oscillator cycles	Typical Time-out at V _{CC} = 2.0V	Typical Time-out at V _{CC} = 3.0V	Typical Time-out at V _{CC} = 5.0V
0	0	0	16K cycles	0.15s	47 ms	15 ms
0	0	1	32K cycles	0.30s	94 ms	30 ms
0	1	0	64K cycles	0.60s	0.19 s	60 ms
0	1	1	128K cycles	1.2s	0.38 s	0.12 s
1	0	0	256K cycles	2.4s	0.75 s	0.24 s
1	0	1	512K cycles	4.8s	1.5 s	0.49 s
1	1	0	1,024K cycles	9.6s	3.0 s	0.97 s
1	1	1	2,048K cycles	19s	6.0 s	1.9 s

Note: The frequency of the Watchdog Oscillator is voltage dependent as shown in the section “ATtiny11 Typical Characteristics” on page 58.

The WDR – Watchdog Reset – instruction should always be executed before the Watchdog Timer is enabled. This ensures that the reset period will be in accordance with the Watchdog Timer prescale settings. If the Watchdog Timer is enabled without reset, the Watchdog Timer may not start counting from zero.

To avoid unintentional MCU resets, the Watchdog Timer should be disabled or reset before changing the Watchdog Timer Prescale Select.

ATtiny12 EEPROM Read/Write Access

The EEPROM access registers are accessible in the I/O space.

The write access time is in the range of 3.1 - 6.8 ms, depending on the frequency of the calibrated RC oscillator. See Table 17 for details. A self-timing function lets the user software detect when the next byte can be written. A special EEPROM Ready interrupt can be set to trigger when the EEPROM is ready to accept new data. The minimum voltage for writing to the EEPROM is 2.2V.

In order to prevent unintentional EEPROM writes, a two-state write procedure must be followed. Refer to the description of the EEPROM Control Register for details on this.

When the EEPROM is written, the CPU is halted for two clock cycles before the next instruction is executed. When the EEPROM is read, the CPU is halted for four clock cycles before the next instruction is executed.

EEPROM Address Register – EEAR

Bit	7	6	5	4	3	2	1	0	
\$1E	-	-	EEAR5	EEAR4	EEAR3	EEAR2	EEAR1	EEAR0	EEAR
Read/Write	R	R	R/W	R/W	R/W	R/W	R/W	R/W	
Initial Value	0	0	X	X	X	X	X	X	

The EEPROM Address Register – EEAR specifies the EEPROM address in the 64-byte EEPROM space. The EEPROM data bytes are addressed linearly between 0 and 63. During reset, the EEAR register is not cleared. Instead, the data in the register is kept.

EEPROM Data Register – EEDR

Bit	7	6	5	4	3	2	1	0	
\$1D	MSB							LSB	EEDR
Read/Write	R/W	R/W	R/W	R/W	R/W	R/W	R/W	R/W	
Initial Value	0	0	0	0	0	0	0	0	

- **Bits 7..0 - EEDR7.0: EEPROM Data**

For the EEPROM write operation, the EEDR register contains the data to be written to the EEPROM in the address given by the EEAR register. For the EEPROM read operation, the EEDR contains the data read out from the EEPROM at the address given by EEAR.

EEPROM Control Register – EECR

Bit	7	6	5	4	3	2	1	0	
\$1C	-	-	-	-	EERIE	EEMWE	EEWE	EERE	EECR
Read/Write	R	R	R	R	R/W	R/W	R/W	R/W	
Initial Value	0	0	0	0	0	0	X	0	

- **Bit 7.4 - Res: Reserved Bits**

These bits are reserved bits in the ATtiny12 and will always read as zero.

- **Bit 3 - EERIE: EEPROM Ready Interrupt Enable**

When the I-bit in SREG and EERIE are set (one), the EEPROM Ready interrupt is enabled. When cleared (zero), the interrupt is disabled. The EEPROM Ready interrupt generates a constant interrupt when EEWE is cleared (zero).

- **Bit 2 - EEMWE: EEPROM Master Write Enable**

The EEMWE bit determines whether setting EEWE to one causes the EEPROM to be written. When EEMWE is set (one), setting EEWE will write data to the EEPROM at the

selected address. If EEMWE is zero, setting EEWL will have no effect. When EEMWE has been set (one) by software, hardware clears the bit to zero after four clock cycles. See the description of the EEWL bit for a EEPROM write procedure.

• **Bit 1 - EEWL: EEPROM Write Enable**

The EEPROM Write Enable Signal EEWL is the write strobe to the EEPROM. When address and data are correctly set up, the EEWL bit must be set to write the value into the EEPROM. The EEMWE bit must be set when the logical one is written to EEWL, otherwise no EEPROM write takes place. The following procedure should be followed when writing the EEPROM (the order of steps 2 and 3 is unessential):

1. Wait until EEWL becomes zero.
2. Write new EEPROM address to EEAR (optional).
3. Write new EEPROM data to EEDR (optional).
4. Write a logical one to the EEMWE bit in EECR (to be able to write a logical one to the EEMWE bit, the EEWL bit must be written to zero in the same cycle).
5. Within four clock cycles after setting EEMWE, write a logical one to EEWL.

Caution: An interrupt between step 4 and step 5 will make the write cycle fail, since the EEPROM Master Write Enable will time-out. If an interrupt routine accessing the EEPROM is interrupting another EEPROM access, the EEAR or EEDR register will be modified, causing the interrupted EEPROM access to fail. It is recommended to have the global interrupt flag cleared during the four last steps to avoid these problems.

When the write access time has elapsed, the EEWL bit is cleared (zero) by hardware. The user software can poll this bit and wait for a zero before writing the next byte. When EEWL has been set, the CPU is halted for two cycles before the next instruction is executed.

• **Bit 0 - EERE: EEPROM Read Enable**

The EEPROM Read Enable Signal EERE is the read strobe to the EEPROM. When the correct address is set up in the EEAR register, the EERE bit must be set. When the EERE bit is cleared (zero) by hardware, requested data is found in the EEDR register. The EEPROM read access takes one instruction and there is no need to poll the EERE bit. When EERE has been set, the CPU is halted for four cycles before the next instruction is executed.

The user should poll the EEWL bit before starting the read operation. If a write operation is in progress when new data or address is written to the EEPROM I/O registers, the write operation will be interrupted, and the result is undefined.

The calibrated oscillator is used to time EEPROM. In Table 17 the typical programming time is listed for EEPROM access from the CPU.

Table 17. Typical EEPROM Programming Times

Parameter	Number of Calibrated RC Oscillator Cycles	Min Programming Time	Max Programming Time
EEPROM write (from CPU)	4096	3.1 ms	6.8 ms

Prevent EEPROM Corruption

During periods of low V_{CC} , the EEPROM data can be corrupted because the supply voltage is too low for the CPU and the EEPROM to operate properly. These issues are the same as for board-level systems using the EEPROM, and the same design solutions should be applied.

An EEPROM data corruption can be caused by two situations when the voltage is too low. First, a regular write sequence to the EEPROM requires a minimum voltage to operate correctly. Secondly, the CPU itself can execute instructions incorrectly if the supply voltage for executing instructions is too low.

EEPROM data corruption can easily be avoided by following these design recommendations (one is sufficient):

1. Keep the AVR RESET active (low) during periods of insufficient power supply voltage. This can be done by enabling the internal Brown-out Detector (BOD) if the operating speed matches the detection level. If not, an external low V_{CC} Reset Protection circuit can be applied.
2. Keep the AVR core in Power-down Sleep Mode during periods of low V_{CC} . This will prevent the CPU from attempting to decode and execute instructions, effectively protecting the EEPROM registers from unintentional writes.
3. Store constants in Flash memory if the ability to change memory contents from software is not required. Flash memory can not be updated by the CPU, and will not be subject to corruption.

Analog Comparator

The Analog Comparator compares the input values on the positive input PB0 (AIN0) and negative input PB1 (AIN1). When the voltage on the positive input PB0 (AIN0) is higher than the voltage on the negative input PB1 (AIN1), the Analog Comparator Output (ACO) is set (one). The comparator's output can trigger a separate interrupt, exclusive to the Analog Comparator. The user can select interrupt triggering on comparator output rise, fall or toggle. A block diagram of the comparator and its surrounding logic is shown in Figure 26.

Figure 26. Analog Comparator Block Diagram.

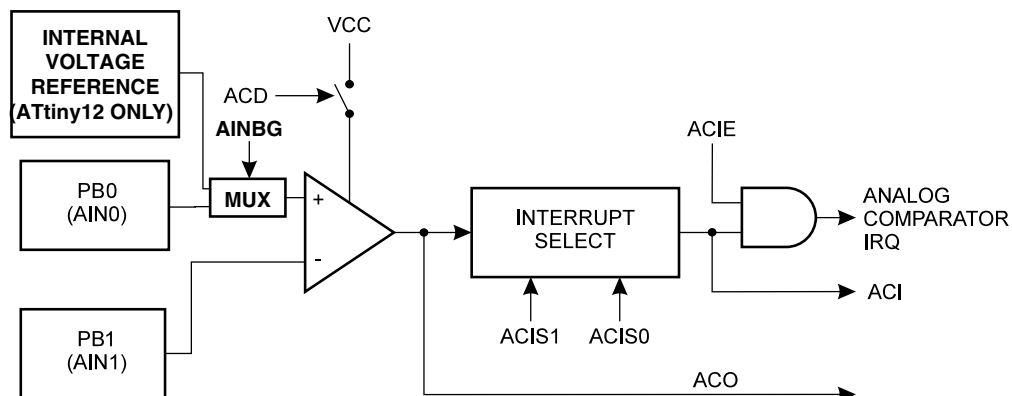

Analog Comparator Control and Status Register – ACSR

Bit	7	6	5	4	3	2	1	0	
\$08	ACD	(AINBG)	ACO	ACI	ACIE	-	ACIS1	ACIS0	ACSR
Read/Write	R/W	R/W	R	R/W	R/W	R	R/W	R/W	
Initial Value	0	0	X	0	0	0	0	0	

Note: AINBG is only available in ATtiny12.

- **Bit 7 - ACD: Analog Comparator Disable**

When this bit is set (one), the power to the Analog Comparator is switched off. This bit can be set at any time to turn off the Analog Comparator. When changing the ACD bit, the Analog Comparator Interrupt must be disabled by clearing the ACIE bit in ACSR. Otherwise an interrupt can occur when the bit is changed.

- **Bit 6 - AINBG: Analog Comparator Bandgap Select in ATtiny12**

In ATtiny12, when this bit is set, a fixed bandgap voltage of $1.22 \pm 0.05V$ replaces the normal input to the positive input (AIN0) of the comparator. When this bit is cleared, the normal input pin PB0 is applied to the positive input of the comparator.

- **Bit 6- Res: Reserved Bit in ATtiny11**

This bit is a reserved bit in the ATtiny11 and will always read as zero.

- **Bit 5 - ACO: Analog Comparator Output**

ACO is directly connected to the comparator output.

- **Bit 4 - ACI: Analog Comparator Interrupt Flag**

This bit is set (one) when a comparator output event triggers the interrupt mode defined by ACI1 and ACI0. The Analog Comparator Interrupt routine is executed if the ACIE bit is set (one) and the I-bit in SREG is set (one). ACI is cleared by hardware when executing the corresponding interrupt handling vector. Alternatively, ACI is cleared by writing a logic one to the flag.

- **Bit 3 - ACIE: Analog Comparator Interrupt Enable**

When the ACIE bit is set (one) and the I-bit in the Status Register is set (one), the Analog Comparator Interrupt is activated. When cleared (zero), the interrupt is disabled.

- **Bit 2 - Res: Reserved Bit**

This bit is a reserved bit in the ATtiny11/12 and will always read as zero.

- **Bits 1,0 - ACIS1, ACIS0: Analog Comparator Interrupt Mode Select**

These bits determine which comparator events that trigger the Analog Comparator Interrupt. The different settings are shown in Table 18.

Table 18. ACIS1/ACIS0 Settings

ACIS1	ACIS0	Interrupt Mode
0	0	Comparator Interrupt on Output Toggle
0	1	Reserved
1	0	Comparator Interrupt on Falling Output Edge
1	1	Comparator Interrupt on Rising Output Edge

Note: When changing the ACIS1/ACIS0 bits, the Analog Comparator Interrupt must be disabled by clearing its interrupt enable bit in the ACSR register. Otherwise, an interrupt can occur when the bits are changed.

Caution: Using the SBI or CBI instruction on bits other than ACI in this register will write a one back into ACI if it is read as set, thus clearing the flag.

I/O Port B

All AVR ports have true read-modify-write functionality when used as general digital I/O ports. This means that the direction of one port pin can be changed without unintentionally changing the direction of any other pin with the SBI and CBI instructions. The same applies for changing drive value (if configured as output) or enabling/disabling of pull-up resistors (if configured as input).

Port B is a 6-bit bi-directional I/O port.

Three I/O memory address locations are allocated for Port B, one each for the Data Register – PORTB, \$18, Data Direction Register – DDRB, \$17, and the Port B Input Pins – PINB, \$16. The Port B Input Pins address is read only, while the Data Register and the Data Direction Register are read/write.

Ports PB5..3 have special functions as described in the section “Pin Descriptions” on page 5. If PB5 is not configured as external reset, it is input with no pull-up. On ATtiny12, it can also output a logical zero, acting as an open-drain output. Note that, since PB5 only has one possible output value, the output functionality of this pin is controlled by the DDRB register alone. If PB4 and/or PB3 are not used for clock function, they are I/O pins. All I/O pins have individually selectable pull-ups.

The Port B output buffers on PB0 to PB4 can sink 20 mA and thus drive LED displays directly. On ATtiny12, PB5 can sink 12 mA. When pins PB0 to PB4 are used as inputs and are externally pulled low, they will source current (I_{IL}) if the internal pull-ups are activated.

The Port B pins with alternate functions are shown in Table 19:

Table 19. Port B Pins Alternate Functions

Port Pin	Alternate Functions	Device
PB0	AIN0 (Analog Comparator Positive Input)	ATtiny11/12
	MOSI (Data Input Line for Memory Downloading)	ATtiny12
PB1	INT0 (External Interrupt0 Input)	ATtiny11/12
	AIN1 (Analog Comparator Negative Input)	ATtiny11/12
	MOSI (Data Output Line for Memory Downloading)	ATtiny12
PB2	T0 (Timer/Counter0 External Counter Input)	ATtiny11/12
	SCK (Serial Clock Input for Serial Programming)	ATtiny12
PB3	XTAL1 (Oscillator Input)	ATtiny11/12
PB4	XTAL2 (Oscillator Output)	ATtiny11/12
PB5	$\overline{\text{RESET}}$ (External Reset Pin)	ATtiny11/12

When the pins PB2..0 are used for the alternate function, the DDRB and PORTB register has to be set according to the alternate function description. When PB5..3 are used for alternate functions, the values in the corresponding DDRB and PORTB bits are ignored.



Port B Data Register – PORTB

Bit	7	6	5	4	3	2	1	0	
\$18	-	-	-	PORTB4	PORTB3	PORTB2	PORTB1	PORTB0	PORTB
Read/Write	R	R	R	R/W	R/W	R/W	R/W	R/W	
Initial Value	0	0	0	0	0	0	0	0	

Port B Data Direction Register – DDRB

Bit	7	6	5	4	3	2	1	0	
\$17	-	-	(DDB5)	DDB4	DDB3	DDB2	DDB1	DDB0	DDRB
Read/Write	R	R	R(W)	R/W	R/W	R/W	R/W	R/W	
Initial Value	0	0	0	0	0	0	0	0	

Note: DDB5 is only available in ATtiny12.

Port B Input Pins Address – PINB

Bit	7	6	5	4	3	2	1	0	
\$16	-	-	PINB5	PINB4	PINB3	PINB2	PINB1	PINB0	PINB
Read/Write	R	R	R	R	R	R	R	R	
Initial Value	0	0	N/A	N/A	N/A	N/A	N/A	N/A	

The Port B Input Pins address – PINB – is not a register, and this address enables access to the physical value on each Port B pin. When reading PORTB, the Port B Data Latch is read, and when reading PINB, the logical values present on the pins are read.

Port B as General Digital I/O

The lowermost five pins in port B have equal functionality when used as digital I/O pins.

PB_n, General I/O pin: The DDB_n bit in the DDRB register selects the direction of this pin, if DDB_n is set (one), PB_n is configured as an output pin. If DDB_n is cleared (zero), PB_n is configured as an input pin. If PORTB_n is set (one) when the pin is configured as an input pin, the MOS pull-up resistor is activated. On ATtiny12 this feature can be disabled by setting the Pull-up Disable (PUD) bit in the MCUCR register. To switch the pull-up resistor off, the PORTB_n can be cleared (zero), the pin can be configured as an output pin, or in ATtiny12, the PUD bit can be set. The port pins are tri-stated when a reset condition becomes active, even if the clock is not running.

Table 20. DDB_n Effects on Port B Pins

DDB _n	PORTB _n	I/O	Pull-up	Comment
0	0	Input	No	Tri-state (Hi-Z)
0	1	Input	Yes	PB _n will source current if ext. pulled low. In ATtiny12 pull-ups can be disabled by setting the PUD bit.
1	0	Output	No	Push-pull Zero Output
1	1	Output	No	Push-pull One Output

n: 4,3...0, pin number.

Note that in ATtiny11, PB5 is input only. On ATtiny12, PB5 is input or open-drain output. Because this pin is used for 12V programming, there is no ESD protection diode limiting the voltage on the pin to $V_{CC} + 0.5V$. Thus, special care should be taken to ensure that the voltage on this pin does not rise above $V_{CC} + 1V$ during normal operation. This may cause the MCU to reset or enter programming mode unintentionally.

Alternate Functions of Port B

All port B pins are connected to a pin change detector that can trigger the pin change interrupt. See “Pin Change Interrupt” on page 27 for details. In addition, Port B has the following alternate functions:

- **RESET - Port B, Bit 5**

When the RSTDISBL fuse is unprogrammed, this pin serves as external reset. When the RSTDISBL fuse is programmed, this pin is a general input pin. In ATtiny12, it is also an open-drain output pin.

- **XTAL2 - Port B, Bit 4**

XTAL2, oscillator output. When this pin is not used for clock purposes, it is a general I/O pin. Refer to section “Pin Descriptions” on page 5 for details.

- **XTAL1 - Port B, Bit 3**

XTAL1, oscillator or clock input. When this pin is not used for clock purposes, it is a general I/O pin. Refer to section “Pin Descriptions” on page 5 for details.

- **T0/SCK - Port B, Bit 2**

This pin can serve as the external counter clock input. See the timer/counter description for further details. If external timer/counter clocking is selected, activity on this pin will clock the counter even if it is configured as an output. In ATtiny12 and serial programming mode, this pin serves as the serial clock input, SCK.

- **INT0/AIN1/MISO - Port B, Bit 1**

This pin can serve as the external interrupt0 input. See the interrupt description for details on how to enable this interrupt. Note that activity on this pin will trigger the interrupt even if the pin is configured as an output. This pin also serves as the negative input of the on-chip Analog Comparator. In ATtiny12 and serial programming mode, this pin serves as the serial data input, MISO.

- **AIN0/MOSI - Port B, Bit 0**

This pin also serves as the positive input of the on-chip Analog Comparator. In ATtiny12 and serial programming mode, this pin serves as the serial data output, MOSI.

During Power-down Mode, the schmitt triggers of the digital inputs are disconnected on the Analog Comparator input pins. This allows an analog voltage close to $V_{CC}/2$ to be present during power-down without causing excessive power consumption.

Memory Programming

Program (and Data) Memory Lock Bits

The ATtiny11/12 MCU provides two lock bits which can be left unprogrammed (“1”) or can be programmed (“0”) to obtain the additional features listed in Table 21. The lock bits can only be erased with the Chip Erase command.

Table 21. Lock Bit Protection Modes

Memory Lock Bits			Protection Type
Mode	LB1	LB2	
1	1	1	No memory lock features enabled.
2	0	1	Further programming of the Flash (and EEPROM for ATtiny12) is disabled. ⁽¹⁾
3	0	0	Same as mode 2, and verify is also disabled.

Note: 1. In the High-voltage Serial Programming mode, further programming of the fuse bits are also disabled. Program the fuse bits before programming the lock bits.

Fuse Bits in ATtiny11

The ATtiny11 has five fuse bits, FSTRT, RSTDISBL and CKSEL2..0.

- FSTRT: See Table 7, “Start-up Times for the ATtiny11 ($V_{CC} = 2.7V$),” on page 18 for which value to use. Default value is unprogrammed (“1”).
- When RSTDISBL is programmed (“0”), the external reset function of pin PB5 is disabled.⁽¹⁾ Default value is unprogrammed (“1”).
- CKSEL2..0: See Table 3, “Device Clocking Options Select,” on page 5, for which combination of CKSEL2..0 to use. Default value is “100”, internal RC oscillator.

The status of the fuse bits is not affected by Chip Erase.

Note: 1. If the RSTDISBL Fuse is programmed, then the programming hardware should apply +12V to PB5 while the ATtiny11 is in Power-on Reset. If not, the part can fail to enter programming mode caused by drive contention on PB0.

Fuse Bits in ATtiny12

The ATtiny12 has eight fuse bits, BODLEVEL, BODEN, SPIEN, RSTDISBL and CKSEL3..0. All the fuse bits are programmable in both High-voltage and Low-voltage Serial programming modes. Changing the fuses does not have any effect while in programming mode.

- The BODLEVEL Fuse selects the Brown-out Detection level and changes the start-up times. See “Brown-out Detection (ATtiny12)” on page 22. See Table 9, “ATtiny12 Clock Options and Start-up Times,” on page 20. Default value is programmed (“0”).
- When the BODEN Fuse is programmed (“0”), the Brown-out Detector is enabled. See “Brown-out Detection (ATtiny12)” on page 22. Default value is unprogrammed (“1”).
- When the SPIEN Fuse bit is programmed (“0”), Low-Voltage Serial Program and Data Downloading is enabled. Default value is programmed (“0”). Unprogramming this fuse while in the Low-Voltage Serial Programming mode will disable future in-system downloading attempts.
- When the RSTDISBL Fuse is programmed (“0”), the external reset function of pin PB5 is disabled.⁽¹⁾ Default value is unprogrammed (“1”). Programming this fuse while in the Low-Voltage Serial Programming mode will disable future in-system downloading attempts.

- CKSEL3..0 fuses: See Table 3, “Device Clocking Options Select,” on page 5 and Table 9, “ATtiny12 Clock Options and Start-up Times,” on page 20, for which combination of CKSEL3..0 to use. Default value is “0010”, internal RC oscillator with long start-up time.

The status of the fuse bits is not affected by Chip Erase.

Note: 1. If the RSTDISBL Fuse is programmed, then the programming hardware should apply +12V to PB5 while the ATtiny12 is in Power-on Reset. If not, the part can fail to enter programming mode caused by drive contention on PBO and/or PB5.

Signature Bytes

All Atmel microcontrollers have a three-byte signature code which identifies the device. The three bytes reside in a separate address space.

For the ATtiny11 they are:

1. \$000: \$1E (indicates manufactured by Atmel)
2. \$001: \$90 (indicates 1 Kb Flash memory)
3. \$002: \$04 (indicates ATtiny11 device when signature byte \$001 is \$90)

For the ATtiny12⁽¹⁾ they are:

1. \$000: \$1E (indicates manufactured by Atmel)
2. \$001: \$90 (indicates 1 Kb Flash memory)
3. \$002: \$05 (indicates ATtiny12 device when signature byte \$001 is \$90)

Note: 1. When both lock bits are programmed (Lock mode 3), the Signature Bytes can not be read in the Low-voltage Serial mode. Reading the Signature Bytes will return: \$00, \$01 and \$02.

Calibration Byte in ATtiny12

The ATtiny12 has a one-byte calibration value for the internal RC oscillator. This byte resides in the high byte of address \$000 in the signature address space. During memory programming, the external programmer must read this location and program its value into a selected location in the normal Flash Program memory. At start-up, the user software must read this Flash location and write the value to the OSCCAL register.

Programming the Flash and EEPROM

ATtiny11

Atmel's ATtiny11 offers 1K bytes of Flash Program memory.

The ATtiny11 is shipped with the on-chip Flash Program memory array in the erased state (i.e., contents = \$FF) and ready to be programmed.

This device supports a High-voltage (12V) Serial programming mode. Only minor currents (<1 mA) are drawn from the +12V pin during programming.

The program memory array in the ATtiny11 is programmed byte-by-byte.

ATtiny12

Atmel's ATtiny12 offers 1K bytes of in-system reprogrammable Flash Program memory and 64 bytes of in-system reprogrammable EEPROM Data memory.

The ATtiny12 is shipped with the on-chip Flash Program and EEPROM Data memory arrays in the erased state (i.e., contents = \$FF) and ready to be programmed.

This device supports a high-voltage (12V) serial programming mode and a low-voltage serial programming mode. The +12V is used for programming enable only, and no current of significance is drawn by this pin. The Low-voltage Serial Programming mode

provides a convenient way to download program and data into the ATtiny12 inside the user's system.

The program and data memory arrays in the ATtiny12 are programmed byte-by-byte in either programming mode. For the EEPROM, an auto-erase cycle is provided within the self-timed write instruction in the Low-voltage Serial Programming mode.

ATtiny11/12

During programming, the supply voltage must be in accordance with Table 22.

Table 22. Supply Voltage during Programming

Part	Low-voltage Serial Programming	High-voltage Serial Programming
ATtiny11L	Not applicable	4.5 - 5.5V
ATtiny11	Not applicable	4.5 - 5.5V
ATtiny12V	2.2 - 5.5V	4.5 - 5.5V
ATtiny12L	2.7 - 5.5V	4.5 - 5.5V
ATtiny12	4.0 - 5.5V	4.5 - 5.5V

High-voltage Serial Programming

This section describes how to program and verify Flash Program memory, EEPROM Data memory (ATtiny12), lock bits and fuse bits in the ATtiny11/12.

Figure 27. High-voltage Serial Programming

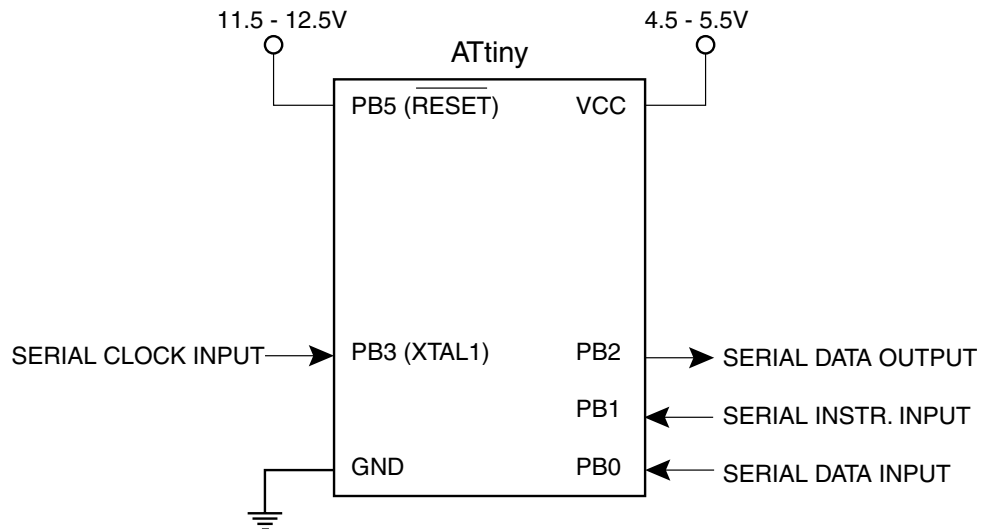

High-voltage Serial Programming Algorithm

To program and verify the ATtiny11/12 in the High-voltage Serial Programming mode, the following sequence is recommended (See instruction formats in Table 23):

1. Power-up sequence: Apply 4.5 - 5.5V between V_{CC} and GND. Set PB5 and PB0 to “0” and wait at least 100 ns. Toggle PB3 at least four times with minimum 100 ns pulse-width. Set PB3 to “0”. Wait at least 100 ns. Apply 12V to PB5 and wait at least 100 ns before changing PB0. Wait 8 μ s before giving any instructions.
2. The Flash array is programmed one byte at a time by supplying first the address, then the low and high data byte. The write instruction is self-timed, wait until the PB2 (RDY/BSY) pin goes high.
3. The EEPROM array (ATtiny12 only) is programmed one byte at a time by supplying first the address, then the data byte. The write instruction is self-timed, wait until the PB2 (RDY/ \overline{BSY}) pin goes high.
4. Any memory location can be verified by using the Read instruction which returns the contents at the selected address at serial output PB2.
5. Power-off sequence: Set PB3 to “0”.
Set PB5 to “1”.
Turn V_{CC} power off.

When writing or reading serial data to the ATtiny11/12, data is clocked on the rising edge of the serial clock, see Figure 28, Figure 29 and Table 24 for details.

Figure 28. High-voltage Serial Programming Waveforms

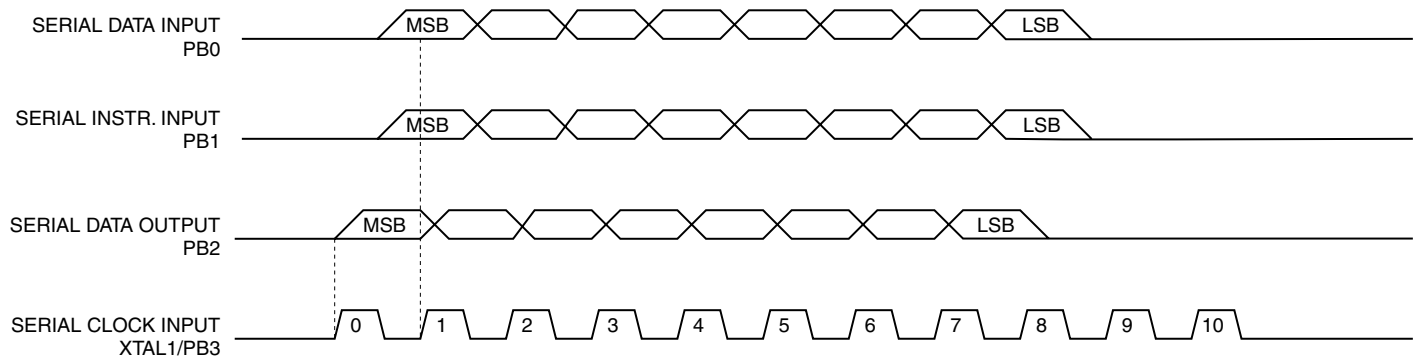

Table 23. High-voltage Serial Programming Instruction Set for ATtiny11/12

Instruction		Instruction Format				Operation Remarks
		Instr.1	Instr.2	Instr.3	Instr.4	
Chip Erase	PB0	0_1000_0000_00	0_0000_0000_00	0_0000_0000_00	0_0000_0000_00	Wait after Instr.4 until PB2 goes high for the Chip Erase cycle to finish.
	PB1	0_0100_1100_00	0_0110_0100_00	0_0110_1100_00	0_0100_1100_00	
	PB2	x_xxxx_xxxx_xx	x_xxxx_xxxx_xx	x_xxxx_xxxx_xx	x_xxxx_xxxx_xx	
Write Flash High and Low Address	PB0	0_0001_0000_00	0_0000_000a_00	0_bbbb_bbbb_00		Repeat Instr.2 for a new 256 byte page. Repeat Instr.3 for each new address.
	PB1	0_0100_1100_00	0_0001_1100_00	0_0000_1100_00		
	PB2	x_xxxx_xxxx_xx	x_xxxx_xxxx_xx	x_xxxx_xxxx_xx		
Write Flash Low byte	PB0	0_iiii_iiii_00	0_0000_0000_00	0_0000_0000_00		Wait after Instr.3 until PB2 goes high. Repeat Instr.1, Instr. 2 and Instr.3 for each new address.
	PB1	0_0010_1100_00	0_0110_0100_00	0_0110_1100_00		
	PB2	x_xxxx_xxxx_xx	x_xxxx_xxxx_xx	0_0000_0000_00		
Write Flash High byte	PB0	0_iiii_iiii_00	0_0000_0000_00	0_0000_0000_00		Wait after Instr.3 until PB2 goes high. Repeat Instr.1, Instr. 2 and Instr.3 for each new address.
	PB1	0_0011_1100_00	0_0111_0100_00	0_0111_1100_00		
	PB2	x_xxxx_xxxx_xx	x_xxxx_xxxx_xx	0_0000_0000_00		
Read Flash High and Low Address	PB0	0_0000_0010_00	0_0000_000a_00	0_bbbb_bbbb_00		Repeat Instr.2 and Instr.3 for each new address.
	PB1	0_0100_1100_00	0_0001_1100_00	0_0000_1100_00		
	PB2	x_xxxx_xxxx_xx	x_xxxx_xxxx_xx	x_xxxx_xxxx_xx		
Read Flash Low byte	PB0	0_0000_0000_00	0_0000_0000_00			Repeat Instr.1 and Instr.2 for each new address.
	PB1	0_0110_1000_00	0_0110_1100_00			
	PB2	x_xxxx_xxxx_xx	0_0000_000x_xx			
Read Flash High byte	PB0	0_0000_0000_00	0_0000_0000_00			Repeat Instr.1 and Instr.2 for each new address.
	PB1	0_0111_1000_00	0_0111_1100_00			
	PB2	x_xxxx_xxxx_xx	0_0000_000x_xx			
Write EEPROM Low Address (ATtiny12)	PB0	0_0001_0001_00	0_00bb_bbbb_00			Repeat Instr.2 for each new address.
	PB1	0_0100_1100_00	0_0000_1100_00			
	PB2	x_xxxx_xxxx_xx	x_xxxx_xxxx_xx			
Write EEPROM byte (ATtiny12)	PB0	0_iiii_iiii_00	0_0000_0000_00	0_0000_0000_00		Wait after Instr.3 until PB2 goes high
	PB1	0_0010_1100_00	0_0110_0100_00	0_0110_1100_00		
	PB2	x_xxxx_xxxx_xx	x_xxxx_xxxx_xx	0_0000_0000_00		
Read EEPROM Low Address (ATtiny12)	PB0	0_0000_0011_00	0_00bb_bbbb_00			Repeat Instr.2 for each new address.
	PB1	0_0100_1100_00	0_0000_1100_00			
	PB2	x_xxxx_xxxx_xx	x_xxxx_xxxx_xx			

Table 23. High-voltage Serial Programming Instruction Set for ATtiny11/12 (Continued)

Instruction		Instruction Format				Operation Remarks
		Instr.1	Instr.2	Instr.3	Instr.4	
Read EEPROM byte (ATtiny12)	PB0	0_0000_0000_00	0_0000_0000_00			Repeat Instr.2 for each new address
	PB1	0_0110_1000_00	0_0110_1100_00			
	PB2	x_xxxx_xxxx_xx	o_0000_000x_xx			
Write Fuse bits (ATtiny11)	PB0	0_0100_0000_00	0_0007_6543_00	0_0000_0000_00	0_0000_0000_00	Wait t_{WLWH_PFB} after Instr.3 for the Write fuse bits cycle to finish. Write 7 - 3 = "0" to program the fuse bit.
	PB1	0_0100_1100_00	0_0010_1100_00	0_0110_0100_00	0_0110_1100_00	
	PB2	x_xxxx_xxxx_xx	x_xxxx_xxxx_xx	x_xxxx_xxxx_xx	x_xxxx_xxxx_xx	
Write Fuse bits (ATtiny12)	PB0	0_0100_0000_00	0_CBA9_8543_00	0_0000_0000_00	0_0000_0000_00	Wait after Instr.4 until PB2 goes high. Write C - A, 9, 8, 5 - 3 = "0" to program the fuse bit.
	PB1	0_0100_1100_00	0_0010_1100_00	0_0110_0100_00	0_0110_1100_00	
	PB2	x_xxxx_xxxx_xx	x_xxxx_xxxx_xx	x_xxxx_xxxx_xx	x_xxxx_xxxx_xx	
Write Lock bits	PB0	0_0010_0000_00	0_0000_0210_00	0_0000_0000_00	0_0000_0000_00	Wait after Instr.4 until PB2 goes high. Write 2, 1 = "0" to program the lock bit.
	PB1	0_0100_1100_00	0_0010_1100_00	0_0110_0100_00	0_0110_1100_00	
	PB2	x_xxxx_xxxx_xx	x_xxxx_xxxx_xx	x_xxxx_xxxx_xx	0_0000_0000_00	
Read Fuse bits (ATtiny11)	PB0	0_0000_0100_00	0_0000_0000_00	0_0000_0000_00		Reading 7 - 3 = "0" means the fuse bit is programmed.
	PB1	0_0100_1100_00	0_0110_1000_00	0_0110_1100_00		
	PB2	x_xxxx_xxxx_xx	x_xxxx_xxxx_xx	x_x76_543x_xx		
Read Fuse bits (ATtiny12)	PB0	0_0000_0100_00	0_0000_0000_00	0_0000_0000_00		Reading C - A, 9, 8, 5 - 3 = "0" means the fuse bit is programmed.
	PB1	0_0100_1100_00	0_0110_1000_00	0_0110_1100_00		
	PB2	x_xxxx_xxxx_xx	x_xxxx_xxxx_xx	C_BA98_543x_xx		
Read Lock bits	PB0	0_0000_0100_00	0_0000_0000_00	0_0000_0000_00		Reading 2, 1 = "0" means the lock bit is programmed.
	PB1	0_0100_1100_00	0_0111_1000_00	0_0111_1100_00		
	PB2	x_xxxx_xxxx_xx	x_xxxx_xxxx_xx	x_xxxx_21xx_xx		
Read Signature Bytes	PB0	0_0000_1000_00	0_0000_00bb_00	0_0000_0000_00	0_0000_0000_00	Repeat Instr.2 - Instr.4 for each signature byte address
	PB1	0_0100_1100_00	0_0000_1100_00	0_0110_1000_00	0_0110_1100_00	
	PB2	x_xxxx_xxxx_xx	x_xxxx_xxxx_xx	x_xxxx_xxxx_xx	o_0000_000x_xx	
Read Calibration Byte (ATtiny12)	PB0	0_0000_1000_00	0_0000_0000_00	0_0000_0000_00	0_0000_0000_00	
	PB1	0_0100_1100_00	0_0000_1100_00	0_0111_1000_00	0_0111_1100_00	
	PB2	x_xxxx_xxxx_xx	x_xxxx_xxxx_xx	x_xxxx_xxxx_xx	o_0000_000x_xx	

Note:

- a = address high bits
- b = address low bits
- i = data in
- o = data out
- x = don't care
- 1 = Lock Bit1
- 2 = Lock Bit2
- 3 = CKSEL0 Fuse
- 4 = CKSEL1 Fuse
- 5 = CKSEL2 Fuse
- 9, 6 = RSTDISBL Fuse
- 7 = FSTRT Fuse
- 8 = CKSEL3 Fuse
- A = SPIEN Fuse
- B = BODEN Fuse
- C = BODLEVEL Fuse



High-voltage Serial Programming Characteristics

Figure 29. High-voltage Serial Programming Timing

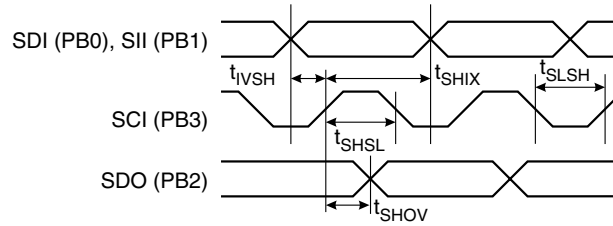

Table 24. High-voltage Serial Programming Characteristics $T_A = 25^\circ\text{C} \pm 10\%$, $V_{CC} = 5.0\text{V} \pm 10\%$ (Unless otherwise noted)

Symbol	Parameter	Min	Typ	Max	Units
t_{SHSL}	SCI (PB3) Pulse Width High	100			ns
t_{SLSH}	SCI (PB3) Pulse Width Low	100			ns
t_{IVSH}	SDI (PB0), SII (PB1) Valid to SCI (PB3) High	50			ns
t_{SHIX}	SDI (PB0), SII (PB1) Hold after SCI (PB3) High	50			ns
t_{SHOV}	SCI (PB3) High to SDO (PB2) Valid	10	16	32	ns
t_{WLWH_PFB}	Wait after Instr. 3 for Write Fuse Bits	1.7	2.5	3.4	ms

Low-voltage Serial Downloading (ATtiny12 only)

Both the program and data memory arrays can be programmed using the SPI bus while $\overline{\text{RESET}}$ is pulled to GND. The serial interface consists of pins SCK, MOSI (input) and MISO (output), see Figure 30. After $\overline{\text{RESET}}$ is set low, the Programming Enable instruction needs to be executed first before program/erase instructions can be executed.

Figure 30. Serial Programming and Verify

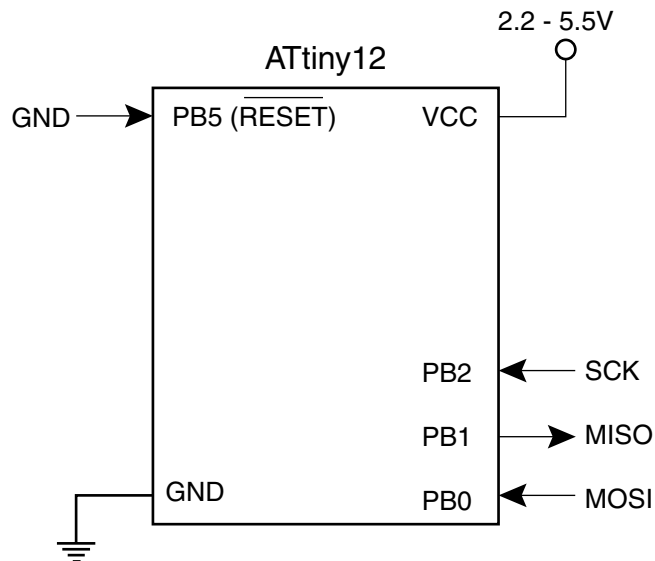

If the chip Erase command in Low-voltage Serial Programming is executed only once, one data byte may be written to the flash after erase. Using the following algorithm guarantees that the flash will be erased:

- Execute a chip erase command
- Write \$FF to address \$00 in the flash
- Execute a second chip erase command

For the EEPROM, an auto-erase cycle is provided within the self-timed write instruction and there is no need to first execute the Chip Erase instruction. The Chip Erase instruction turns the content of every memory location in both the program and EEPROM arrays into \$FF.

The program and EEPROM memory arrays have separate address spaces:

\$0000 to \$01FF for program memory and \$000 to \$03F for EEPROM memory.

The device can be clocked by any clock option during Low-voltage Serial Programming. The minimum low and high periods for the serial clock (SCK) input are defined as follows:

Low: > 2 MCU clock cycles

High: > 2 MCU clock cycles

Low-voltage Serial Programming Algorithm

When writing serial data to the ATtiny12, data is clocked on the rising edge of SCK. When reading data from the ATtiny12, data is clocked on the falling edge of SCK. See Figure 31, Figure 32 and Table 26 for timing details. To program and verify the ATtiny12 in the serial programming mode, the following sequence is recommended (See 4 byte instruction formats in Table 25):

1. Power-up sequence:

Apply power between VCC and GND while RESET and SCK are set to “0”. In accordance with the setting of CKSEL fuses, apply a crystal/resonator, external clock or RC network, or let the device run on the internal RC oscillator. In some systems, the programmer can not guarantee that SCK is held low during power-up. In this case, $\overline{\text{RESET}}$ must be given a positive pulse of at least two MCU cycles duration after SCK has been set to “0”.
2. Wait for at least 20 ms and enable serial programming by sending the Programming Enable Serial instruction to the MOSI (PB0) pin.
3. The serial programming instructions will not work if the communication is out of synchronization. When in sync, the second byte (\$53) will echo back when issuing the third byte of the Programming Enable instruction. Whether the echo is correct or not, all 4 bytes of the instruction must be transmitted. If the \$53 did not echo back, give SCK a positive pulse and issue a new Programming Enable instruction. If the \$53 is not seen within 32 attempts, there is no functional device connected.
4. If a Chip Erase is performed (must be done to erase the Flash), wait $t_{\text{WD_ERASE}}$ after the instruction, give $\overline{\text{RESET}}$ a positive pulse, and start over from Step 2. See Table 27 on page 54 for $t_{\text{WD_ERASE}}$ value.
5. The Flash or EEPROM array is programmed one byte at a time by supplying the address and data together with the appropriate Write instruction. An EEPROM memory location is first automatically erased before new data is written. Use Data Polling to detect when the next byte in the Flash or EEPROM can be written. If polling is not used, wait $t_{\text{WD_FLASH}}$ or $t_{\text{WD_EEPROM}}$ before transmitting the

next instruction. See Table 28 on page 54 for t_{WD_FLASH} and t_{WD_EEPROM} values. In an erased device, no \$FFs in the data file(s) needs to be programmed.

6. Any memory location can be verified by using the Read instruction which returns the content at the selected address at the serial output MISO (PB1) pin.
7. At the end of the programming session, \overline{RESET} can be set high to commence normal operation.
8. Power-off sequence (if needed):
 - Set XTAL1 to "0" (if external clocking is used).
 - Set \overline{RESET} to "1".
 - Turn V_{CC} power off.

Data Polling

When a byte is being programmed into the Flash or EEPROM, reading the address location being programmed will give the value \$FF. At the time the device is ready for a new byte, the programmed value will read correctly. This is used to determine when the next byte can be written. This will not work for the value \$FF, so when programming this value, the user will have to wait for at least t_{WD_FLASH} or t_{WD_EEPROM} before programming the next byte. As a chip-erased device contains \$FF in all locations, programming of addresses that are meant to contain \$FF can be skipped. This does not apply if the EEPROM is reprogrammed without chip-erasing the device. In that case, data polling cannot be used for the value \$FF, and the user will have to wait at least t_{WD_EEPROM} before programming the next byte. See Table 28 for t_{WD_FLASH} and t_{WD_EEPROM} values.

Figure 31. Low-voltage Serial Programming Waveforms

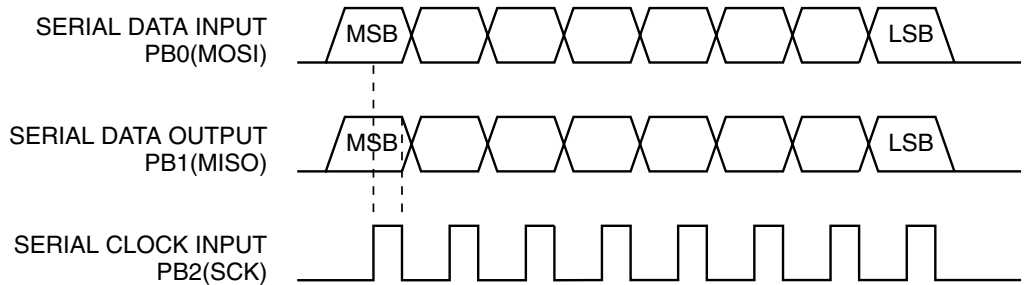

Table 25. Low-voltage Serial Programming Instruction Set

Instruction	Instruction Format				Operation
	Byte 1	Byte 2	Byte 3	Byte 4	
Programming Enable	1010 1100	0101 0011	xxxx xxxx	xxxx xxxx	Enable serial programming while <u>RESET</u> is low.
Chip Erase	1010 1100	100x xxxx	xxxx xxxx	xxxx xxxx	Chip erase Flash and EEPROM memory arrays.
Read Program Memory	0010 H000	xxxx xxxa	bbbb bbbb	oooo oooo	Read H (high or low) data o from program memory at word address a:b.
Write Program Memory	0100 H000	xxxx xxxa	bbbb bbbb	iiii iiiii	Write H (high or low) data i to program memory at word address a:b.
Read EEPROM Memory	1010 0000	xxxx xxxx	xxbb bbbb	oooo oooo	Read data o from EEPROM memory at address b.
Write EEPROM Memory	1100 0000	xxxx xxxx	xxbb bbbb	iiii iiiii	Write data i to EEPROM memory at address b.
Write Lock Bits	1010 1100	1111 1211	xxxx xxxx	xxxx xxxx	Write lock bits. Set bits 1,2 = "0" to program lock bits.
Read Lock Bits	0101 1000	xxxx xxxx	xxxx xxxx	xxxx x21x	Read lock bits. "0" = programmed, "1" = unprogrammed.
Read Signature Bytes	0011 0000	xxxx xxxx	0000 00bb	oooo oooo	Read signature byte o at address b. ⁽¹⁾
Read Calibration Byte	0011 1000	xxxx xxxx	0000 0000	oooo oooo	
Write Fuse Bits	1010 1100	101x xxxx	xxxx xxxx	A987 6543	Set bits A, 9 - 3 = "0" to program, "1" to unprogram.
Read Fuse Bits	0101 0000	xxxx xxxx	xxxx xxxx	A987 6543	Read fuse bits. "0" = programmed, "1" = unprogrammed.

Note: a = address high bits
b = address low bits
H = 0 - Low byte, 1 - High byte
o = data out
i = data in
x = don't care
1 = Lock bit 1
2 = Lock bit 2
3 = CKSEL0 Fuse
4 = CKSEL1 Fuse
5 = CKSEL2 Fuse
6 = CKSEL3 Fuse
7 = RSTDISBL Fuse
8 = SPIEN Fuse
9 = BODEN Fuse
A = BODLEVEL Fuse

Note: 1. The signature bytes are not readable in Lock mode 3, i.e. both lock bits programmed.



Low-voltage Serial Programming Characteristics

Figure 32. Low-voltage Serial Programming Timing

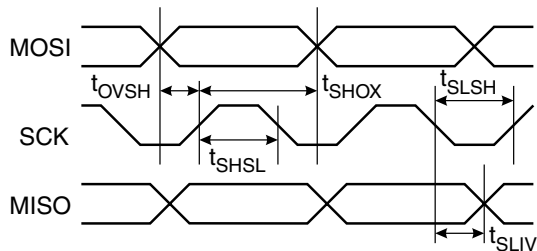

Table 26. Low-voltage Serial Programming Characteristics $T_A = -40^\circ\text{C}$ to 85°C , $V_{CC} = 2.2 - 5.5\text{V}$ (Unless otherwise noted)

Symbol	Parameter	Min	Typ	Max	Units
$1/t_{CLCL}$	Oscillator Frequency ($V_{CC} = 2.2 - 2.7\text{V}$)	0		1	MHz
t_{CLCL}	Oscillator Period ($V_{CC} = 2.2 - 2.7\text{V}$)	1000			ns
$1/t_{CLCL}$	Oscillator Frequency ($V_{CC} = 2.7 - 4.0\text{V}$)	0		4	MHz
t_{CLCL}	Oscillator Period ($V_{CC} = 2.7 - 4.0\text{V}$)	250			ns
$1/t_{CLCL}$	Oscillator Frequency ($V_{CC} = 4.0 - 5.5\text{V}$)	0		8	MHz
t_{CLCL}	Oscillator Period ($V_{CC} = 4.0 - 5.5\text{V}$)	125			ns
t_{SHSL}	SCK Pulse Width High	$2 t_{CLCL}$			ns
t_{SLSH}	SCK Pulse Width Low	$2 t_{CLCL}$			ns
t_{OVSH}	MOSI Setup to SCK High	t_{CLCL}			ns
t_{SHOX}	MOSI Hold after SCK High	$2 t_{CLCL}$			ns
t_{SLIV}	SCK Low to MISO Valid	10	16	32	ns

Table 27. Minimum Wait Delay after the Chip Erase Instruction

Symbol	Minimum Wait Delay
t_{WD_ERASE}	6.8 ms

Table 28. Minimum Wait Delay after Writing a Flash or EEPROM Location

Symbol	Minimum Wait Delay
t_{WD_FLASH}	3.4 ms
t_{WD_EEPROM}	6.8 ms

Electrical Characteristics

Absolute Maximum Ratings

Operating Temperature.....	-55°C to +125°C
Storage Temperature.....	-65°C to +150°C
Voltage on any Pin except $\overline{\text{RESET}}$ with respect to Ground	-1.0V to $V_{CC}+0.5V$
Voltage on $\overline{\text{RESET}}$ with respect to Ground.....	-1.0V to +13.0V
Maximum Operating Voltage	6.0V
DC Current per I/O Pin	40.0 mA
DC Current V_{CC} and GND Pins.....	100.0 mA

*NOTICE: Stresses beyond those ratings listed under “Absolute Maximum Ratings” may cause permanent damage to the device. This is a stress rating only and functional operation of the device at these or other conditions beyond those indicated in the operational sections of this specification is not implied. Exposure to absolute maximum rating conditions for extended periods may affect device reliability.

DC Characteristics – Preliminary Data

$T_A = -40^\circ\text{C}$ to 85°C , $V_{CC} = 2.7V$ to $5.5V$ for ATtiny11, $V_{CC} = 1.8V$ to $5.5V$ for ATtiny12 (Unless otherwise noted)

Symbol	Parameter	Condition	Min	Typ	Max	Units
V_{IL}	Input Low Voltage	Except (XTAL)	-0.5		$0.3 V_{CC}^{(1)}$	V
V_{IL1}	Input Low Voltage	XTAL	-0.5		$0.1 V_{CC}^{(1)}$	V
V_{IH}	Input High Voltage	Except (XTAL, $\overline{\text{RESET}}$)	$0.6 V_{CC}^{(2)}$		$V_{CC} + 0.5$	V
V_{IH1}	Input High Voltage	XTAL	$0.7 V_{CC}^{(2)}$		$V_{CC} + 0.5$	V
V_{IH2}	Input High Voltage	$\overline{\text{RESET}}$	$0.85 V_{CC}^{(2)}$		$V_{CC} + 0.5$	V
V_{OL}	Output Low Voltage ⁽³⁾ Port B	$I_{OL} = 20 \text{ mA}$, $V_{CC} = 5V$			0.6	V
		$I_{OL} = 10 \text{ mA}$, $V_{CC} = 3V$			0.5	V
V_{OL}	Output Low Voltage PB5 (ATtiny12)	$I_{OL} = 12 \text{ mA}$, $V_{CC} = 5V$			0.6	V
		$I_{OL} = 6 \text{ mA}$, $V_{CC} = 3V$			0.5	V
V_{OH}	Output High Voltage ⁽⁴⁾ Port B	$I_{OH} = -3 \text{ mA}$, $V_{CC} = 5V$	4.3			V
		$I_{OH} = -1.5 \text{ mA}$, $V_{CC} = 3V$	2.3			V
I_{IL}	Input Leakage Current I/O Pin	$V_{CC} = 5.5V$, Pin Low (Absolute value)			8.0	μA
I_{IH}	Input Leakage Current I/O Pin	$V_{CC} = 5.5V$, Pin High (Absolute value)			8.0	μA
$R_{I/O}$	I/O Pin Pull-Up		35		122	$k\Omega$



DC Characteristics – Preliminary Data (Continued)

$T_A = -40^{\circ}\text{C}$ to 85°C , $V_{CC} = 2.7\text{V}$ to 5.5V for ATtiny11, $V_{CC} = 1.8\text{V}$ to 5.5V for ATtiny12 (Unless otherwise noted)

Symbol	Parameter	Condition	Min	Typ	Max	Units	
I_{CC}	Power Supply Current	Active 1 MHz, $V_{CC} = 3\text{V}$ (ATtiny12V)			1.0	mA	
		Active 2 MHz, $V_{CC} = 3\text{V}$ (ATtiny11L)			2.0	mA	
		Active 4 MHz, $V_{CC} = 3\text{V}$ (ATtiny12L)			2.5	mA	
		Active 6 MHz, $V_{CC} = 5\text{V}$ (ATtiny11)			10	mA	
		Active 8 MHz, $V_{CC} = 5\text{V}$ (ATtiny12)			10	mA	
		Idle 1 MHz, $V_{CC} = 3\text{V}$ (ATtiny12V)			0.4	mA	
		Idle 2 MHz, $V_{CC} = 3\text{V}$ (ATtiny11L)			0.5	mA	
		Idle 4 MHz, $V_{CC} = 3\text{V}$ (ATtiny12L)			1.0	mA	
		Idle 6 MHz, $V_{CC} = 5\text{V}$ (ATtiny11)			2.0	mA	
		Idle 8 MHz, $V_{CC} = 5\text{V}$ (ATtiny12)			3.5	mA	
		Power Down ⁽⁵⁾ , $V_{CC} = 3\text{V}$, WDT enabled			9.0	15	μA
		Power Down ⁽⁵⁾ , $V_{CC} = 3\text{V}$. WDT disabled (ATtiny12)			<1	2	μA
		Power Down ⁽⁵⁾ , $V_{CC} = 3\text{V}$. WDT disabled (ATtiny11)			<1	5	μA
V_{ACIO}	Analog Comparator Input Offset Voltage	$V_{CC} = 5\text{V}$ $V_{IN} = V_{CC}/2$			40	mV	
I_{ACLK}	Analog Comparator Input Leakage Current	$V_{CC} = 5\text{V}$ $V_{IN} = V_{CC}/2$	-50		50	nA	
T_{ACPD}	Analog Comparator Propagation Delay	$V_{CC} = 2.7\text{V}$ $V_{CC} = 4.0\text{V}$		750 500		ns	

- Notes:
1. "Max" means the highest value where the pin is guaranteed to be read as low.
 2. "Min" means the lowest value where the pin is guaranteed to be read as high.
 3. Although each I/O port can sink more than the test conditions (20 mA at $V_{CC} = 5\text{V}$, 10 mA at $V_{CC} = 3\text{V}$) under steady state conditions (non-transient), the following must be observed:
 - 1] The sum of all I_{OL} , for all ports, should not exceed 100 mA.
 If I_{OL} exceeds the test condition, V_{OL} may exceed the related specification. Pins are not guaranteed to sink current greater than the listed test conditions.
 4. Although each I/O port can source more than the test conditions (3 mA at $V_{CC} = 5\text{V}$, 1.5 mA at $V_{CC} = 3\text{V}$) under steady state conditions (non-transient), the following must be observed:
 - 1] The sum of all I_{OH} , for all ports, should not exceed 100 mA.
 If I_{OH} exceeds the test condition, V_{OH} may exceed the related specification. Pins are not guaranteed to source current greater than the listed test condition.
 5. Minimum V_{CC} for Power-down is 1.5V. (On ATtiny12: only with BOD disabled)

External Clock Drive Waveforms

Figure 33. External Clock

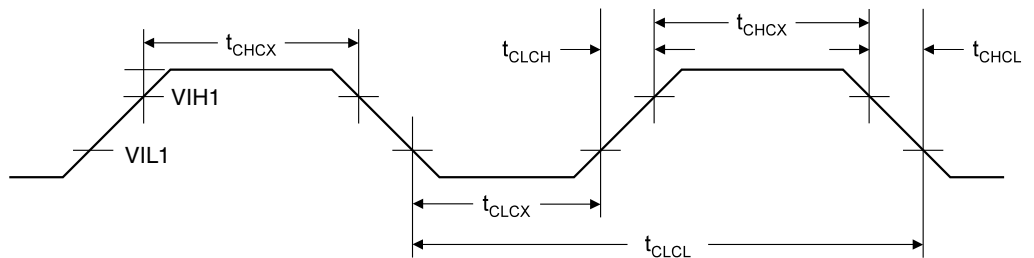

External Clock Drive ATtiny11

Symbol	Parameter	V _{CC} = 2.7V to 4.0V		V _{CC} = 4.0V to 5.5V		Units
		Min	Max	Min	Max	
1/t _{CLCL}	Oscillator Frequency	0	2	0	6	MHz
t _{CLCL}	Clock Period	500		167		ns
t _{CHCX}	High Time	200		67		ns
t _{CLCX}	Low Time	200		67		ns
t _{CLCH}	Rise Time		1.6		0.5	μs
t _{CHCL}	Fall Time		1.6		0.5	μs

External Clock Drive ATtiny12

Symbol	Parameter	V _{CC} = 1.8V to 2.7V		V _{CC} = 2.7V to 4.0V		V _{CC} = 4.0V to 5.5V		Units
		Min	Max	Min	Max	Min	Max	
1/t _{CLCL}	Oscillator Frequency	0	1.2	0	4	0	8	MHz
t _{CLCL}	Clock Period	833		250		125		ns
t _{CHCX}	High Time	333		100		50		ns
t _{CLCX}	Low Time	333		100		50		ns
t _{CLCH}	Rise Time		1.6		1.6		0.5	μs
t _{CHCL}	Fall Time		1.6		1.6		0.5	μs

Table 29. External RC Oscillator, Typical Frequencies

R [kΩ]	C [pF]	f
100	70	100 kHz
31.5	20	1.0 MHz
6.5	20	4.0 MHz

Note: R should be in the range 3-100 kΩ, and C should be at least 20 pF. The C values given in the table includes pin capacitance. This will vary with package type.

ATtiny11 Typical Characteristics

The following charts show typical behavior. These figures are not tested during manufacturing. All current consumption measurements are performed with all I/O pins configured as inputs and with internal pull-ups enabled. A sine wave generator with rail-to-rail output is used as clock source.

The power consumption in Power-down Mode is independent of clock selection.

The current consumption is a function of several factors such as: operating voltage, operating frequency, loading of I/O pins, switching rate of I/O pins, code executed and ambient temperature. The dominating factors are operating voltage and frequency.

The current drawn from capacitive loaded pins may be estimated (for one pin) as $C_L * V_{CC} * f$ where C_L = load capacitance, V_{CC} = operating voltage and f = average switching frequency of I/O pin.

The parts are characterized at frequencies higher than test limits. Parts are not guaranteed to function properly at frequencies higher than the ordering code indicates.

The difference between current consumption in Power-down Mode with Watchdog Timer enabled and Power-down Mode with Watchdog Timer disabled represents the differential current drawn by the Watchdog timer.

Figure 34. Active Supply Current vs. Frequency

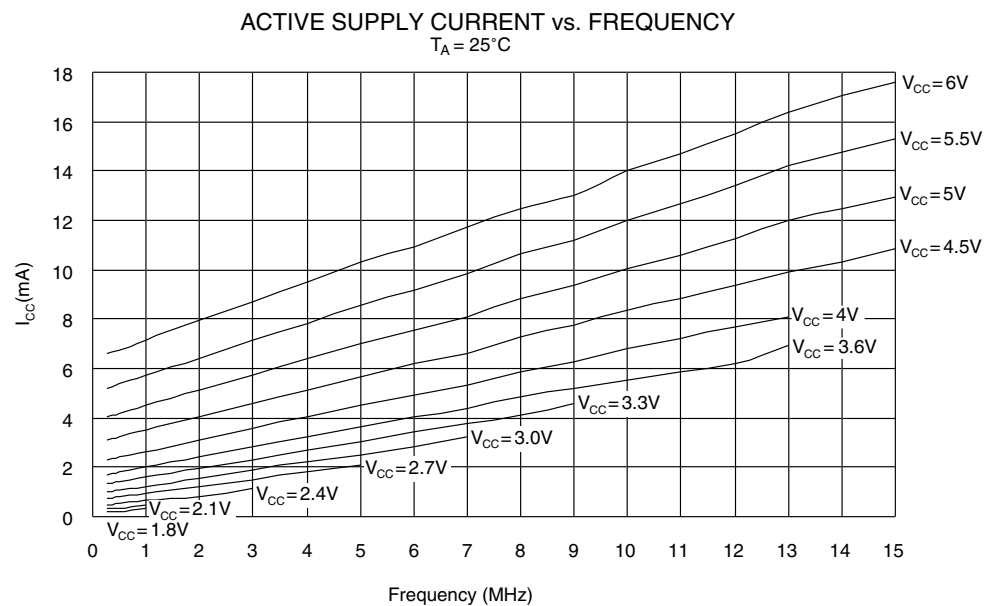

Figure 35. Active Supply Current vs. V_{CC}

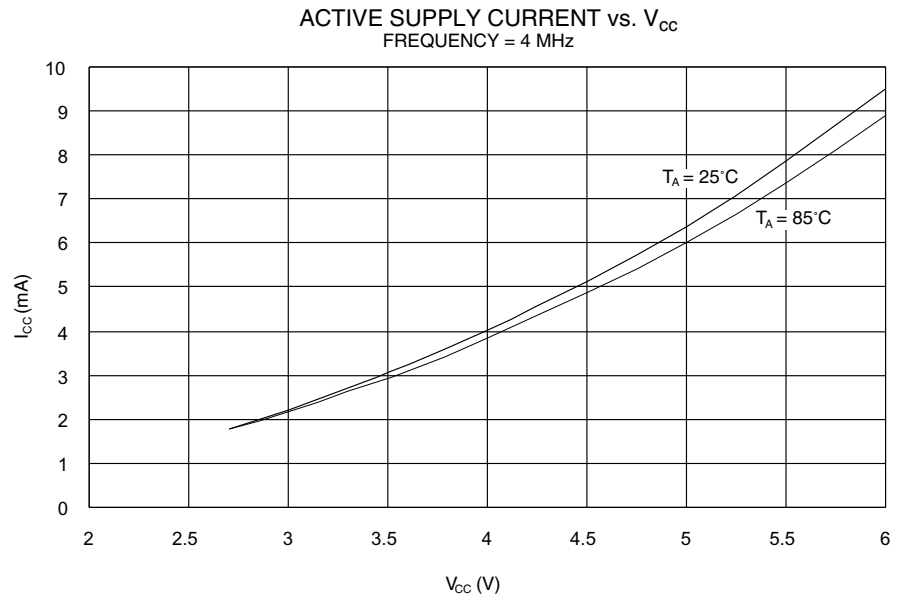

Figure 36. Active Supply Current vs. V_{CC} , Device Clocked by Internal Oscillator

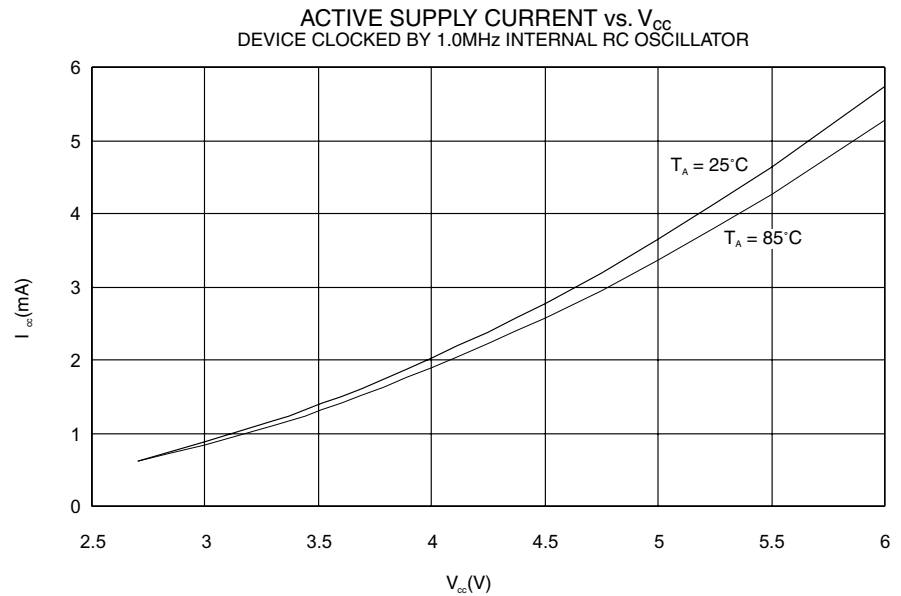

Figure 37. Active Supply Current vs. V_{CC} , Device Clocked by External 32kHz Crystal

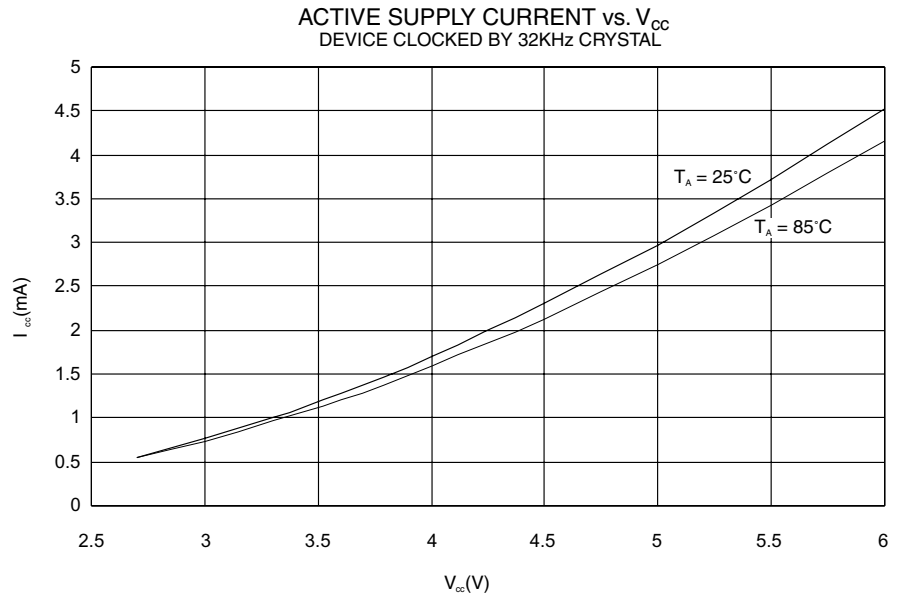

Figure 38. Idle Supply Current vs. Frequency

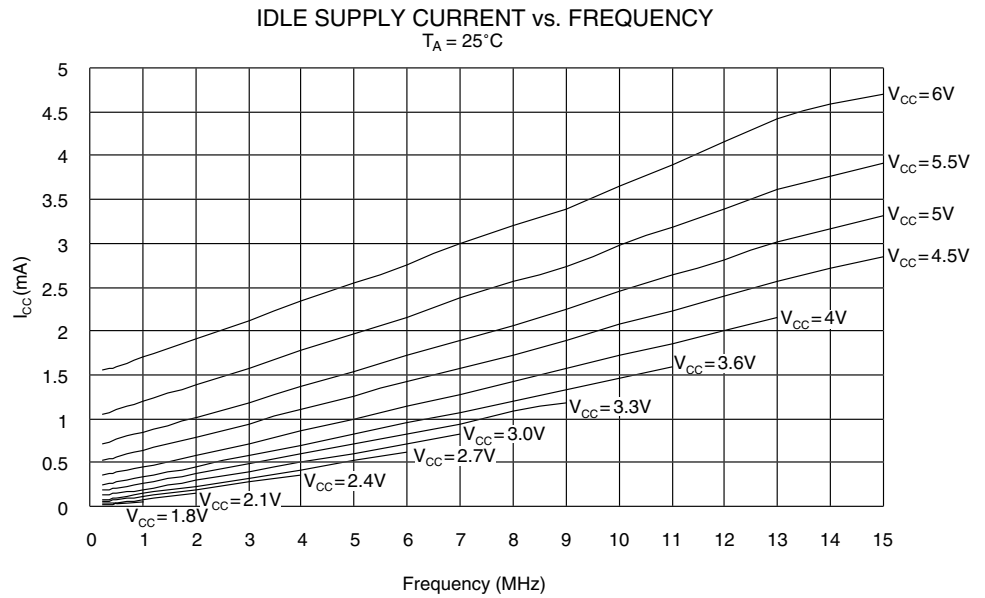

Figure 39. Idle Supply Current vs. V_{CC}

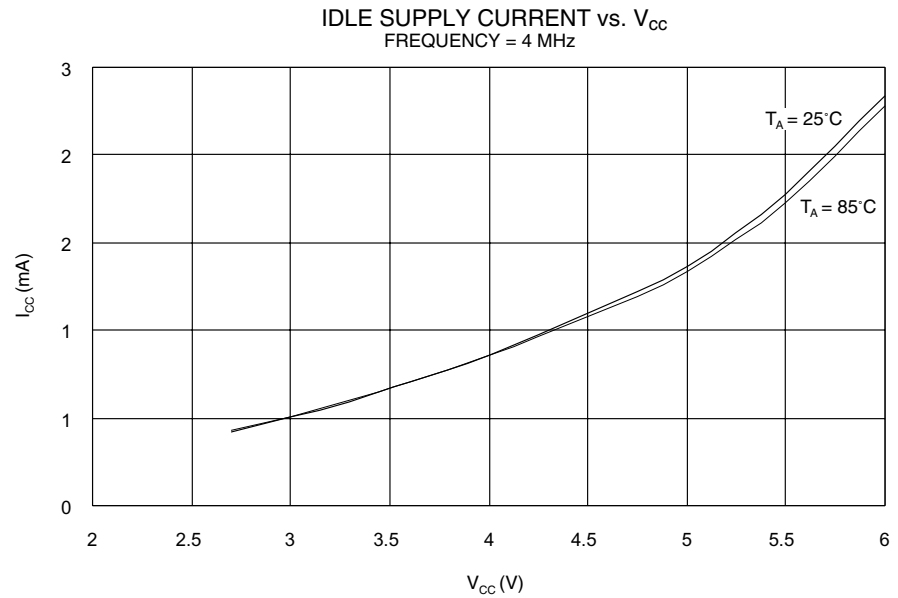

Figure 40. Idle Supply Current vs. V_{CC} , Device Clocked by Internal Oscillator

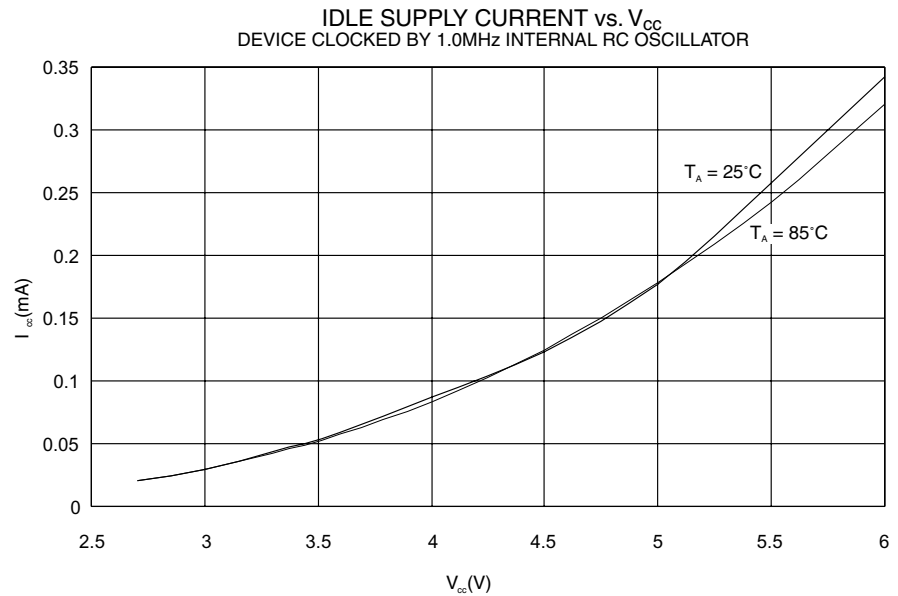

Figure 41. Idle Supply Current vs. V_{CC} , Device Clocked by External 32kHz Crystal

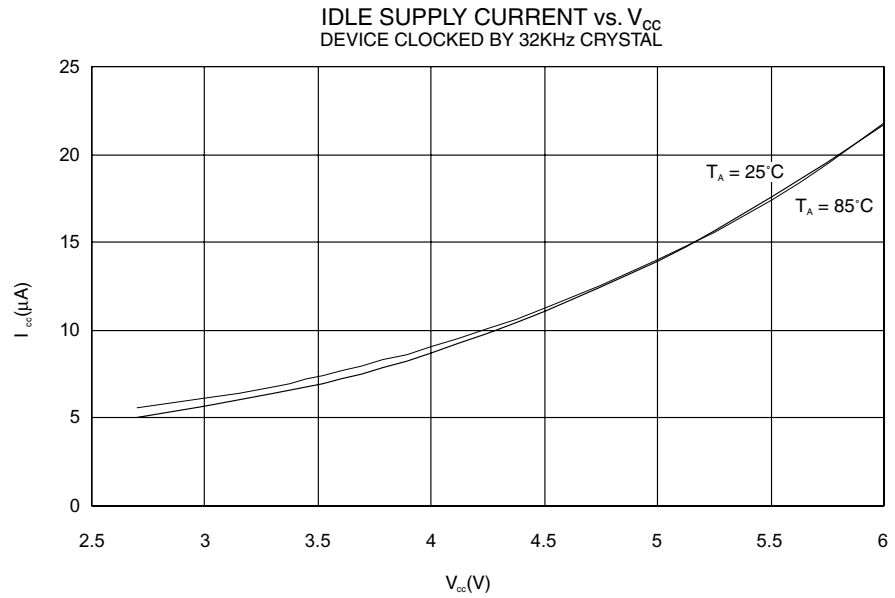

Figure 42. Power-down Supply Current vs. V_{CC}

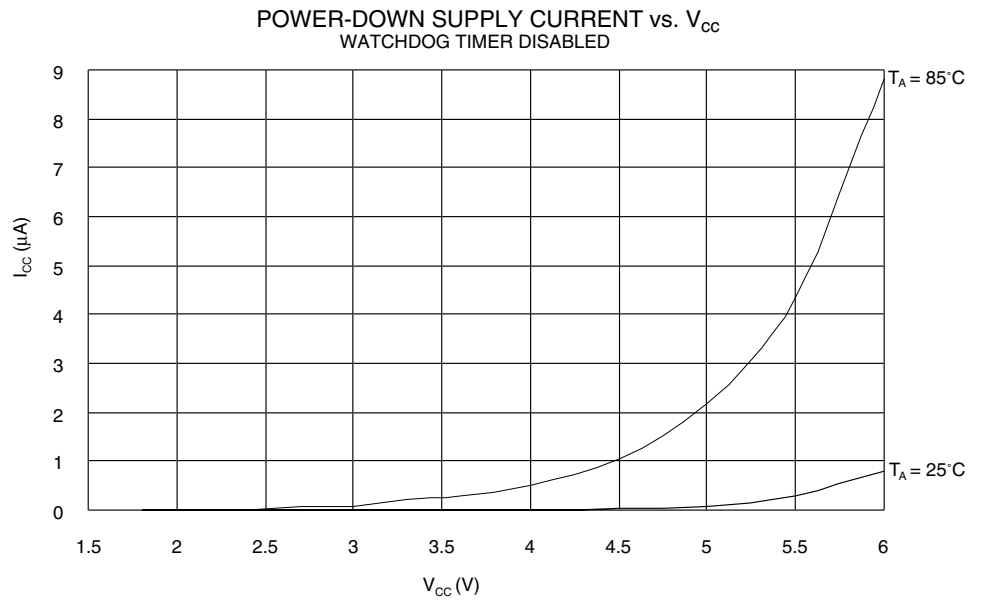

Figure 43. Power-down Supply Current vs. V_{CC}

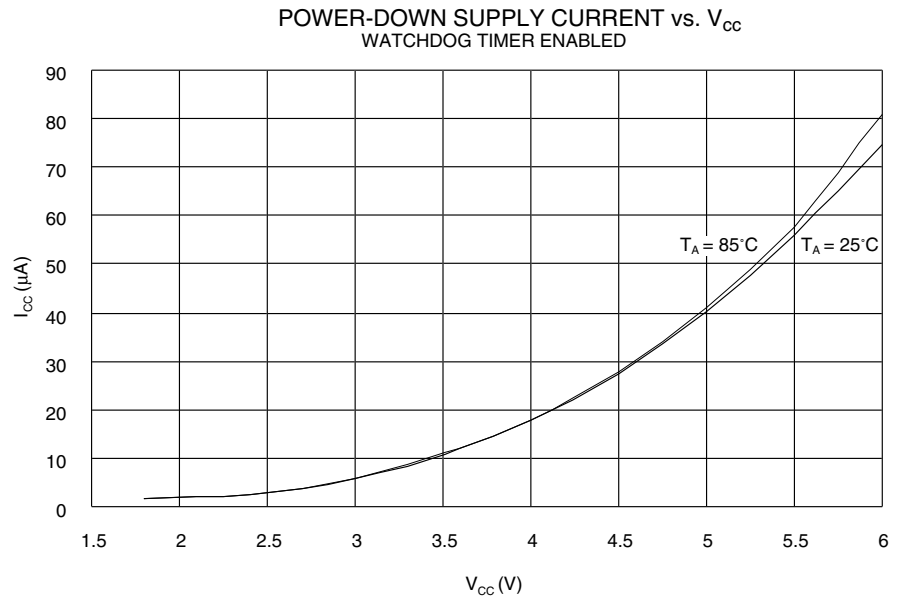
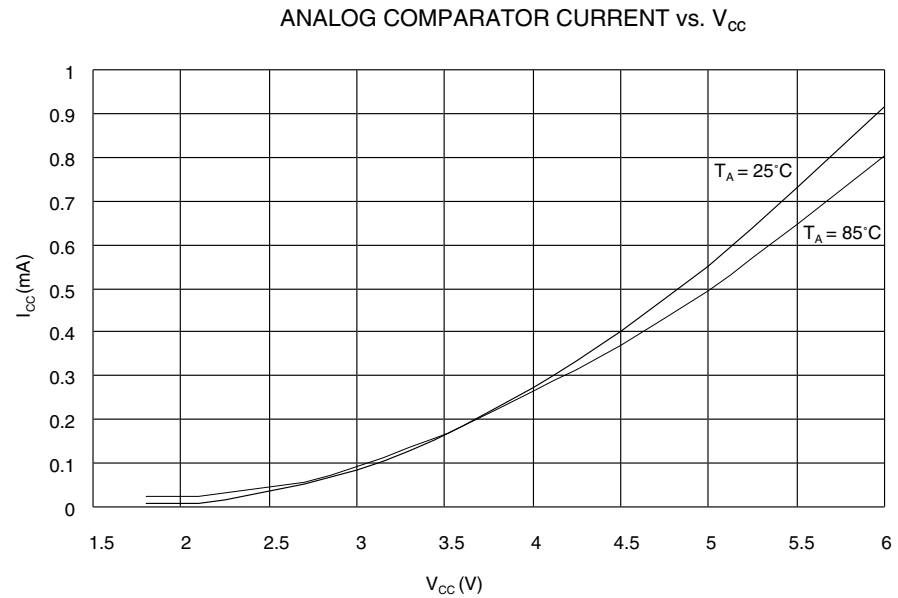

Figure 44. Analog Comparator Current vs. V_{CC}



Analog comparator offset voltage is measured as absolute offset.

Figure 45. Analog Comparator Offset Voltage vs. Common Mode Voltage

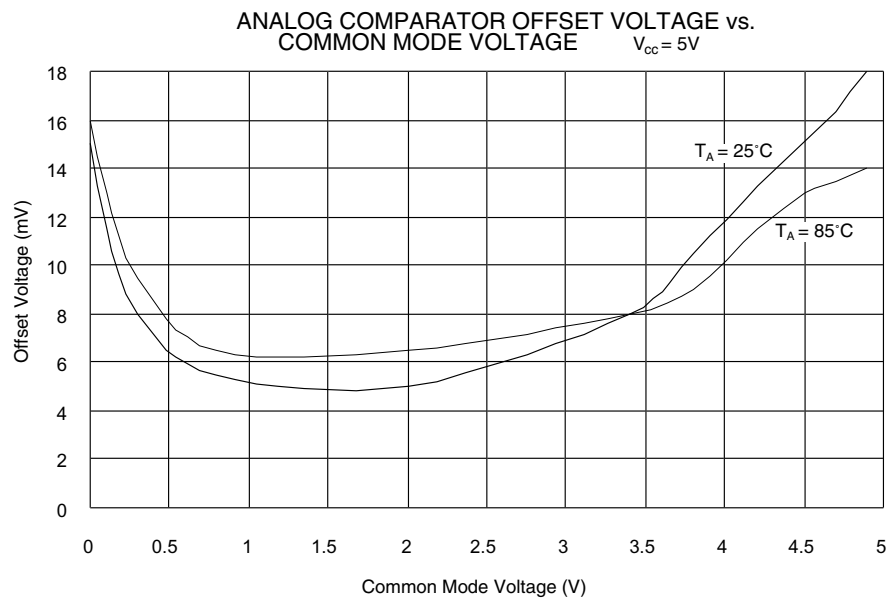

Figure 46. Analog Comparator Offset Voltage vs. Common Mode Voltage

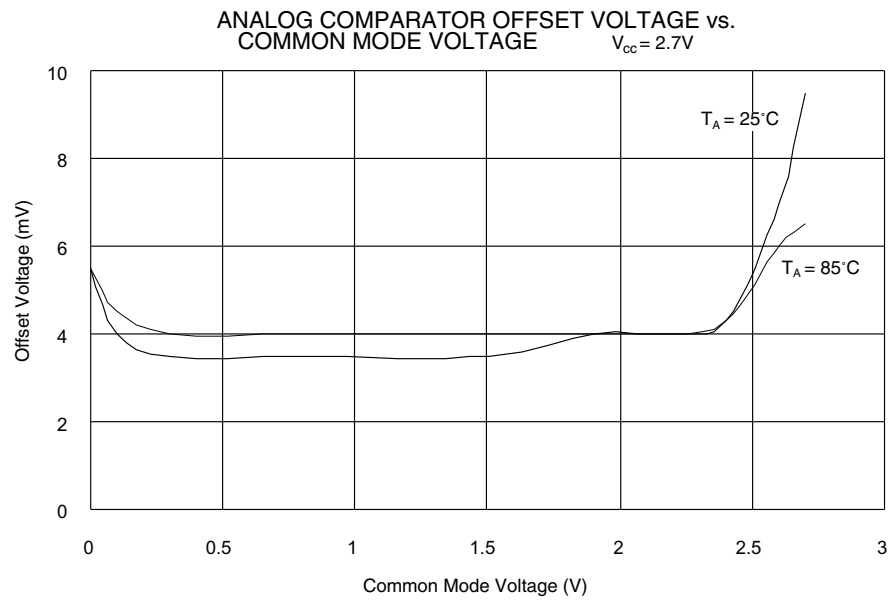

Figure 47. Analog Comparator Input Leakage Current

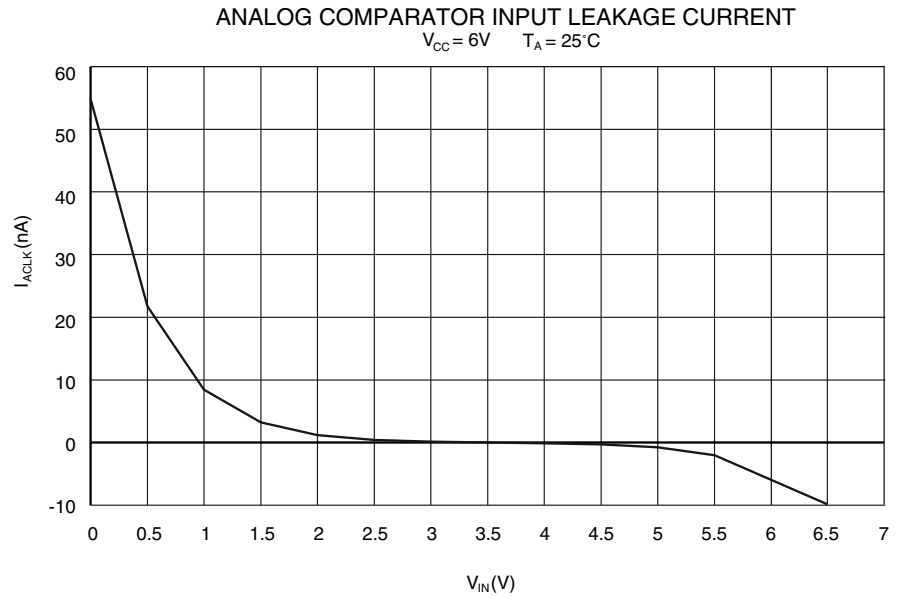
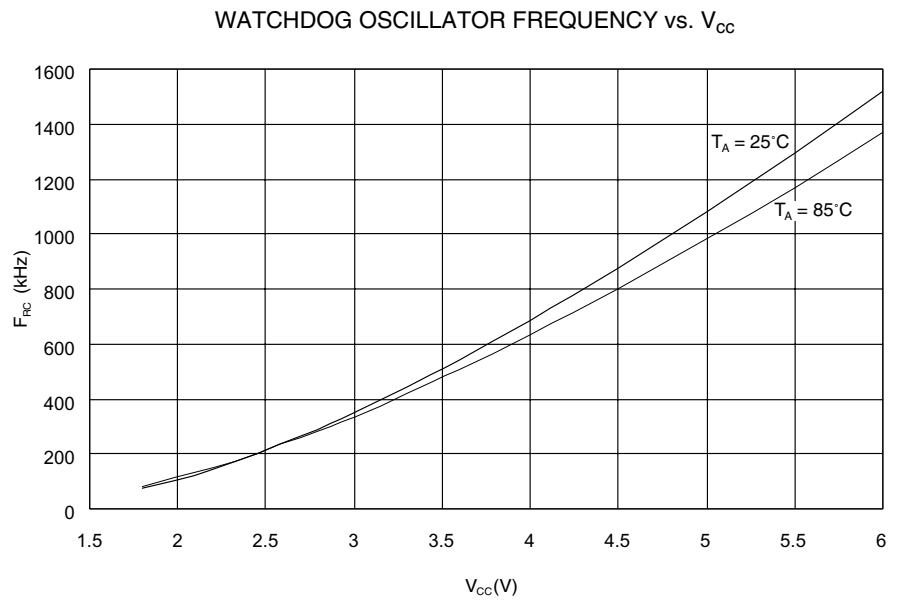

Figure 48. Watchdog Oscillator Frequency vs. V_{CC}



Sink and source capabilities of I/O ports are measured on one pin at a time.

Figure 49. Pull-up Resistor Current vs. Input Voltage

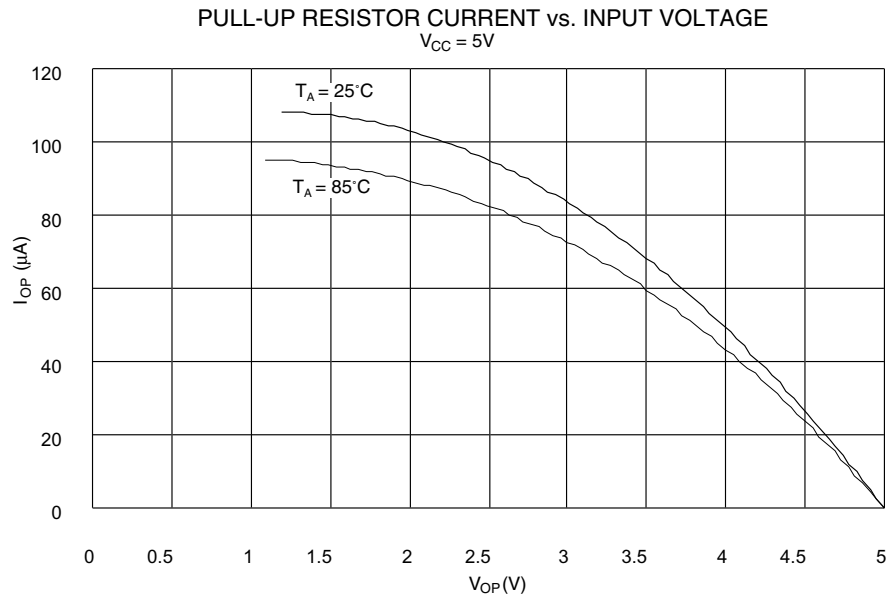

Figure 50. Pull-up Resistor Current vs. Input Voltage

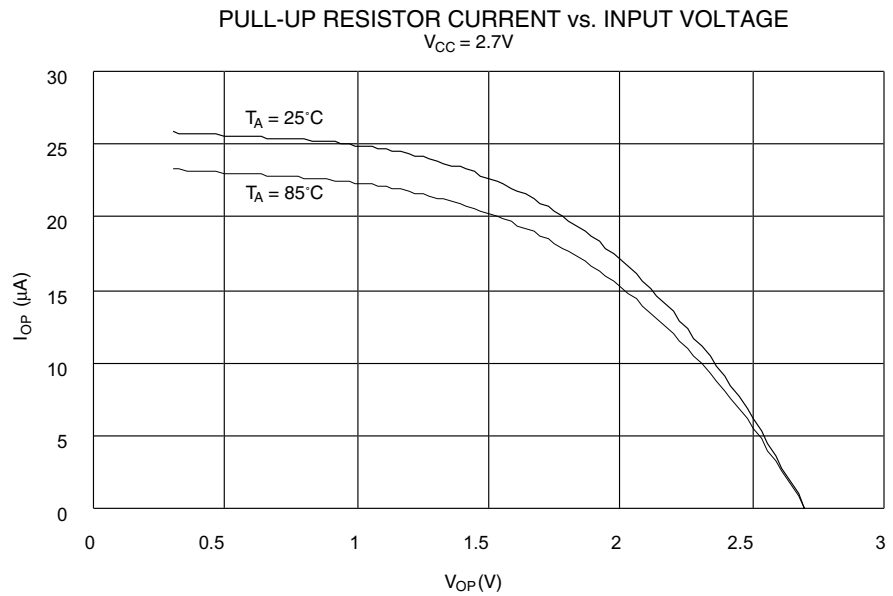

Figure 51. I/O Pin Sink Current vs. Output Voltage

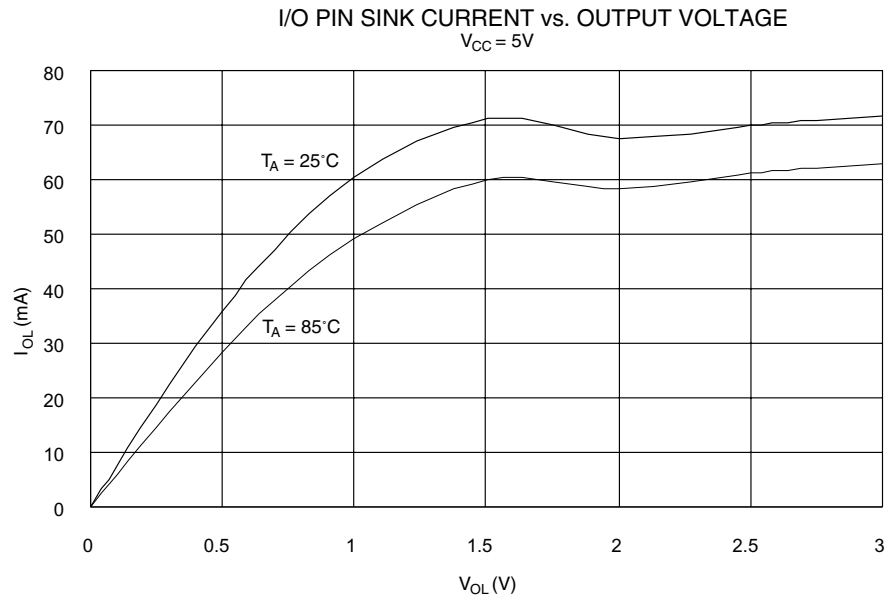

Figure 52. I/O Pin Source Current vs. Output Voltage

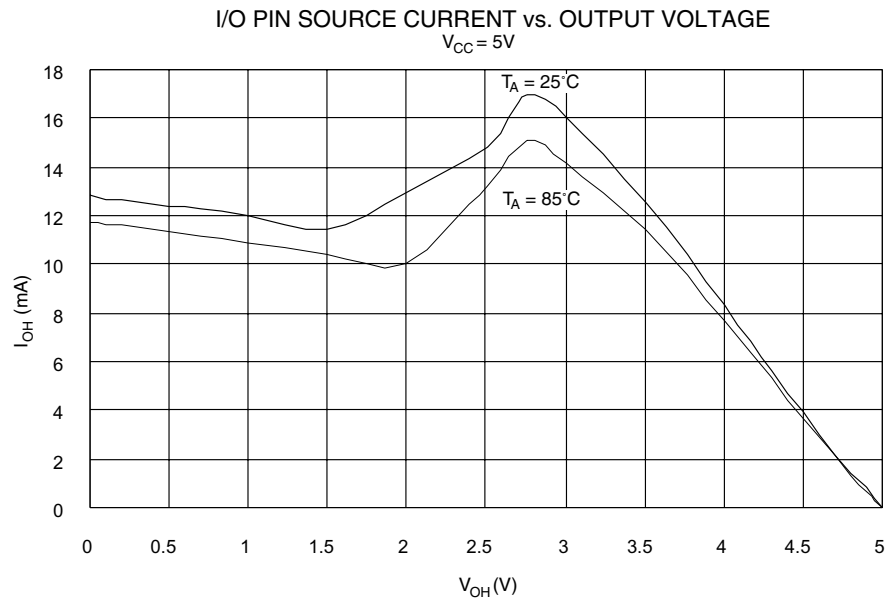

Figure 53. I/O Pin Sink Current vs. Output Voltage

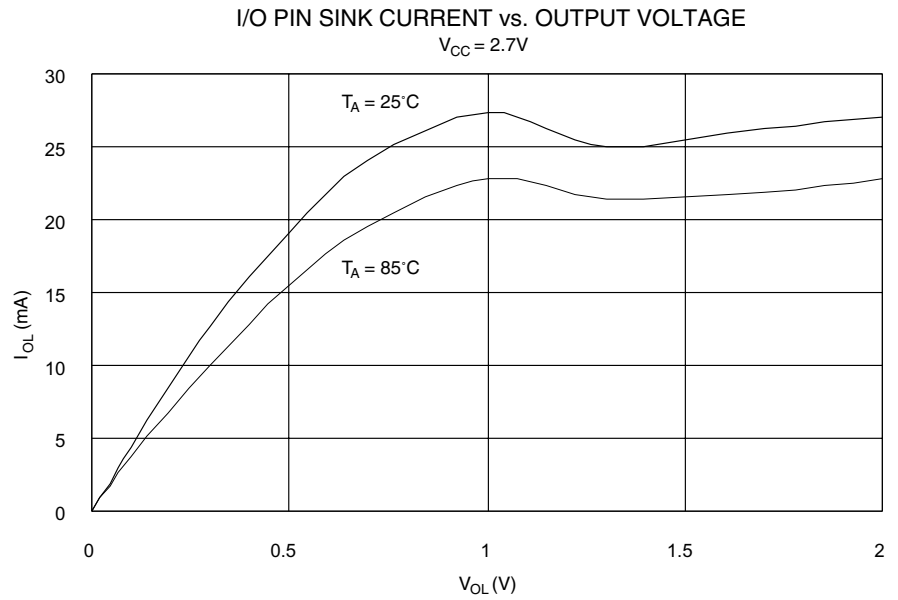

Figure 54. I/O Pin Source Current vs. Output Voltage

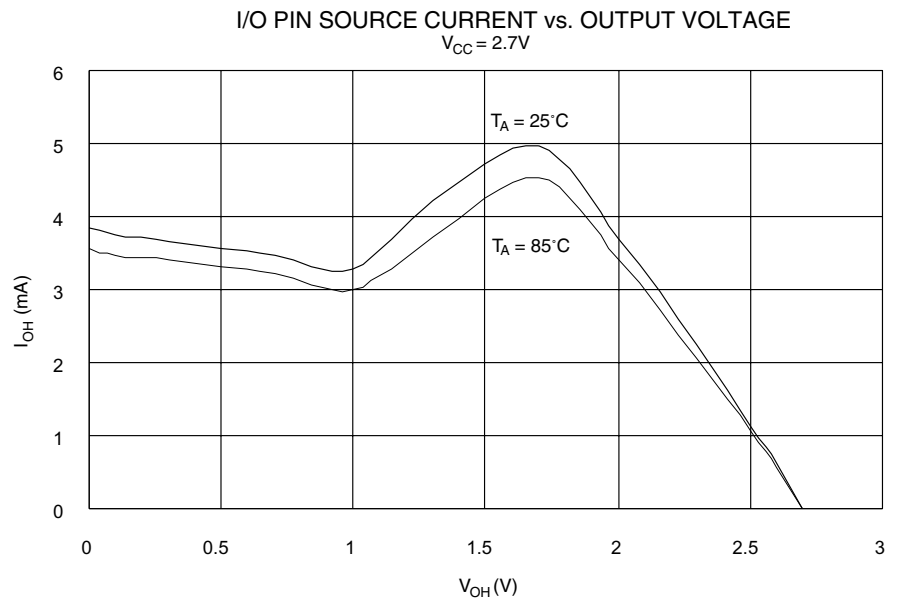

Figure 55. I/O Pin Input Threshold Voltage vs. V_{CC}

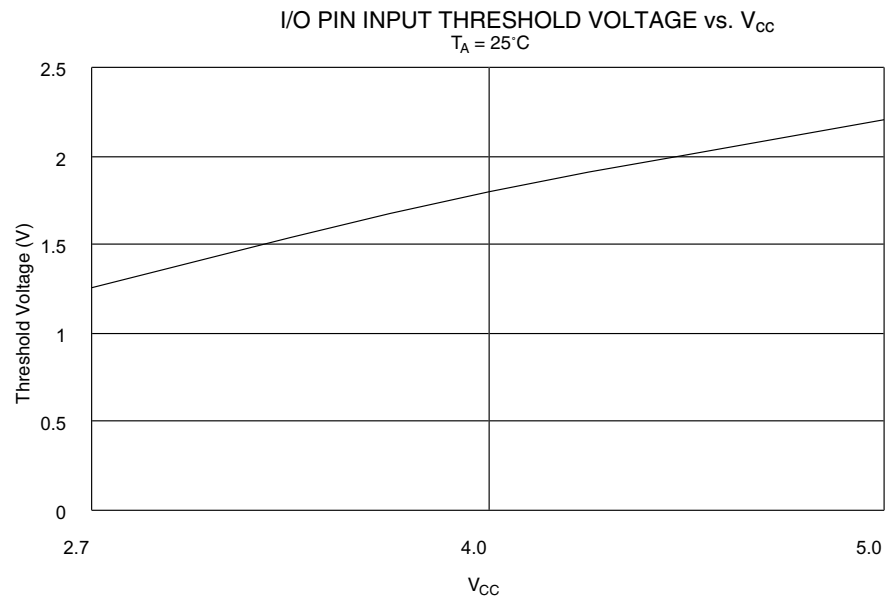
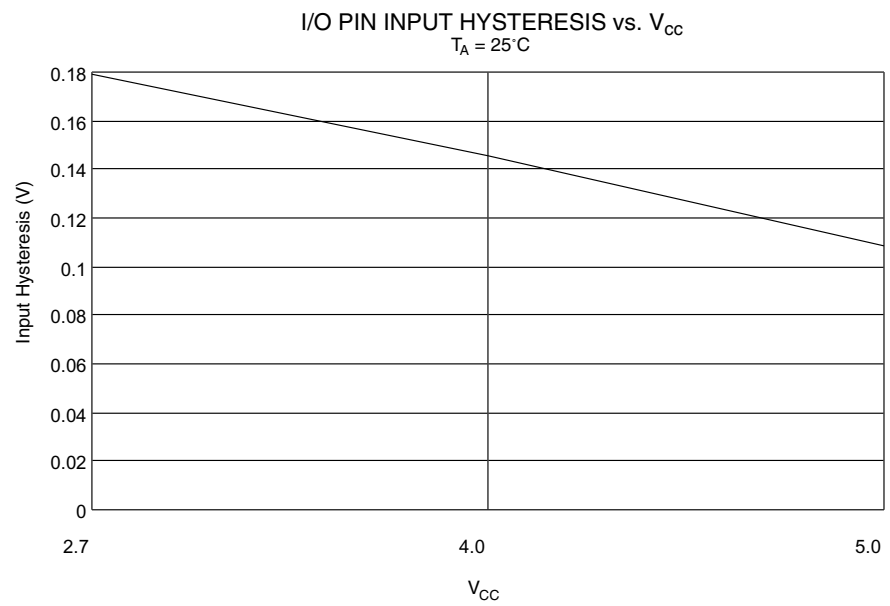

Figure 56. I/O Pin Input Hysteresis vs. V_{CC}



ATtiny12 Typical Characteristics

The following charts show typical behavior. These data are characterized, but not tested. All current consumption measurements are performed with all I/O pins configured as inputs and with internal pull-ups enabled. A sine wave generator with rail-to-rail output is used as clock source.

The power consumption in Power-down Mode is independent of clock selection.

The current consumption is a function of several factors such as: operating voltage, operating frequency, loading of I/O pins, switching rate of I/O pins, code executed and ambient temperature. The dominating factors are operating voltage and frequency.

The current drawn from capacitive loaded pins may be estimated (for one pin) as $C_L * V_{CC} * f$ where C_L = load capacitance, V_{CC} = operating voltage and f = average switching frequency of I/O pin.

The parts are characterized at frequencies higher than test limits. Parts are not guaranteed to function properly at frequencies higher than the ordering code indicates.

The difference between current consumption in Power-down Mode with Watchdog Timer enabled and Power-down Mode with Watchdog Timer disabled represents the differential current drawn by the Watchdog timer.

Figure 57. Active Supply Current vs. V_{CC} , Device Clocked by Internal Oscillator

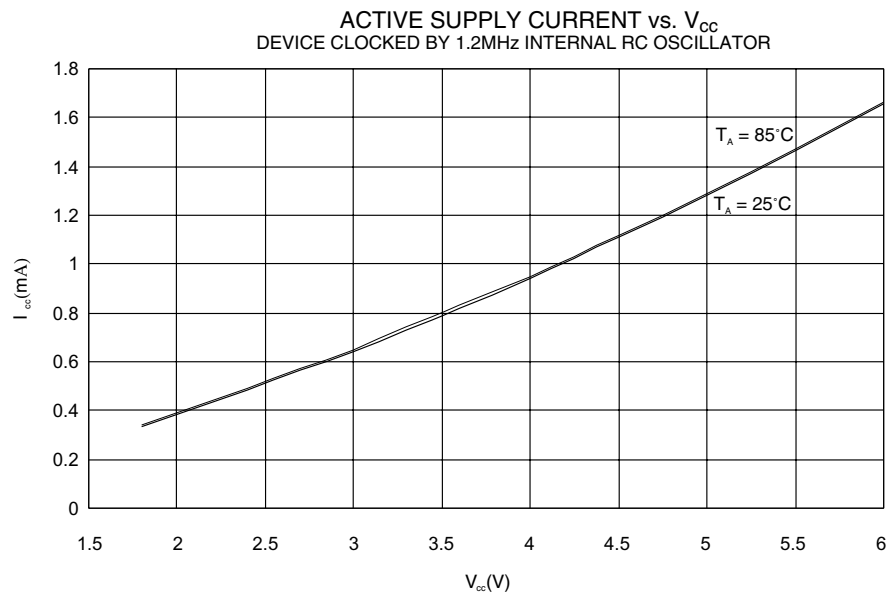

Figure 58. Active Supply Current vs. V_{CC} , Device Clocked by External 32kHz Crystal

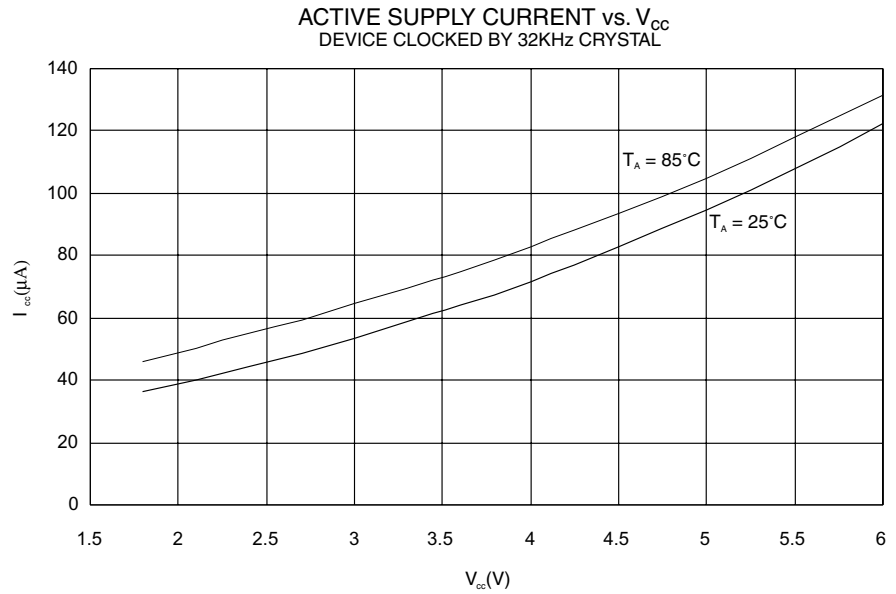

Figure 59. Idle Supply Current vs. V_{CC} , Device Clocked by Internal Oscillator

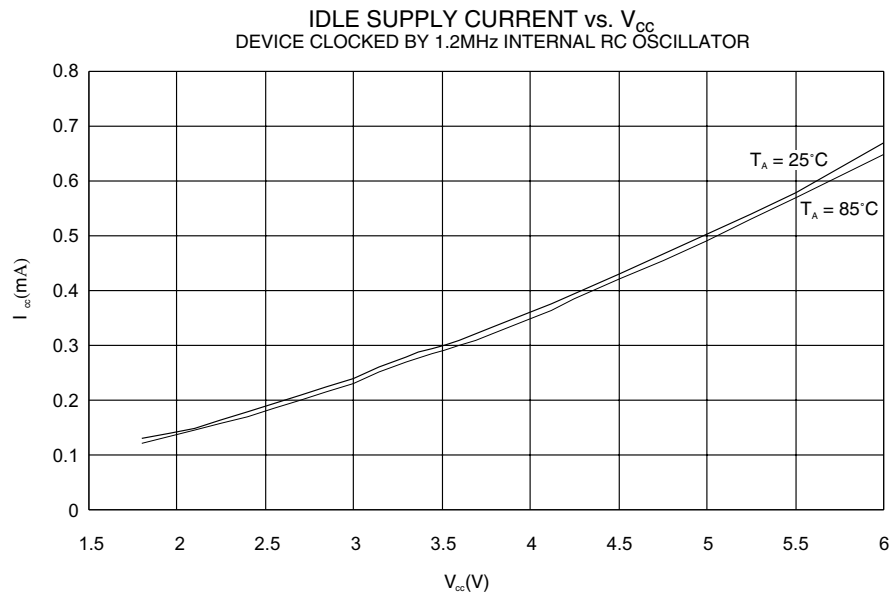
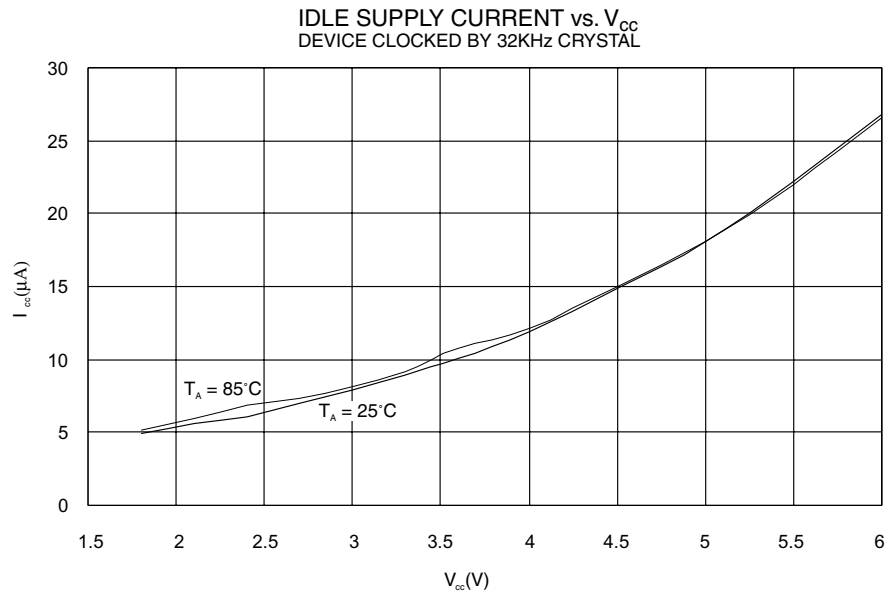

Figure 60. Idle Supply Current vs. V_{CC} , Device Clocked by External 32kHz Crystal



Analog Comparator offset voltage is measured as absolute offset.

Figure 61. Analog Comparator Offset Voltage vs. Common Mode Voltage

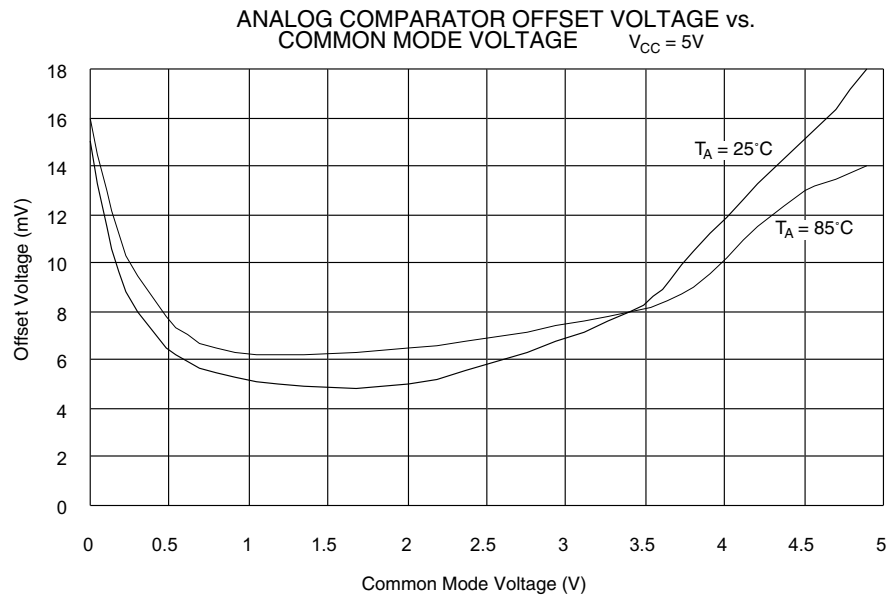

Figure 62. Analog Comparator Offset Voltage vs. Common Mode Voltage

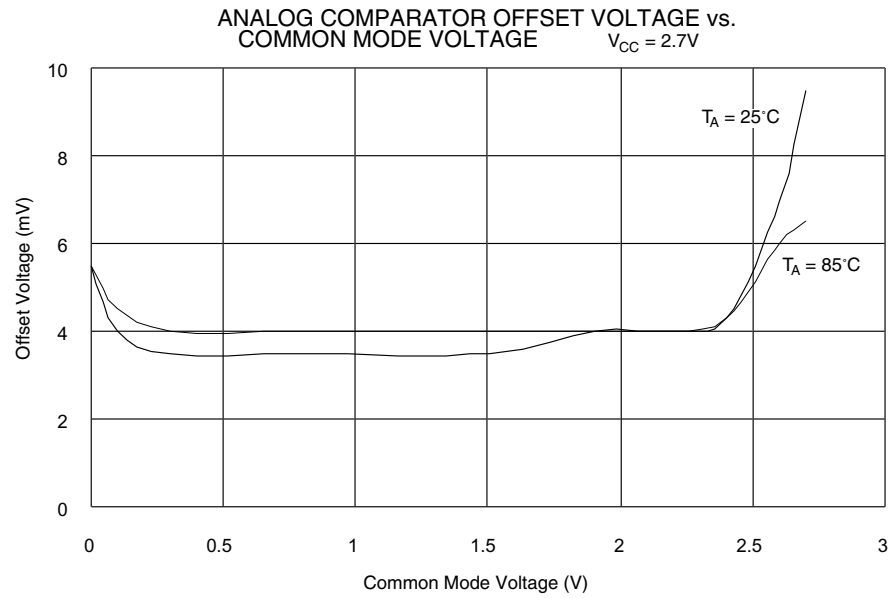

Figure 63. Analog Comparator Input Leakage Current

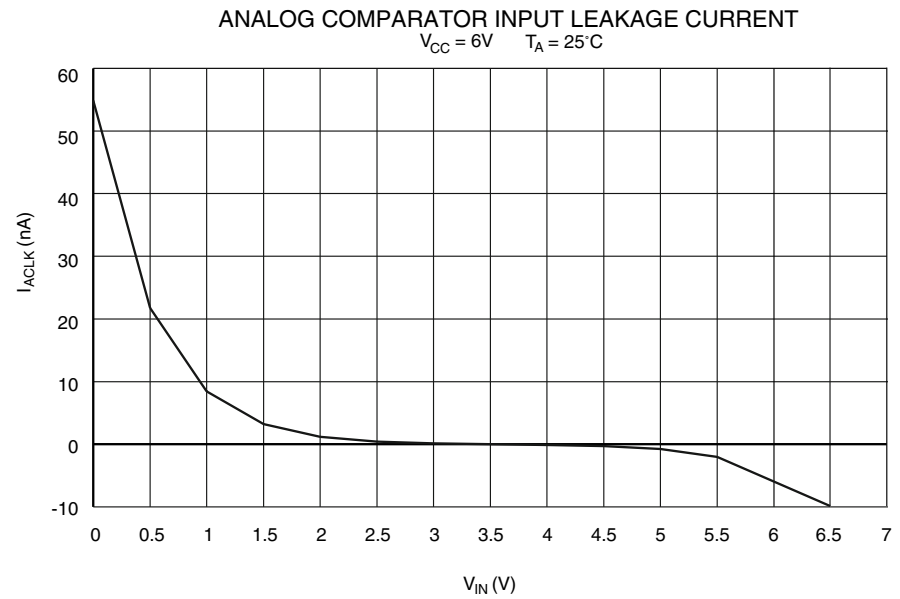

Figure 64. Calibrated RC Oscillator Frequency vs. V_{CC}

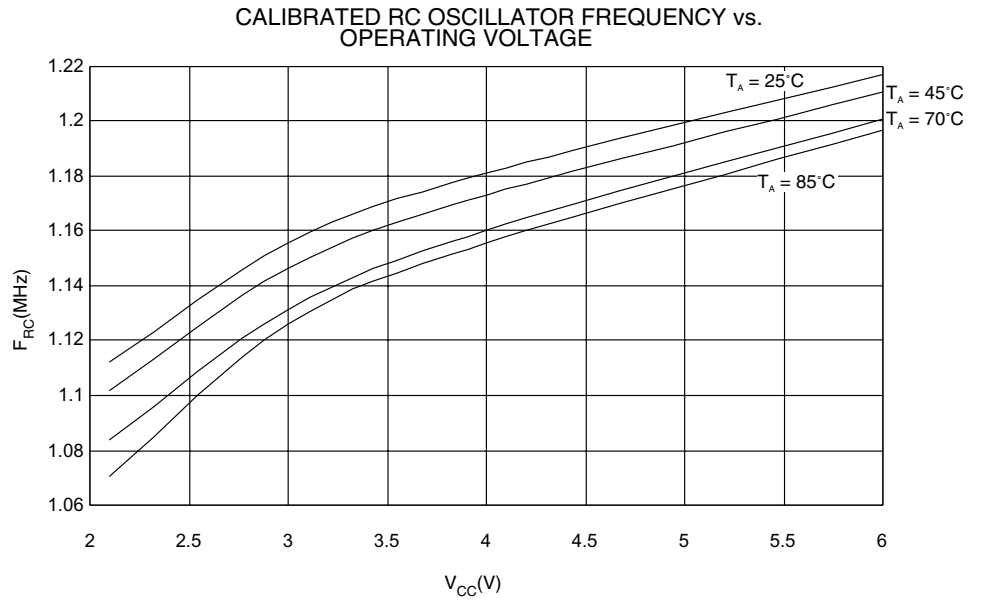
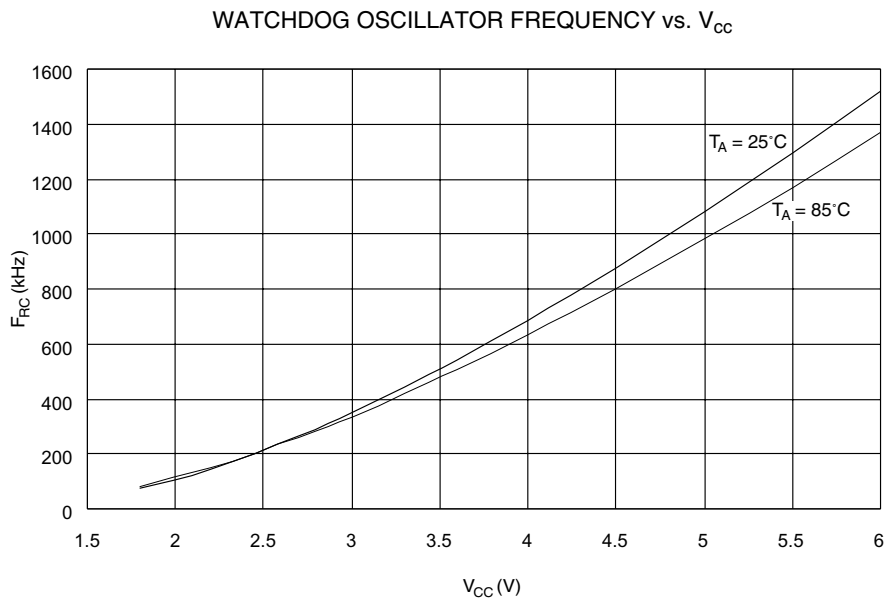

Figure 65. Watchdog Oscillator Frequency vs. V_{CC}



Sink and source capabilities of I/O ports are measured on one pin at a time.

Figure 66. Pull-up Resistor Current vs. Input Voltage ($V_{CC} = 5V$)

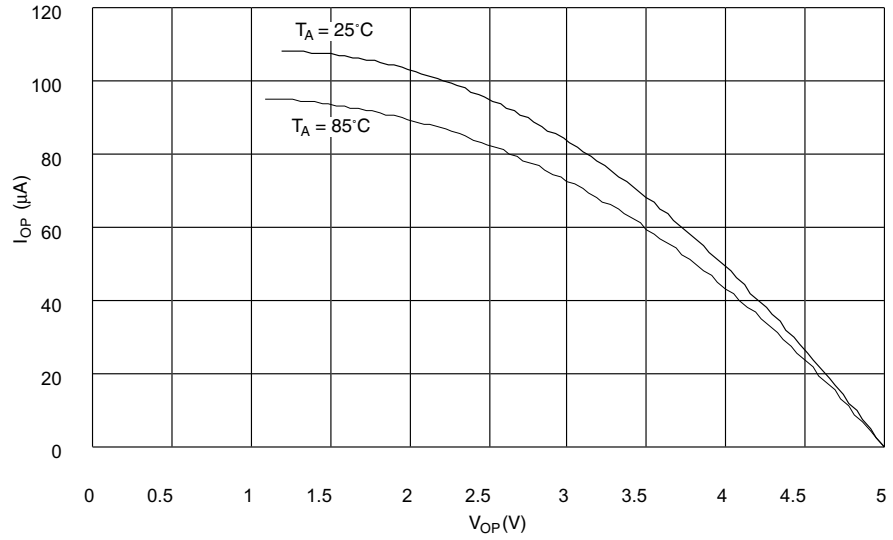

Figure 67. Pull-up Resistor Current vs. Input Voltage ($V_{CC} = 2.7V$)

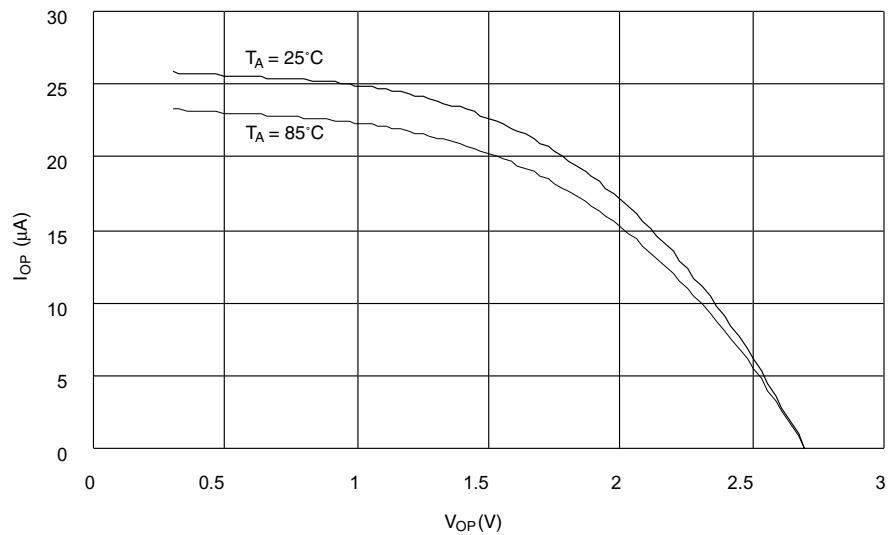

Figure 68. I/O Pin Sink Current vs. Output Voltage ($V_{CC} = 5V$)

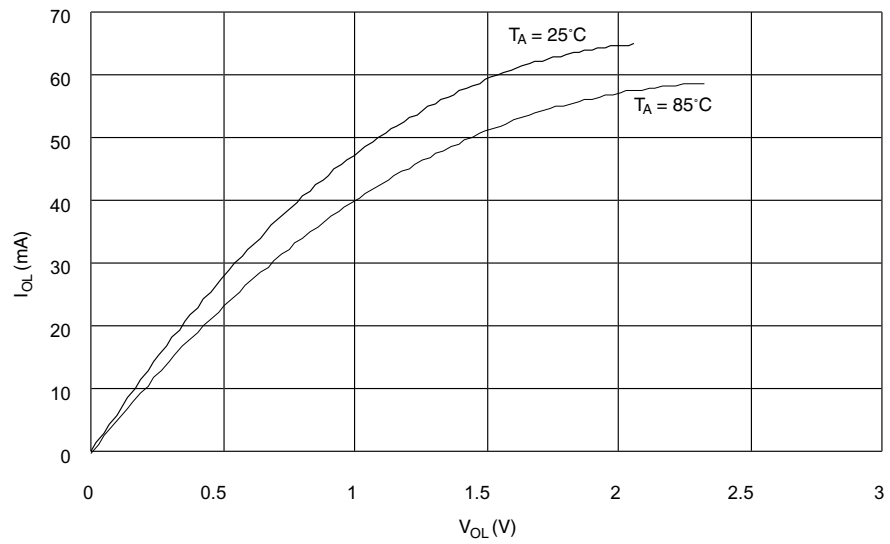

Figure 69. I/O Pin Source Current vs. Output Voltage ($V_{CC} = 5V$)

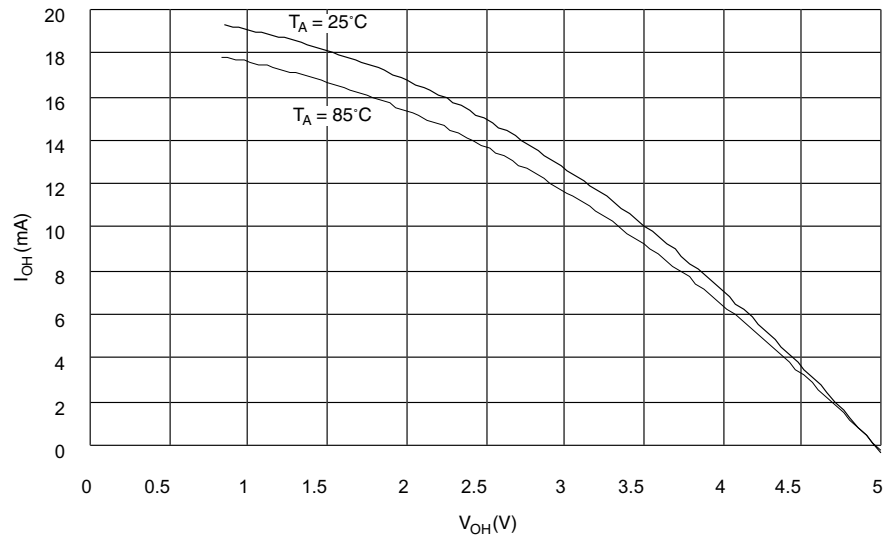

Figure 70. I/O Pin Sink Current vs. Output Voltage ($V_{CC} = 2.7V$)

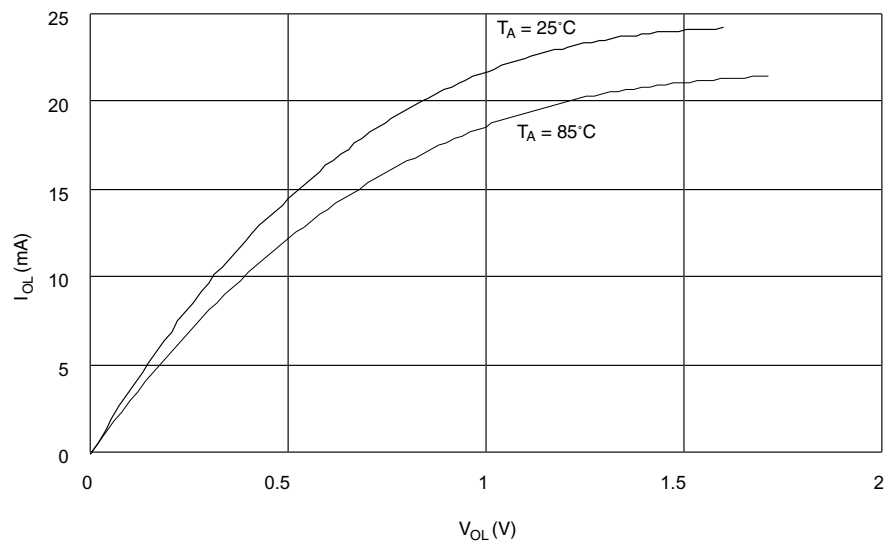

Figure 71. I/O Pin Source Current vs. Output Voltage ($V_{CC} = 2.7V$)

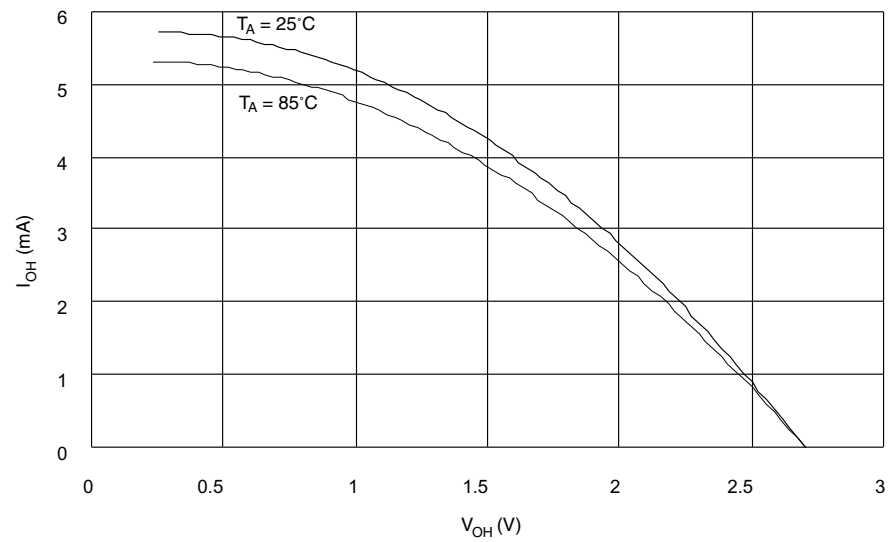

Figure 72. I/O Pin Input Threshold Voltage vs. V_{CC} ($T_A = 25^\circ\text{C}$)

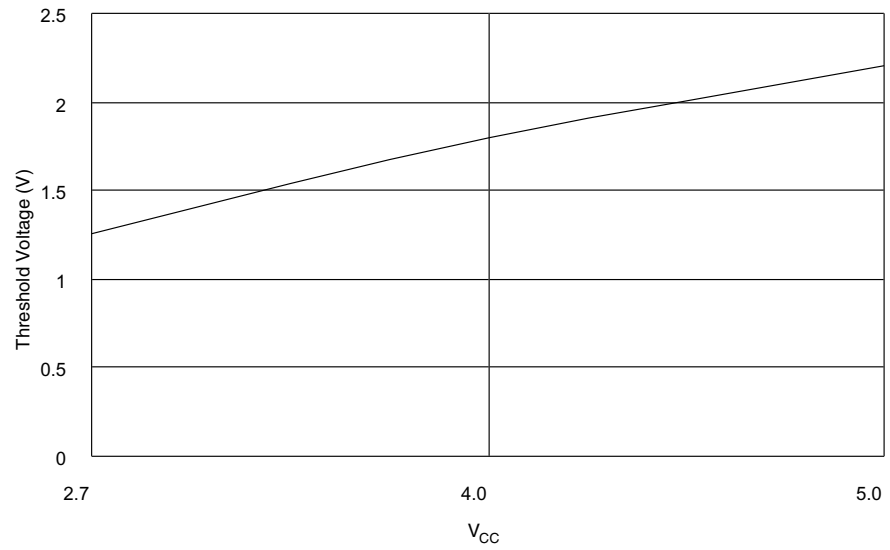
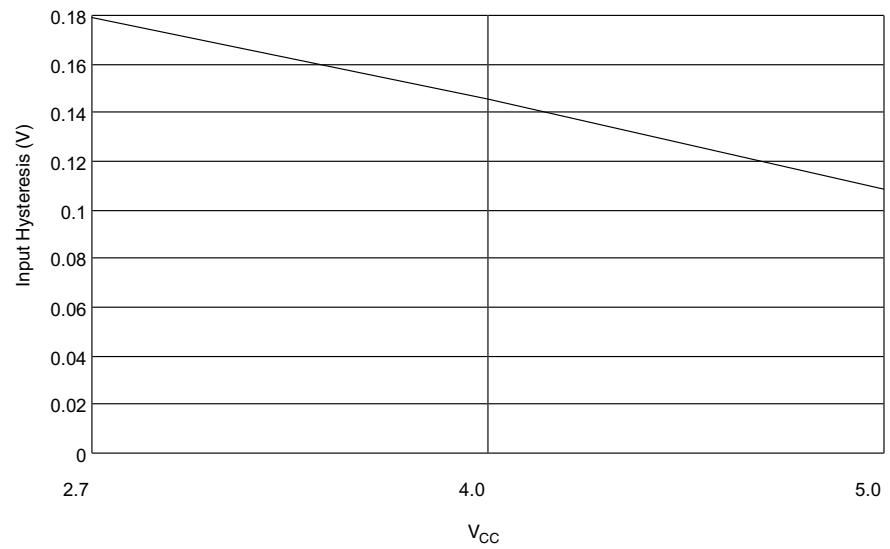

Figure 73. I/O Pin Input Hysteresis vs. V_{CC} ($T_A = 25^\circ\text{C}$)



Register Summary ATtiny11

Address	Name	Bit 7	Bit 6	Bit 5	Bit 4	Bit 3	Bit 2	Bit 1	Bit 0	Page
\$3F	SREG	I	T	H	S	V	N	Z	C	page 14
\$3E	Reserved									
\$3D	Reserved									
\$3C	Reserved									
\$3B	GIMSK	-	INT0	PCIE	-	-	-	-	-	page 25
\$3A	GIFR	-	INTF0	PCIF	-	-	-	-	-	page 26
\$39	TIMSK	-	-	-	-	-	-	TOIE0	-	page 26
\$38	TIFR	-	-	-	-	-	-	TOV0	-	page 27
\$37	Reserved									
\$36	Reserved									
\$35	MCUCR	-	-	SE	SM	-	-	ISC01	ISC00	page 28
\$34	MCUSR	-	-	-	-	-	-	EXTRF	PORF	page 23
\$33	TCCR0	-	-	-	-	-	CS02	CS01	CS00	page 32
\$32	TCNT0	Timer/Counter0 (8 Bit)								page 33
\$31	Reserved									
\$30	Reserved									
...	Reserved									
\$22	Reserved									
\$21	WDTCR	-	-	-	WDTOE	WDE	WDP2	WDP1	WDP0	page 34
\$20	Reserved									
\$1F	Reserved									
\$1E	Reserved									
\$1D	Reserved									
\$1C	Reserved									
\$1B	Reserved									
\$1A	Reserved									
\$19	Reserved									
\$18	PORTB	-	-	-	PORTB4	PORTB3	PORTB2	PORTB1	PORTB0	page 42
\$17	DDRB	-	-	-	DDB4	DDB3	DDB2	DDB1	DDB0	page 42
\$16	PINB	-	-	PINB5	PINB4	PINB3	PINB2	PINB1	PINB0	page 42
\$15	Reserved									
...	Reserved									
\$0A	Reserved									
\$09	Reserved									
\$08	ACSR	ACD	-	ACO	ACI	ACIE	-	ACIS1	ACIS0	page 39
...	Reserved									
\$00	Reserved									

- Notes:
1. For compatibility with future devices, reserved bits should be written to zero if accessed. Reserved I/O memory addresses should never be written.
 2. Some of the status flags are cleared by writing a logical one to them. Note that the CBI and SBI instructions will operate on all bits in the I/O register, writing a one back into any flag read as set, thus clearing the flag. The CBI and SBI instructions work with registers \$00 to \$1F only.



Register Summary ATtiny12

Address	Name	Bit 7	Bit 6	Bit 5	Bit 4	Bit 3	Bit 2	Bit 1	Bit 0	Page
\$3F	SREG	I	T	H	S	V	N	Z	C	page 14
\$3E	Reserved									
\$3D	Reserved									
\$3C	Reserved									
\$3B	GIMSK	-	INT0	PCIE	-	-	-	-	-	page 25
\$3A	GIFR	-	INTF0	PCIF	-	-	-	-	-	page 26
\$39	TIMSK	-	-	-	-	-	-	TOIE0	-	page 26
\$38	TIFR	-	-	-	-	-	-	TOV0	-	page 27
\$37	Reserved									
\$36	Reserved									
\$35	MCUCR	-	PUD	SE	SM	-	-	ISC01	ISC00	page 28
\$34	MCUSR	-	-	-	-	WDRF	BORF	EXTRF	PORF	page 24
\$33	TCCR0	-	-	-	-	-	CS02	CS01	CS00	page 32
\$32	TCNT0	Timer/Counter0 (8 Bit)								page 33
\$31	OSCCAL	Oscillator Calibration Register								page 30
\$30	Reserved									
...	Reserved									
\$22	Reserved									
\$21	WDTCR	-	-	-	WDTOE	WDE	WDP2	WDP1	WDP0	page 34
\$20	Reserved									
\$1F	Reserved									
\$1E	EEAR	-	-	EEPROM Address Register						page 36
\$1D	EEDR	EEPROM Data Register								page 36
\$1C	EECR	-	-	-	-	EERIE	EEMWE	EEWE	EERE	page 36
\$1B	Reserved									
\$1A	Reserved									
\$19	Reserved									
\$18	PORTB	-	-	-	PORTB4	PORTB3	PORTB2	PORTB1	PORTB0	page 42
\$17	DDRB	-	-	DDB5	DDB4	DDB3	DDB2	DDB1	DDB0	page 42
\$16	PINB	-	-	PINB5	PINB4	PINB3	PINB2	PINB1	PINB0	page 42
\$15	Reserved									
...	Reserved									
\$0A	Reserved									
\$09	Reserved									
\$08	ACSR	ACD	AINBG	ACO	ACI	ACIE	-	ACIS1	ACIS0	page 39
...	Reserved									
\$00	Reserved									

- Note:
1. For compatibility with future devices, reserved bits should be written to zero if accessed. Reserved I/O memory addresses should never be written.
 2. Some of the status flags are cleared by writing a logical one to them. Note that the CBI and SBI instructions will operate on all bits in the I/O register, writing a one back into any flag read as set, thus clearing the flag. The CBI and SBI instructions work with registers \$00 to \$1F only.

Instruction Set Summary

Mnemonics	Operands	Description	Operation	Flags	#Clocks
ARITHMETIC AND LOGIC INSTRUCTIONS					
ADD	Rd, Rr	Add two Registers	$Rd \leftarrow Rd + Rr$	Z,C,N,V,H	1
ADC	Rd, Rr	Add with Carry two Registers	$Rd \leftarrow Rd + Rr + C$	Z,C,N,V,H	1
SUB	Rd, Rr	Subtract two Registers	$Rd \leftarrow Rd - Rr$	Z,C,N,V,H	1
SUBI	Rd, K	Subtract Constant from Register	$Rd \leftarrow Rd - K$	Z,C,N,V,H	1
SBC	Rd, Rr	Subtract with Carry two Registers	$Rd \leftarrow Rd - Rr - C$	Z,C,N,V,H	1
SBCI	Rd, K	Subtract with Carry Constant from Reg.	$Rd \leftarrow Rd - K - C$	Z,C,N,V,H	1
AND	Rd, Rr	Logical AND Registers	$Rd \leftarrow Rd \cdot Rr$	Z,N,V	1
ANDI	Rd, K	Logical AND Register and Constant	$Rd \leftarrow Rd \cdot K$	Z,N,V	1
OR	Rd, Rr	Logical OR Registers	$Rd \leftarrow Rd \vee Rr$	Z,N,V	1
ORI	Rd, K	Logical OR Register and Constant	$Rd \leftarrow Rd \vee K$	Z,N,V	1
EOR	Rd, Rr	Exclusive OR Registers	$Rd \leftarrow Rd \oplus Rr$	Z,N,V	1
COM	Rd	One's Complement	$Rd \leftarrow \text{NOT } Rd$	Z,C,N,V	1
NEG	Rd	Two's Complement	$Rd \leftarrow \text{NOT } Rd + 1$	Z,C,N,V,H	1
SBR	Rd,K	Set Bit(s) in Register	$Rd \leftarrow Rd \vee K$	Z,N,V	1
CBR	Rd,K	Clear Bit(s) in Register	$Rd \leftarrow Rd \cdot (\text{NOT } K)$	Z,N,V	1
INC	Rd	Increment	$Rd \leftarrow Rd + 1$	Z,N,V	1
DEC	Rd	Decrement	$Rd \leftarrow Rd - 1$	Z,N,V	1
TST	Rd	Test for Zero or Minus	$Rd \leftarrow Rd \cdot Rd$	Z,N,V	1
CLR	Rd	Clear Register	$Rd \leftarrow \text{NOT } Rd$	Z,N,V	1
SER	Rd	Set Register	$Rd \leftarrow \text{NOT } Rd$	None	1
BRANCH INSTRUCTIONS					
RJMP	k	Relative Jump	$PC \leftarrow PC + k + 1$	None	2
RCALL	k	Relative Subroutine Call	$PC \leftarrow PC + k + 1$	None	3
RET		Subroutine Return	$PC \leftarrow \text{STACK}$	None	4
RETI		Interrupt Return	$PC \leftarrow \text{STACK}$	I	4
CPSE	Rd,Rr	Compare, Skip if Equal	if (Rd = Rr) $PC \leftarrow PC + 2$ or 3	None	1/2
CP	Rd,Rr	Compare	$Rd - Rr$	Z, N,V,C,H	1
CPC	Rd,Rr	Compare with Carry	$Rd - Rr - C$	Z, N,V,C,H	1
CPI	Rd,K	Compare Register with Immediate	$Rd - K$	Z, N,V,C,H	1
SBRC	Rr, b	Skip if Bit in Register Cleared	if (Rr(b)=0) $PC \leftarrow PC + 2$ or 3	None	1/2
SBRS	Rr, b	Skip if Bit in Register is Set	if (Rr(b)=1) $PC \leftarrow PC + 2$ or 3	None	1/2
SBIC	P, b	Skip if Bit in I/O Register Cleared	if (P(b)=0) $PC \leftarrow PC + 2$ or 3	None	1/2
SBIS	P, b	Skip if Bit in I/O Register is Set	if (P(b)=1) $PC \leftarrow PC + 2$ or 3	None	1/2
BRBS	s, k	Branch if Status Flag Set	if (SREG(s) = 1) then $PC \leftarrow PC + k + 1$	None	1/2
BRBC	s, k	Branch if Status Flag Cleared	if (SREG(s) = 0) then $PC \leftarrow PC + k + 1$	None	1/2
BREQ	k	Branch if Equal	if (Z = 1) then $PC \leftarrow PC + k + 1$	None	1/2
BRNE	k	Branch if Not Equal	if (Z = 0) then $PC \leftarrow PC + k + 1$	None	1/2
BRCS	k	Branch if Carry Set	if (C = 1) then $PC \leftarrow PC + k + 1$	None	1/2
BRCC	k	Branch if Carry Cleared	if (C = 0) then $PC \leftarrow PC + k + 1$	None	1/2
BRSH	k	Branch if Same or Higher	if (C = 0) then $PC \leftarrow PC + k + 1$	None	1/2
BRLO	k	Branch if Lower	if (C = 1) then $PC \leftarrow PC + k + 1$	None	1/2
BRMI	k	Branch if Minus	if (N = 1) then $PC \leftarrow PC + k + 1$	None	1/2
BRPL	k	Branch if Plus	if (N = 0) then $PC \leftarrow PC + k + 1$	None	1/2
BRGE	k	Branch if Greater or Equal, Signed	if (N \oplus V = 0) then $PC \leftarrow PC + k + 1$	None	1/2
BRLT	k	Branch if Less Than Zero, Signed	if (N \oplus V = 1) then $PC \leftarrow PC + k + 1$	None	1/2
BRHS	k	Branch if Half Carry Flag Set	if (H = 1) then $PC \leftarrow PC + k + 1$	None	1/2
BRHC	k	Branch if Half Carry Flag Cleared	if (H = 0) then $PC \leftarrow PC + k + 1$	None	1/2
BRTS	k	Branch if T Flag Set	if (T = 1) then $PC \leftarrow PC + k + 1$	None	1/2
BRTC	k	Branch if T Flag Cleared	if (T = 0) then $PC \leftarrow PC + k + 1$	None	1/2
BRVS	k	Branch if Overflow Flag is Set	if (V = 1) then $PC \leftarrow PC + k + 1$	None	1/2
BRVC	k	Branch if Overflow Flag is Cleared	if (V = 0) then $PC \leftarrow PC + k + 1$	None	1/2
BRIE	k	Branch if Interrupt Enabled	if (I = 1) then $PC \leftarrow PC + k + 1$	None	1/2
BRID	k	Branch if Interrupt Disabled	if (I = 0) then $PC \leftarrow PC + k + 1$	None	1/2



Instruction Set Summary (Continued)

Mnemonics	Operands	Description	Operation	Flags	#Clocks
DATA TRANSFER INSTRUCTIONS					
LD	Rd,Z	Load Register Indirect	$Rd \leftarrow (Z)$	None	2
ST	Z,Rr	Store Register Indirect	$(Z) \leftarrow Rr$	None	2
MOV	Rd, Rr	Move Between Registers	$Rd \leftarrow Rr$	None	1
LDI	Rd, K	Load Immediate	$Rd \leftarrow K$	None	1
IN	Rd, P	In Port	$Rd \leftarrow P$	None	1
OUT	P, Rr	Out Port	$P \leftarrow Rr$	None	1
LPM		Load Program Memory	$R0 \leftarrow (Z)$	None	3
BIT AND BIT-TEST INSTRUCTIONS					
SBI	P,b	Set Bit in I/O Register	$I/O(P,b) \leftarrow 1$	None	2
CBI	P,b	Clear Bit in I/O Register	$I/O(P,b) \leftarrow 0$	None	2
LSL	Rd	Logical Shift Left	$Rd(n+1) \leftarrow Rd(n), Rd(0) \leftarrow 0$	Z,C,N,V	1
LSR	Rd	Logical Shift Right	$Rd(n) \leftarrow Rd(n+1), Rd(7) \leftarrow 0$	Z,C,N,V	1
ROL	Rd	Rotate Left Through Carry	$Rd(0) \leftarrow C, Rd(n+1) \leftarrow Rd(n), C \leftarrow Rd(7)$	Z,C,N,V	1
ROR	Rd	Rotate Right Through Carry	$Rd(7) \leftarrow C, Rd(n) \leftarrow Rd(n+1), C \leftarrow Rd(0)$	Z,C,N,V	1
ASR	Rd	Arithmetic Shift Right	$Rd(n) \leftarrow Rd(n+1), n = 0..6$	Z,C,N,V	1
SWAP	Rd	Swap Nibbles	$Rd(3..0) \leftarrow Rd(7..4), Rd(7..4) \leftarrow Rd(3..0)$	None	1
BSET	s	Flag Set	$SREG(s) \leftarrow 1$	SREG(s)	1
BCLR	s	Flag Clear	$SREG(s) \leftarrow 0$	SREG(s)	1
BST	Rr, b	Bit Store from Register to T	$T \leftarrow Rr(b)$	T	1
BLD	Rd, b	Bit load from T to Register	$Rd(b) \leftarrow T$	None	1
SEC		Set Carry	$C \leftarrow 1$	C	1
CLC		Clear Carry	$C \leftarrow 0$	C	1
SEN		Set Negative Flag	$N \leftarrow 1$	N	1
CLN		Clear Negative Flag	$N \leftarrow 0$	N	1
SEZ		Set Zero Flag	$Z \leftarrow 1$	Z	1
CLZ		Clear Zero Flag	$Z \leftarrow 0$	Z	1
SEI		Global Interrupt Enable	$I \leftarrow 1$	I	1
CLI		Global Interrupt Disable	$I \leftarrow 0$	I	1
SES		Set Signed Test Flag	$S \leftarrow 1$	S	1
CLS		Clear Signed Test Flag	$S \leftarrow 0$	S	1
SEV		Set Twos Complement Overflow	$V \leftarrow 1$	V	1
CLV		Clear Twos Complement Overflow	$V \leftarrow 0$	V	1
SET		Set T in SREG	$T \leftarrow 1$	T	1
CLT		Clear T in SREG	$T \leftarrow 0$	T	1
SEH		Set Half Carry Flag in SREG	$H \leftarrow 1$	H	1
CLH		Clear Half Carry Flag in SREG	$H \leftarrow 0$	H	1
NOP		No Operation		None	1
SLEEP		Sleep	(see specific descr. for Sleep function)	None	1
WDR		Watch Dog Reset	(see specific descr. for WDR/timer)	None	1

Ordering Information

Power Supply	Speed (MHz)	Ordering Code	Package	Operation Range
2.7 - 5.5V	2	ATtiny11L-2PC ATtiny11L-2SC	8P3 8S2	Commercial (0°C to 70°C)
		ATtiny11L-2PI ATtiny11L-2SI	8P3 8S2	Industrial (-40°C to 85°C)
4.0 - 5.5V	6	ATtiny11-6PC ATtiny11-6SC	8P3 8S2	Commercial (0°C to 70°C)
		ATtiny11-6PI ATtiny11-6SI	8P3 8S2	Industrial (-40°C to 85°C)
1.8 - 5.5V	1.2	ATtiny12V-1PC ATtiny12V-1SC	8P3 8S2	Commercial (0°C to 70°C)
		ATtiny12V-1PI ATtiny12V-1SI	8P3 8S2	Industrial (-40°C to 85°C)
2.7 - 5.5V	4	ATtiny12L-4PC ATtiny12L-4SC	8P3 8S2	Commercial (0°C to 70°C)
		ATtiny12L-4PI ATtiny12L-4SI	8P3 8S2	Industrial (-40°C to 85°C)
4.0 - 5.5V	8	ATtiny12-8PC ATtiny12-8SC	8P3 8S2	Commercial (0°C to 70°C)
		ATtiny12-8PI ATtiny12-8SI	8P3 8S2	Industrial (-40°C to 85°C)

Note: The speed grade refers to maximum clock rate when using an external crystal or external clock drive. The internal RC oscillator has the same nominal clock frequency for all speed grades.

Package Type	
8P3	8-lead, 0.300" Wide, Plastic Dual Inline Package (PDIP)
8S2	8-lead, 0.200" Wide, Plastic Gull-Wing Small Outline (EIAJ SOIC)

Packaging Information

8P3

8P3, 8-lead, Plastic Dual Inline
 Package (PDIP), 0.300" Wide.
 Dimensions in Millimeters and (Inches)*
 JEDEC STANDARD MS-001 BA

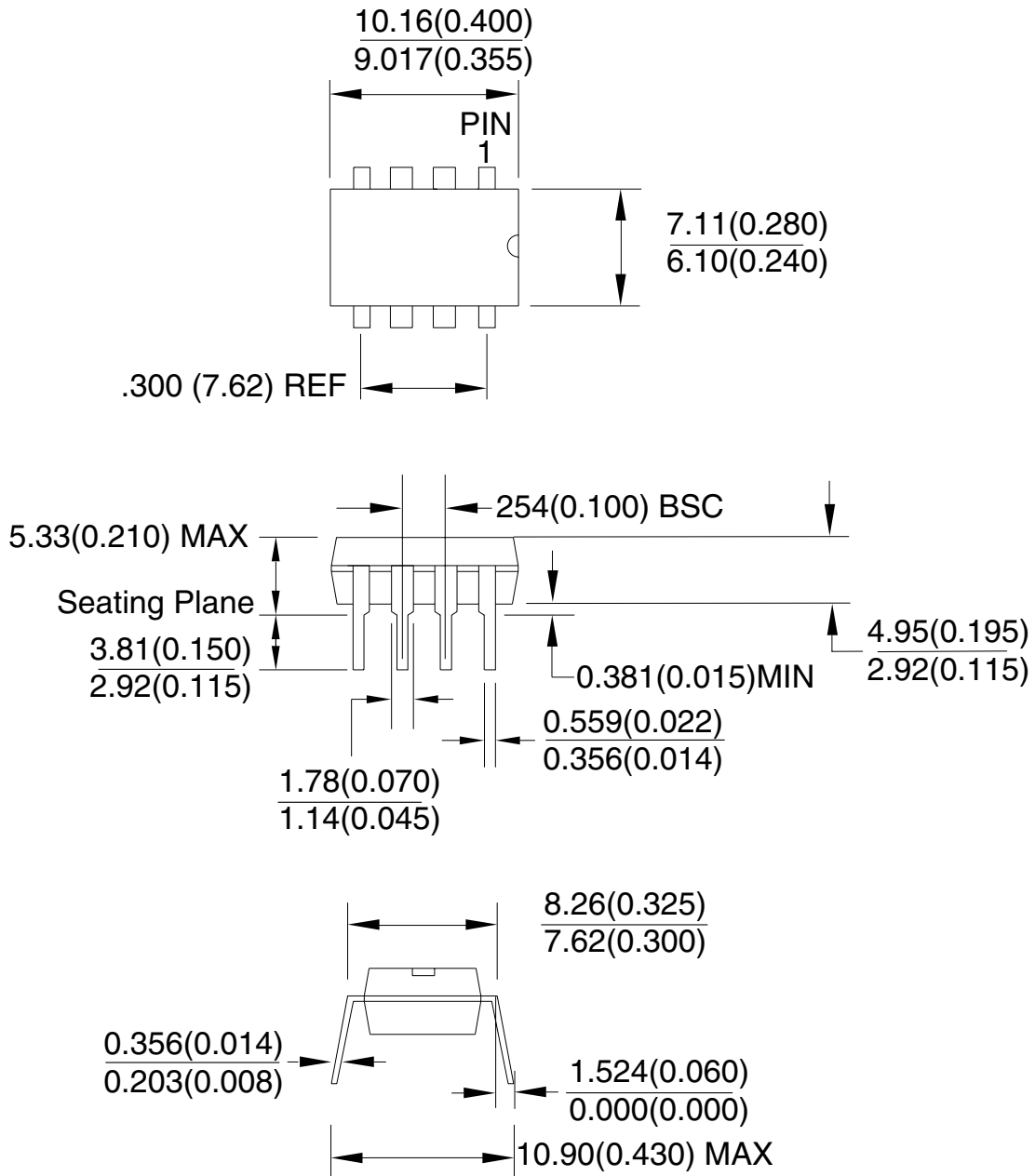

*Controlling dimension: Inches

REV. A 04/11/2001



Atmel Headquarters

Corporate Headquarters
2325 Orchard Parkway
San Jose, CA 95131
TEL (408) 441-0311
FAX (408) 487-2600

Europe

Atmel SarL
Route des Arsenaux 41
Casa Postale 80
CH-1705 Fribourg
Switzerland
TEL (41) 26-426-5555
FAX (41) 26-426-5500

Asia

Atmel Asia, Ltd.
Room 1219
Chinachem Golden Plaza
77 Mody Road Tsimhatsui
East Kowloon
Hong Kong
TEL (852) 2721-9778
FAX (852) 2722-1369

Japan

Atmel Japan K.K.
9F, Tonetsu Shinkawa Bldg.
1-24-8 Shinkawa
Chuo-ku, Tokyo 104-0033
Japan
TEL (81) 3-3523-3551
FAX (81) 3-3523-7581

Atmel Product Operations

Atmel Colorado Springs

1150 E. Cheyenne Mtn. Blvd.
Colorado Springs, CO 80906
TEL (719) 576-3300
FAX (719) 540-1759

Atmel Grenoble

Avenue de Rochepleine
BP 123
38521 Saint-Egreve Cedex, France
TEL (33) 4-7658-3000
FAX (33) 4-7658-3480

Atmel Heilbronn

Theresienstrasse 2
POB 3535
D-74025 Heilbronn, Germany
TEL (49) 71 31 67 25 94
FAX (49) 71 31 67 24 23

Atmel Nantes

La Chantrerie
BP 70602
44306 Nantes Cedex 3, France
TEL (33) 0 2 40 18 18 18
FAX (33) 0 2 40 18 19 60

Atmel Rousset

Zone Industrielle
13106 Rousset Cedex, France
TEL (33) 4-4253-6000
FAX (33) 4-4253-6001

Atmel Smart Card ICs

Scottish Enterprise Technology Park
East Kilbride, Scotland G75 0QR
TEL (44) 1355-357-000
FAX (44) 1355-242-743

e-mail

literature@atmel.com

Web Site

<http://www.atmel.com>

BBS

1-(408) 436-4309

© Atmel Corporation 2001.

Atmel Corporation makes no warranty for the use of its products, other than those expressly contained in the Company's standard warranty which is detailed in Atmel's Terms and Conditions located on the Company's web site. The Company assumes no responsibility for any errors which may appear in this document, reserves the right to change devices or specifications detailed herein at any time without notice, and does not make any commitment to update the information contained herein. No licenses to patents or other intellectual property of Atmel are granted by the Company in connection with the sale of Atmel products, expressly or by implication. Atmel's products are not authorized for use as critical components in life support devices or systems.

ATMEL® and AVR® are the registered trademarks of Atmel.

Other terms and product names may be the trademarks of others.



Printed on recycled paper.