



LM158W-LM258W-LM358W

Low power dual operational amplifiers

Features

- Internally frequency compensated
- Large DC voltage gain: 100 dB
- Wide bandwidth (unity gain): 1.1 MHz (temperature compensated)
- Very low supply current per operator essentially independent of supply voltage
- Low input bias current: 20 nA (temperature compensated)
- Low input offset voltage: 2 mV
- Low input offset current: 2 nA
- Input common-mode voltage range includes ground
- Differential input voltage range equal to the power supply voltage
- Large output voltage swing 0 V to ($V_{CC} - 1.5$ V)
- ESD internal protection: 2 kV

Description

These circuits consist of two independent, high-gain, internally frequency-compensated which were designed specifically to operate from a single power supply over a wide range of voltages. The low power supply drain is independent of the magnitude of the power supply voltage.

Application areas include transducer amplifiers, DC gain blocks and all the conventional op-amp circuits which now can be more easily implemented in single power supply systems. For example, these circuits can be directly supplied with the standard +5 V which is used in logic systems and will easily provide the required interface electronics without requiring any additional power supply.

In the linear mode the input common-mode voltage range includes ground and the output

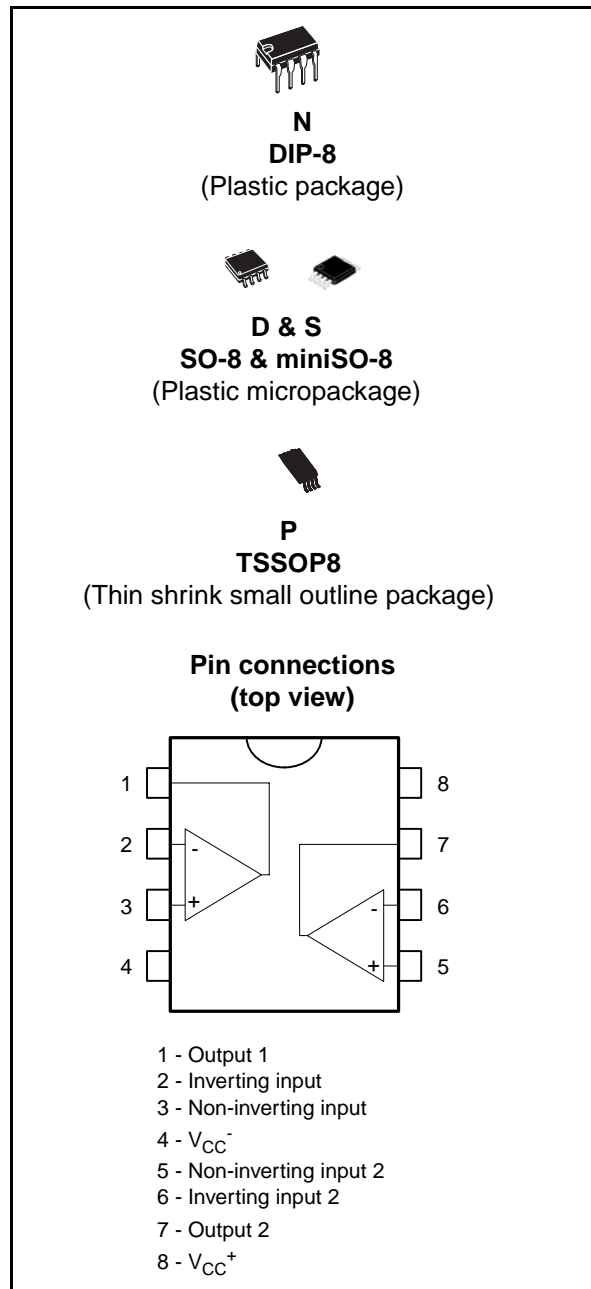

voltage can also swing to ground, even though operated from only a single power supply voltage.

Contents

1	Schematic diagram	3
2	Absolute maximum ratings and operating conditions	4
3	Electrical characteristics	6
4	Typical applications	11
5	Package mechanical data	13
5.1	DIP8 package	14
5.2	SO-8 package	15
5.3	MiniSO-8 package	16
5.4	TSSOP8 package	17
6	Ordering information	18
7	Revision history	19

1 Schematic diagram

Figure 1. Schematic diagram (1/2 LM158W)

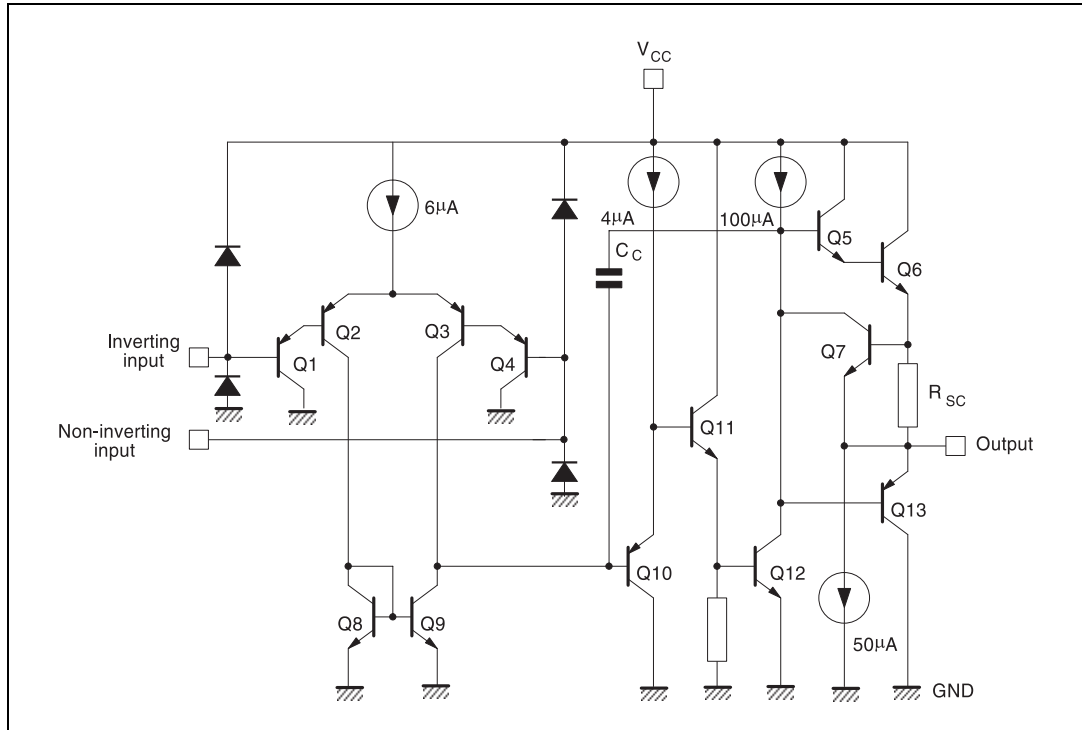

2 Absolute maximum ratings and operating conditions

Table 1. Absolute maximum ratings

Symbol	Parameter	LM158W/AW	LM258W/AW	LM358W/AW	Unit
V_{CC}	Supply voltage	+32			V
V_i	Input voltage	-0.3 to $V_{CC} + 0.3$			V
V_{id}	Differential input voltage	-0.3 to $V_{CC} + 0.3$			V
P_{tot}	Power dissipation ⁽¹⁾	500			mW
	Output short-circuit duration ⁽²⁾	Infinite			
I_{in}	Input current ⁽³⁾	50			mA
T_{oper}	Operating free-air temperature range	-55 to +125	-40 to +105	0 to +70	°C
T_{stg}	Storage temperature range	-65 to +150			°C
R_{thja}	Thermal resistance junction to ambient ^{(4) (5)}				°C/W
	SO-8	125			
	MiniSO-8	190			
	TSSOP8	120			
	DIP-8	85			
R_{thjc}	Thermal resistance junction to case				°C/W
	SO-8	40			
	MiniSO-8	39			
	TSSOP8	37			
	DIP-8	41			
ESD	HBM: human body model ⁽⁶⁾	2			kV
	MM: machine model ⁽⁷⁾	200			V
	CDM: charged device model ⁽⁸⁾	1.5			kV

1. Power dissipation must be considered to ensure maximum junction temperature (T_j) is not exceeded.
2. Short-circuits from the output to V_{CC} can cause excessive heating if $V_{CC} > 15V$. The maximum output current is approximately 40 mA independent of the magnitude of V_{CC} . Destructive dissipation can result from simultaneous short-circuits on all amplifiers.
3. This input current only exists when the voltage at any of the input leads is driven negative. It is due to the collector-base junction of the input PNP transistor becoming forward biased and thereby acting as input diode clamps. In addition to this diode action, there is also NPN parasitic action on the IC chip. This transistor action can cause the output voltages of the Op-amps to go to the V_{CC} voltage level (or to ground for a large overdrive) for the time during which an input is driven negative. This is not destructive and normal output will be restored for input voltage higher than -0.3 V.
4. Short-circuits can cause excessive heating and destructive dissipation.
5. R_{th} are typical values.
6. Human body model: 100 pF discharged through a 1.5 kΩ resistor between two pins of the device, done for all couples of pin combinations with other pins floating.
7. Machine model: a 200 pF cap is charged to the specified voltage, then discharged directly between two pins of the device with no external series resistor (internal resistor < 5 Ω), done for all couples of pin combinations with other pins floating.
8. Charged device model: all pins plus package are charged together to the specified voltage and then discharged directly to the ground.

Table 2. Operating conditions

Symbol	Parameter	Value	Unit
V_{CC}	Supply voltage	3 to 32	V
V_{icm}	Common mode input voltage range $T_{amb} = +25^{\circ}C$	$V_{DD} - 0.3$ to $V_{CC} - 1.5$	V
T_{oper}	Operating free air temperature range LM158W LM258W LM358W LM258WY-LM358WY	-55 - +125 -40 - +105 0 - +70 -40 - +125	$^{\circ}C$

3 Electrical characteristics

Table 3. $V_{CC}^+ = +5\text{ V}$, $V_{CC}^- = \text{Ground}$, $V_o = 1.4\text{ V}$, $T_{\text{amb}} = +25^\circ\text{C}$ (unless otherwise specified)

Symbol	Parameter	LM158AW-LM258AW LM358AW			LM158W-LM258W LM358W			Unit
		Min.	Typ.	Max.	Min.	Typ.	Max.	
V_{io}	Input offset voltage ⁽¹⁾ $T_{\text{amb}} = +25^\circ\text{C}$ - except LM158AW/358W $T_{\text{amb}} = +25^\circ\text{C}$ - LM158AW/358W		1	3		2	5	mV
	$T_{\text{min}} \leq T_{\text{amb}} \leq T_{\text{max}}$ - except LM358W $T_{\text{min}} \leq T_{\text{amb}} \leq T_{\text{max}}$ - LM358W		1	2		2	7	mV
I_{io}	Input offset current $T_{\text{amb}} = +25^\circ\text{C}$ $T_{\text{min}} \leq T_{\text{amb}} \leq T_{\text{max}}$		2	10		2	30	nA
				30			40	
I_{ib}	Input bias current ⁽²⁾ $T_{\text{amb}} = +25^\circ\text{C}$ $T_{\text{min}} \leq T_{\text{amb}} \leq T_{\text{max}}$		20	50		20	150	nA
				100			200	
A_{vd}	Large signal voltage gain: $V_{CC} = +15\text{ V}$, $R_L = 2\text{ k}\Omega$, $V_o = 1.4\text{ V}$ to 11.4 V $T_{\text{amb}} = +25^\circ\text{C}$ $T_{\text{min}} \leq T_{\text{amb}} \leq T_{\text{max}}$	50	100		50	100		V/mV
		25			25			
SVR	Supply voltage rejection ratio ($R_s \leq 10\text{ k}\Omega$) $V_{CC}^+ = 5\text{ V}$ to 30 V $T_{\text{amb}} = +25^\circ\text{C}$ $T_{\text{min}} \leq T_{\text{amb}} \leq T_{\text{max}}$	65	100		65	100		dB
		65			65			
I_{CC}	Supply current, all amp, no load $T_{\text{min}} \leq T_{\text{amb}} \leq T_{\text{max}}$, $V_{CC} = +5\text{ V}$ $T_{\text{min}} \leq T_{\text{amb}} \leq T_{\text{max}}$, $V_{CC} = +30\text{ V}$		0.7	1.2		0.7	1.2	mA
				2			2	
V_{icm}	Input common mode voltage range $V_{CC} = +30\text{ V}$ ⁽³⁾ $T_{\text{amb}} = +25^\circ\text{C}$ $T_{\text{min}} \leq T_{\text{amb}} \leq T_{\text{max}}$	0		$V_{CC}^+ - 1.5$	0		$V_{CC}^+ - 1.5$	V
		0		$V_{CC}^+ - 2$	0		$V_{CC}^+ - 2$	
CMR	Common mode rejection ratio ($R_s \leq 10\text{ k}\Omega$) $T_{\text{amb}} = +25^\circ\text{C}$ $T_{\text{min}} \leq T_{\text{amb}} \leq T_{\text{max}}$	70	85		70	85		dB
		60			60			
I_{source}	Output current source $V_{CC} = +15\text{ V}$, $V_o = +2\text{ V}$, $V_{id} = +1\text{ V}$	20	40	60	20	40	60	mA
I_{sink}	Output sink current ($V_{id} = -1\text{ V}$) $V_{CC} = +15\text{ V}$, $V_o = +2\text{ V}$ $V_{CC} = +15\text{ V}$, $V_o = +0.2\text{ V}$	10	20		10	20		mA
		12	50		12	50		μA

Table 3. $V_{CC}^+ = +5\text{ V}$, $V_{CC}^- = \text{Ground}$, $V_o = 1.4\text{ V}$, $T_{\text{amb}} = +25^\circ\text{C}$ (unless otherwise specified)

Symbol	Parameter	LM158AW-LM258AW LM358AW			LM158W-LM258W LM358W			Unit
		Min.	Typ.	Max.	Min.	Typ.	Max.	
V_{OPP}	Output voltage swing ($R_L = 2\text{ k}\Omega$) $T_{\text{amb}} = +25^\circ\text{C}$ $T_{\text{min}} \leq T_{\text{amb}} \leq T_{\text{max}}$	0 0		$V_{CC}^+ - 1.5$ $V_{CC}^+ - 2$	0 0		$V_{CC}^+ - 1.5$ $V_{CC}^+ - 2$	V
V_{OH}	High level output voltage ($V_{CC}^+ = 30\text{ V}$) $T_{\text{amb}} = +25^\circ\text{C}$, $R_L = 2\text{ k}\Omega$ $T_{\text{min}} \leq T_{\text{amb}} \leq T_{\text{max}}$ $T_{\text{amb}} = +25^\circ\text{C}$, $R_L = 10\text{ k}\Omega$ $T_{\text{min}} \leq T_{\text{amb}} \leq T_{\text{max}}$	26 26 27 27	27 28 		26 26 27 27	27 28 		V
V_{OL}	Low level output voltage ($R_L = 10\text{ k}\Omega$) $T_{\text{amb}} = +25^\circ\text{C}$ $T_{\text{min}} \leq T_{\text{amb}} \leq T_{\text{max}}$		5	20 20		5	20 20	mV
SR	Slew rate $V_{CC} = 15\text{ V}$, $V_i = 0.5\text{ to }3\text{ V}$, $R_L = 2\text{ k}\Omega$ $C_L = 100\text{ pF}$, unity Gain	0.3	0.6		0.3	0.6		V/ μs
GBP	Gain bandwidth product $V_{CC} = 30\text{ V}$, $f = 100\text{ kHz}$, $V_{\text{in}} = 10\text{ mV}$, $R_L = 2\text{ k}\Omega$ $C_L = 100\text{ pF}$	0.7	1.1		0.7	1.1		MHz
THD	Total harmonic distortion $f = 1\text{ kHz}$, $A_v = 20\text{ dB}$, $R_L = 2\text{ k}\Omega$, $V_o = 2\text{ V}_{\text{pp}}$ $C_L = 100\text{ pF}$, $V_o = 2\text{ V}_{\text{pp}}$		0.02			0.02		%
e_n	Equivalent input noise voltage $f = 1\text{ kHz}$, $R_s = 100\ \Omega$, $V_{CC} = 30\text{ V}$		55			55		$\frac{\text{nV}}{\sqrt{\text{Hz}}}$
DV_{io}	Input offset voltage drift		7	15		7	30	$\mu\text{V}/^\circ\text{C}$
DI_{io}	Input offset current drift		10	200		10	300	$\text{pA}/^\circ\text{C}$
V_{o1}/V_{o2}	Channel separation ⁽⁴⁾ $1\text{ kHz} \leq f \leq 20\text{ kHz}$		120			120		dB

- $V_o = 1.4\text{ V}$, $R_s = 0\ \Omega$, $5\text{ V} < V_{CC}^+ < 30\text{ V}$, $0 < V_{\text{ic}} < V_{CC}^+ - 1.5\text{ V}$
- The direction of the input current is out of the IC. This current is essentially constant, independent of the state of the output so there is no load change on the input lines.
- The input common-mode voltage of either input signal voltage should not be allowed to go negative by more than 0.3 V . The upper end of the common-mode voltage range is $V_{CC}^+ - 1.5\text{ V}$, but either or both inputs can go to $+32\text{ V}$ without damage.
- Due to the proximity of external components ensure that there is no coupling originating via stray capacitance between these external parts. Typically, this can be detected at higher frequencies because then this type of capacitance increases.

Figure 2. Open loop frequency response

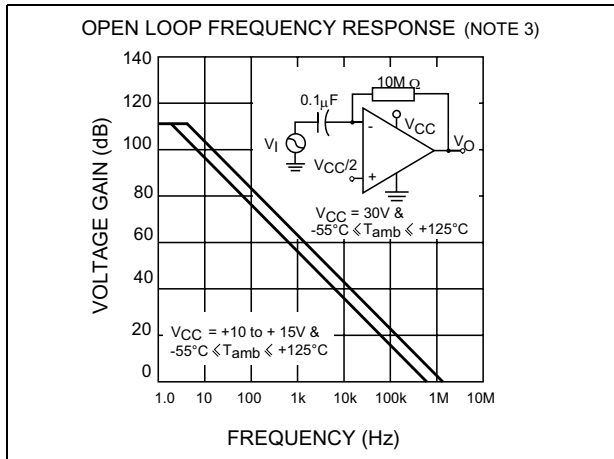

Figure 3. Large signal frequency response

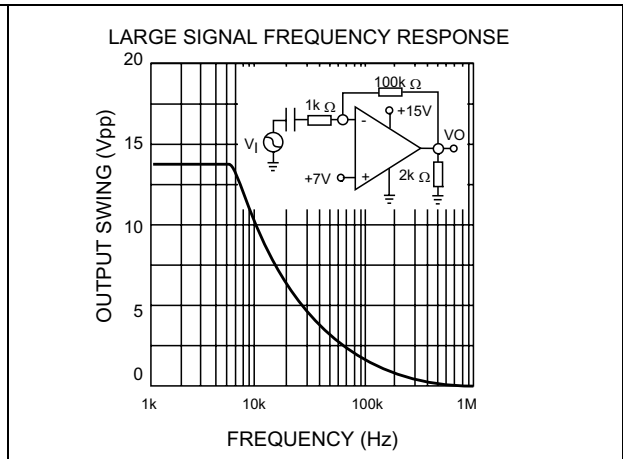

Figure 4. Voltage follower pulse response

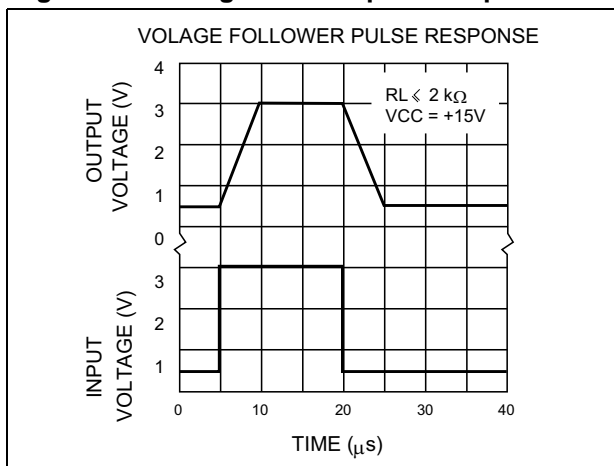

Figure 5. Voltage follower pulse response

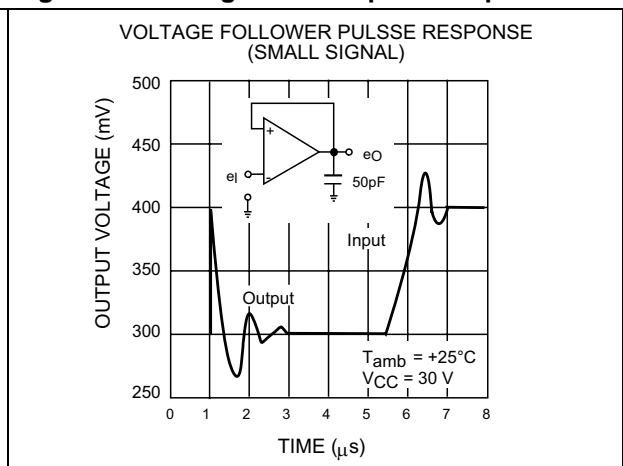

Figure 6. Input current

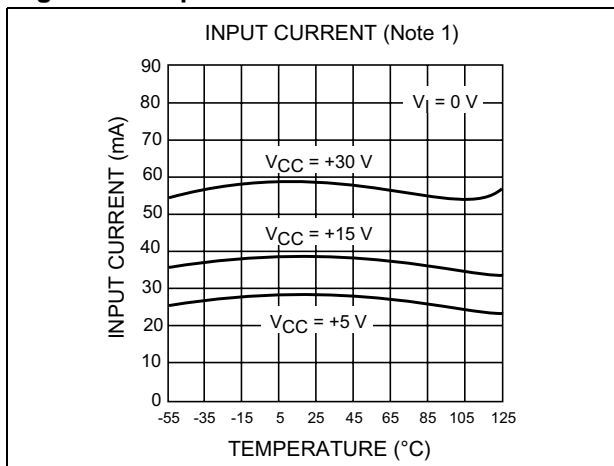

Figure 7. Output characteristics

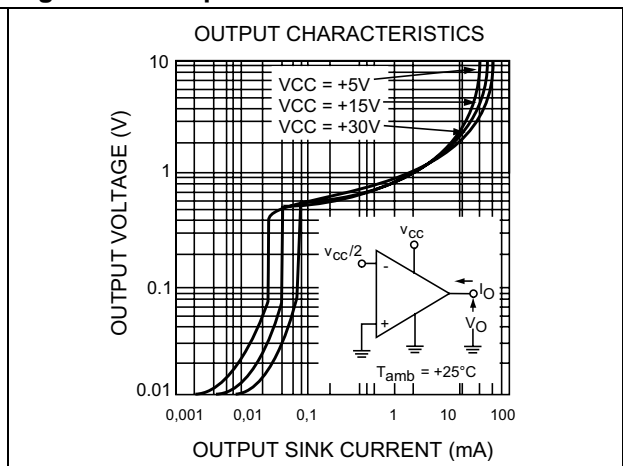

Figure 8. Output characteristics

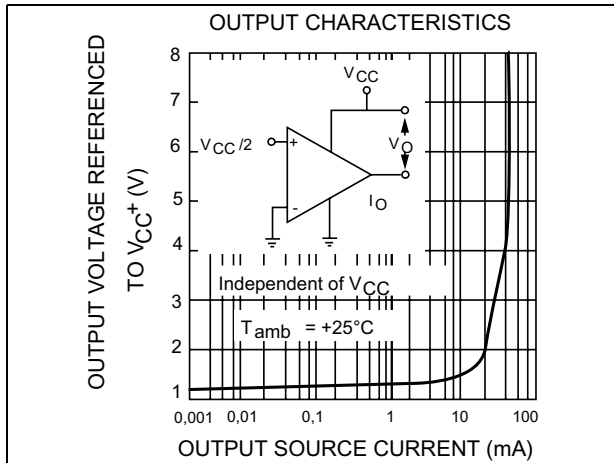

Figure 9. Current limiting

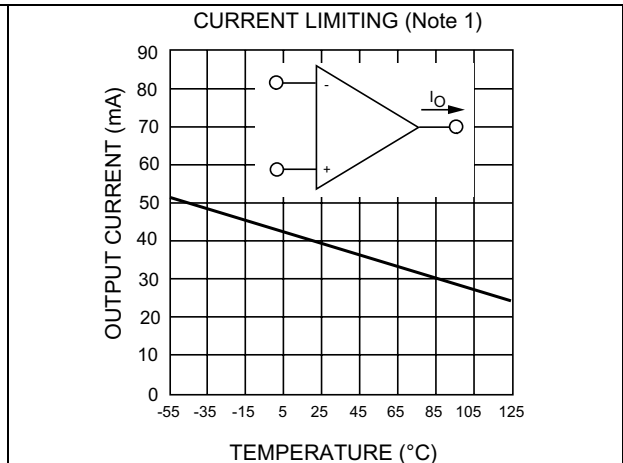

Figure 10. Input voltage range

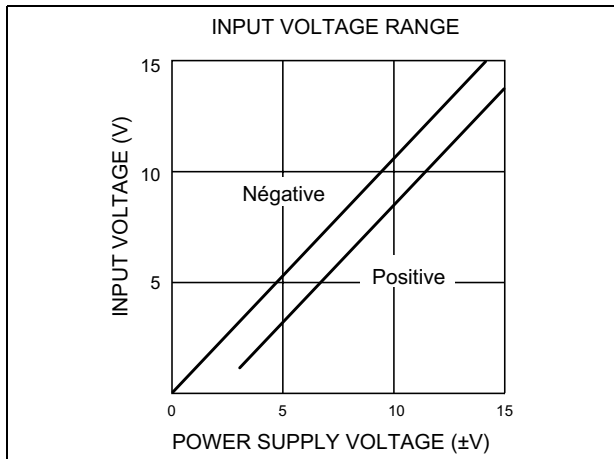

Figure 11. Positive supply voltage

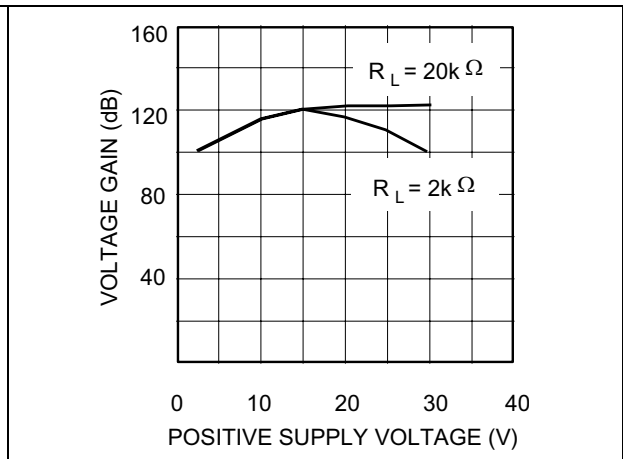

Figure 12. Input voltage range

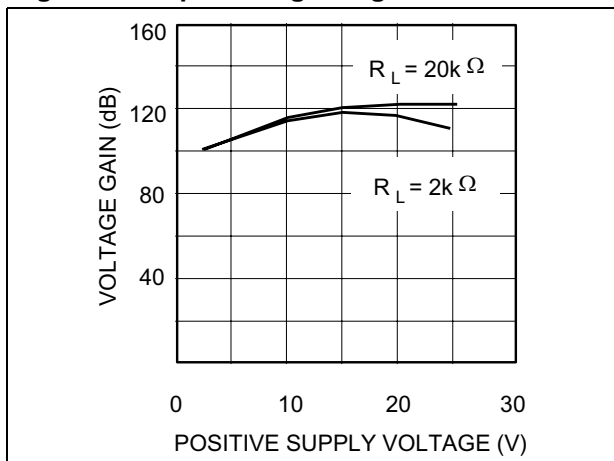

Figure 13. Supply current

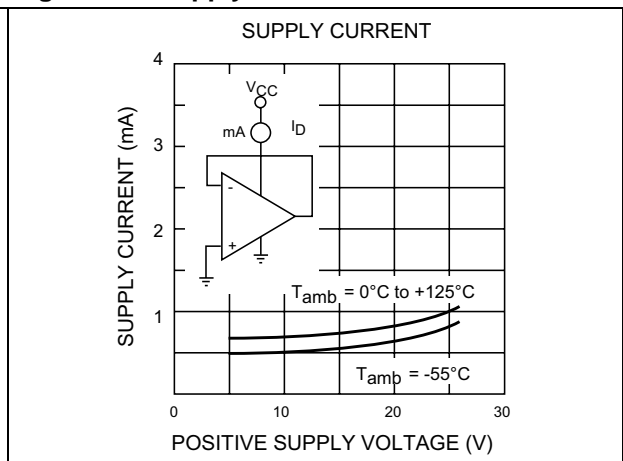

Figure 14. Input current

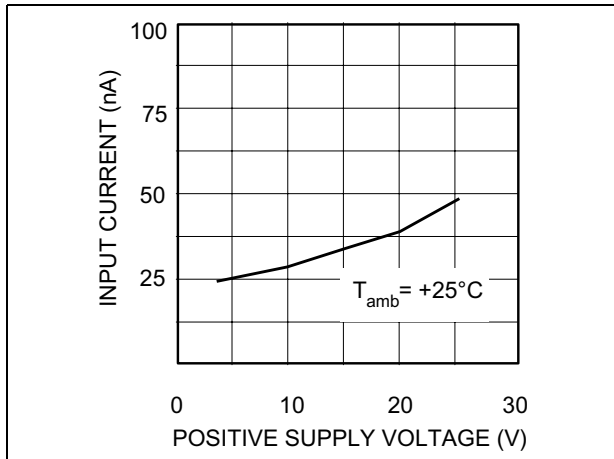

Figure 15. Gain bandwidth product

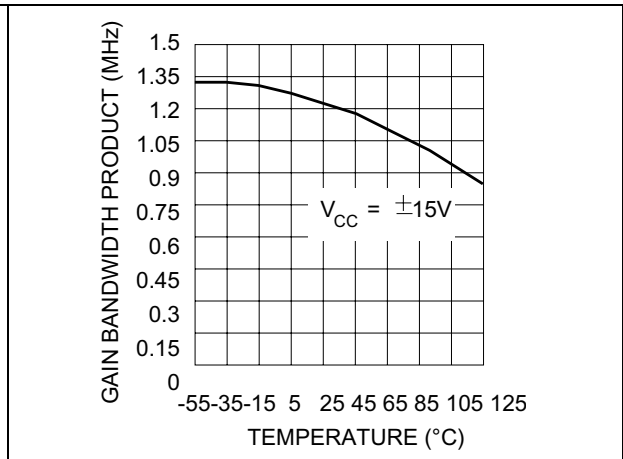

Figure 16. Power supply rejection ratio

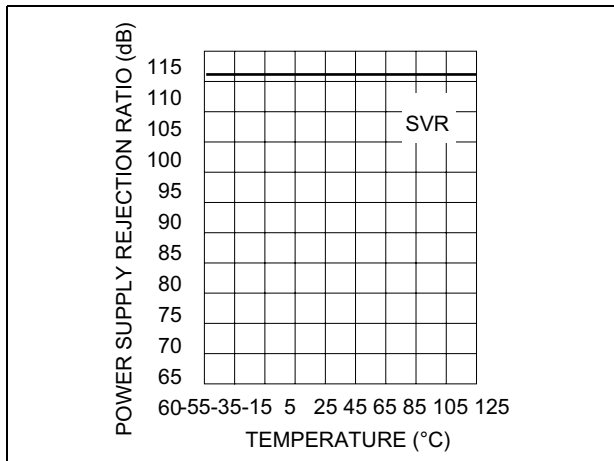

Figure 17. Common mode rejection ratio

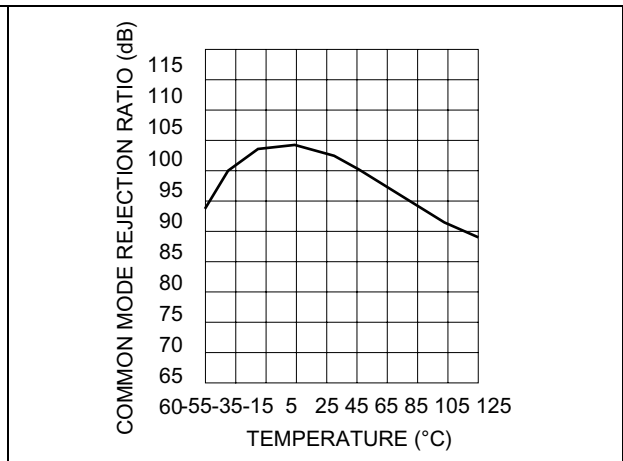
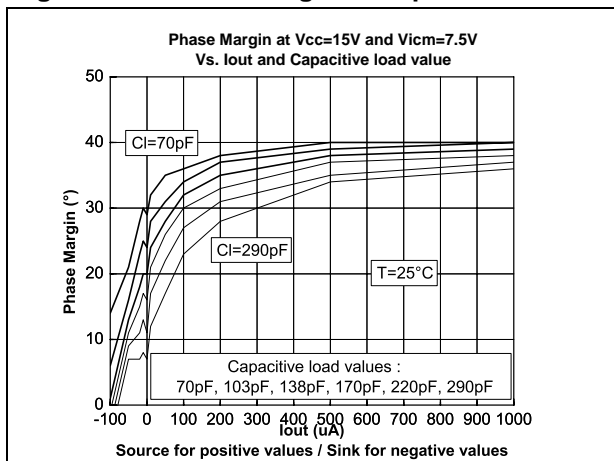

Figure 18. Phase margin vs capacitive load



4 Typical applications

Single supply voltage $V_{CC} = +5 V_{DC}$

Figure 19. AC coupled inverting amplifier

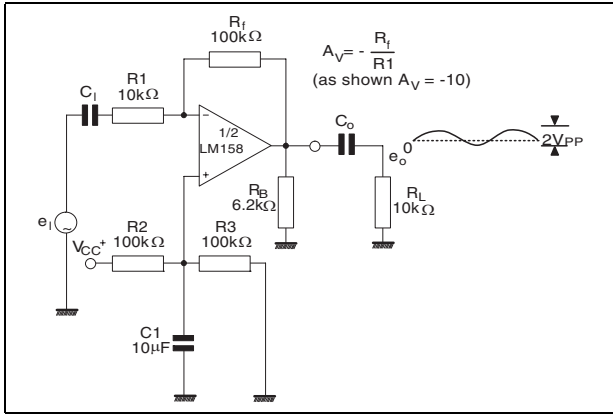

Figure 20. Non-inverting DC amplifier

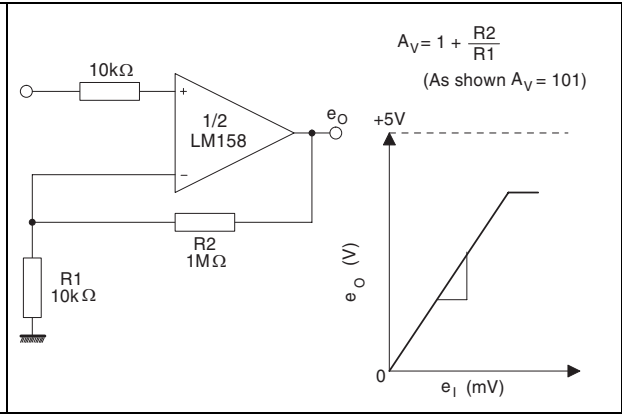

Figure 21. AC coupled non-inverting amplifier

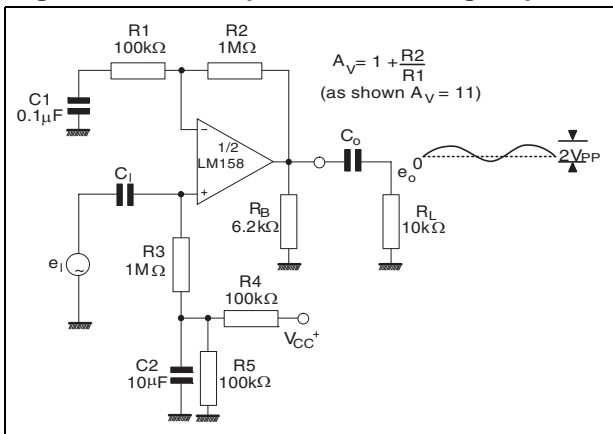

Figure 22. DC summing amplifier

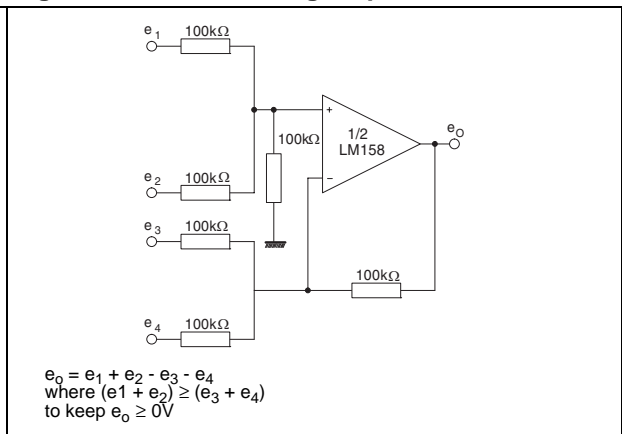

Figure 23. High input Z, DC differential amplifier

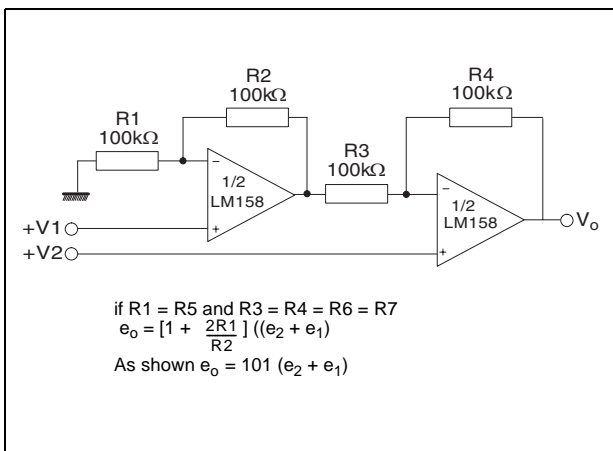

Figure 24. High input Z adjustable gain DC instrumentation amplifier

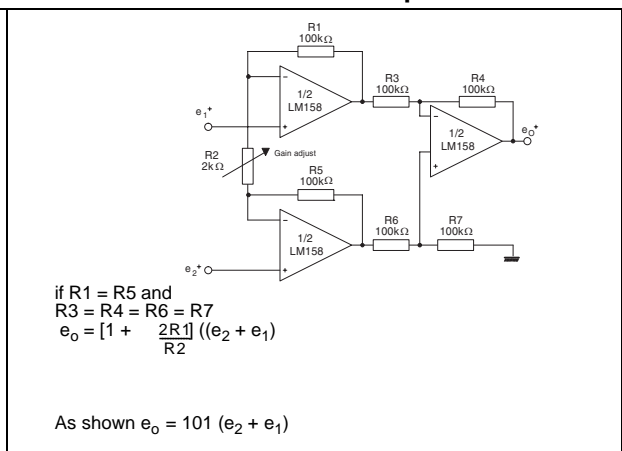

Figure 25. Using symmetrical amplifiers to reduce input current

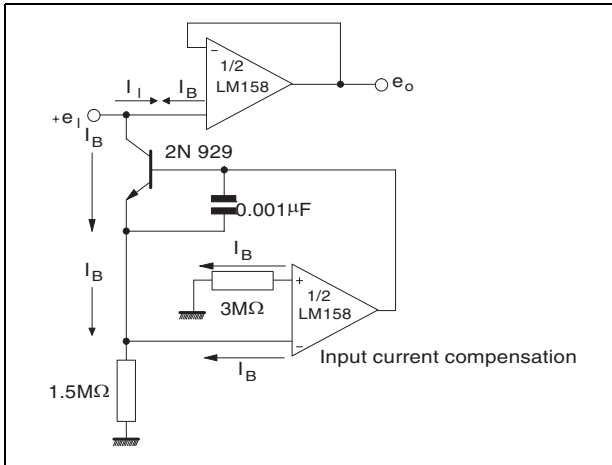

Figure 26. Low drift peak detector

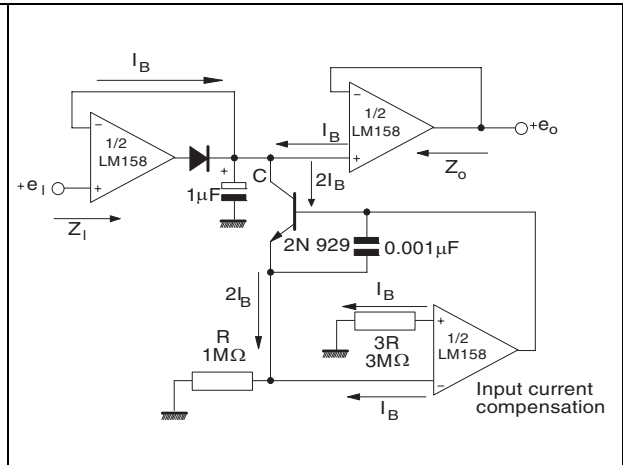
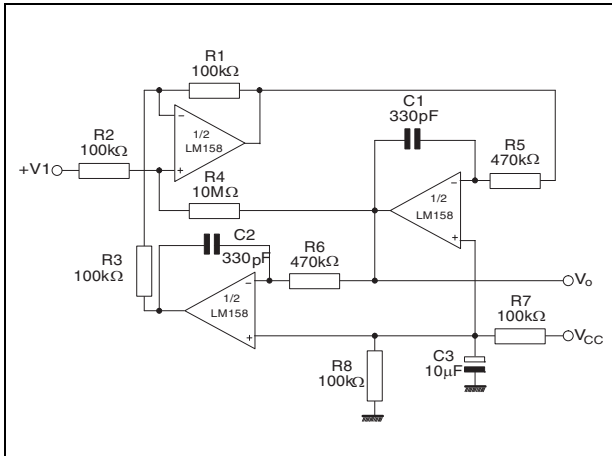

Figure 27. Active band-pass filter



5 Package mechanical data

In order to meet environmental requirements, STMicroelectronics offers these devices in ECOPACK[®] packages. These packages have a lead-free second level interconnect. The category of second level interconnect is marked on the package and on the inner box label, in compliance with JEDEC Standard JESD97. The maximum ratings related to soldering conditions are also marked on the inner box label. ECOPACK is an STMicroelectronics trademark. ECOPACK specifications are available at: www.st.com.

5.1 DIP8 package

Ref.	Dimensions					
	Millimeters			Inches		
	Min.	Typ.	Max.	Min.	Typ.	Max.
A		3.3			0.130	
a1	0.7			0.028		
B	1.39		1.65	0.055		0.065
B1	0.91		1.04	0.036		0.041
b		0.5			0.020	
b1	0.38		0.5	0.015		0.020
D			9.8			0.386
E		8.8			0.346	
e		2.54			0.100	
e3		7.62			0.300	
e4		7.62			0.300	
F			7.1			0.280
l			4.8			0.189
L		3.3			0.130	
Z	0.44		1.6	0.017		0.063

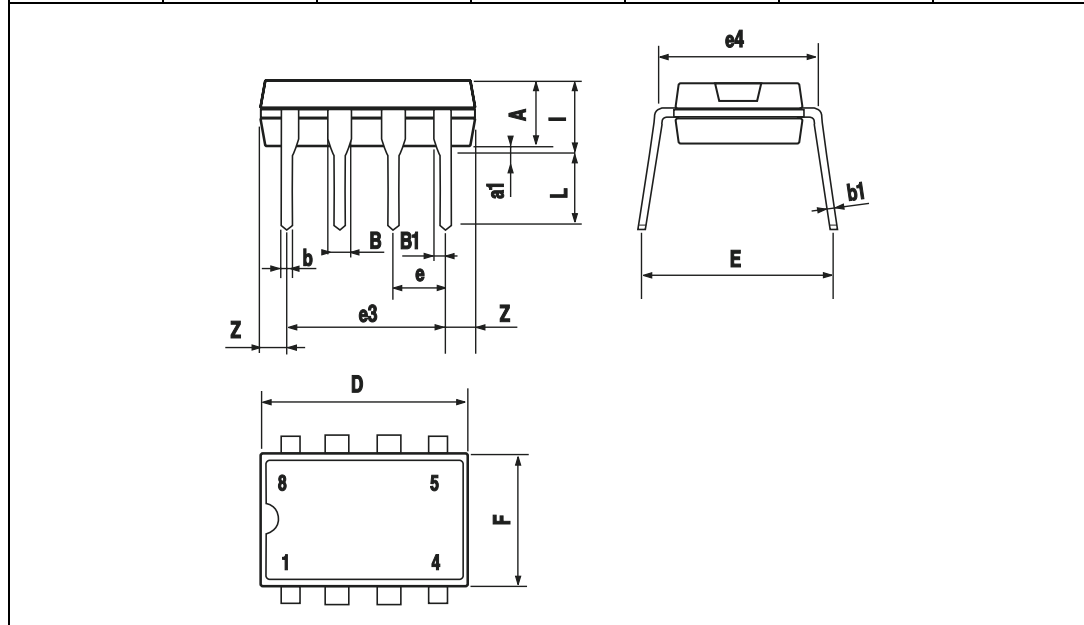

5.2 SO-8 package

Ref.	Dimensions					
	Millimeters			Inches		
	Min.	Typ.	Max.	Min.	Typ.	Max.
A	1.35		1.75	0.053		0.069
A1	0.10		0.25	0.04		0.010
A2	1.10		1.65	0.043		0.065
B	0.33		0.51	0.013		0.020
C	0.19		0.25	0.007		0.010
D	4.80		5.00	0.189		0.197
E	3.80		4.00	0.150		0.157
e		1.27			0.050	
H	5.80		6.20	0.228		0.244
h	0.25		0.50	0.010		0.020
L	0.40		1.27	0.016		0.050
k	8° (max.)					
ddd			0.1			0.04

5.3 MiniSO-8 package

Ref.	Dimensions					
	Millimeters			Inches		
	Min.	Typ.	Max.	Min.	Typ.	Max.
A			1.1			0.043
A1	0.05	0.10	0.15	0.002	0.004	0.006
A2	0.78	0.86	0.94	0.031	0.034	0.037
b	0.25	0.33	0.40	0.010	0.13	0.016
c	0.13	0.18	0.23	0.005	0.007	0.009
D	2.90	3.00	3.10	0.114	0.118	0.122
E	4.75	4.90	5.05	0.187	0.193	0.199
E1	2.90	3.00	3.10	0.114	0.118	0.122
e		0.65			0.026	
K	0°		6°	0°		6°
L	0.40	0.55	0.70	0.016	0.022	0.028
L1			0.10			0.004

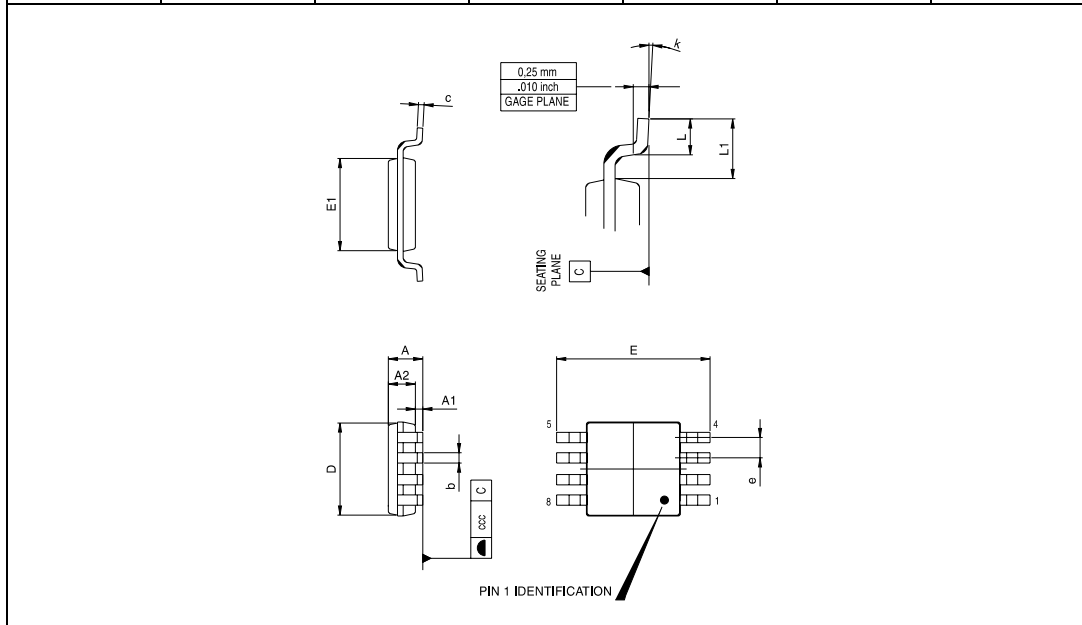

5.4 TSSOP8 package

Ref.	Dimensions					
	Millimeters			Inches		
	Min.	Typ.	Max.	Min.	Typ.	Max.
A			1.2			0.047
A1	0.05		0.15	0.002		0.006
A2	0.80	1.00	1.05	0.031	0.039	0.041
b	0.19		0.30	0.007		0.012
c	0.09		0.20	0.004		0.008
D	2.90	3.00	3.10	0.114	0.118	0.122
E	6.20	6.40	6.60	0.244	0.252	0.260
E1	4.30	4.40	4.50	0.169	0.173	0.177
e		0.65			0.0256	
K	0°		8°	0°		8°
L	0.45	0.60	0.75	0.018	0.024	0.030
L1		1			0.039	

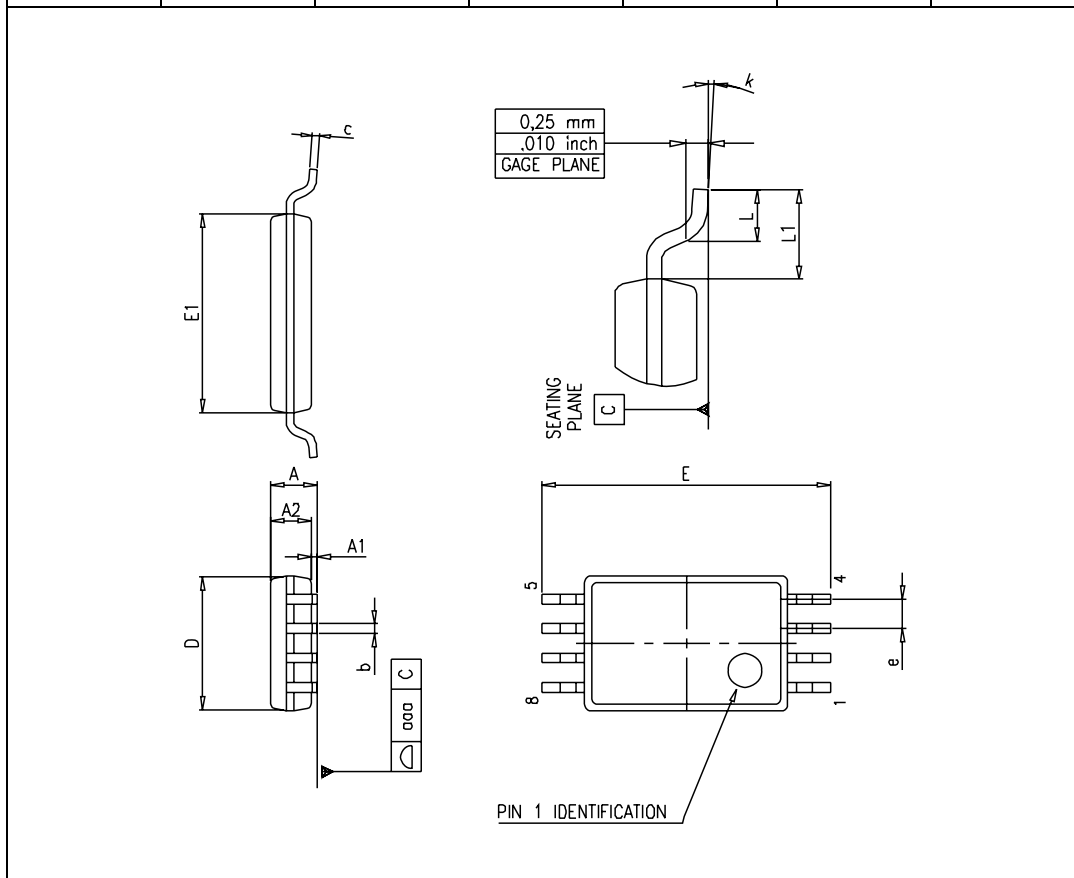

6 Ordering information

Part number	Temperature range	Package	Packaging	Marking
LM158WN	-55°C, +125°C	DIP-8	Tube	LM158WN
LM158WD LM158WDT		SO-8	Tube or tape & reel	158W
LM258WAN	-40°C, +105°C	DIP-8	Tube	LM258WA
LM258WAD LM258WADT		SO-8	Tube or tape & reel	258WA
LM258WN		DIP-8	Tube	LM258WN
LM258WD LM258WDT		SO-8	Tube or tape & reel	258W
LM358WN	0°C, +70°C	DIP-8	Tube	LM358WN
LM358WD LM358WDT		SO-8	Tube or tape & reel	358W
LM358AWD LM358AWDT				358AW
LM258WYPT (automotive grade) ⁽¹⁾	40°C, +125°C	TSSOP-8	Tape & reel	K411
LM258AWYPT (automotive grade) ⁽¹⁾		TSSOP-8	Tape & reel	K410
LM258WYD LM258WYDT (automotive grade) ⁽¹⁾		SO-8	Tube or tape & reel	258WY
LM258AWYD LM258AWYDT (automotive grade) ⁽¹⁾		SO-8	Tube or tape & reel	258AWY
LM358WYD LM358WYDT (automotive grade) ⁽¹⁾		SO-8	Tube or tape & reel	358WY
LM358AWYD LM358AWYDT (automotive grade) ⁽¹⁾		SO-8	Tube or tape & reel	358AWY
LM358WYPT (automotive grade) ⁽¹⁾		TSSOP-8	Tape & reel	K412
LM358AWYPT (automotive grade) ⁽¹⁾		TSSOP-8	Tape & reel	K413

1. Qualified and characterized according to AEC Q100 and Q003 or equivalent, advanced screening according to AEC Q001 & Q 002 or equivalent.

7 Revision history

Date	Revision	Changes
1-Nov-2002	1	First release.
1-Jul-2005	2	ESD protection inserted in Table 1: Absolute maximum ratings on page 4 .
6-Oct-2006	3	ESD tolerance for model HBM improved to 2kV (Table 1: Absolute maximum ratings on page 4). R_{thja} and R_{thjc} typical values added in Table 1: Absolute maximum ratings on page 4 . Added Figure 18: Phase margin vs capacitive load on page 10 .
2-Jan-2007	4	Order codes added (automotive grade level) to Section 6: Ordering information .
15-Mar-2007	5	Previously called revision 4. Footnote for automotive grade order codes added to Section 6: Ordering information .
25-Apr-2007	6	Added missing Revision 4 of January 2007 in revision history. Corrected revision number of March 2007 to Revision 5.

Please Read Carefully:

Information in this document is provided solely in connection with ST products. STMicroelectronics NV and its subsidiaries ("ST") reserve the right to make changes, corrections, modifications or improvements, to this document, and the products and services described herein at any time, without notice.

All ST products are sold pursuant to ST's terms and conditions of sale.

Purchasers are solely responsible for the choice, selection and use of the ST products and services described herein, and ST assumes no liability whatsoever relating to the choice, selection or use of the ST products and services described herein.

No license, express or implied, by estoppel or otherwise, to any intellectual property rights is granted under this document. If any part of this document refers to any third party products or services it shall not be deemed a license grant by ST for the use of such third party products or services, or any intellectual property contained therein or considered as a warranty covering the use in any manner whatsoever of such third party products or services or any intellectual property contained therein.

UNLESS OTHERWISE SET FORTH IN ST'S TERMS AND CONDITIONS OF SALE ST DISCLAIMS ANY EXPRESS OR IMPLIED WARRANTY WITH RESPECT TO THE USE AND/OR SALE OF ST PRODUCTS INCLUDING WITHOUT LIMITATION IMPLIED WARRANTIES OF MERCHANTABILITY, FITNESS FOR A PARTICULAR PURPOSE (AND THEIR EQUIVALENTS UNDER THE LAWS OF ANY JURISDICTION), OR INFRINGEMENT OF ANY PATENT, COPYRIGHT OR OTHER INTELLECTUAL PROPERTY RIGHT.

UNLESS EXPRESSLY APPROVED IN WRITING BY AN AUTHORIZED ST REPRESENTATIVE, ST PRODUCTS ARE NOT RECOMMENDED, AUTHORIZED OR WARRANTED FOR USE IN MILITARY, AIR CRAFT, SPACE, LIFE SAVING, OR LIFE SUSTAINING APPLICATIONS, NOR IN PRODUCTS OR SYSTEMS WHERE FAILURE OR MALFUNCTION MAY RESULT IN PERSONAL INJURY, DEATH, OR SEVERE PROPERTY OR ENVIRONMENTAL DAMAGE. ST PRODUCTS WHICH ARE NOT SPECIFIED AS "AUTOMOTIVE GRADE" MAY ONLY BE USED IN AUTOMOTIVE APPLICATIONS AT USER'S OWN RISK.

Resale of ST products with provisions different from the statements and/or technical features set forth in this document shall immediately void any warranty granted by ST for the ST product or service described herein and shall not create or extend in any manner whatsoever, any liability of ST.

ST and the ST logo are trademarks or registered trademarks of ST in various countries.

Information in this document supersedes and replaces all information previously supplied.

The ST logo is a registered trademark of STMicroelectronics. All other names are the property of their respective owners.

© 2007 STMicroelectronics - All rights reserved

STMicroelectronics group of companies

Australia - Belgium - Brazil - Canada - China - Czech Republic - Finland - France - Germany - Hong Kong - India - Israel - Italy - Japan - Malaysia - Malta - Morocco - Singapore - Spain - Sweden - Switzerland - United Kingdom - United States of America

www.st.com