

**ADJUSTABLE PRECISION SHUNT REGULATORS****AN431****General Description**

The AN431 series ICs are three-terminal adjustable shunt regulators with guaranteed thermal stability over a full operation range. These ICs feature sharp turn-on characteristics, low temperature coefficient and low output impedance, which make them ideal substitutes for Zener diodes in applications such as switching power supply, charger and other adjustable regulators.

The output voltage of these ICs can be set to any value between  $V_{REF}$  (2.5V) and the maximum cathode voltage (36V).

The AN431 precision reference is offered in two voltage tolerance: 0.5% and 1.0%.

These ICs are available in SOT-23 package.

**Features**

- Programmable Precise Output Voltage from 2.5V to 36V
- High Stability under Capacitive Load
- Low Temperature Deviation: 4.5mV Typical
- Low Equivalent Full-range Temperature Coefficient with 20PPM/°C Typical
- Low Dynamic Output Resistance: 0.15Ω Typical
- Sink Current Capacity from 1mA to 100mA
- Low Output Noise
- Wide Operating Range of -40 to 125°C

**Applications**

- Charger
- Voltage Adapter
- Switching Power Supply
- Graphic Card
- Precision Voltage Reference



Figure 1. Package Type of AN431



**ADJUSTABLE PRECISION SHUNT REGULATORS**

**AN431**

**Pin Configuration**

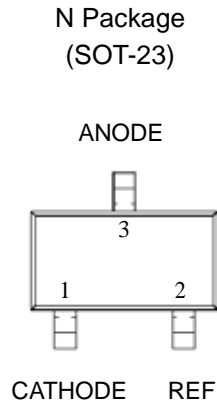

Figure 2. Pin Configuration of AN431 (Top View)

**Functional Block Diagram**

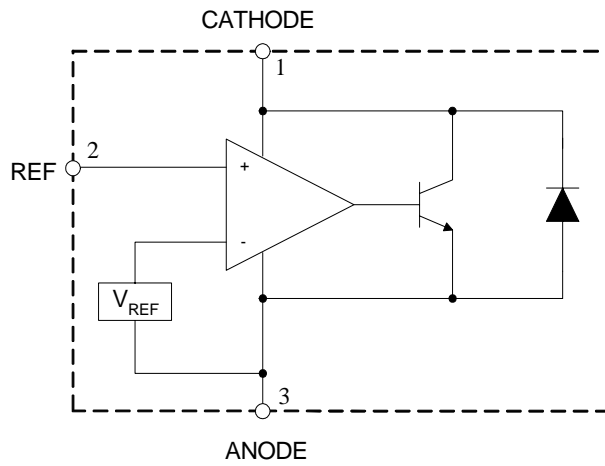

Figure 3. Functional Block Diagram of AN431



**ADJUSTABLE PRECISION SHUNT REGULATORS**

**AN431**

**Ordering Information**

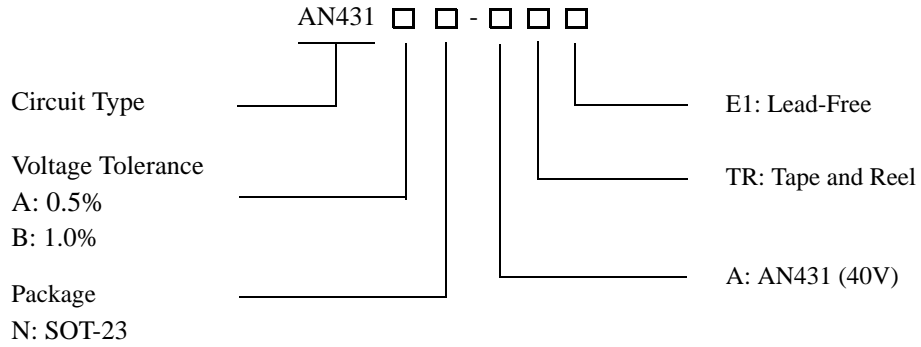

Package	Temperature Range	Voltage Tolerance	Part Number	Marking ID	Packing Type
SOT-23	-40 to 125°C	0.5%	AN431AN-ATRE1	EB1	Tape & Reel
		1.0%	AN431BN-ATRE1	EB2	Tape & Reel

BCD Semiconductor's Pb-free products, as designated with "E1" suffix in the part number, are RoHS compliant.

**ADJUSTABLE PRECISION SHUNT REGULATORS****AN431****Absolute Maximum Ratings (Note 1)**

Parameter	Symbol	Value	Unit
Cathode Voltage	$V_{KA}$	40	V
Cathode Current Range (Continuous)	$I_{KA}$	-100 to 150	mA
Reference Input Current Range	$I_{REF}$	10	mA
Power Dissipation	$P_D$	370	mW
Junction Temperature	$T_J$	150	°C
Storage Temperature Range	$T_{STG}$	-65 to 150	°C
ESD (Human Body Model)	ESD	2000	V

Note 1: Stresses greater than those listed under "Absolute Maximum Ratings" may cause permanent damage to the device. These are stress ratings only, and functional operation of the device at these or any other conditions beyond those indicated under "Recommended Operating Conditions" is not implied. Exposure to "Absolute Maximum Ratings" for extended periods may affect device reliability.

**Recommended Operating Conditions**

Parameter	Symbol	Min	Max	Unit
Cathode Voltage	$V_{KA}$	$V_{REF}$	36	V
Cathode Current	$I_{KA}$	1.0	100	mA
Operating Ambient Temperature Range		-40	125	°C



**ADJUSTABLE PRECISION SHUNT REGULATORS**

**AN431**

**Electrical Characteristics**

Operating Conditions:  $T_A=25^{\circ}\text{C}$ , unless otherwise specified.

Parameter	Test Circuit	Symbol	Conditions	Min	Typ	Max	Unit	
Reference Voltage	0.5%	4	$V_{\text{REF}}$	$V_{\text{KA}}=V_{\text{REF}}, I_{\text{KA}}=10\text{mA}$	2.487	2.500	2.512	V
	1.0%				2.475	2.500	2.525	
Deviation of Reference Voltage Over Full Temperature Range	4	$\Delta V_{\text{REF}}$	$V_{\text{KA}}=V_{\text{REF}}, I_{\text{KA}}=10\text{mA}$	0 to $70^{\circ}\text{C}$	4.5	8	mV	
				-40 to $85^{\circ}\text{C}$	4.5	10		
				-40 to $125^{\circ}\text{C}$	4.5	16		
Ratio of Change in Reference Voltage to the Change in Cathode Voltage	5	$\frac{\Delta V_{\text{REF}}}{\Delta V_{\text{KA}}}$	$I_{\text{KA}}=10\text{mA}$	$\Delta V_{\text{KA}}=10\text{V to } V_{\text{REF}}$	-1.0	-2.7	mV/V	
				$\Delta V_{\text{KA}}=36\text{V to } 10\text{V}$	-0.5	-2.0		
Reference Current	5	$I_{\text{REF}}$	$I_{\text{KA}}=10\text{mA}, R1=10\text{K}\Omega, R2=\infty$		0.7	4	$\mu\text{A}$	
Deviation of Reference Current Over Full Temperature Range	5	$\Delta I_{\text{REF}}$	$I_{\text{KA}}=10\text{mA}, R1=10\text{K}\Omega, R2=\infty, T_A=-40 \text{ to } 125^{\circ}\text{C}$		0.4	1.2	$\mu\text{A}$	
Minimum Cathode Current for Regulation	4	$I_{\text{KA}}(\text{Min})$	$V_{\text{KA}}=V_{\text{REF}}$		0.4	1.0	mA	
Off-state Cathode Current	6	$I_{\text{KA}}(\text{Off})$	$V_{\text{KA}}=36\text{V}, V_{\text{REF}}=0$		0.05	1.0	$\mu\text{A}$	
Dynamic Impedance	4	$Z_{\text{KA}}$	$V_{\text{KA}}=V_{\text{REF}}, I_{\text{KA}}=1 \text{ to } 100\text{mA}, f \leq 1.0\text{kHz}$		0.15	0.5	$\Omega$	



**ADJUSTABLE PRECISION SHUNT REGULATORS**

**AN431**

**Electrical Characteristics (Continued)**

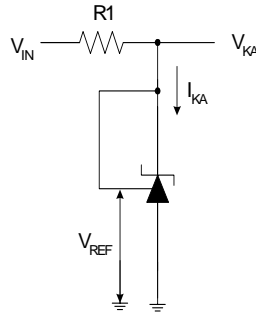

Figure 4. Test Circuit 4 for  $V_{KA}=V_{REF}$

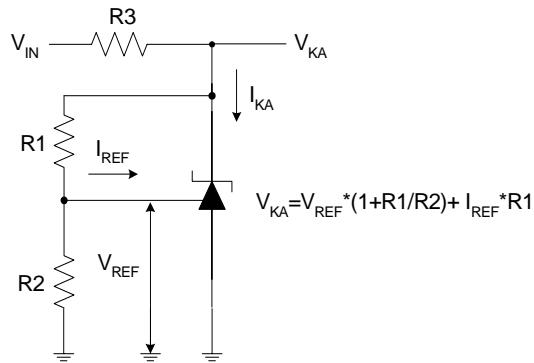

Figure 5. Test Circuit 5 for  $V_{KA}>V_{REF}$

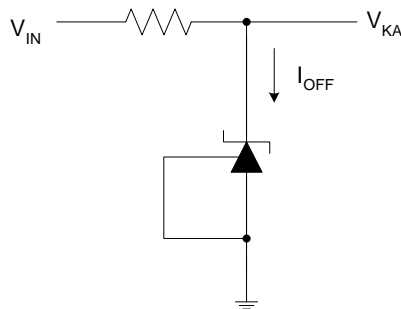

Figure 6. Test Circuit 6 for  $I_{OFF}$



**ADJUSTABLE PRECISION SHUNT REGULATORS**

**AN431**

**Typical Performance Characteristics**

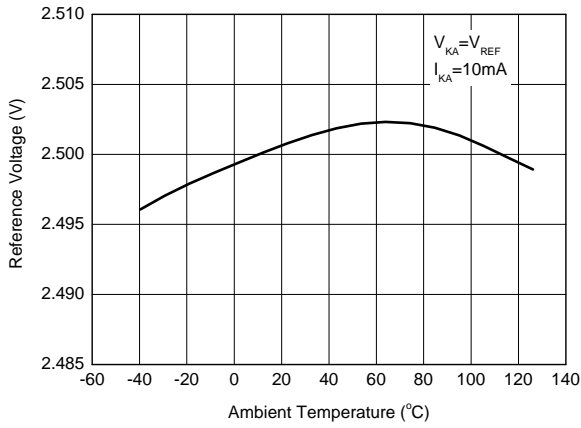

Figure 7. Reference Voltage vs. Ambient Temperature

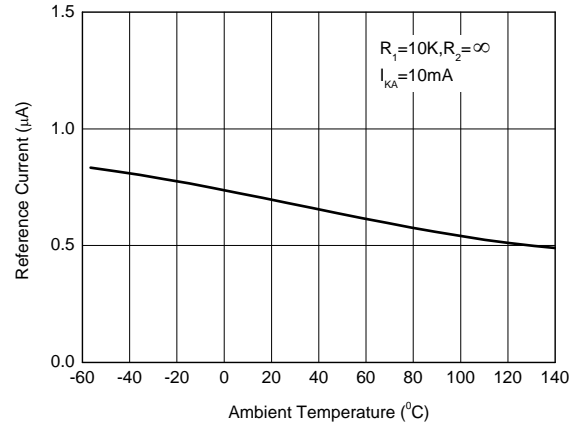

Figure 8. Reference Current vs. Ambient Temperature

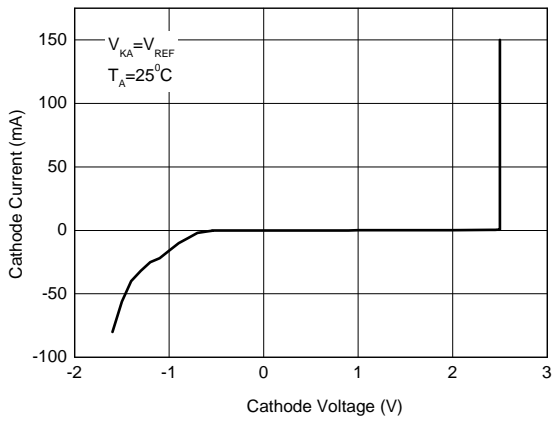

Figure 9. Cathode Current vs. Cathode Voltage

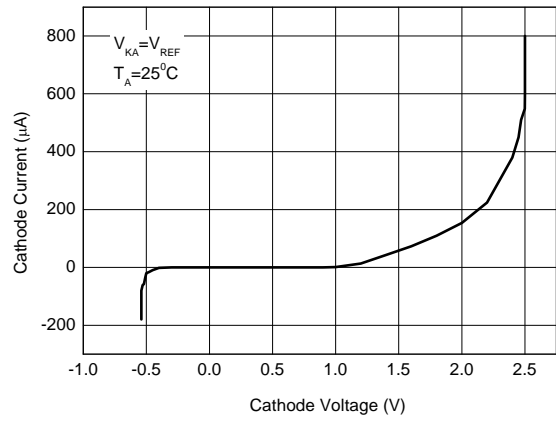

Figure 10. Cathode Current vs. Cathode Voltage



**ADJUSTABLE PRECISION SHUNT REGULATORS**

**AN431**

**Typical Performance Characteristics (Continued)**

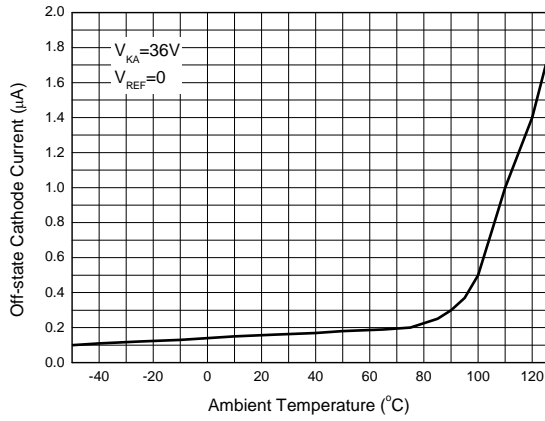

Figure 11. Off-state Cathode Current vs. Ambient Temperature

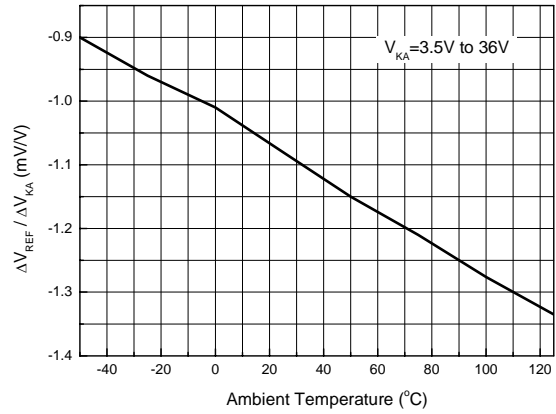

Figure 12. Ratio of Delta Reference Voltage to the Ratio of Delta Cathode Voltage

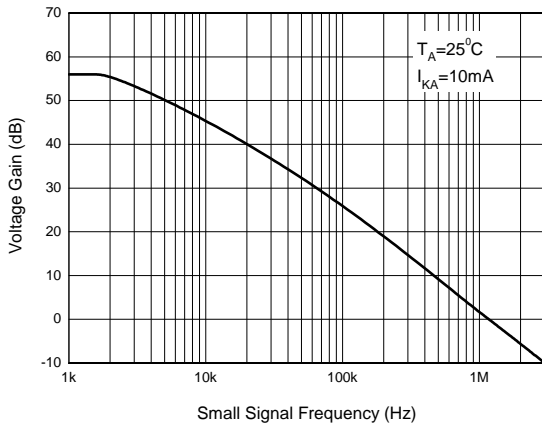
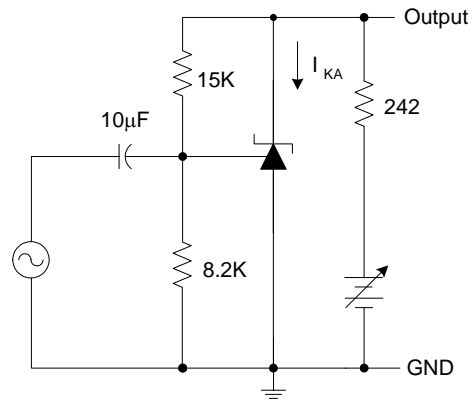

Figure 13. Small Signal Voltage Gain vs. Frequency







**ADJUSTABLE PRECISION SHUNT REGULATORS**

**AN431**

**Typical Performance Characteristics (Continued)**

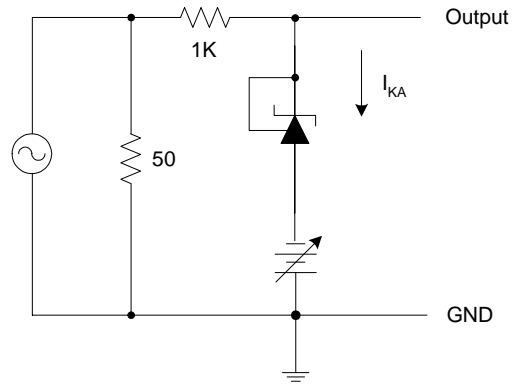
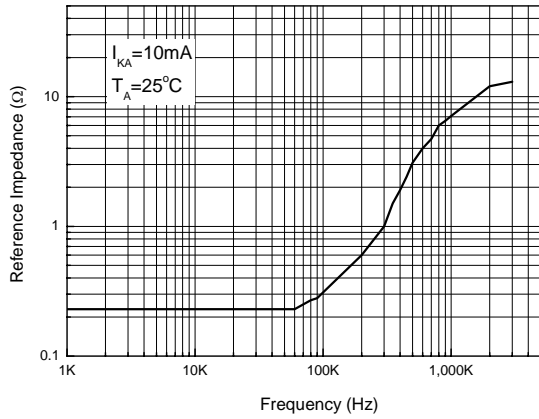

Figure 14. Reference Impedance vs. Frequency

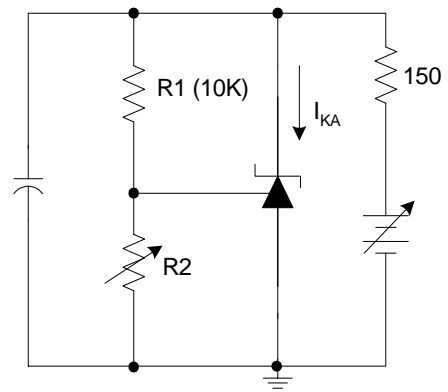
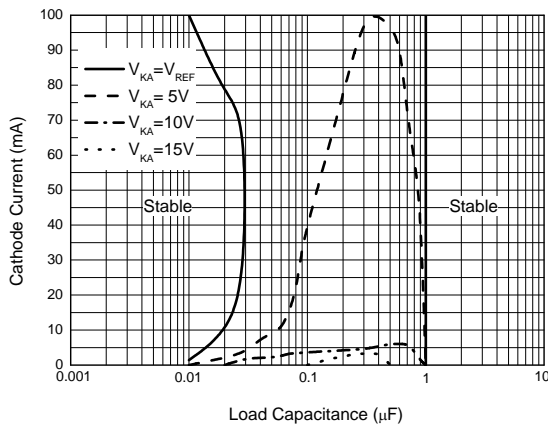

Figure 15. Stability Boundary Conditions vs. Load Capacitance



**ADJUSTABLE PRECISION SHUNT REGULATORS**

**AN431**

**Typical Performance Characteristics (Continued)**

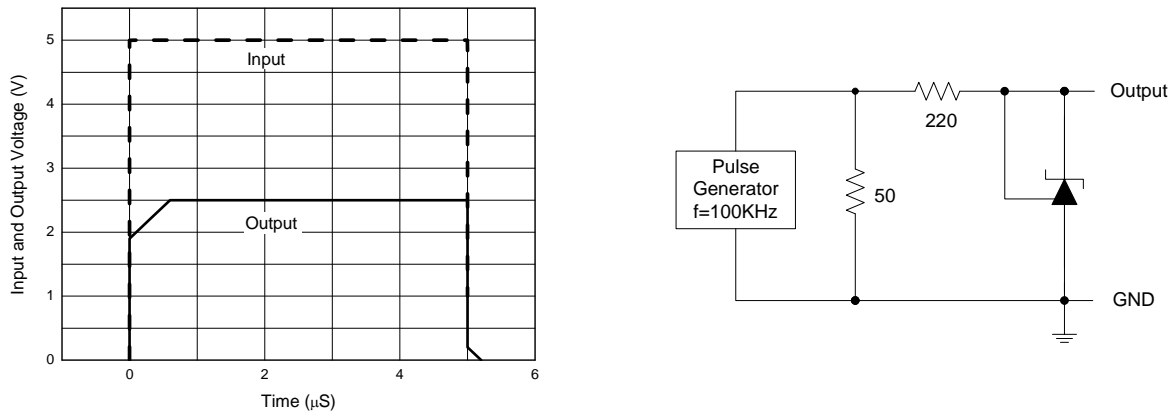

Figure 16. Pulse Response of Input and Output Voltage



**ADJUSTABLE PRECISION SHUNT REGULATORS**

**AN431**

**Typical Application**

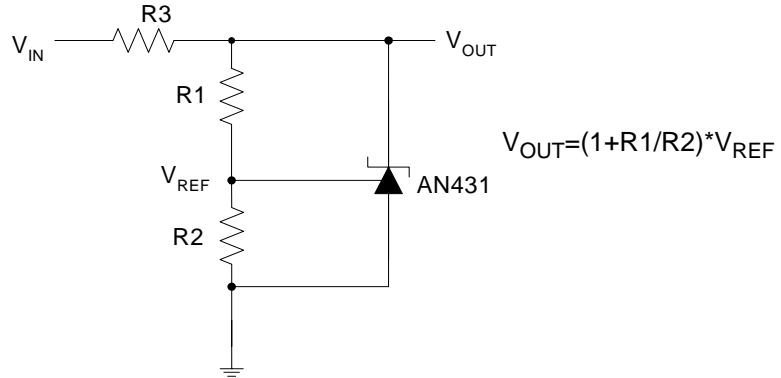

Figure 17. Shunt Regulator

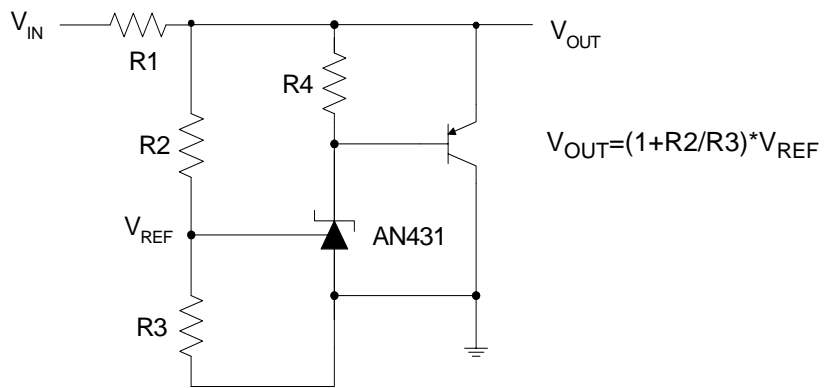

Figure 18. High Current Shunt Regulator

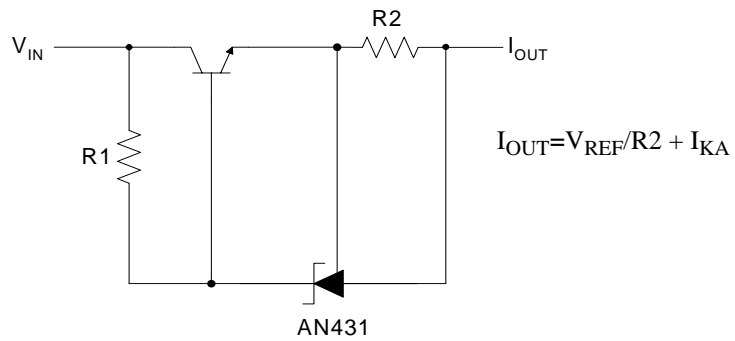

Figure 19. Current Source or Current Limit



**ADJUSTABLE PRECISION SHUNT REGULATORS**

**AN431**

**Typical Application (Continued)**

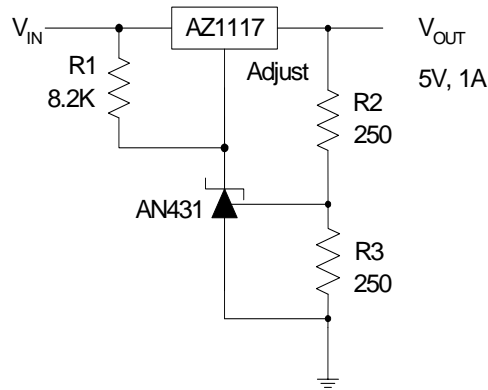

Figure 20. Precision 5V 1A Regulator

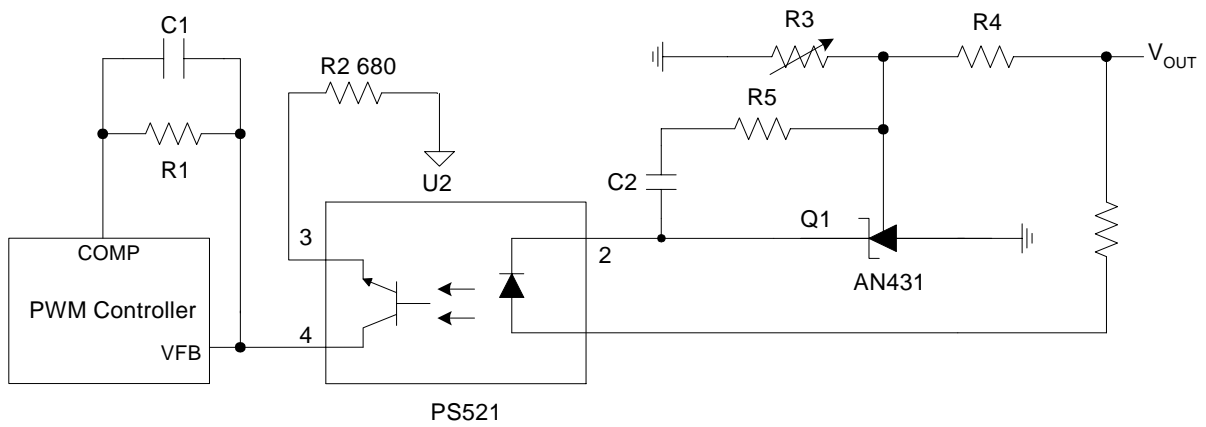

Figure 21. PWM Converter with Reference



**ADJUSTABLE PRECISION SHUNT REGULATORS**

**AN431**

**Mechanical Dimensions**

**SOT-23**

**Unit: mm(inch)**

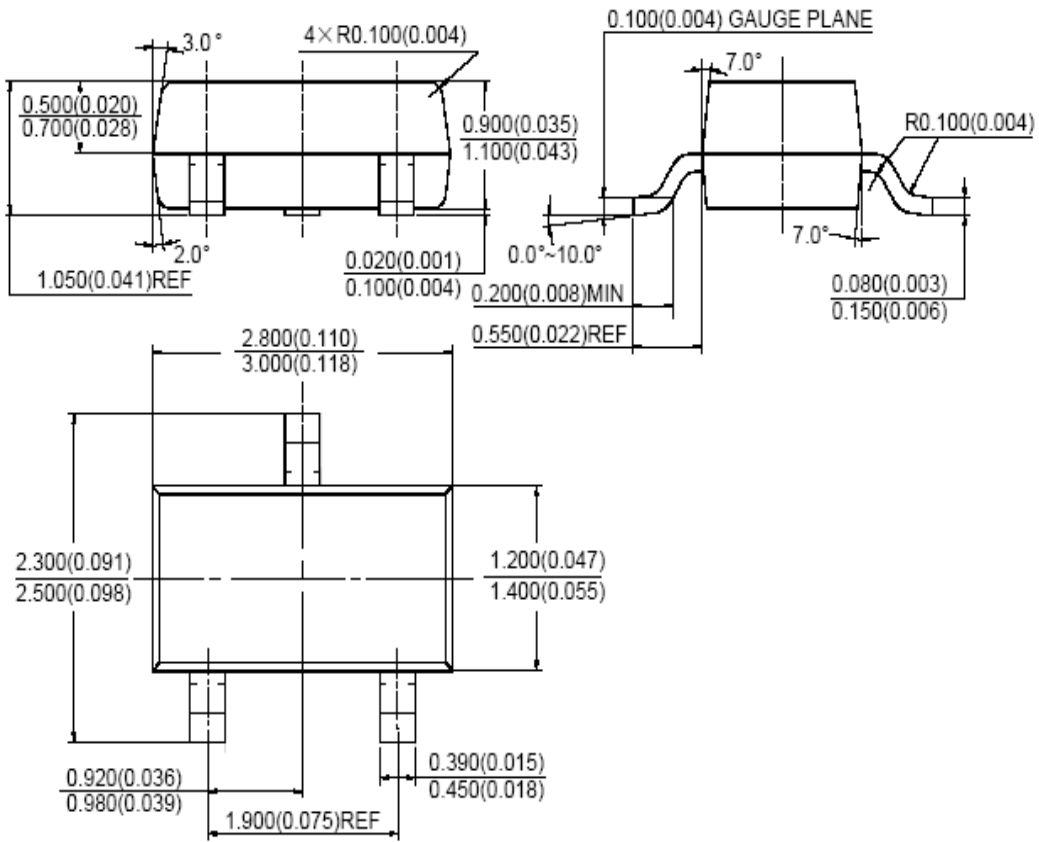



BCD Semiconductor Manufacturing Limited

<http://www.bcdsemi.com>

### IMPORTANT NOTICE

BCD Semiconductor Manufacturing Limited reserves the right to make changes without further notice to any products or specifications herein. BCD Semiconductor Manufacturing Limited does not assume any responsibility for use of any its products for any particular purpose, nor does BCD Semiconductor Manufacturing Limited assume any liability arising out of the application or use of any its products or circuits. BCD Semiconductor Manufacturing Limited does not convey any license under its patent rights or other rights nor the rights of others.

---

#### MAIN SITE

**BCD Semiconductor Manufacturing Limited**  
- Wafer Fab  
Shanghai SIM-BCD Semiconductor Manufacturing Limited  
800, Yi Shan Road, Shanghai 200233, China  
Tel: +86-21-6485 1491, Fax: +86-21-5450 0008

**BCD Semiconductor Manufacturing Limited**  
- IC Design Group  
Advanced Analog Circuits (Shanghai) Corporation  
8F, Zone B, 900, Yi Shan Road, Shanghai 200233, China  
Tel: +86-21-6495 9539, Fax: +86-21-6485 9673

#### REGIONAL SALES OFFICE

**Shenzhen Office**  
Shanghai SIM-BCD Semiconductor Manufacturing Co., Ltd. Shenzhen Office  
Advanced Analog Circuits (Shanghai) Corporation Shenzhen Office  
Room E, 5F, Noble Center, No.1006, 3rd Fuzhong Road, Futian District, Shenzhen 518026, China  
Tel: +86-755-8826 7951  
Fax: +86-755-8826 7865

**Taiwan Office**  
BCD Semiconductor (Taiwan) Company Limited  
4F, 298-1, Rui Guang Road, Nei-Hu District, Taipei,  
Taiwan  
Tel: +886-2-2656 2808  
Fax: +886-2-2656 2806

**USA Office**  
BCD Semiconductor Corporation  
30920 Huntwood Ave. Hayward,  
CA 94544, U.S.A  
Tel : +1-510-324-2988  
Fax: +1-510-324-2788