



A4533

LINEAR INTEGRATED CIRCUIT

LOW POWER AMPLIFIER FOR HEADPHONE STEREOS

■ FEATURES

- * Low current consumption.
- * 16Ω load drive capability.
- * Excellent reduced voltage characteristics.
- * High power supply ripple rejection.
- * Fewer external components required.
- * High voltage gain.
- * Less harmonic interference in radio band.
- * Built in power switch and muting function.

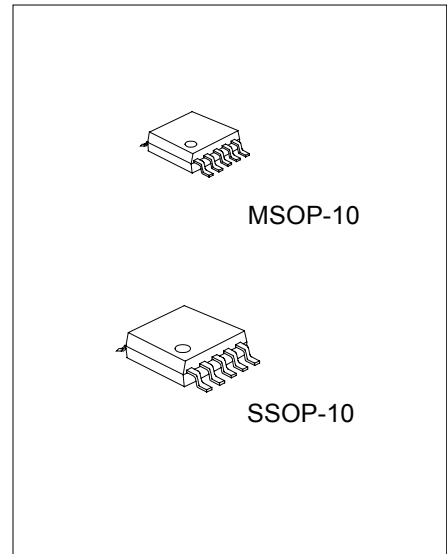

*Pb-free plating product number: A4533L

■ ORDERING INFORMATION

Order Number		Package	Packing
Normal	Lead Free Plating		
A4533-SM2-R	A4533L-SM2-R	MSOP-10	Tape & Reel
A4533-SM2-T	A4533L-SM2-T	MSOP-10	Tube
A4533-R10-R	A4533L-R10-R	SSOP-10	Tape & Reel
A4533-R10-T	A4533L-R10-T	SSOP-10	Tube

■ BLOCK DIAGRAM

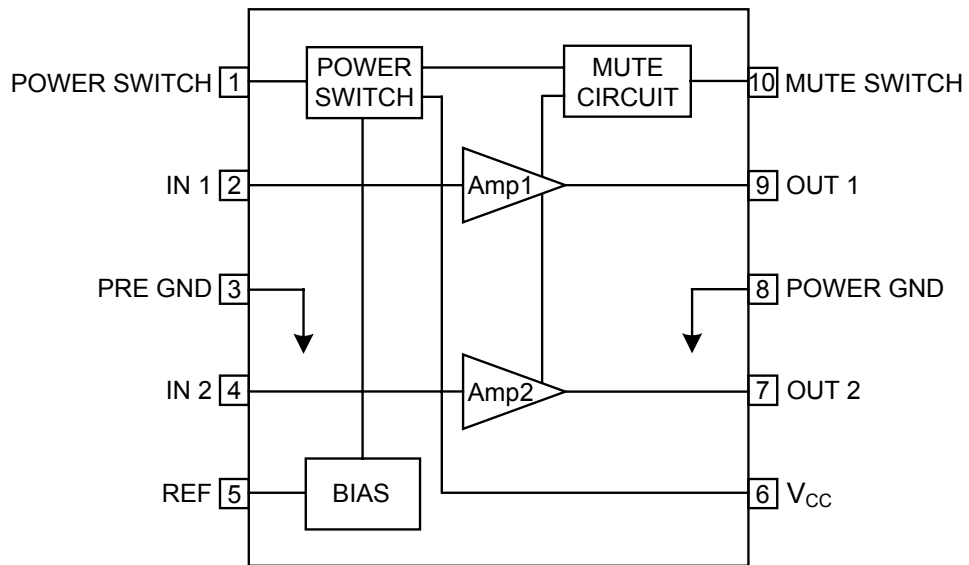

■ ABSOLUTE MAXIMUM RATINGS ($T_A = 25^\circ\text{C}$)

PARAMETER	SYMBOL	RATINGS	UNIT
Power Supply Voltage	V_{CC}	4.5	V
Power Dissipation	P_D	300	mW
Junction Temperature	T_J	125	
Operating Temperature	T_{OPR}	0 ~ +70	
Storage Temperature	T_{STG}	-40 ~ +150	

Note 1. Absolute maximum ratings are those values beyond which the device could be permanently damaged. Absolute maximum ratings are stress ratings only and functional device operation is not implied.

2. The device is guaranteed to meet performance specification within 0 ~ 70 operating temperature range and assured by design from -20 ~ 85 .

■ RECOMMENDED OPERATING CONDITIONS

PARAMETER	SYMBOL	RATINGS	UNIT
Supply Voltage	V_{CC}	3	V
Operating Voltage Range	V_{OPR}	1.6 ~ 4	V
Load Resistance	R_L	16 ~ 32	Ω

■ ELECTRICAL CHARACTERIS ($T_a = 25^\circ\text{C}$, $R_L=16\Omega$, $R_g=600\Omega$, Unless Otherwise specified)

PARAMETER	SYMBOL	CONDITIONS	MIN	TYP	MAX	UNIT
Quiescent Current	I_{Q1}	$V_{CC}=2.4V$		5.4	10	mA
	I_{Q2}	$V_{CC}=4.5V$, Mute =GND		1.1	2.0	mA
	I_{Q3}	$V_{CC}=4.5V$, PS = GND			1.0	μA
Voltage Gain	G_{V1}	$V_{CC}=2.4V$, $f=1\text{kHz}$, $V_{OUT}=-10\text{dBm}$	30	32	34	dB
	G_{V2}	$V_{CC}=1.6V$, $f=1\text{kHz}$, $V_{OUT}=-20\text{dBm}$	29	32	34	dB
Voltage Gain Difference	ΔG_{V1}	$V_{CC}=2.4V$, $f=1\text{kHz}$, $V_{OUT}=-10\text{dBm}$			1.0	dB
	ΔG_{V2}	$V_{CC}=1.6V$, $f=1\text{kHz}$, $V_{OUT}=-20\text{dBm}$			1.0	dB
Total Harmonic Distortion	THD	$V_{CC}=2.0V$, $f=1\text{kHz}$, $P_{OUT}=1\text{mW}$		0.5	1.5	%
Output Power	P_{OUT}	$V_{CC}=3.0V$, $f=1\text{kHz}$, THD=10%	20	40		mW
Cross Talk	CT	$V_{CC}=2.4V$, $f=100\text{Hz}$, $R_g=1\text{k}\Omega$, $V_{OUT}=-10\text{dB}$	40	50		dB
Ripple Rejection	RR	$V_{CC}=1.6V$, $f=100\text{Hz}$, $R_g=1\text{k}\Omega$, $V_R=-20\text{dBm}$, BPF=100Hz	45	60		dB
Output Noise Voltage	eN	$V_{CC}=4.5V$, $R_g=1\text{k}\Omega$, BPF=20Hz ~ 20kHz		62	100	μV
Power Off Effect	$V_{O(OFF)}$	$V_{CC}=1.6V$, $f=100\text{Hz}$, PS = GND, $V_{IN}=-10\text{dB}$			-80	dB
Muting Effect	$V_{O(MT)}$	$V_{CC}=1.6V$, $f=100\text{Hz}$, Mute = GND, $V_{IN}=-10\text{dB}$			-80	dB
Power On Current Sensitivity	$I_{PS(ON)}$	$V_{CC}=1.5V$, $V_{REF}\geq 0.85V$		0.05	1.0	μA
Power Off Voltage Sensitivity	$V_{PS(OFF)}$	$V_{CC}=1.5V$, $V_{REF}\leq 0.1V$	0.5	0.6		V
Muting Off Current Sensitivity	$I_{MUTE(OFF)}$	$V_{CC}=1.5V$, $V_{REF}\geq 0.85V$		0.2	1.0	μA
Muting On Voltage Sensitivity	$V_{MUTE(ON)}$	$V_{CC}=1.5V$, $V_{REF}\leq 0.1V$	0.5	0.65		V

Note: The quiescent current is represented by the current flowing into pin 6. The respective maximum currents flowing into pin 1 and pin 10 are calculated by $(\text{pin voltage} - 0.5) / 16 [\text{V}/\text{k}\Omega]$ and the total current increases by these current values.

TEST CIRCUIT

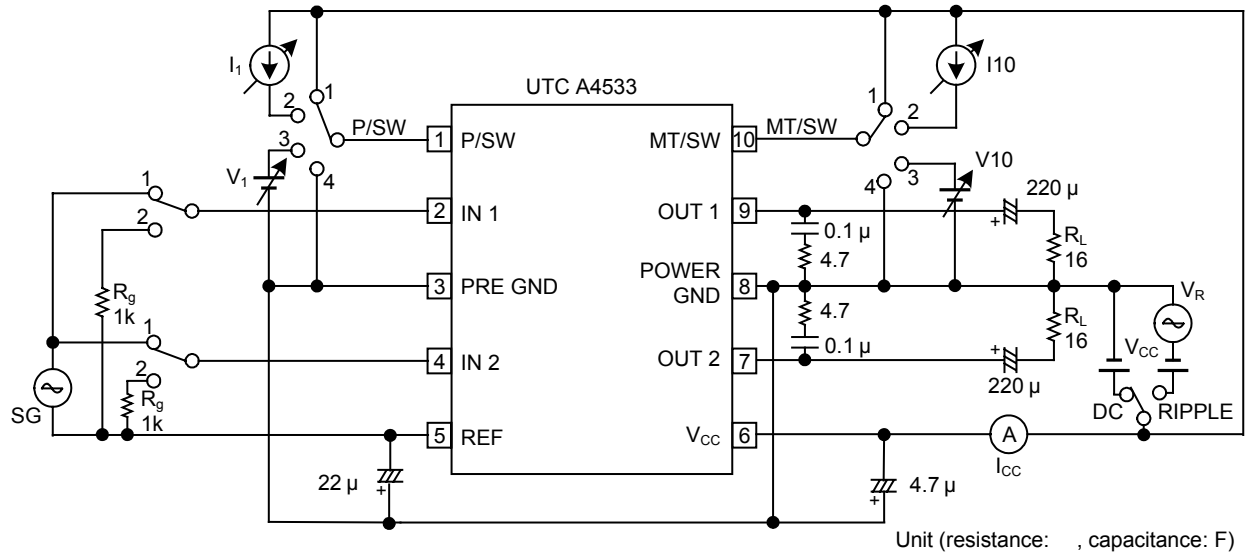

■ TYPICAL APPLICATION CIRCUIT

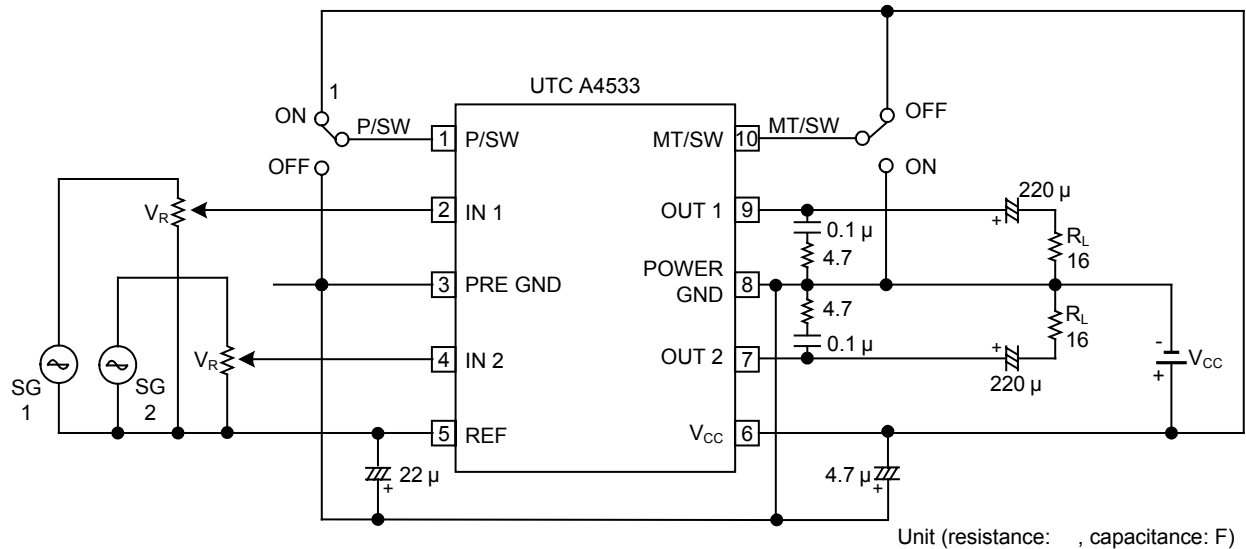

UTC assumes no responsibility for equipment failures that result from using products at values that exceed, even momentarily, rated values (such as maximum ratings, operating condition ranges, or other parameters) listed in products specifications of any and all UTC products described or contained herein. UTC products are not designed for use in life support appliances, devices or systems where malfunction of these products can be reasonably expected to result in personal injury. Reproduction in whole or in part is prohibited without the prior written consent of the copyright owner. The information presented in this document does not form part of any quotation or contract, is believed to be accurate and reliable and may be changed without notice.