

# Photoflash Capacitor Charger in ThinSOT™

October 2003

## FEATURES

- Highly Integrated IC Reduces Solution Size
- Uses Small Transformers:  
5.8mm × 5.8mm × 3mm
- Fast Photoflash Charge Times:  
4.6s for LT3468 (0V to 320V, 100μF, V<sub>IN</sub> = 3.6V)  
5.5s for LT3468-1 (0V to 320V, 50μF, V<sub>IN</sub> = 3.6V)
- Controlled Input Current:  
500mA (LT3468)  
225mA (LT3468-1)
- Supports Operation from Single Li-Ion Cell, or Any Supply from 2.5V up to 16V
- Adjustable Output Voltage
- No Output Voltage Divider Needed
- Charges Any Size Photoflash Capacitor
- Low Profile (1mm) SOT-23 Package

## APPLICATIONS

- Digital / Film Camera Flash
- PDA / Cell Phone Flash
- Emergency Strobe

## DESCRIPTION

The LT<sup>®</sup>3468/LT3468-1 are highly integrated ICs designed to charge photoflash capacitors in digital and film cameras. A new control technique\* allows for the use of extremely small transformers. Each device contains an on-chip high voltage NPN power switch. Output voltage detection\* is completely contained within the device, eliminating the need for any discrete zener diodes or resistors. The output voltage can be adjusted by simply changing the turns ratio of the transformer. The LT3468 has a primary current limit of 1.4A while the LT3468-1 has a 0.7A limit. These different current limit levels result in well controlled input currents of 500mA for the LT3468 and 225mA for the LT3468-1. Aside from the differing current limit, the two devices are otherwise equivalent.

The CHARGE pin gives full control of the part to the user. Driving CHARGE low puts the part in shutdown. The DONE pin indicates when the part has completed charging. The LT3468 series of parts are housed in tiny low profile (1mm) SOT-23 packages.

LT, LTC and LT are registered trademarks of Linear Technology Corporation. ThinSOT is a trademark of Linear Technology Corporation. \*U.S. Patent # 6, 518, 733

## TYPICAL APPLICATIONS

**DANGER HIGH VOLTAGE – OPERATION BY HIGH VOLTAGE TRAINED PERSONNEL ONLY**

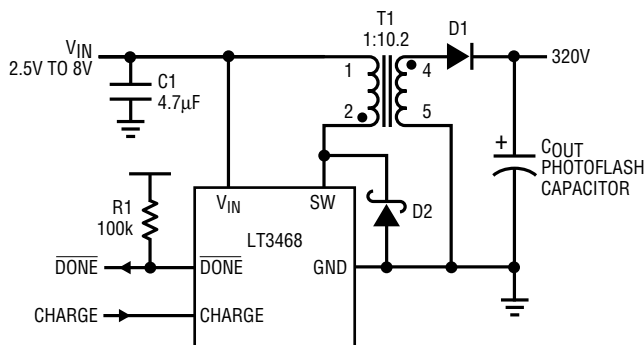

C1: 4.7μF, X5R OR X7R, 10V  
 T1: KIJIMA MUSEN PART# SBL-5.6-1, L<sub>PR1</sub> = 10μH, N = 10.2  
 D1: VISHAY GSD2004S DUAL DIODE CONNECTED IN SERIES  
 D2: ZETEX ZHCS400 OR EQUIVALENT  
 R1: PULL UP RESISTOR NEEDED IF DONE PIN USED

**Figure 1. LT3468 Photoflash Charger Uses High Efficiency 4mm Tall Transformer**

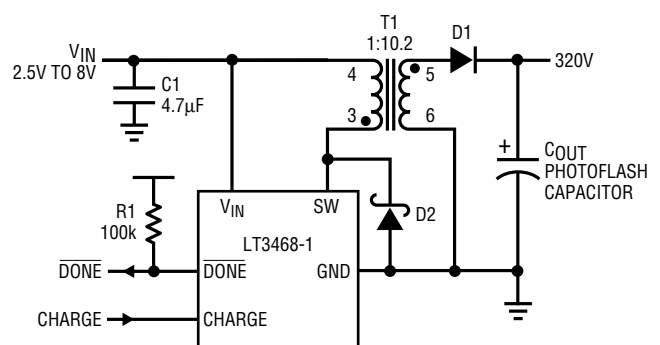

C1: 4.7μF, X5R OR X7R, 10V  
 T1: KIJIMA MUSEN PART# SBL-5.6S-1, L<sub>PR1</sub> = 24μH, N = 10.2  
 D1: VISHAY GSD2004S DUAL DIODE CONNECTED IN SERIES  
 D2: ZETEX ZHCS400 OR EQUIVALENT  
 R1: PULL UP RESISTOR NEEDED IF DONE PIN USED

**Figure 2. LT3468-1 Photoflash Charger Uses High Efficiency 3mm Tall Transformer**

# LT3468/LT3468-1

## ABSOLUTE MAXIMUM RATINGS

(Note 1)

$V_{IN}$ Voltage .....	16V
SW Voltage .....	-0.4V to 50V
CHARGE Voltage .....	10V
DONE Voltage .....	10V
Current into $\overline{DONE}$ Pin .....	$\pm 1$ mA
Maximum Junction Temperature .....	125°C
Operating Temperature Range (Note 2) ...	-40°C to 85°C
Storage Temperature Range .....	-65°C to 150°C
Lead Temperature (Soldering, 10 sec) .....	300°C

## PACKAGE/ORDER INFORMATION

<p>TOP VIEW</p> <p>SW 1    5 VIN</p> <p>GND 2</p> <p>DONE 3    4 CHARGE</p> <p>S5 PACKAGE 5-LEAD PLASTIC SOT-23 <math>T_{JMAX} = 125^{\circ}\text{C}</math>, <math>\theta_{JA} = 256^{\circ}\text{C/W}</math></p>	ORDER PART NUMBER
	LT3468ES5 LT3468ES5-1
	S5 PART MARKING
	LTAEC LTAGQ

Consult LTC Marketing for parts specified with wider operating temperature ranges.

## ELECTRICAL CHARACTERISTICS

The ● denotes the specifications which apply over the full operating temperature range, otherwise specifications are at  $T_A = 25^{\circ}\text{C}$ .  $V_{IN} = 3\text{V}$ ,  $V_{CHARGE} = V_{IN}$  unless otherwise noted. (Note 2) Specifications are for both the LT3468 and LT3468-1 unless otherwise noted.

PARAMETER	CONDITIONS	MIN	TYP	MAX	UNITS
Quiescent Current	Not Switching $V_{CHARGE} = 0\text{V}$		5 0	8 1	mA $\mu\text{A}$
Input Voltage Range		● 2.5		16	V
Switch Current Limit	LT3468 (Note 3) LT3468-1	1.1 0.45	1.2 0.55	1.3 0.65	A A
Switch $V_{CESAT}$	LT3468, $I_{SW} = 1\text{A}$ LT3468-1, $I_{SW} = 400\text{mA}$		330 150	430 200	mV mV
$V_{OUT}$ Comparator Trip Voltage	Measured as $V_{SW} - V_{IN}$	● 31	31.5	32	V
$V_{OUT}$ Comparator Overdrive	300ns Pulse Width		200	400	mV
DCM Comparator Trip Voltage	Measured as $V_{SW} - V_{IN}$	● 10	36	80	mV
CHARGE Pin Current	$V_{CHARGE} = 3\text{V}$ $V_{CHARGE} = 0\text{V}$		15 0	40 0.1	$\mu\text{A}$ $\mu\text{A}$
Switch Leakage Current	$V_{IN} = V_{SW} = 5\text{V}$ , in Shutdown	●	0.01	1	$\mu\text{A}$
CHARGE Input Voltage High		● 1			V
CHARGE Input Voltage Low		●		0.3	V
$\overline{DONE}$ Output Signal High	100k $\Omega$ from $V_{IN}$ to $\overline{DONE}$		3		V
$\overline{DONE}$ Output Signal Low	33 $\mu\text{A}$ into $\overline{DONE}$ Pin		100	200	mV
$\overline{DONE}$ Leakage Current	$V_{\overline{DONE}} = 3\text{V}$ , $\overline{DONE}$ NPN Off		20	100	nA

**Note 1:** Absolute Maximum Ratings are those values beyond which the life of a device may be impaired.

**Note 2:** The LT3468E/LT3468E-1 are guaranteed to meet performance specifications from 0°C to 70°C. Specifications over the -40°C to 85°C

operating temperature range are assured by design, characterization and correlation with statistical process.

**Note 3:** Specifications are for static test. Current limit in actual application will be slightly higher.

**TYPICAL PERFORMANCE CHARACTERISTICS** LT3468 curves use the circuit of Figure 1 and LT3468-1 curves use the circuit of Figure 2 unless otherwise noted.

**LT3468 Charging Waveform**

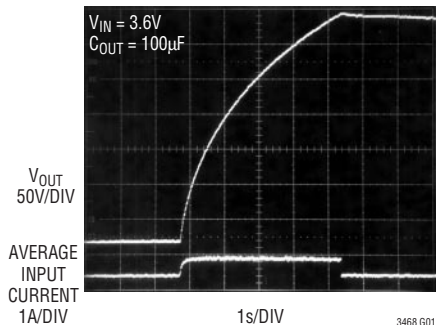

**LT3468-1 Charging Waveform**

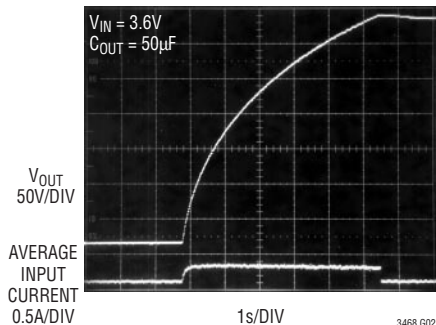

**LT3468 Charge Time**

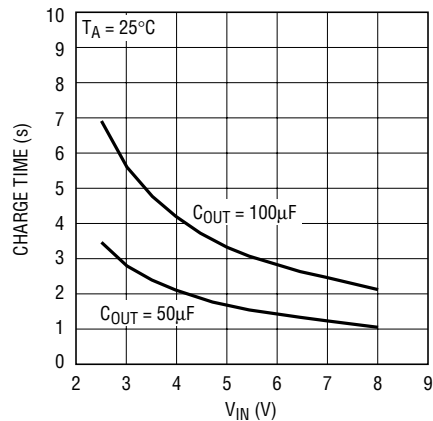

**LT3468-1 Charge Time**

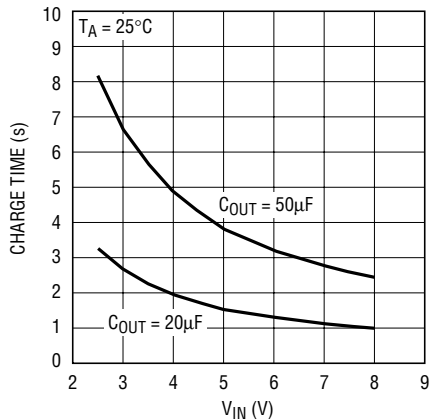

**LT3468 Input Current**

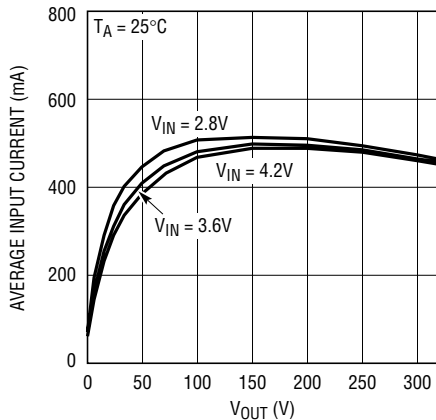

**LT3468-1 Input Current**

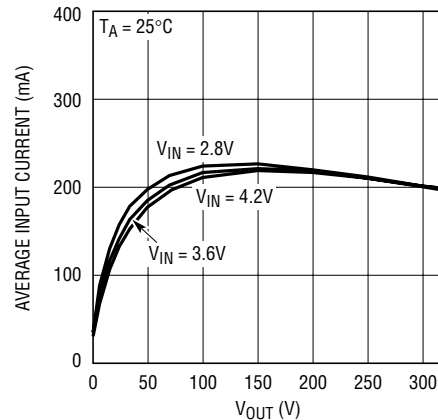

**LT3468 Efficiency**

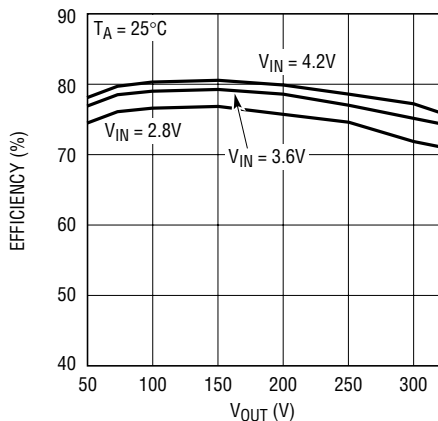

**LT3468-1 Efficiency**

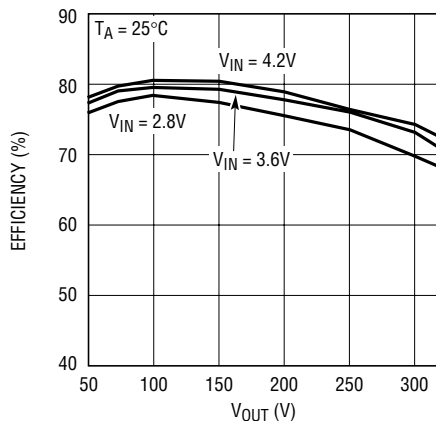

# LT3468/LT3468-1

## TYPICAL PERFORMANCE CHARACTERISTICS

LT3468 curves use the circuit of Figure 1 and LT3468-1 curves use the circuit of Figure 2 unless otherwise noted.

LT3468 Output Voltage

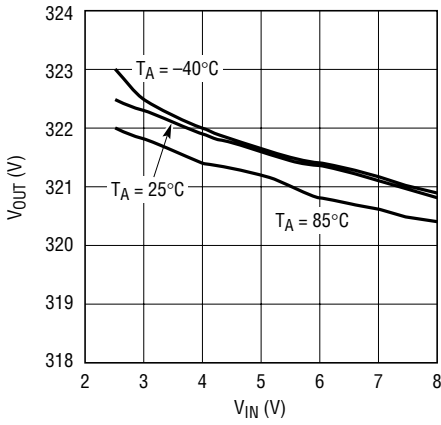

3468 G09

LT3468-1 Output Voltage

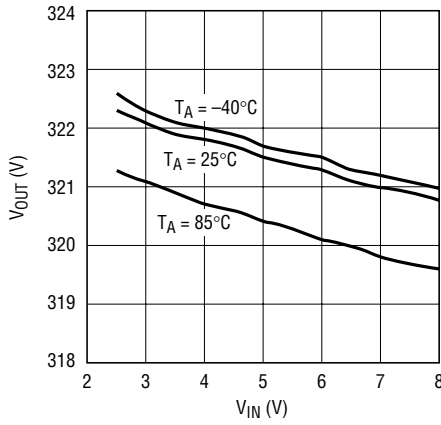

3468 G10

LT3468 Switch Current Limit

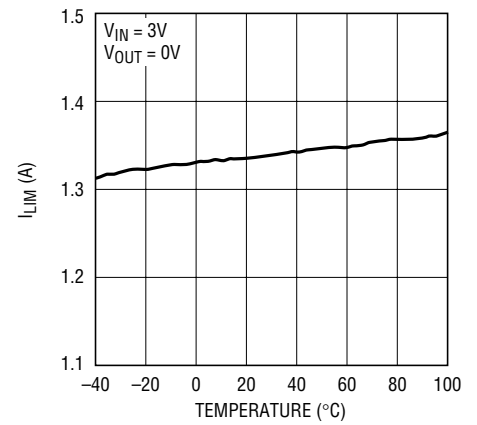

3468 G11

LT3468-1 Switch Current Limit

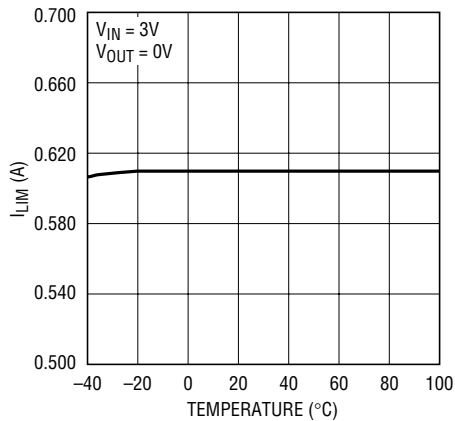

3468 G12

LT3468 Switching Waveform

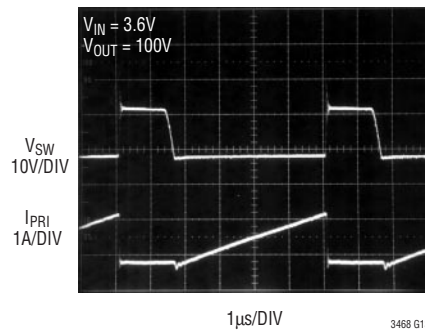

3468 G13

LT3468 Switching Waveform

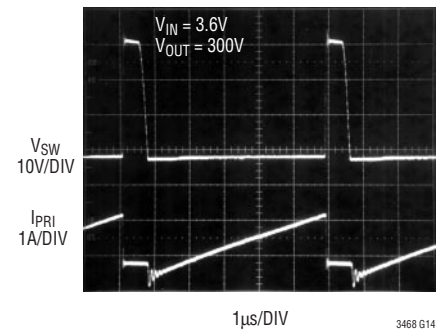

3468 G14

LT3468-1 Switching Waveform

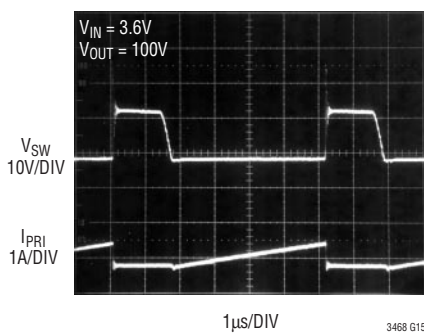

3468 G15

LT3468-1 Switching Waveform

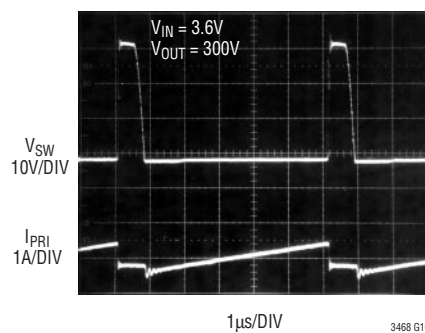

3468 G16

LT3468/LT3468-1 Switch Breakdown Voltage

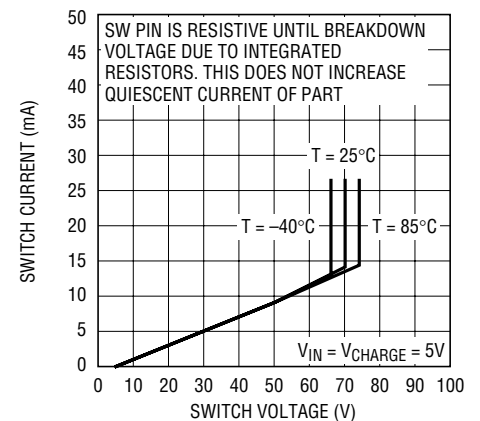

3468 G17

## PIN FUNCTIONS

**SW (Pin 1):** Switch Pin. This is the collector of the internal NPN Power switch. Minimize the metal trace area connected to this pin to minimize EMI. Tie one side of the primary of the transformer to this pin. The target output voltage is set by the turns ratio of the transformer.

Choose Turns Ratio N by the following equation:

$$N = \frac{V_{OUT} + 2}{31.5}$$

Where:  $V_{OUT}$  is the desired output voltage.

*You must tie a Schottky diode from GND to SW, with the anode at GND for proper operation of the circuit. Please refer to the applications section for further information.*

**GND (Pin 2):** Ground. Tie directly to local ground plane.

**DONE (Pin 3):** Open NPN Collector Indication Pin. When target output voltage is reached, NPN turns on. This pin needs a pull-up resistor or current source.

**CHARGE (Pin 4):** Charge Pin. A low (<0.3V) to high (>1V) transition on this pin puts the part into power delivery mode. Once the target output voltage is reached, the part will stop charging the output. Toggle this pin to start charging again. Ground to shut down.

**V<sub>IN</sub> (Pin 5):** Input Supply Pin. Must be locally bypassed with a good quality ceramic capacitor. Input supply must be 2.5V or higher.

**BLOCK DIAGRAM**

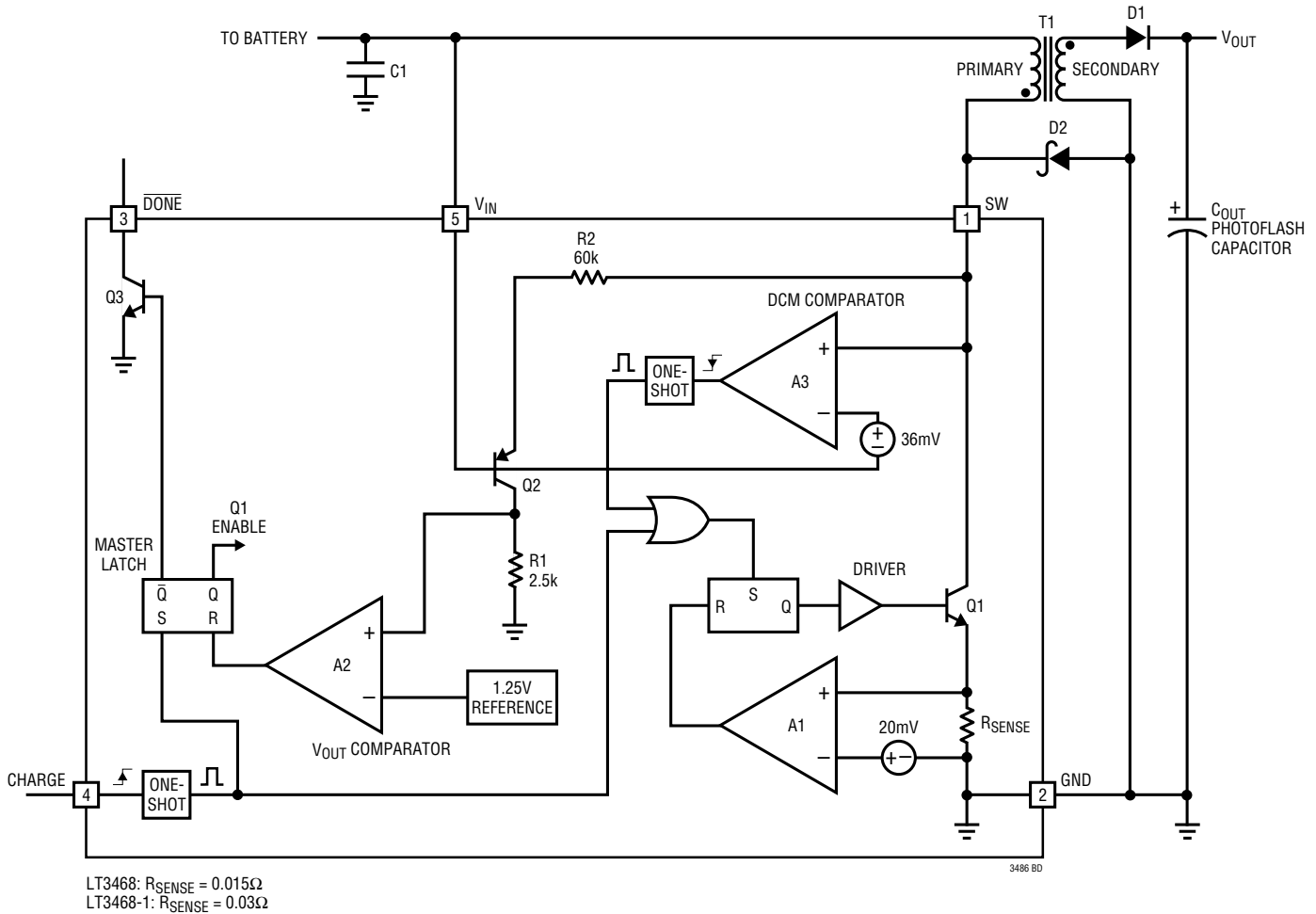

Figure 3

**OPERATION**

The LT3468/LT3468-1 are designed to charge photoflash capacitors quickly and efficiently. The operation of the part can be best understood by referring to Figure 3. When the CHARGE pin is first driven high, a one shot sets both SR latches in the correct state. The power NPN device, Q1, turns on and current begins ramping up in the primary of transformer T1. Comparator A1 monitors the switch current and when the peak current reaches 1.4A (LT3468) or 0.7A (LT3468-1), Q1 is turned off. Since T1 is utilized as a flyback transformer, the flyback pulse on the SW pin will cause the output of A3 to be high. The voltage on the SW pin needs to be at least 36mV higher than  $V_{IN}$  for this to happen.

During this phase, current is delivered to the photoflash capacitor via the secondary and diode D1. As the secondary current decreases to zero, the SW pin voltage will begin to collapse. When the SW pin voltage drops to 36mV above  $V_{IN}$  or lower, the output of A3 (DCM Comparator) will go low. This fires a one shot which turns Q1 back on. This cycle will continue to deliver power to the output.

Output voltage detection is accomplished via R2, R1, Q2, and comparator A2 ( $V_{OUT}$  Comparator). Resistors R1 and R2 are sized so that when the SW voltage is 31.5V above  $V_{IN}$ , the output of A2 goes high which resets the master latch. This disables Q1 and halts power delivery. Power delivery can only be restarted by toggling the CHARGE Pin.

## APPLICATIONS INFORMATION

### Choosing The Right Device (LT3468/LT3468-1)

The only difference between the two versions of the LT3468 is the peak current level. For the fastest possible charge time, use the LT3468. The LT3468-1 has a lower peak current capability, and is designed for applications that need a more limited drain on the batteries. Due to the lower peak current, the LT3468-1 can use a physically smaller transformer.

### Transformer Design

The flyback transformer is a key element for any LT3468/LT3468-1 design. It must be designed carefully and checked that it does not cause excessive current or voltage on any pin of the part. The main parameters that need to be designed are shown in Table 1.

The first transformer parameter that needs to be set is the turns ratio N. The LT3468/LT3468-1 accomplish output voltage detection by monitoring the flyback waveform on the SW pin. When the SW voltage reaches 31.5V higher than the  $V_{IN}$  voltage, the part will halt power delivery. Thus, the choice of N sets the target output voltage as it changes

the amplitude of the reflected voltage from the output to the SW pin. Choose N according to the following equation:

$$N = \frac{V_{OUT} + 2}{31.5}$$

Where:  $V_{OUT}$  is the desired output voltage. The number 2 in the numerator is used to include the effect of the voltage drop across the output diode(s).

Thus for a 320V output, N should be  $322/31.5$  or 10.2. For a 300V output, choose N equal to  $302/31.5$  or 9.6.

The next parameter that needs to be set is the primary inductance,  $L_{PRI}$ . Choose  $L_{PRI}$  according to the following formula:

$$L_{PRI} \geq \frac{V_{OUT} \cdot 200 \cdot 10^{-9}}{N \cdot I_{PK}}$$

Where:  $V_{OUT}$  is the desired output voltage. N is the transformer turns ratio.  $I_{PK}$  is 1.4 (LT3468), 0.7 (LT3468-1)

$L_{PRI}$  needs to be equal or larger than this value to ensure that the LT3468/LT3468-1 has adequate time to respond to the flyback waveform.

Table 1. Recommended Transformer Parameters

PARAMETER	NAME	TYPICAL RANGE LT3468	TYPICAL RANGE LT3468-1	UNITS
$L_{PRI}$	Primary Inductance	>5	>10	$\mu$ H
$L_{LEAK}$	Primary Leakage Inductance	100 to 300	200 to 500	nH
N	Secondary: Primary Turns Ratio	8 to 12	8 to 12	
$V_{ISO}$	Secondary to Primary Isolation Voltage	>500	>500	V
$I_{SAT}$	Primary Saturation Current	>1.6	>0.8	A
$R_{PRI}$	Primary Winding Resistance	<300	<500	m $\Omega$
$R_{SEC}$	Secondary Winding Resistance	<40	<80	$\Omega$



## APPLICATIONS INFORMATION

All other parameters need to meet or exceed the recommended limits as shown in Table 1. A particularly important parameter is the leakage inductance,  $L_{LEAK}$ . When the power switch of the LT3468/LT3468-1 turns off, the leakage inductance on the primary of the transformer causes a voltage spike to occur on the SW pin. The height of this spike must not exceed 40V, even though the absolute maximum rating of the SW Pin is 50V. The 50V absolute maximum rating is a DC blocking voltage specification, which assumes that the current in the power NPN is zero. Figure 4 shows the SW voltage waveform for the circuit of Figure 1 (LT3468). Note that the absolute maximum rating of the SW pin is not exceeded. Figure 5 shows the SW voltage waveform for the circuit of Figure 2 (LT3468-1). Again, the absolute maximum rating of the SW pin is

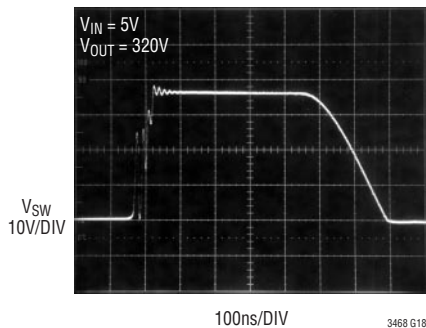

Figure 4. LT3468 SW Voltage Waveform

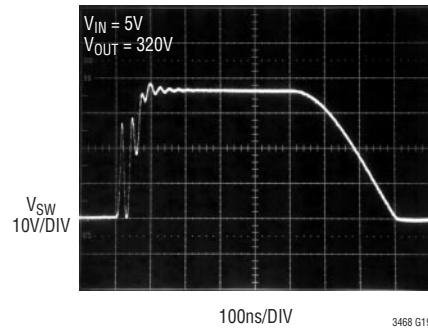

Figure 5. LT3468-1 SW Voltage Waveform

not compromised. Make sure to check the SW voltage waveform with  $V_{OUT}$  near the target output voltage, as this is the worst case condition for SW voltage.

It is important not to minimize the leakage inductance to a very low level. Although this would result in a very low leakage spike on the SW pin, the parasitic capacitance of the transformer would become large. This will adversely affect the charge time of the photoflash circuit.

Linear Technology has worked with several leading magnetic component manufacturers to produce pre-designed flyback transformers for use with the LT3468/LT3468-1. Table 2 shows the details of several of these transformers.

Table 2. Pre-Designed Transformers - Typical Specifications Unless Otherwise Noted.

FOR USE WITH	TRANSFORMER NAME	SIZE (W × L × H) mm	L <sub>PRI</sub> (μH)	LPRI-LEAKAGE (nH)	N	R <sub>PRI</sub> (mΩ)	R <sub>SEC</sub> (Ω)	VENDOR
LT3468 LT3468-1	SBL-5.6-1 SBL-5.6S-1	5.6 × 8.5 × 4.0 5.6 × 8.5 × 3.0	10 24	200 Max 400 Max	10.2 10.2	103 305	26 55	Kijima Musen Hong Kong Office 852-2489-8266 (ph) kijimahk@netvigator.com (email)
LT3468 LT3468-1	LDT565630T-001 LDT565630T-002	5.8 × 5.8 × 3.0 5.8 × 5.8 × 3.0	6 14.5	200 Max 500 Max	10.4 10.2	100 Max 240 Max	10 Max 16.5 Max	TDK Chicago Sales Office (847) 803-6100 (ph) www.components.tdk.com
LT3468/LT3468-1 LT3468-1	T-15-089 T-15-083	6.4 × 7.7 × 4.0 8.0 × 8.9 × 2.0	12 20	400 Max 500 Max	10.2 10.2	211 Max 675 Max	27 Max 35 Max	Tokyo Coil Engineering Japan Office 0426-56-6336 (ph) www.tokyo-coil.co.jp



## APPLICATIONS INFORMATION

### Capacitor Selection

For the input bypass capacitor, a high quality X5R or X7R type should be used. Make sure the voltage capability of the part is adequate.

### Output Diode Selection

The rectifying diode(s) should be low capacitance type with sufficient reverse voltage and forward current ratings. The peak reverse voltage that the diode(s) will see is approximately:

$$V_{PK-R} = V_{OUT} + (N \cdot V_{IN})$$

The peak current of the diode is simply:

$$I_{PK-SEC} = \frac{1.4}{N} \text{ (LT3468)}$$

$$I_{PK-SEC} = \frac{0.7}{N} \text{ (LT3468-1)}$$

For the circuit of Figure 1 with  $V_{IN}$  of 5V,  $V_{PK-R}$  is 371V and  $I_{PK-SEC}$  is 137mA. The GSD2004S dual silicon diode is recommended for most LT3468/LT3468-1 applications. Another option is to use the BAV23S dual silicon diodes. Toshiba makes a dual diode named 1SS306 which also meets all the requirements. Table 3 shows the various diodes and relevant specifications. Use the appropriate number of diodes to achieve the necessary reverse breakdown voltage.

### SW Pin Clamp Diode Selection

The diode D2 in Figure 1 is needed to clamp the SW node. Due to the new control scheme of the LT3468/LT3468-1, the SW node may go below ground during a switch cycle. The clamp diode prevents the SW node from going too far below ground. The diode is required for proper operation of the circuit. The recommended diode should be a Schottky diode with at least a 500mA peak forward current capability. Reverse voltage rating should be 40V or higher. Table 4 shows various recommended clamping diodes.

Table 3. Recommended Output Diodes

PART	MAX REVERSE VOLTAGE (V)	MAX FORWARD CONTINUOUS CURRENT (mA)	CAPACITANCE (pF)	VENDOR
GSD2004S (Dual Diode)	2x300	225	5	Vishay (402) 563-6866 www.vishay.com
BAV23S (Dual Diode)	2x250	225	5	Philips Semiconductor (800) 234-7381 www.philips.com
1SS306 (Dual Diode)	2x250	100	3	Toshiba (949) 455-2000 www.semicon.toshiba.co.jp

Table 4. Recommended Clamp Diodes

PART	MAX REVERSE VOLTAGE (V)	VENDOR
ZHCS400	40	Zetex (631) 360-2222 www.zetex.com
B0540W	40	Diodes Inc. (805) 446-4800 www.diodes.com

## APPLICATIONS INFORMATION

### Board Layout

The high voltage operation of the LT3468/LT3468-1 demands careful attention to board layout. You will not get advertised performance with careless layout. Figure 6 shows the recommended component placement. Keep the area for the high voltage end of the secondary as small as possible. Also note the larger than minimum spacing for

all high voltage nodes in order to meet breakdown voltage requirements for the circuit board. *It is imperative to keep the electrical path formed by C1, the primary of T1, and the LT3468/LT3468-1 as short as possible.* If this path is haphazardly made long, it will effectively increase the leakage inductance of T1, which may result in an overvoltage condition on the SW pin.

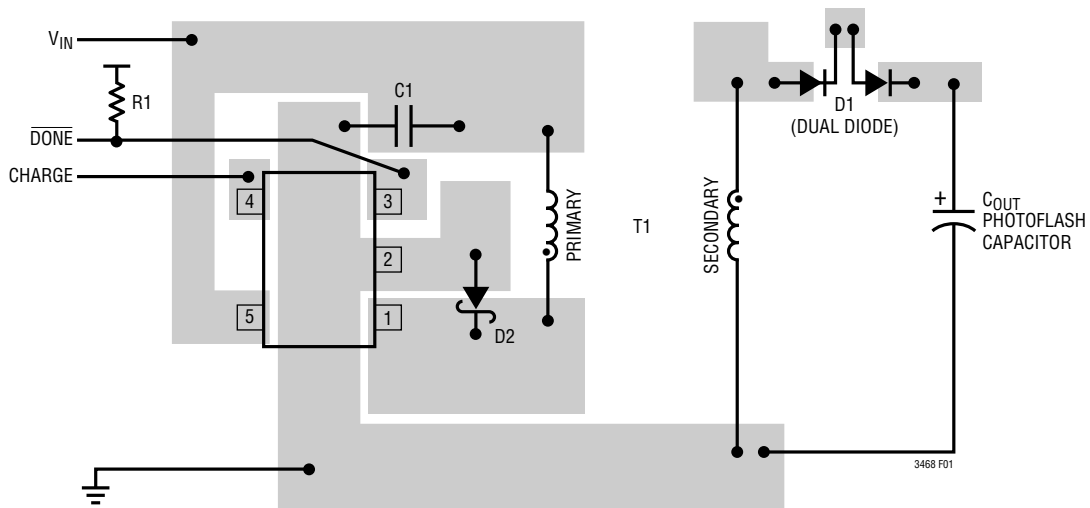
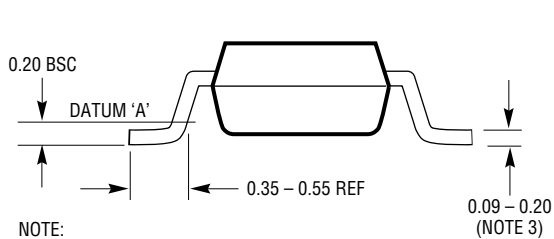
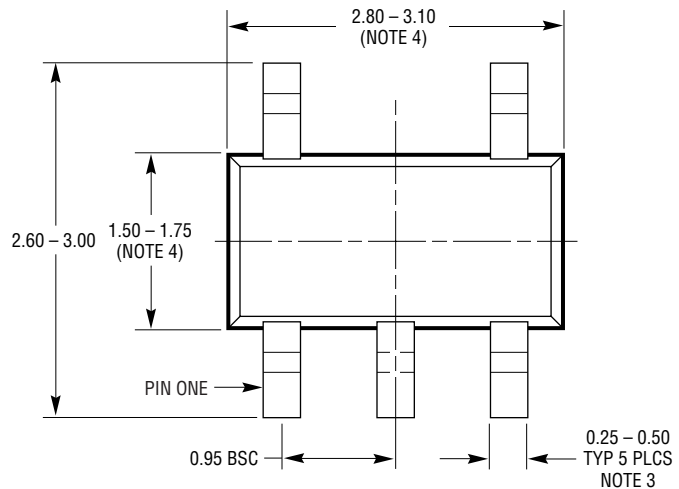
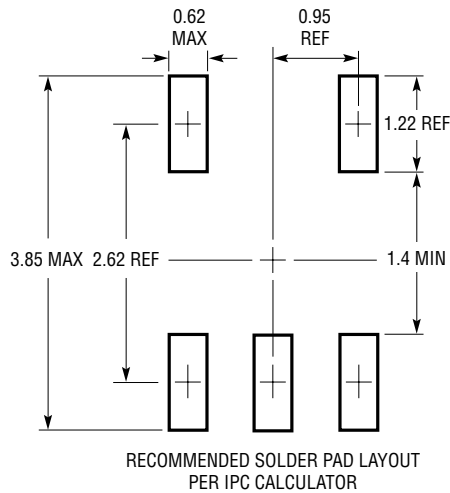

Figure 6. Suggested Layout: Keep electrical path formed by C1, Transformer Primary and LT3468/LT3468-1 short.

# PACKAGE DESCRIPTION

## S5 Package 5-Lead Plastic SOT-23 (Reference LTC DWG # 05-08-1633)



**NOTE:**

1. DIMENSIONS ARE IN MILLIMETERS
2. DRAWING NOT TO SCALE
3. DIMENSIONS ARE INCLUSIVE OF PLATING
4. DIMENSIONS ARE EXCLUSIVE OF MOLD FLASH AND METAL BURR
5. MOLD FLASH SHALL NOT EXCEED 0.254mm
6. PACKAGE EIAJ REFERENCE IS SC-74A (EIAJ)

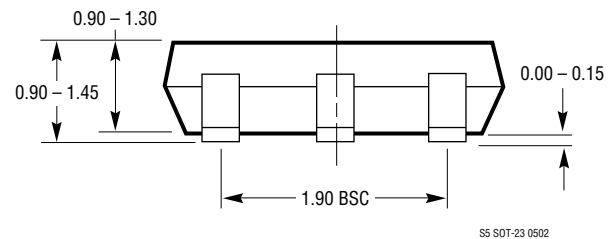

**ATTENTION: ORIGINAL SOT23-5L PACKAGE.**  
MOST SOT23-5L PRODUCTS CONVERTED TO THIN SOT23 PACKAGE, DRAWING # 05-08-1635 AFTER APPROXIMATELY APRIL 2001 SHIP DATE

# LT3468/LT3468-1

## TYPICAL APPLICATIONS

### LT3468 Photoflash Circuit uses Tiny 3mm Tall Transformer

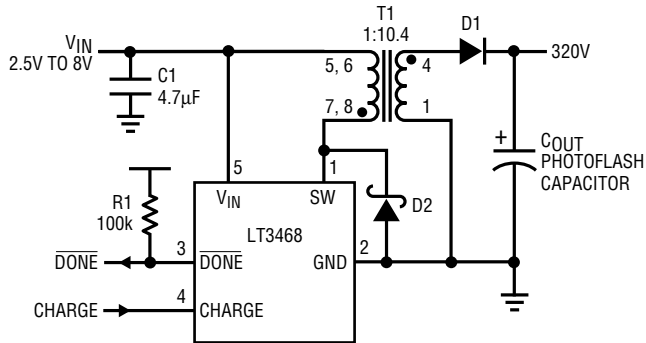

C1: 4.7µF, X5R OR X7R, 10V  
 T1: TDK PART# LDT565630T-001,  $L_{PRI} = 6\mu\text{H}$ ,  $N = 10.4$   
 D1: VISHAY GSD2004S DUAL DIODE CONNECTED IN SERIES  
 D2: ZETEX ZHCS400 OR EQUIVALENT  
 R1: PULL UP RESISTOR NEEDED IF DONE PIN USED

3468 TA03

### Charge Time

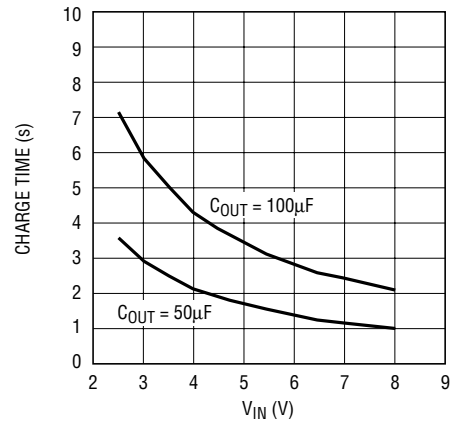

3468 TA05

### LT3468-1 Photoflash Circuit uses Tiny 3mm Tall Transformer

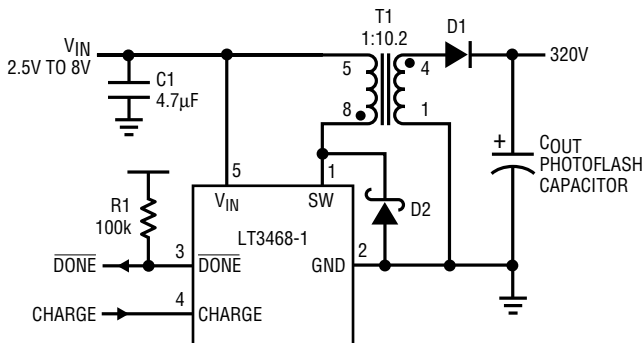

C1: 4.7µF, X5R OR X7R, 10V  
 T1: TDK PART# LDT565630T-002,  $L_{PRI} = 14.5\mu\text{H}$ ,  $N = 10.2$   
 D1: VISHAY GSD2004S DUAL DIODE CONNECTED IN SERIES  
 D2: ZETEX ZHCS400 OR EQUIVALENT  
 R1: PULL UP RESISTOR NEEDED IF DONE PIN USED

3468 TA04

### Charge Time

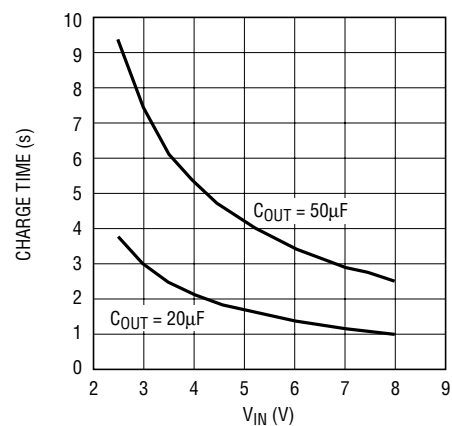

3468 TA06

## RELATED PARTS

PART NUMBER	DESCRIPTION	COMMENTS
LTC3407	Dual 600mA ( $I_{OUT}$ ), 1.5MHz, Synchronous Step-Down DC/DC Converter	96% Efficiency, $V_{IN}$ : 2.5V to 5.5V, $V_{OUT(MIN)}$ : 0.6V, $I_Q$ : 40µA, $I_{SD}$ : <1µA, MS10E
LT3420/LT3420-1	1.4A/1A, Photoflash Capacitor Chargers with Automatic Top-Off	Charges 220µF to 320V in 3.7 seconds from 5V, $V_{IN}$ : 2.2V to 16V, $I_Q$ : 90µA, $I_{SD}$ : <1µA, MS10
LTC3425	5A $I_{SW}$ , 8MHz, Multi-Phase Synchronous Step-Up DC/DC Converter	95% Efficiency, $V_{IN}$ : 0.5V to 4.5V, $V_{OUT(MIN)}$ : 5.25V, $I_Q$ : 12µA, $I_{SD}$ : <1µA, QFN-32
LTC3440/LTC3441	600mA/1A ( $I_{OUT}$ ), Synchronous Buck-Boost DC/DC Converter	95% Efficiency, $V_{IN}$ : 2.5V to 5.5V, $V_{OUT(MIN)}$ : 2.5V to 5.5V, $I_Q$ : 25µA, $I_{SD}$ : <1µA, MS-10, DFN-12

3468 1i