

SK-A29B0 Series



Size, mm

20 x 13

I/O

8 pin (14 pin) SMD Gull Wing

Supply Voltage

3.3V / 2.5V



For the most up to date specifications on each NEL product, log on to our website—www.nelfc.com

Differential Positive ECL (DPECL)

SK-A29B0 Series *Rev D*

Frequency Range: 350.0 MHz to 1.7 GHz

Description

The **SK-A29B0 Series** of quartz crystal oscillators provide DPECL Fast Edge compatible signals. This device is to operate using positive voltage and uses multiple ground pins for improved signal integrity. This device is intended to operate on positive voltage for PECL applications.

Features

- High Reliability - NEL HALT/HASS qualified for crystal oscillator start-up conditions
- Low jitter - Wavecrest jitter characterization available
- Wide frequency range—350.0 MHz to 1.7 GHz
- User specified tolerance available
- Case at electrical ground
- Will withstand SMD reflow temperatures of 253°C for 4 minutes maximum
- All metal, resistance weld, hermetically sealed package
- High shock resistance, to 1500g
- High Q Crystal actively tuned oscillator circuit
- Power supply decoupling internal
- High frequencies due to proprietary design
- RoHS compliant, lead free construction

Creating a Part Number

SK - A29BX - FREQ

Package Code

HK Leaded 8 pin (14 pin)

SK 8 pin (14 pin) SMD Gull Wing

Input Voltage

Code Specification

A 3.3 V

B 2.5 V

Tolerance/Performance

0 ±100 ppm 0-70°C

1 ±50 ppm 0-70°C

7 ±25 ppm 0-70°C

9 Customer Specific

A ±20 ppm 0-70°C

B ±50 ppm -40 to +85°C

C ±100 ppm -40 to +85°C

Drawing Specifications

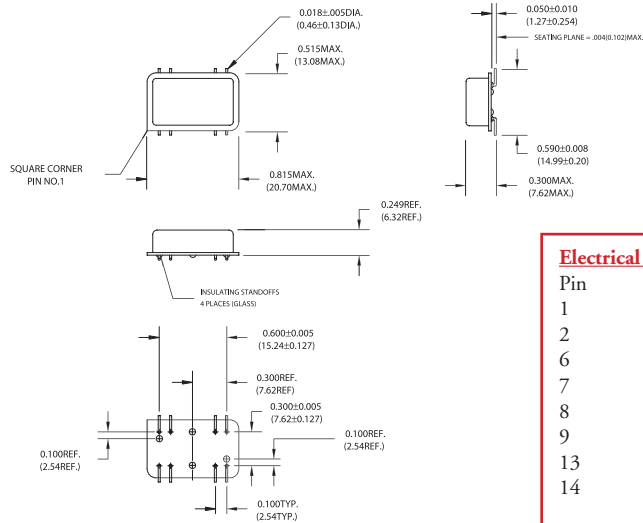

Electrical Connections

Pin	Connection
1	V _{CC}
2	V _{EE} Case
6	V _{EE} Case
7	Output
8	/Output
9	V _{EE} Case
13	V _{EE} Case
14	Enable/Disable

All other pins are no connect

Dimension shown in inches and (mm).

Differential Positive ECL (DPECL)

SK-A29B0 Series *Rev D*

Frequency Range: 350.0 MHz to 1.7 GHz

Operating Conditions and Output Characteristics

Electrical Characteristics

Parameter	Symbol	Conditions	Min	Typical	Max
Frequency	—	—	350.0 MHz	—	1.7 GHz
Duty Cycle	—	@50% points	45/55%	—	55/45%
Logic 0 ⁽¹⁾	V _{OL}	—	V _{CC} -1.810 V	—	V _{CC} -1.620 V
Logic 1 ⁽¹⁾	V _{OH}	—	V _{CC} -1.025 V	—	V _{CC} -0.880 V
Rise & Fall Time	t _r , t _f	20-80% V _O with 50 ohm load to V _{CC} -2V	—	350 psec	600 psec
Jitter, RMS ⁽⁴⁾	—	—	—	0.3 psec	0.5 psec
Enable Voltage ⁽²⁾	—	with V _{EE} = 0V	0 V	—	1.0 V
Disable Voltage	—	with V _{EE} = 0V	3.0 V	—	V _{CC}
Frequency Stability ⁽³⁾	dF/F	Overall conditions including: voltage, calibration, temp., 10 yr aging, shock, vibration	-100 ppm	—	+100 ppm

General Characteristics

Parameter	Symbol	Conditions	Min	Typical	Max
Supply Voltage	V _{CC}	3.3V±5%	3.135 V	3.3 V	3.465 V
Supply Current	I _{CC}	50 ohm termination To 2.00V below V _{CC}	0.0 mA	—	160 mA
Output Current	I _O	Low level Output Current	0.0 mA	—	±50.0 mA
Operating Temperature	T _A	—	0°C	—	70°C
Storage Temperature	T _S	—	-55°C	—	125°C
Input: Logic High (ECL) - Disables V _{EE} or Open - Enables	—	—	—	—	—
Lead Temperature	T _L	Soldering, 10 sec.	—	—	300°C
Load	50 ohm to V _{CC} -2V or Thevenin Equivalent, Bias Required	—	—	—	—
Start-up Time	t _s	—	—	2 ms	10 ms

Environmental and Mechanical Characteristics

Mechanical Shock	Per MIL-STD-202, Method 213, Condition E
Thermal Shock	Per MIL-STD-833, Method 1011, Condition A
Vibration	0.060" double amplitude 10 Hz to 55 Hz, 35g's 55 Hz to 2000 Hz
Soldering Condition	300°C for 10 seconds
Hermetic Seal	Leak rate less than 1 x 10 ⁻⁸ atm.cc/sec of helium

Footnotes:

- 1) V_{OL}, V_{OH}, referenced to ground.
- 2) Open to Enable pin also enables the output.
- 3) Standard frequency stability (others available).
- 4) Jitter performance is frequency dependent. Please contact factory for full Aeroflex characterization. RMS jitter bandwidth of 12kHz to 20MHz.

Test Circuit

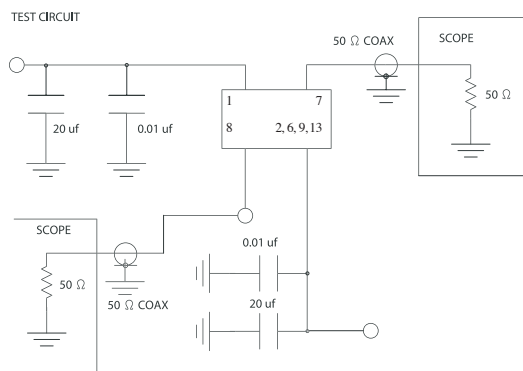

Test Circuit uses a split supply of +2V and -1.3V for ease of testing.