

M61545AFP

Serial Data Control Dual Electronic Volume

REJ03F0162-0200
Rev.2.0
Dec 21, 2005

Description

The M61545AFP is a dual channel electronic volume controlled with 2-wire serial data. The built-in reference and power regulator circuitries allow operation of an electronic volume with less external parts. M61545AFP is able to cater for large supply voltage range of 4.5 to 15.0V.

Features

- Electronic volume 0 to -95dB/ 1-dB step, -∞dB
2-ch independent controllable electronic volume
- Low distortion THD = 0.002% typ.
Vno = 5.0μVrms typ. (ATT = -∞, JIS-A network)
- Supply voltage range Single power supply: Vcc = 4.5 to 15V (regulated)
Supply to both digital & analog circuitries
- Serial data interface 2-wire type
- Package 8 pin SOP/ 8 pin DIP
- Process 0.5μ BIC-DMOS
- Reference circuit Built-in

Recommended Operating Condition

- Supply voltage range: Vcc = 4.5 to 15.0V

Pin Configuration

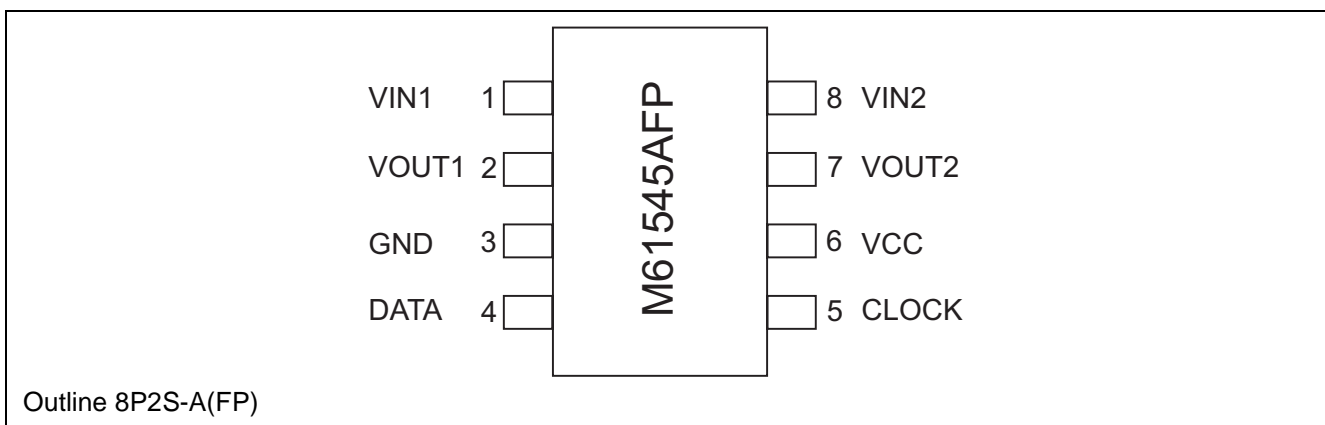

IC Internal Block Diagram

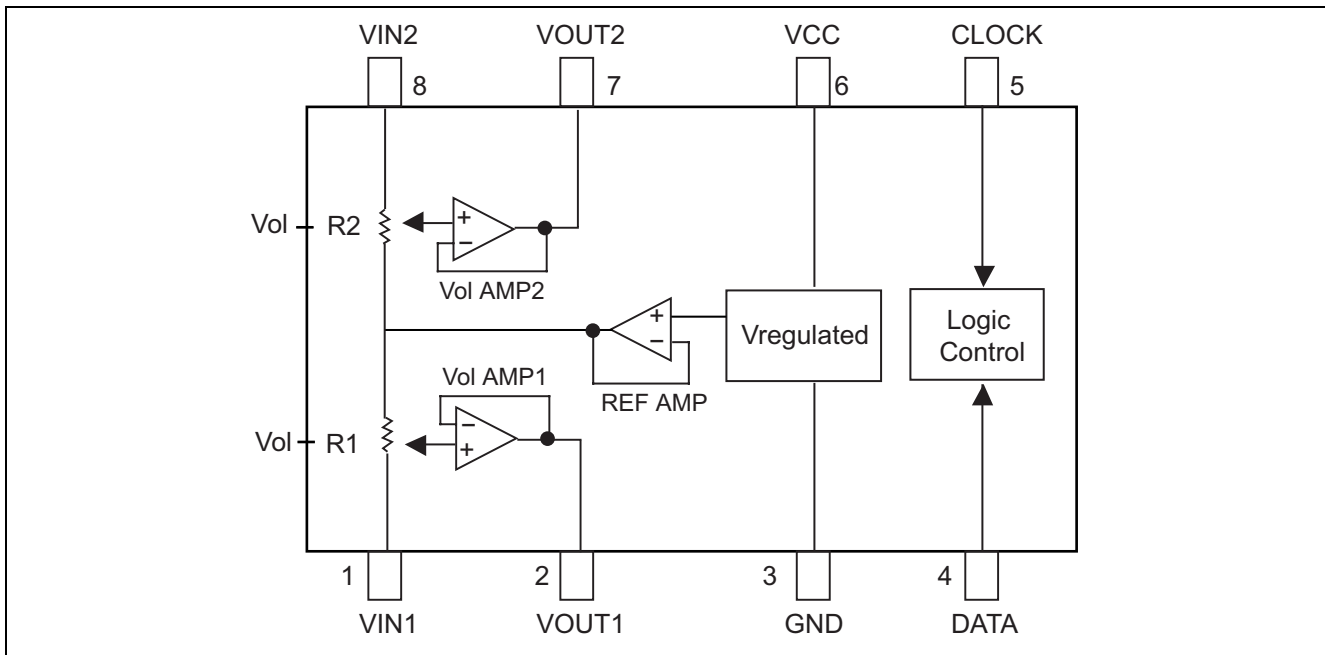

Pin Description

Pin	Symbol	Function
1	VIN1	1-ch input pin
2	VOUT1	1-ch output pin
3	GND	Ground pin
4	DATA	Control data input pin. Inputs data in synchronization with clock
5	CLOCK	Clock input pin for transferring serial data
6	VCC	Power supply pin. Stabilize the pin with decoupling capacitor
7	VOUT2	2-ch output pin
8	VIN2	2-ch input pin

Absolute Maximum Ratings

Parameter	Symbol	Ratings	Units
Supply voltage	Vcc, Vdd	16.0	V
Power dissipation	Pd	385 ^{*1}	mW
Operating temperature	Topr	-40 to +85	°C
Storage temperature	Tstg	-55 to +125	°C

Note: *1. These are the allowable values up to $T_a = 31^\circ\text{C}$ mounting on 30% wiring density glass epoxy board.
Derate by 7.14mW/°C above that temperature.

Electrical Characteristics

(V_{CC} = 14.0V, T_a = 25°C, unless stated otherwise)

Parameter	Symbol	Limits			Unit	Test Conditions
		Min	Typ	Max		
Circuit current	I _{CC}		8	10	mA	
Maximum attenuation	A _{TT}	—	-90	-80	dB	A _{TT} = -∞
Attenuation error	ΔA _{TT}	-2.0	0	2.0	dB	A _{TT} = 0dB
Maximum input voltage	V _{IM}	—	5.4	—	V _{rms}	THD = 1%, A _{TT} = -6dB
Maximum output voltage	V _{OM}	3.8	4.2	—	V _{rms}	THD = 1%, A _{TT} = 0dB
Output noise voltage	V _{NO1}	—	1.5	5.0	μV _{rms}	A _{TT} = 0dB, R _g = 0, JIS-A
	V _{NO2}	—	7.0	12.0	μV _{rms}	A _{TT} = -∞, R _g = 0, JIS-A
Total harmonic distortion	THD	—	0.002	0.009	%	F = 1kHz, V _o = 0.5V _{rms} , A _{TT} = 0dB
Channel separation	CS	—	-80	-70	dB	F = 1kHz, JIS-A, A _{TT} = 0dB

Electrical Characteristics

(V_{CC} = 10.0V, T_a = 25°C, unless stated otherwise)

Parameter	Symbol	Limits			Unit	Test Conditions
		Min	Typ	Max		
Circuit current	I _{CC}		NA	10	mA	
Maximum attenuation	A _{TT}	—	-90	-80	dB	A _{TT} = -∞
Attenuation error	ΔA _{TT}	-2.0	0	2.0	dB	A _{TT} = 0dB
Maximum input voltage	V _{IM}	—	4.0	—	V _{rms}	THD = 1%, A _{TT} = -6dB
Maximum output voltage	V _{OM}	2.4	2.9	—	V _{rms}	THD = 1%, A _{TT} = 0dB
Output noise voltage	V _{NO1}	—	1.5	5.0	μV _{rms}	A _{TT} = 0dB, R _g = 0, JIS-A
	V _{NO2}	—	6.0	12.0	μV _{rms}	A _{TT} = -∞, R _g = 0, JIS-A
Total harmonic distortion	THD	—	0.002	0.009	%	F = 1kHz, V _o = 0.5V _{rms} , A _{TT} = 0dB
Channel separation	CS	—	-80	-70	dB	F = 1kHz, JIS-A, A _{TT} = 0dB

Electrical Characteristics

(V_{CC} = 7.0V, T_a = 25°C, unless stated otherwise)

Parameter	Symbol	Limits			Unit	Test Conditions
		Min	Typ	Max		
Circuit current	I _{CC}		NA	10	mA	
Maximum attenuation	A _{TT}	—	-90	-80	dB	A _{TT} = -∞
Attenuation error	ΔA _{TT}	-2.0	0	2.0	dB	A _{TT} = 0dB
Maximum input voltage	V _{IM}	—	2.9	—	V _{rms}	THD = 1%, A _{TT} = -6dB
Maximum output voltage	V _{OM}	1.3	1.8	—	V _{rms}	THD = 1%, A _{TT} = 0dB
Output noise voltage	V _{NO1}	—	1.5	5.0	μV _{rms}	A _{TT} = 0dB, R _g = 0, JIS-A
	V _{NO2}	—	5.0	12.0	μV _{rms}	A _{TT} = -∞, R _g = 0, JIS-A
Total harmonic distortion	THD	—	0.002	0.009	%	F = 1kHz, V _o = 0.5V _{rms} , A _{TT} = 0dB
Channel separation	CS	—	-80	-70	dB	F = 1kHz, JIS-A, A _{TT} = 0dB

Electrical Characteristics

($V_{CC} = 5.0V$, $T_a = 25^\circ C$, unless stated otherwise)

Parameter	Symbol	Limits			Unit	Test Conditions
		Min	Typ	Max		
Circuit current	I_{CC}		NA	10	mA	
Maximum attenuation	A_{TT}	—	-90	-80	dB	$A_{TT} = -\infty$
Attenuation error	ΔA_{TT}	-2.0	0	2.0	dB	$A_{TT} = 0dB$
Maximum input voltage	V_{IM}	—	2.0	—	V _{rms}	THD = 1%, $A_{TT} = -6dB$
Maximum output voltage	V_{OM}	0.5	1.1	—	V _{rms}	THD = 1%, $A_{TT} = 0dB$
Output noise voltage	V_{NO1}	—	1.5	5.0	μV_{rms}	$A_{TT} = 0dB$, $R_g = 0$, JIS-A
	V_{NO2}	—	5.0	12.0	μV_{rms}	$A_{TT} = -\infty$, $R_g = 0$, JIS-A
Total harmonic distortion	THD	—	0.01	0.05	%	$F = 1kHz$, $V_o = 0.1V_{rms}$, $A_{TT} = 0dB$
Channel separation	CS	—	-80	-70	dB	$F = 1kHz$, JIS-A, $A_{TT} = 0dB$

DC Characteristics of Digital Block

Parameter	Symbol	Limits			Unit	Test Conditions
		Min	Typ	Max		
"L" level input voltage	V_{IL}	0	—	0.6	V	Data, clock pin
"H" level input voltage	V_{IH}	2.2	—	—	V	
"L" level input current	I_{IL}	-10	—	10	μA	$V_i = 0$, Data, clock pin
"H" level input current	I_{IH}	—	—	10	μA	

AC Characteristics of Digital Block

Parameter	Symbol	Limits			Unit
		Min	Typ	Max	
CLOCK cycle time	t_{cr}	4	—	—	μsec
CLOCK pulse width ("H" level)	t_{WHC}	1.6	—	—	
CLOCK pulse width ("L" level)	t_{WLC}	1.6	—	—	
CLOCK rise time	t_r	—	—	0.4	
CLOCK fall time	t_f	—	—	0.4	
DATA setup time	t_{SD}	0.8	—	—	
DATA hold time	t_{HD}	0.8	—	—	

Clock and Data Timings (Recommended Conditions)

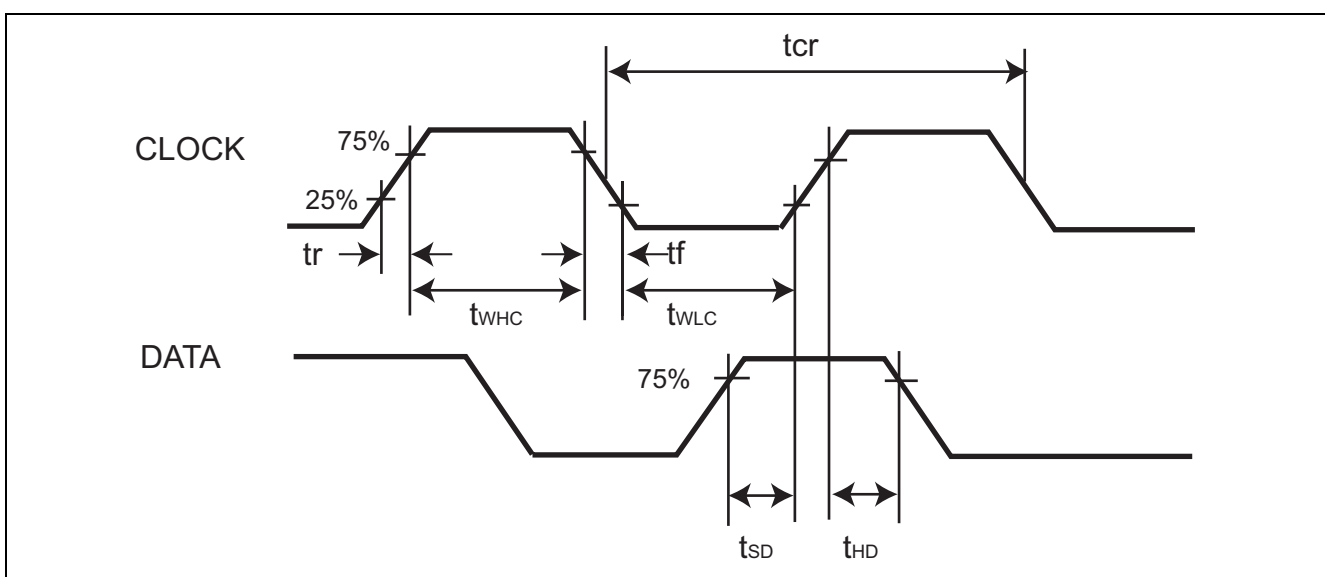

Relationship Between Data, Clock

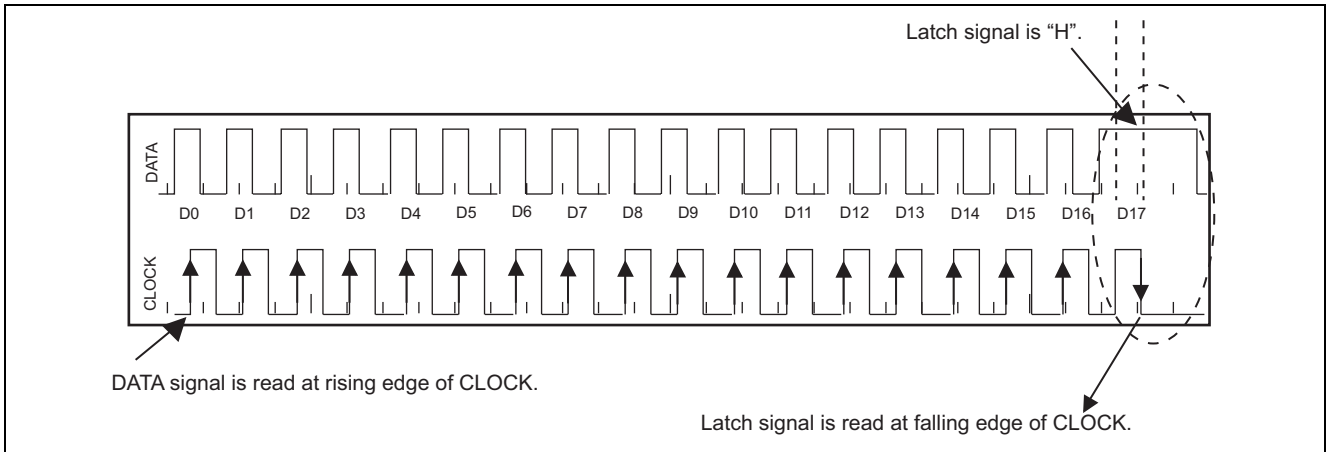

Data Format for "H" & "L"

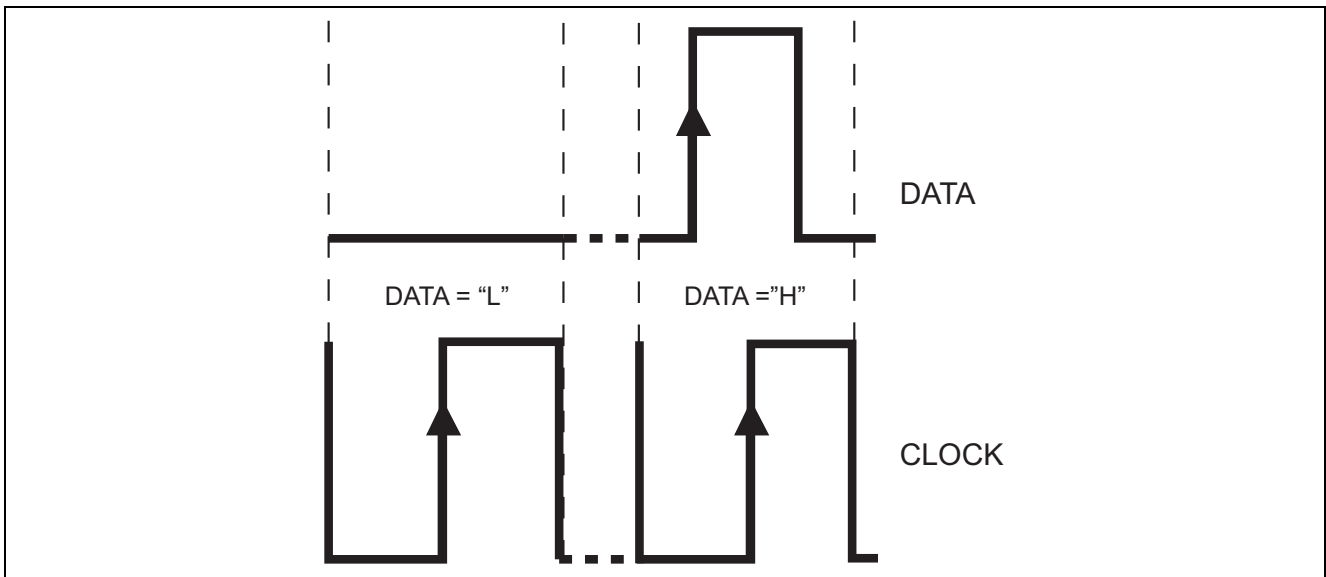

For initialization, 2 blocks of identical 18-bit data need to be sent. The 2 blocks of data would set the operation condition for M61545AFP. This shown in figure below,

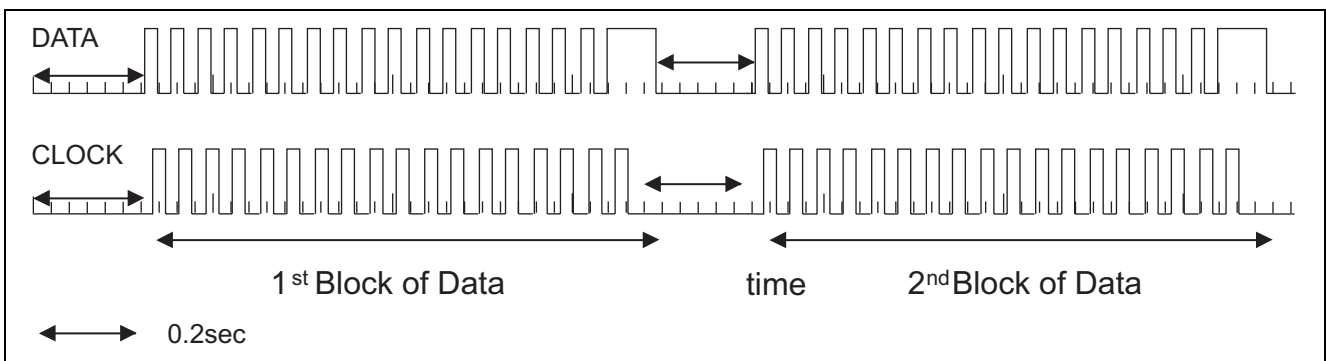

There should be a delay of 0.2 second before the first block of Clock and Data appear. The interval between the 1st Block of data and the 2nd Block should be 0.2 second as well. This sequence is to ensure proper operation of M61545AFP due to the wide dynamic voltage range, which M61545AFP is made to cater for.

This format of initialization needs to be done once only during every powering up of M61545AFP.

It recommends to use external mute switch together because it might generate the shock noise during this initial setup timing.

Initialization Examples

Example 1:

Setting supply of 9.0 to 12.0 V, and attenuation of -20dB (please refer to page 7 for data format)

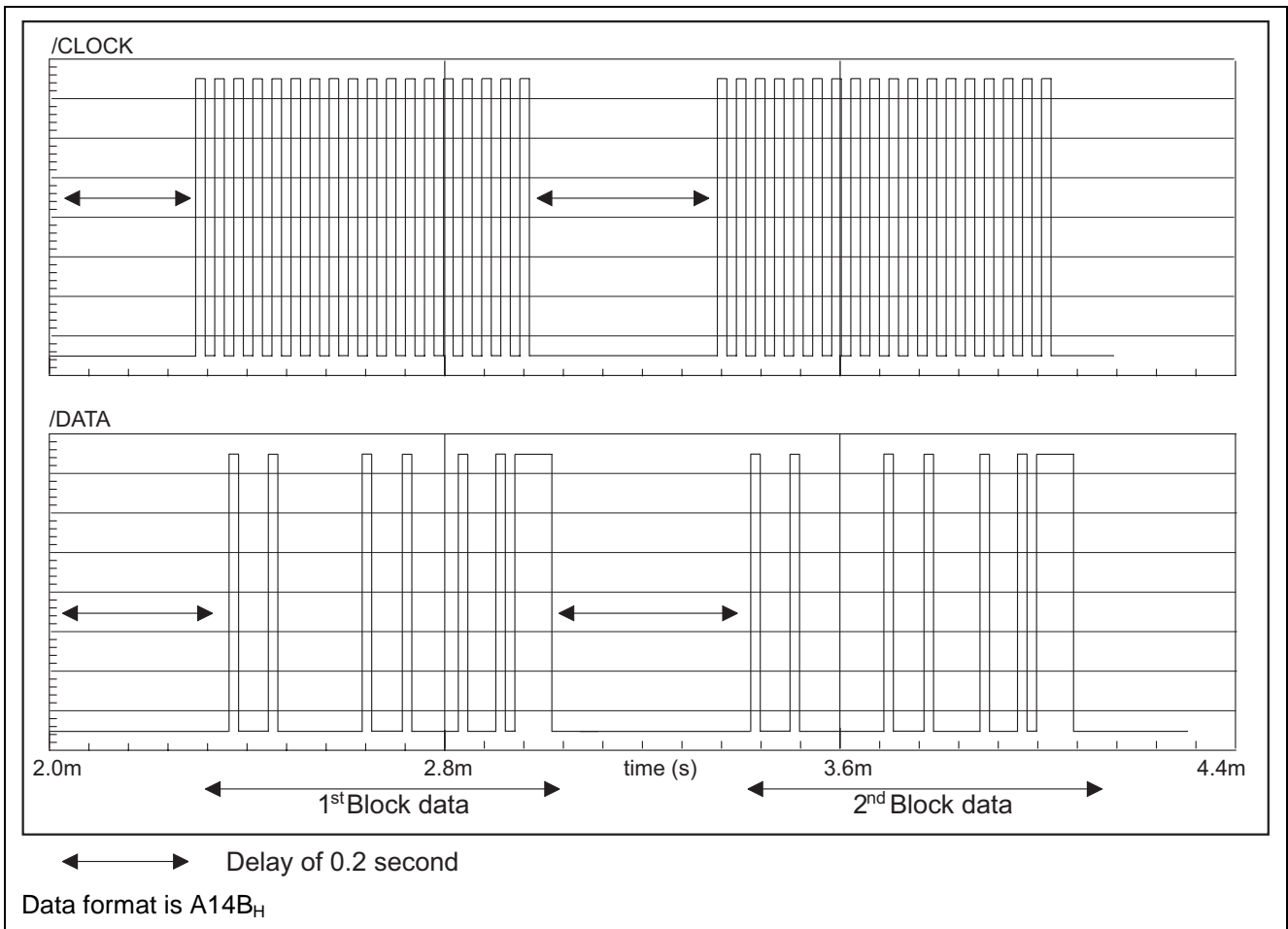

Example 2:
Setting supply of 4.5V to 6.0V, and attenuation of -90dB (please refer to data format below)

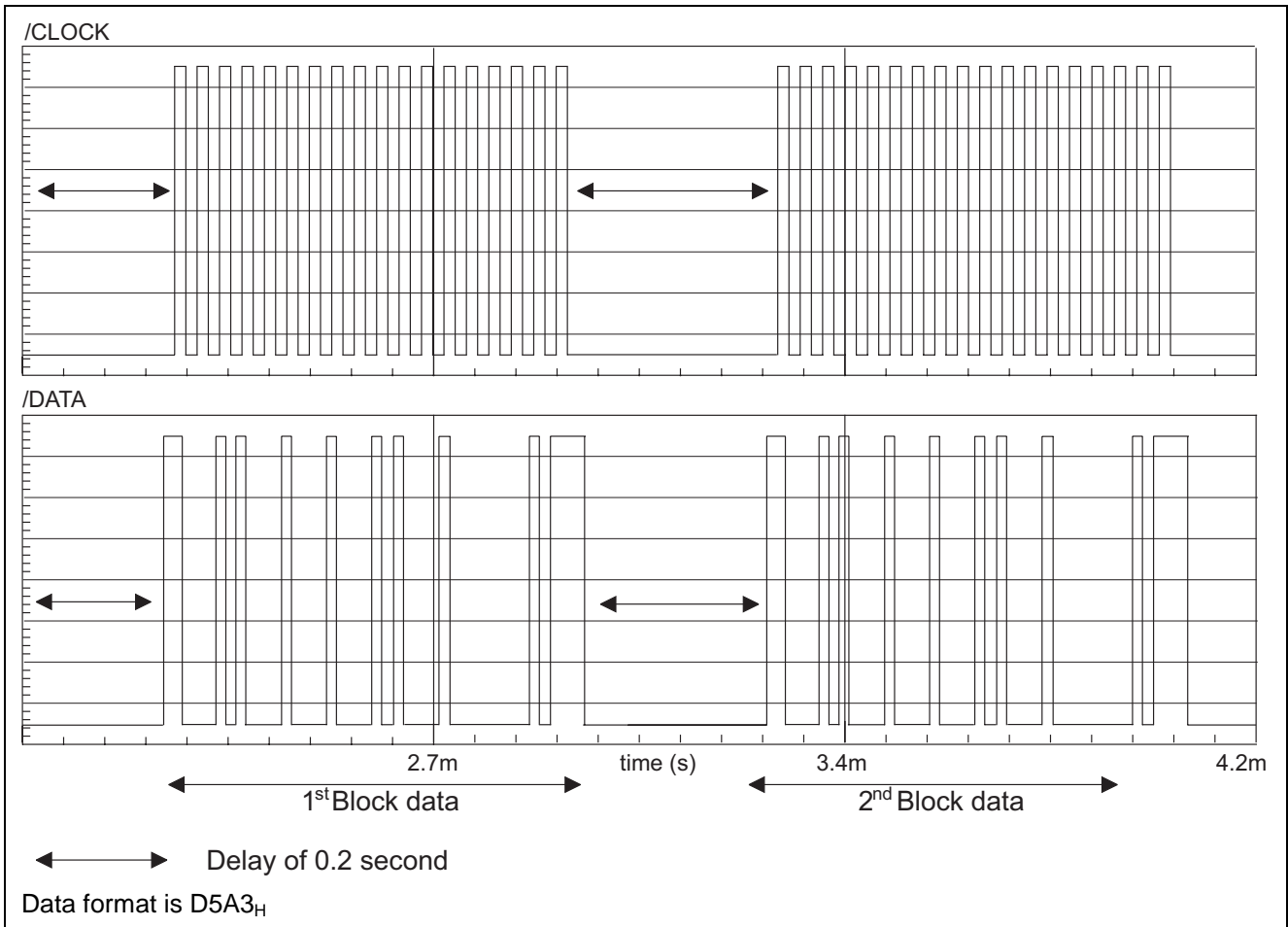

Data Input Format

D0	D1	D2	D3	D4	D5	D6	D7	D8	D9	D10	D11	D12	D13	D14	D15	D16	D17
Left Channel							Right Channel							DC Switch	1	1	

DC Switch

Supply Voltage (V)	D14	D15
12.0 to 15.0	1	1
9.0 to 12.0	1	0
6.0 to 9.0	0	1
4.5 to 6.0	0	0

Volume Code

ATT	D0	D1	D2	D3	D4	D5	D6	← Left Channel	← Right Channel
	D7	D8	D9	D10	D11	D12	D13		
0	L	L	L	L	L	L	L		
-1	L	L	L	L	L	L	H		
-2	L	L	L	L	L	H	L		
-3	L	L	L	L	L	H	H		
-4	L	L	L	L	H	L	L		
-5	L	L	L	L	H	L	H		
-6	L	L	L	L	H	H	L		
-7	L	L	L	L	H	H	H		
-8	L	L	L	H	L	L	L		
-9	L	L	L	H	L	L	H		
-10	L	L	L	H	L	H	L		
-11	L	L	L	H	L	H	H		
-12	L	L	L	H	H	L	L		
-13	L	L	L	H	H	L	H		
-14	L	L	L	H	H	H	L		
-15	L	L	L	H	H	H	H		
-16	L	L	H	L	L	L	L		
-17	L	L	H	L	L	L	H		
-18	L	L	H	L	L	H	L		
-19	L	L	H	L	L	H	H		
-20	L	L	H	L	H	L	L		
-21	L	L	H	L	H	L	H		
-22	L	L	H	L	H	H	L		
-23	L	L	H	L	H	H	H		
-24	L	L	H	H	L	L	L		
-25	L	L	H	H	L	L	H		
-26	L	L	H	H	L	H	L		
-27	L	L	H	H	L	H	H		
-28	L	L	H	H	H	L	L		
-29	L	L	H	H	H	L	H		
-30	L	L	H	H	H	H	L		
-31	L	L	H	H	H	H	H		
-32	L	H	L	L	L	L	L		
-33	L	H	L	L	L	L	H		
-34	L	H	L	L	L	H	L		
-35	L	H	L	L	L	H	H		
-36	L	H	L	L	H	L	L		
-37	L	H	L	L	H	L	H		
-38	L	H	L	L	H	H	L		
-39	L	H	L	L	H	H	H		
-40	L	H	L	H	L	L	L		
-41	L	H	L	H	L	L	H		
-42	L	H	L	H	L	H	L		
-43	L	H	L	H	L	H	H		
-44	L	H	L	H	H	L	L		
-45	L	H	L	H	H	L	H		
-46	L	H	L	H	H	H	L		
-47	L	H	L	H	H	H	H		
-48	L	H	H	L	L	L	L		
-49	L	H	H	L	L	L	H		

ATT	D0	D1	D2	D3	D4	D5	D6	← Left Channel ← Right Channel
	D7	D8	D9	D10	D11	D12	D13	
-50	L	H	H	L	L	H	L	
-51	L	H	H	L	L	H	H	
-52	L	H	H	L	H	L	L	
-53	L	H	H	L	H	L	H	
-54	L	H	H	L	H	H	L	
-55	L	H	H	L	H	H	H	
-56	L	H	H	H	L	L	L	
-57	L	H	H	H	L	L	H	
-58	L	H	H	H	L	H	L	
-59	L	H	H	H	L	H	H	
-60	L	H	H	H	H	L	L	
-61	L	H	H	H	H	L	H	
-62	L	H	H	H	H	H	L	
-63	L	H	H	H	H	H	H	
-64	H	L	L	L	L	L	L	
-65	H	L	L	L	L	L	H	
-66	H	L	L	L	L	H	L	
-67	H	L	L	L	L	H	H	
-68	H	L	L	L	H	L	L	
-69	H	L	L	L	H	L	H	
-70	H	L	L	L	H	H	L	
-71	H	L	L	L	H	H	H	
-72	H	L	L	H	L	L	L	
-73	H	L	L	H	L	L	H	
-74	H	L	L	H	L	H	L	
-75	H	L	L	H	L	H	H	
-76	H	L	L	H	H	L	L	
-77	H	L	L	H	H	L	H	
-78	H	L	L	H	H	H	L	
-79	H	L	L	H	H	H	H	
-80	H	L	H	L	L	L	L	
-81	H	L	H	L	L	L	H	
-82	H	L	H	L	L	H	L	
-83	H	L	H	L	L	H	H	
-84	H	L	H	L	H	L	L	
-85	H	L	H	L	H	L	H	
-86	H	L	H	L	H	H	L	
-87	H	L	H	L	H	H	H	
-88	H	L	H	H	L	L	L	
-89	H	L	H	H	L	L	H	
-90	H	L	H	H	L	H	L	
-91	H	L	H	H	L	H	H	
-92	H	L	H	H	H	L	L	
-93	H	L	H	H	H	L	H	
-94	H	L	H	H	H	H	L	
-95	H	L	H	H	H	H	H	
-∞	H	H	H	H	H	H	H	

Application Example

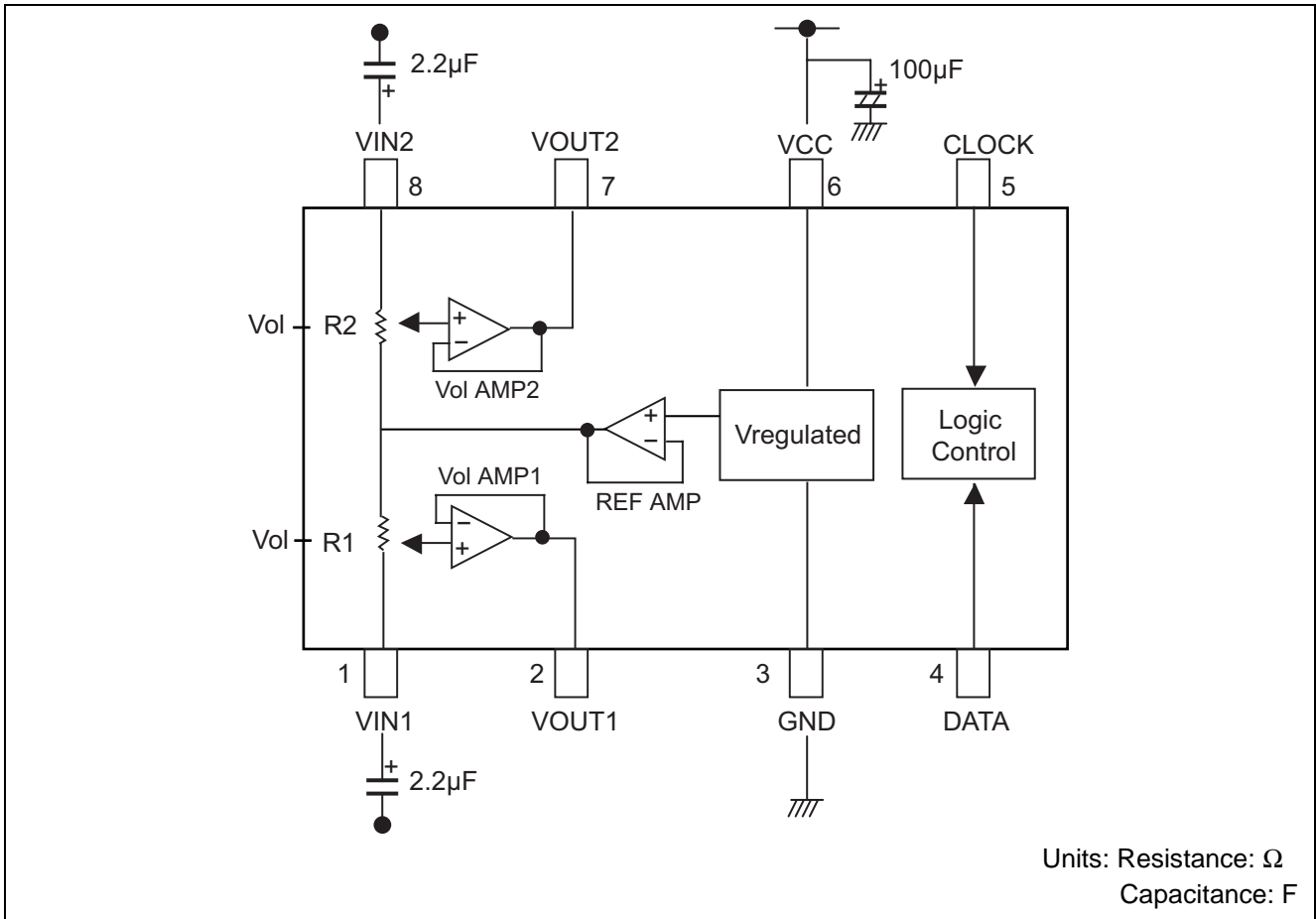

Package Dimensions

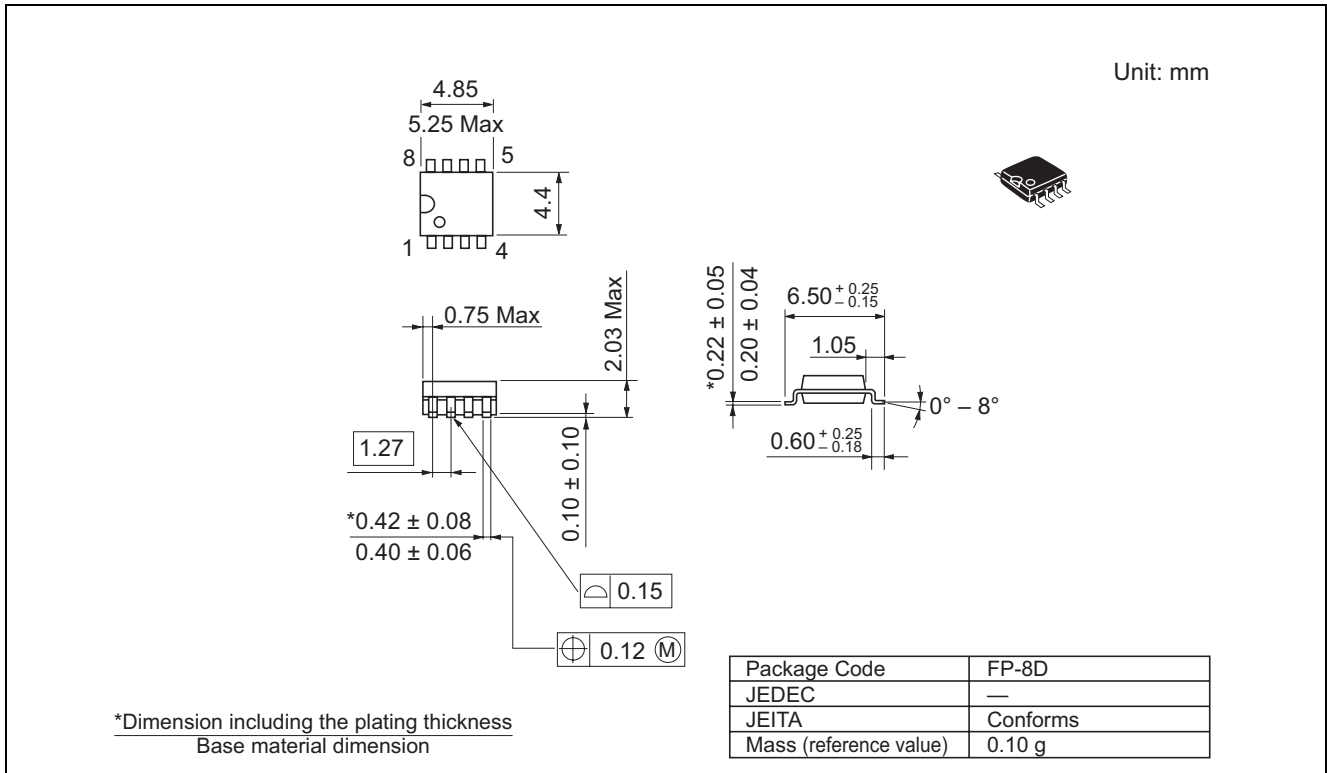

Keep safety first in your circuit designs!

1. Renesas Technology Corp. puts the maximum effort into making semiconductor products better and more reliable, but there is always the possibility that trouble may occur with them. Trouble with semiconductors may lead to personal injury, fire or property damage.
Remember to give due consideration to safety when making your circuit designs, with appropriate measures such as (i) placement of substitutive, auxiliary circuits, (ii) use of nonflammable material or (iii) prevention against any malfunction or mishap.

Notes regarding these materials

1. These materials are intended as a reference to assist our customers in the selection of the Renesas Technology Corp. product best suited to the customer's application; they do not convey any license under any intellectual property rights, or any other rights, belonging to Renesas Technology Corp. or a third party.
 2. Renesas Technology Corp. assumes no responsibility for any damage, or infringement of any third-party's rights, originating in the use of any product data, diagrams, charts, programs, algorithms, or circuit application examples contained in these materials.
 3. All information contained in these materials, including product data, diagrams, charts, programs and algorithms represents information on products at the time of publication of these materials, and are subject to change by Renesas Technology Corp. without notice due to product improvements or other reasons. It is therefore recommended that customers contact Renesas Technology Corp. or an authorized Renesas Technology Corp. product distributor for the latest product information before purchasing a product listed herein.
The information described here may contain technical inaccuracies or typographical errors.
Renesas Technology Corp. assumes no responsibility for any damage, liability, or other loss rising from these inaccuracies or errors.
Please also pay attention to information published by Renesas Technology Corp. by various means, including the Renesas Technology Corp. Semiconductor home page (<http://www.renesas.com>).
 4. When using any or all of the information contained in these materials, including product data, diagrams, charts, programs, and algorithms, please be sure to evaluate all information as a total system before making a final decision on the applicability of the information and products. Renesas Technology Corp. assumes no responsibility for any damage, liability or other loss resulting from the information contained herein.
 5. Renesas Technology Corp. semiconductors are not designed or manufactured for use in a device or system that is used under circumstances in which human life is potentially at stake. Please contact Renesas Technology Corp. or an authorized Renesas Technology Corp. product distributor when considering the use of a product contained herein for any specific purposes, such as apparatus or systems for transportation, vehicular, medical, aerospace, nuclear, or undersea repeater use.
 6. The prior written approval of Renesas Technology Corp. is necessary to reprint or reproduce in whole or in part these materials.
 7. If these products or technologies are subject to the Japanese export control restrictions, they must be exported under a license from the Japanese government and cannot be imported into a country other than the approved destination.
Any diversion or reexport contrary to the export control laws and regulations of Japan and/or the country of destination is prohibited.
 8. Please contact Renesas Technology Corp. for further details on these materials or the products contained therein.
-



RENESAS SALES OFFICES

<http://www.renesas.com>

Refer to "<http://www.renesas.com/en/network>" for the latest and detailed information.

Renesas Technology America, Inc.

450 Holger Way, San Jose, CA 95134-1368, U.S.A
Tel: <1> (408) 382-7500, Fax: <1> (408) 382-7501

Renesas Technology Europe Limited

Dukes Meadow, Millboard Road, Bourne End, Buckinghamshire, SL8 5FH, U.K.
Tel: <44> (1628) 585-100, Fax: <44> (1628) 585-900

Renesas Technology (Shanghai) Co., Ltd.

Unit 205, AZIA Center, No.133 Yincheng Rd (n), Pudong District, Shanghai 200120, China
Tel: <86> (21) 5877-1818, Fax: <86> (21) 6887-7898

Renesas Technology Hong Kong Ltd.

7th Floor, North Tower, World Finance Centre, Harbour City, 1 Canton Road, Tsimshatsui, Kowloon, Hong Kong
Tel: <852> 2265-6688, Fax: <852> 2730-6071

Renesas Technology Taiwan Co., Ltd.

10th Floor, No.99, Fushing North Road, Taipei, Taiwan
Tel: <886> (2) 2715-2888, Fax: <886> (2) 2713-2999

Renesas Technology Singapore Pte. Ltd.

1 Harbour Front Avenue, #06-10, Keppel Bay Tower, Singapore 098632
Tel: <65> 6213-0200, Fax: <65> 6278-8001

Renesas Technology Korea Co., Ltd.

Kukje Center Bldg. 18th Fl., 191, 2-ka, Hangang-ro, Yongsan-ku, Seoul 140-702, Korea
Tel: <82> (2) 796-3115, Fax: <82> (2) 796-2145

Renesas Technology Malaysia Sdn. Bhd

Unit 906, Block B, Menara Amcorp, Amcorp Trade Centre, No.18, Jalan Persiaran Barat, 46050 Petaling Jaya, Selangor Darul Ehsan, Malaysia
Tel: <603> 7955-9390, Fax: <603> 7955-9510