

CZTA94

**SURFACE MOUNT
PNP HIGH VOLTAGE
SILICON TRANSISTOR**

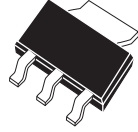

SOT-223 CASE

CentralTM
Semiconductor Corp.

DESCRIPTION:

The CENTRAL SEMICONDUCTOR CZTA94 type is a surface mount epoxy molded PNP silicon planar epitaxial transistors designed for extremely high voltage applications.

MARKING CODE: FULL PART NUMBER

MAXIMUM RATINGS: ($T_A=25^\circ\text{C}$)

Collector-Base Voltage
Collector-Emitter Voltage
Emitter-Base Voltage
Collector Current
Power Dissipation
Operating and Storage
Junction Temperature
Thermal Resistance

SYMBOL		UNITS
V_{CBO}	400	V
V_{CEO}	400	V
V_{EBO}	6.0	V
I_C	300	mA
P_D	2.0	W
T_J, T_{stg}	-65 to +150	$^\circ\text{C}$
θ_{JA}	62.5	$^\circ\text{C/W}$

ELECTRICAL CHARACTERISTICS: ($T_A=25^\circ\text{C}$ unless otherwise noted)

SYMBOL	TEST CONDITIONS	MIN	MAX	UNITS
I_{CBO}	$V_{CB}=350\text{V}$		100	nA
I_{CES}	$V_{CE}=350\text{V}$		500	nA
I_{EBO}	$V_{BE}=4.0\text{V}$		100	nA
BV_{CBO}	$I_C=100\mu\text{A}$	400		V
BV_{CES}	$I_C=100\mu\text{A}$	400		V
BV_{CEO}	$I_C=1.0\text{mA}$	400		V
BV_{EBO}	$I_E=10\mu\text{A}$	6.0		V
$V_{CE(SAT)}$	$I_C=1.0\text{mA}, I_B=0.1\text{mA}$		0.40	V
$V_{CE(SAT)}$	$I_C=10\text{mA}, I_B=1.0\text{mA}$		0.50	V
$V_{CE(SAT)}$	$I_C=50\text{mA}, I_B=5.0\text{mA}$		0.75	V
$V_{BE(SAT)}$	$I_C=10\text{mA}, I_B=1.0\text{mA}$		0.75	V
h_{FE}	$V_{CE}=10\text{V}, I_C=1.0\text{mA}$	40		
h_{FE}	$V_{CE}=10\text{V}, I_C=10\text{mA}$	50	200	
h_{FE}	$V_{CE}=10\text{V}, I_C=50\text{mA}$	45		
h_{FE}	$V_{CE}=10\text{V}, I_C=100\text{mA}$	20		
f_T	$V_{CE}=10\text{V}, I_C=10\text{mA}, f=10\text{MHz}$	20		MHz
C_{ob}	$V_{CB}=20\text{V}, I_E=0, f=1.0\text{MHz}$		7.0	pF
C_{ib}	$V_{EB}=0.5\text{V}, I_C=0, f=1.0\text{MHz}$		130	pF

R2 (17-June 2004)

SOT-223 CASE - MECHANICAL OUTLINE

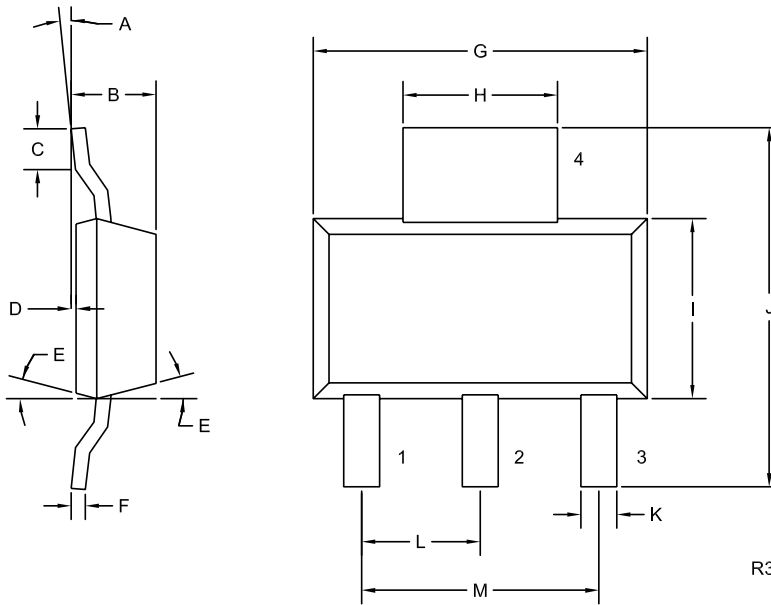

LEAD CODE:

- 1) BASE
- 2) COLLECTOR
- 3) EMITTER
- 4) COLLECTOR

MARKING CODE:

FULL PART NUMBER

DIMENSIONS				
SYMBOL	INCHES		MILLIMETERS	
	MIN	MAX	MIN	MAX
A	0°	10°	0°	10°
B	0.059	0.071	1.50	1.80
C	0.018	---	0.45	---
D	0.000	0.004	0.00	0.10
E	15°		15°	
F	0.009	0.014	0.23	0.35
G	0.248	0.264	6.30	6.70
H	0.114	0.122	2.90	3.10
I	0.130	0.146	3.30	3.70
J	0.264	0.287	6.70	7.30
K	0.024	0.033	0.60	0.85
L	0.091		2.30	
M	0.181		4.60	

SOT-223 (REV: R3)