

CBAT54
 CBAT54A
 CBAT54C
 CBAT54S

**SURFACE MOUNT
 SILICON SCHOTTKY DIODES**

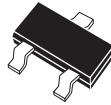

SOT-23 CASE

CentralTM Semiconductor Corp.

DESCRIPTION:

The CENTRAL SEMICONDUCTOR CBAT54 Series types are Silicon Schottky Diodes in an SOT-23 Surface Mount Package.

CBAT54: SINGLE
 CBAT54A: DUAL, COMMON ANODE
 CBAT54C: DUAL, COMMON CATHODE
 CBAT54S: DUAL, IN SERIES

MARKING CODE: CL4
MARKING CODE: CL42
MARKING CODE: CL43
MARKING CODE: CL44

MAXIMUM RATINGS: ($T_A=25^{\circ}\text{C}$)

	SYMBOL		UNITS
Continuous Reverse Voltage	V_R	30	V
Continuous Forward Current	I_F	200	mA
Peak Repetitive Forward Current	I_{FRM}	300	mA
Forward Surge Current, $t_p=10\text{ms}$	I_{FSM}	600	mA
Power Dissipation	P_D	350	mW
Operating and Storage			
Junction Temperature	T_J, T_{stg}	-65 to +150	$^{\circ}\text{C}$
Thermal Resistance	θ_{JA}	357	$^{\circ}\text{C/W}$

ELECTRICAL CHARACTERISTICS PER DIODE: ($T_A=25^{\circ}\text{C}$ unless otherwise noted)

SYMBOL	TEST CONDITIONS	MAX	UNITS
I_R	$V_R=25\text{V}$	2.0	μA
V_F	$I_F=0.1\text{mA}$	240	mV
V_F	$I_F=1.0\text{mA}$	320	mV
V_F	$I_F=10\text{mA}$	400	mV
V_F	$I_F=30\text{mA}$	500	mV
V_F	$I_F=100\text{mA}$	800	mV
C_d	$V_R=1.0\text{V}, f=1.0\text{ MHz}$	10	pF
t_{rr}	$I_F=I_R=10\text{mA}, I_{rr}=1.0\text{mA}, R_L=100\Omega$	5.0	ns

**SURFACE MOUNT
SILICON SCHOTTKY DIODES**

SOT-23 CASE - MECHANICAL OUTLINE

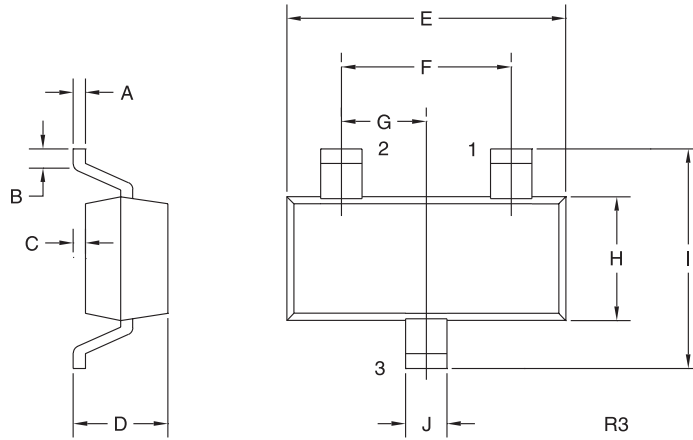

SYMBOL	DIMENSIONS			
	INCHES		MILLIMETERS	
	MIN	MAX	MIN	MAX
A	0.003	0.007	0.08	0.18
B	0.006	-	0.15	-
C	-	0.005	-	0.13
D	0.035	0.043	0.89	1.09
E	0.110	0.120	2.80	3.05
F	0.075		1.90	
G	0.037		0.95	
H	0.047	0.055	1.19	1.40
I	0.083	0.098	2.10	2.49
J	0.014	0.020	0.35	0.50

SOT-23 (REV: R3)

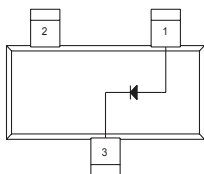

LEAD CODE:

CBAT54

- 1) Anode
- 2) No Connection
- 3) Cathode

**MARKING
CODE: CL4**

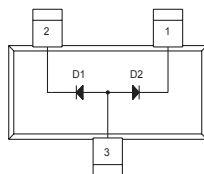

LEAD CODE:

CBAT54A

- 1) Cathode D2
- 2) Cathode D1
- 3) Anode D1, Anode D2

**MARKING
CODE: CL42**

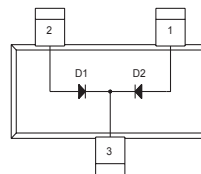

LEAD CODE:

CBAT54C

- 1) Anode D2
- 2) Anode D1
- 3) Cathode D1, Cathode D2

**MARKING
CODE: CL43**

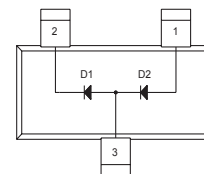

LEAD CODE:

CBAT54S

- 1) Anode D2
- 2) Cathode D1
- 3) Anode D1, Cathode D2

**MARKING
CODE: CL44**

R0 (13-January 2005)