

Low Voltage Adjustable Precision Shunt Regulator

Features

- Precise Reference Voltage to 1.24V
- Guaranteed 0.5% or 1% Reference Voltage Tolerance
- Sink Current Capability , 60mA to 100mA
- Quick Turn-on
- Adjustable Output Voltage , $V_O = V_{REF}$ to 20V
- Low Operational Cathode Current , 60mA Typical
- 0.1 Ω Typical Output Impedance
- SOT-23-5 Packages

Applications

- Linear Regulators
- Adjustable Power Supply
- Switching Power Supply

Symbol

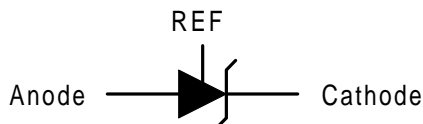

General Description

The APL1431L is a 3-terminal low voltage adjustable precision reference with specified thermal stability over applicable commercial temperature ranges . Output voltage may be set to any value between V_{REF} (1.24 V) and 20 V with two external resistors (see Figure 2) . When used with an photocoupler , the APL1431L is an ideal voltage reference in isolated feedback circuits for 1.24V to 12V switching-mode power supplies . This device has a typical output impedance of 0.1 Ω . Active output circuitry provides a very sharp turn-on characteristic , making the APL1431L excellent replacements for zener diodes in many applications , including on-board regulation and adjustable power supplies .

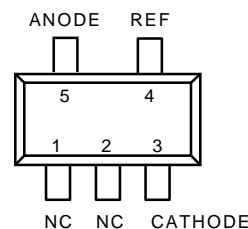

Functional Diagram

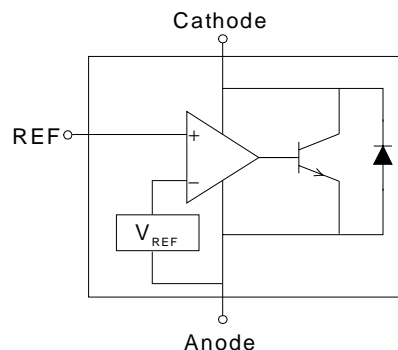

ANPEC reserves the right to make changes to improve reliability or manufacturability without notice, and advise customers to obtain the latest version of relevant information to verify before placing orders.

Ordering and Marking Information

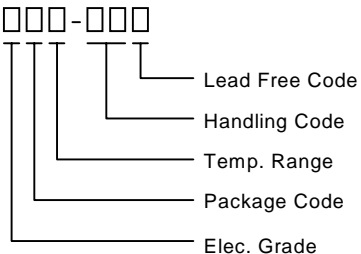
<p>APL1431L □□□-□□□</p>  <p>Lead Free Code Handling Code Temp. Range Package Code Elec. Grade</p>	<p>Elec. Grade A : 0.5% Reference Voltage Tolerance B : 1% Reference Voltage Tolerance</p> <p>Package Code B : SOT- 23 - 5</p> <p>Temp. Range C : 0 to 70 °C I : -40 to 85 °C</p> <p>Handling Code PB : Plastic Bag TB : Tape & Box TR : Tape & Reel</p> <p>Lead Free Code L : Lead Free Device Blank : Original Device</p>
<p>APL1431L B : 1431L</p>	

Absolute Maximum Ratings

Symbol	Parameter	Rating	Unit
V_{KA}	Cathode Voltage	20	V
I_K	Continuous Cathode Current	100	mA
I_{REF}	Reference Current	3	mA
θ_{JA}	Thermal Resistance from Junction to Ambient in Free Air SOT-23-5	357	°C/W
T_J	Operating Junction Temperature Range	-40 to 150	°C
T_{STG}	Storage Temperature Range	-65 to 150	°C
T_{SOL}	Lead Temperature Range, T_s (Soldering, 10sec)	260	°C

Electrical Characteristics $T_A = 25^\circ\text{C}$ (unless otherwise noted)

Symbol	Parameter	Test Conditions	APL1431L			Unit	
			Min.	Typ.	Max.		
V_{REF}	Reference Voltage	$V_{KA}=V_{REF}, I_K=10\text{mA}$ $T_A=25^\circ\text{C}$, (Fig. 1)	APL1431LA	1.234	1.240	1.246	V
			APL1431LB	1.228	1.240	1.252	
		$T_A = \text{full range}$ (see Note 1), (Fig. 1)	APL1431LA	1.222	1.240	1.258	
			APL1431LB	1.215	1.240	1.265	
V_{DEV}	V_{DEF} Temp Deviation	$T_A = \text{full range}$ (see Note 1), $V_{KA}=V_{REF}, I_K=10\text{mA}$, (Fig. 1)		5	15	mV	
$\frac{\Delta V_{REF}}{\Delta V_{KA}}$	Ratio of Change in V_{REF} to Change in Cathode Voltage	$I_K=10\text{mA}$, $\Delta V_{KA} = 16\text{V}$ to V_{REF} (Fig. 2)		-0.2	-1.0	mV/V	
I_{REF}	Reference Input Current	$I_K=10\text{mA}$, $R_1=10\text{k}\Omega$, $R_2=\infty$ (Fig. 2)		0.15	0.5	μA	

Electrical Characteristics $T_A = 25^\circ\text{C}$ (unless otherwise noted)

Symbol	Parameter	Test Conditions	APL1431L			Unit
			Min.	Typ.	Max.	
$I_{REF(DEV)}$	I_{REF} Temp Deviation	$T_A = \text{full range (see Note 1), } R_1 = 10\text{k}\Omega, R_2 = \infty, I_K = 10\text{mA}$, (Fig. 2)		0.05	0.3	μA
$I_{K(off)}$	Off-state cathode current	$V_{REF} = 0\text{V}$, (Fig. 3)	$V_K = 6\text{V}$	0.01	0.1	μA
			$V_K = 16\text{V}$	0.01	0.5	
Z_{KA}	Dynamic Output Impedance	$V_{KA} = V_{REF}, I_K = 100\mu\text{A}$ to 100mA , $f < 1\text{kHz}$, (Fig. 1)		0.1	0.3	Ω
$I_{K(MIN)}$	Minimum Operating Current	$V_{KA} = V_{REF}$, (Fig. 1)		60	80	μA

Note : 1. Full temperature range is 0°C to 70°C for APL1431LXXC, and -40°C to 85°C for APL1431LXXI.

Test Circuits

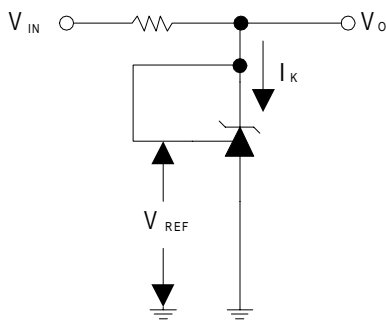

Figure 1. Test Circuit for $V_{KA} = V_{REF}, V_O = V_{KA} = V_{REF}$

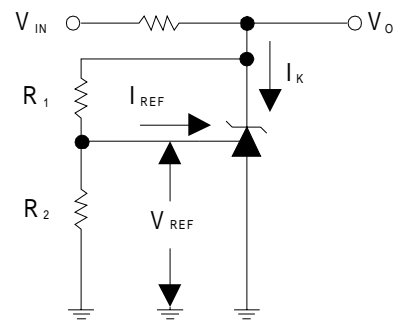

Figure 2. Test Circuit for $V_{KA} > V_{REF}, V_O = V_{KA} = V_{REF} \times (1 + R_1/R_2) + I_{REF} \times R_1$

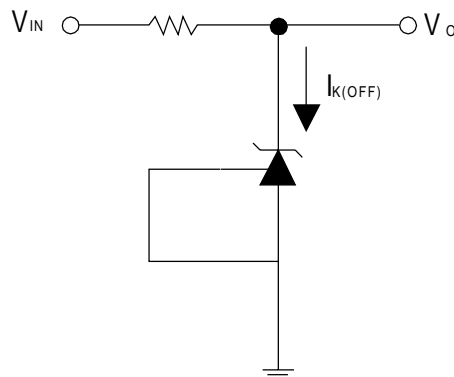
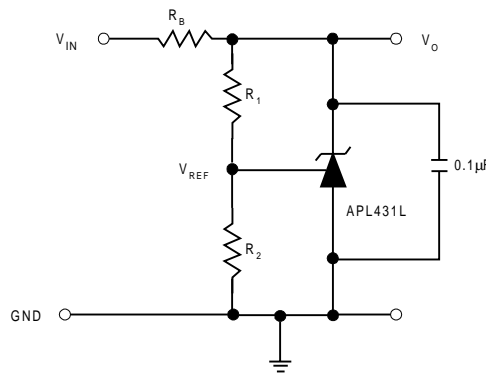
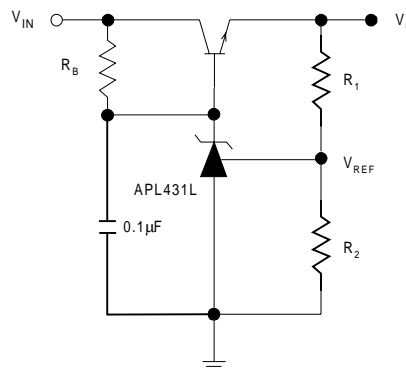

Figure 3. Test Circuit for $I_{K(OFF)}$

Application Schematic



Precision Voltage Reference



Precision Voltage Regulator

Notes for Application Circuits:

1) To improve the stability of output voltage , a 0.1µF capacitor between cathode and anode of APL431L is strongly recommended.

2) Set V_O according to the following equation:

$$V_O = V_{REF} (1 + R_1 / R_2) + I_{REF} R_1$$

3) Choose the value for R_B as follows:

- The maximum limit for R_B should be such that the cathode current (I_K) is greater than the minimum operating current (60µA) at $V_{IN(MIN)}$.
- The minimum limit for R_B should be such that the cathode current (I_K) does not exceed 100mA under all load conditions, and the instantaneous turn-on value for I_K does not exceed 150mA . Both of the following conditions must be met :

$$R_{B,MIN} \geq V_{IN(MAX)} / 150mA \text{ (to limit instantaneous turn-on } I_K)$$

$$R_{B,MIN} \geq V_{IN(MAX)} - V_O / I_{O(MIN)} + 100mA \text{ (to limit } I_K \text{ under normal operating conditions)}$$

Typical Characteristics

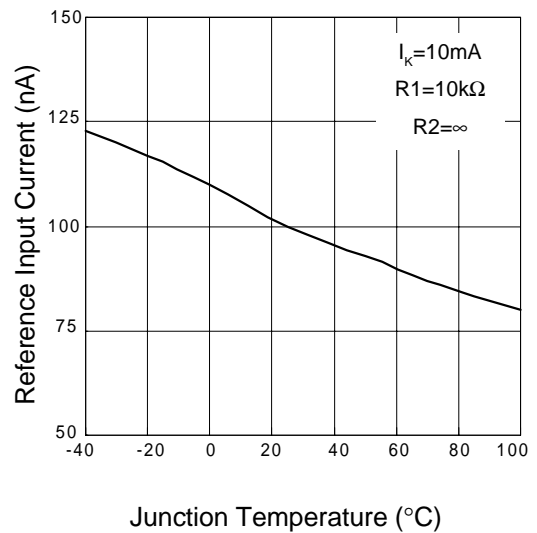
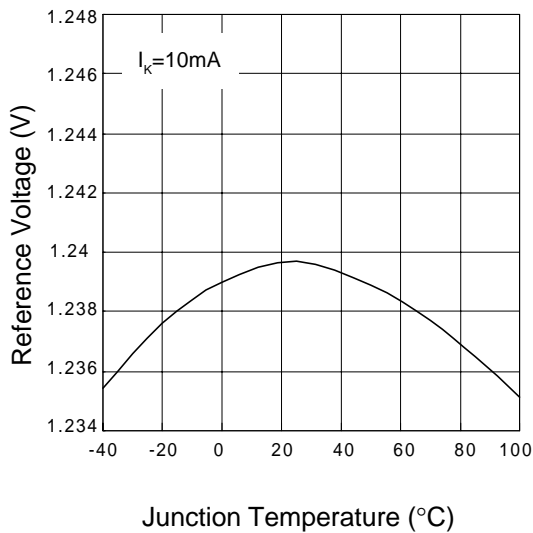
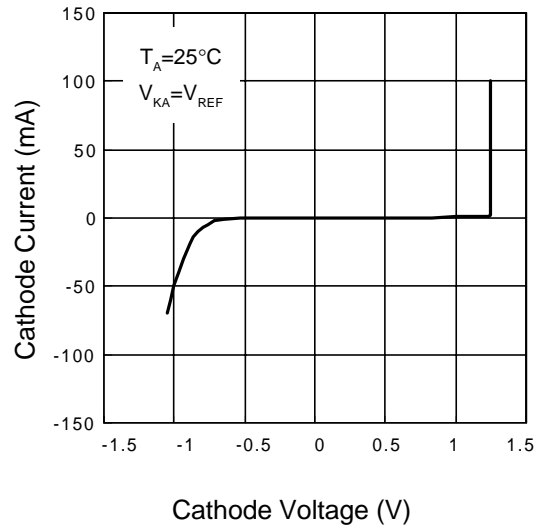
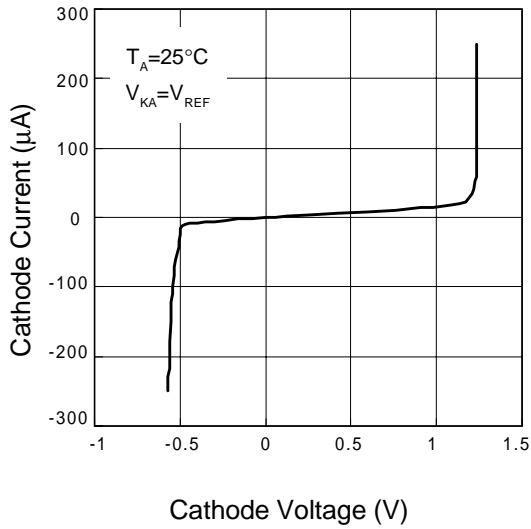

Typical Characteristics (Cont.)

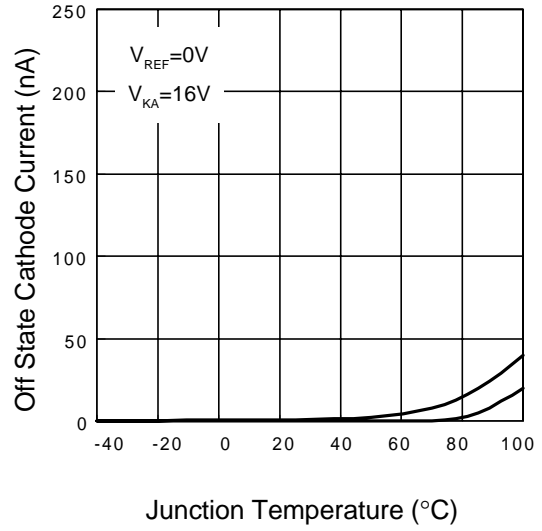
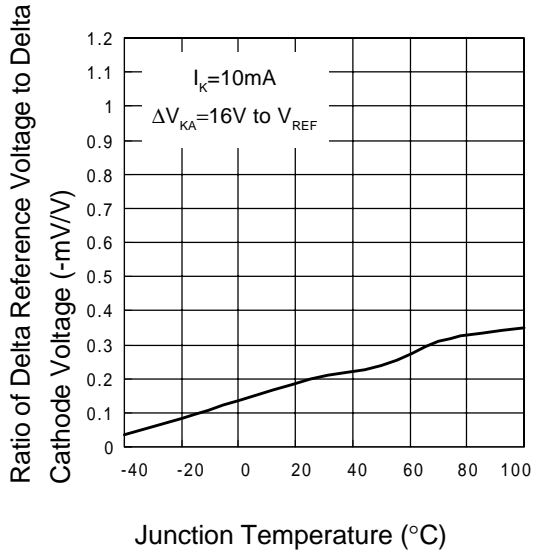

Packaging Information

SOT-23-5

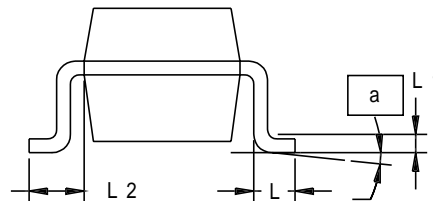
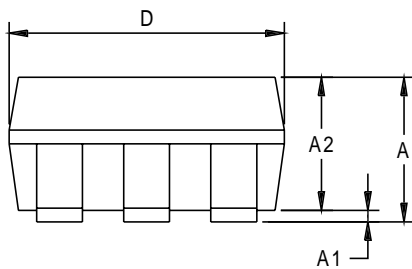
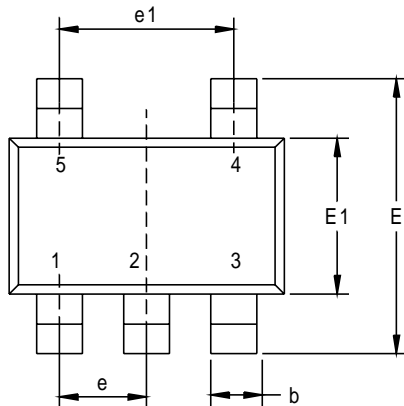

Dim	Millimeters		Inches	
	Min.	Max.	Min.	Max.
A	0.95	1.45	0.037	0.057
A1	0.05	0.15	0.002	0.006
A2	0.90	1.30	0.035	0.051
b	0.30	0.50	0.011	0.019
D	2.8	3.00	0.110	0.118
E	2.6	3.00	0.102	0.118
E1	1.5	1.70	0.059	0.067
e	0.95BSC		0.037BSC	
e1	1.90BSC		0.074BSC	
L	0.35	0.55	0.014	0.022
L1	0.20 BSC		0.008 BSC	
L2	0.5	0.7	0.020	0.028
N	5		5	
α	0°	10°	0°	10°

Physical Specifications

Terminal Material	Solder-Plated Copper (Solder Material : 90/10 or 63/37 SnPb), 100%Sn
Lead Solderability	Meets EIA Specification RSI86-91, ANSI/J-STD-002 Category 3.

Reflow Condition (IR/Convection or VPR Reflow)

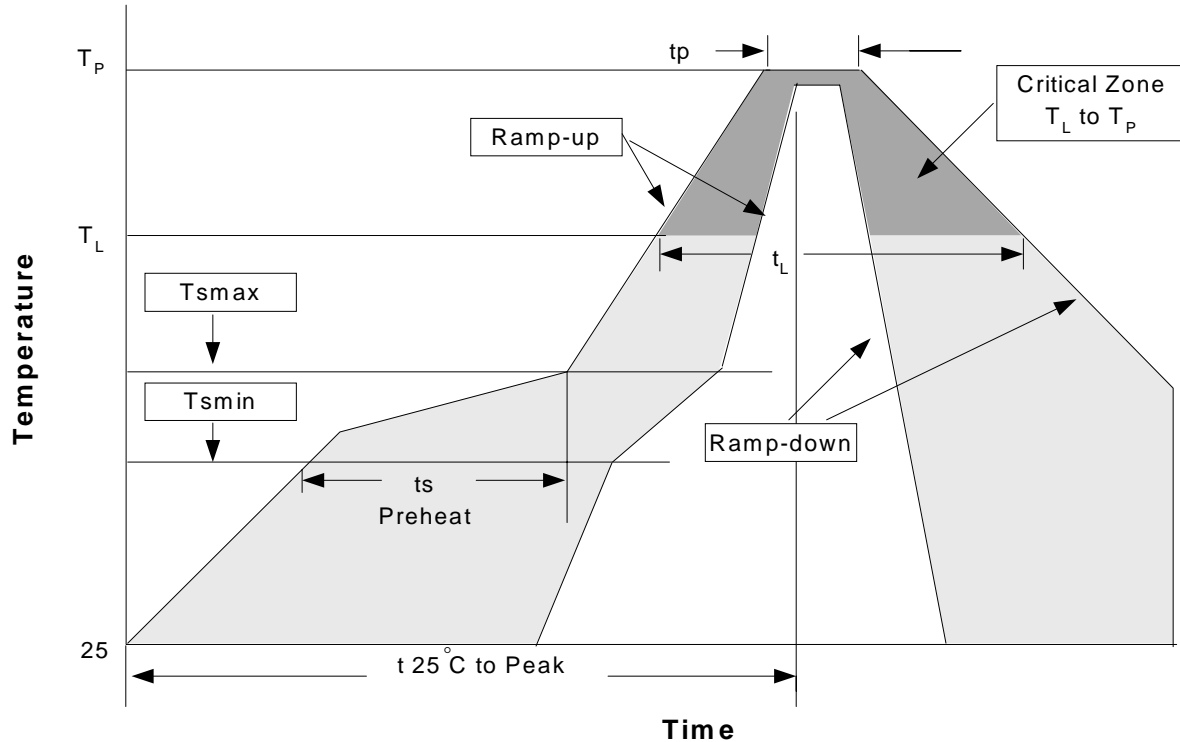

Classification Reflow Profiles

Profile Feature	Sn-Pb Eutectic Assembly		Pb-Free Assembly	
	Large Body	Small Body	Large Body	Small Body
Average ramp-up rate (T_L to T_P)	3°C/second max.		3°C/second max.	
Preheat				
- Temperature Min (T_{smin})	100°C		150°C	
- Temperature Mix (T_{smax})	150°C		200°C	
- Time (min to max)(t_s)	60-120 seconds		60-180 seconds	
T_{smax} to T_L			3°C/second max	
- Ramp-up Rate				
T_{smax} to T_L				
- Temperature(T_L)	183°C		217°C	
- Time (t_L)	60-150 seconds		60-150 seconds	
Peak Temperature(T_p)	225 +0/-5°C	240 +0/-5°C	245 +0/-5°C	250 +0/-5°C
Time within 5°C of actual Peak Temperature(t_p)	10-30 seconds	10-30 seconds	10-30 seconds	20-40 seconds
Ramp-down Rate	6°C/second max.		6°C/second max.	
Time 25°C to Peak Temperature	6 minutes max.		8 minutes max.	

Note: All temperatures refer to topside of the package. Measured on the body surface.

Reliability Test Program

Test item	Method	Description
SOLDERABILITY	MIL-STD-883D-2003	245°C, 5 SEC
HOLT	MIL-STD-883D-1005.7	1000 Hrs Bias @ 125°C
PCT	JESD-22-B,A102	168 Hrs, 100%RH, 121°C
TST	MIL-STD-883D-1011.9	-65°C~150°C, 200 Cycles
ESD	MIL-STD-883D-3015.7	VHBM > 2KV, VMM > 200V
Latch-Up	JESD 78	10ms, $1_{tr} > 100mA$

Carrier Tape & Reel Dimensions

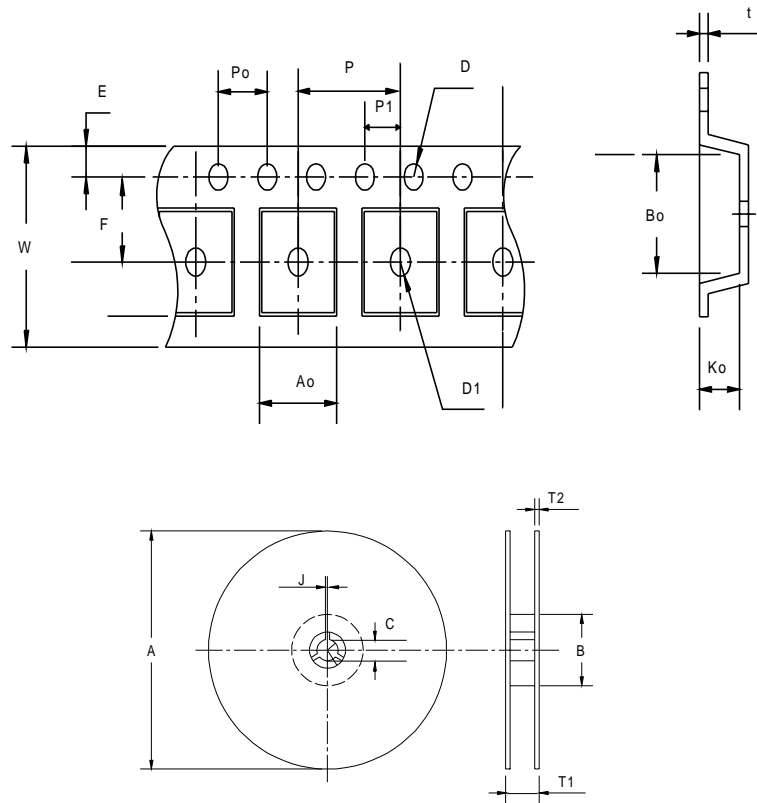

Application	A	B	C	J	T1	T2	W	P	E
SOT-23-5	178 ± 1	72 ± 1.0	$13.0 + 0.2$	2.5 ± 0.15	8.4 ± 2	1.5 ± 0.3	8.0 ± 0.3	4 ± 0.1	1.75 ± 0.1
	F	D	D1	Po	P1	Ao	Bo	Ko	t
	3.5 ± 0.05	1.5 ± 0.1	1.5 ± 0.1	4.0 ± 0.1	2.0 ± 0.1	3.15 ± 0.1	3.2 ± 0.1	1.4 ± 0.1	0.2 ± 0.033

(mm)

Cover Tape Dimensions

Application	Carrier Width	Cover Tape Width	Devices Per Reel
SOT- 23-5	8	5.3	3000

Customer Service

Anpec Electronics Corp.

Head Office :

5F, No. 2 Li-Hsin Road, SBIP,

Hsin-Chu, Taiwan, R.O.C.

Tel : 886-3-5642000

Fax : 886-3-5642050

Taipei Branch :

7F, No. 137, Lane 235, Pac Chiao Rd.,

Hsin Tien City, Taipei Hsien, Taiwan, R. O. C.

Tel : 886-2-89191368

Fax : 886-2-89191369