

## Push Pin Attachment Method

**Part Number: 372924M02000**

(Vis Number: 028086)

**This part is in stock and available for immediate delivery:**

Contact your [local sales rep](#)

BGA Surface	Interface	Heat Sink Finish	Part Class
All	None	Green Anodize	A

### Features and Benefits

- Configurations are available for a wide range of BGA package sizes
- All Heat Sinks utilize industry standard hole patterns
- Plastic push pins are standard for 1.5mm pc board and 2.5mm thick BGA packages. Consult Aavid Thermalloy for versions available with brass push pins for more rugged applications or thicker devices
- Minimal diameter holes are necessary for mounting to PC Board (see PCB Hole Pattern)
- Each Heat Sink utilizes a phase change pad as the interface for optimal performance, unless otherwise noted



Width	Length	Height	Fin Thickness Across Width	Fin Thickness Across Length	Base Thickness	# of fins across width	# of fins across length
37.4mm	37.4mm	6mm	1.4mm	1.5mm	1.3mm	9	9

### Mechanical Outline Drawing

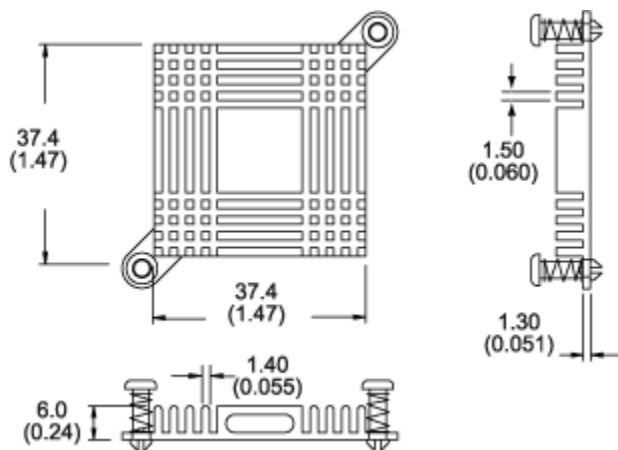

Unless otherwise shown, tolerances are  $\pm 0.38 (\pm 0.015)$

### Recommended PCB Hole Pattern

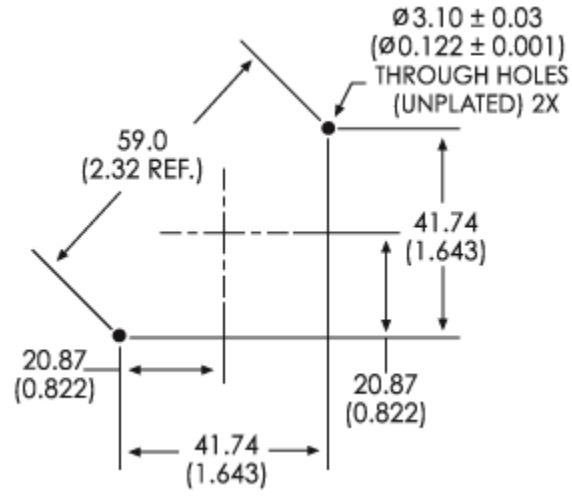

## Thermal Performance

* $\theta_n$	** $\theta_f$
32.6	9.91

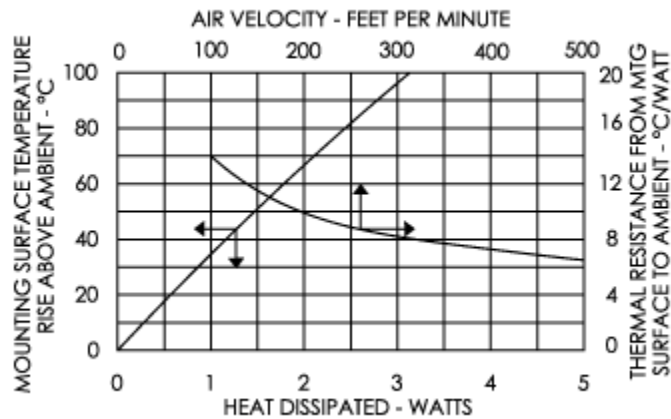

\*Natural convection thermal resistance is based on a 75 °C heat sink temperature rise.

\*\*Forced convection thermal resistance based on an entering 1.0 m/s (200 lfm) airflow.  
Due to various heat dissipation paths within a BGA device, please test the heat sink in your application.

---

This data sheet represents only one of a broad range of products we make to cool electronics.  
Our representatives can help you configure a complete cooling solution for your individual applications.

Visit us at [www.aavidthermalloy.com](http://www.aavidthermalloy.com) • [info@aavid.com](mailto:info@aavid.com) • ©2002 Aavid Thermalloy, LLC