

# DATA SHEET

**LTE42008R**

**NPN microwave power transistor**

Product specification  
Supersedes data of June 1992  
File under Discrete Semiconductors, SC15

1997 Feb 24

# NPN microwave power transistor

# LTE42008R

### FEATURES

- Diffused emitter ballasting resistors provide excellent current sharing and withstanding a high VSWR
- Gold metallization realizes very stable characteristics and excellent lifetime
- Input matching cell improves input impedance and allows an easier design of circuits.

### APPLICATION

- Common emitter class-A linear power amplifiers up to 4.2 GHz.

### DESCRIPTION

NPN silicon planar epitaxial microwave power transistor in a SOT440A metal ceramic flange package with the emitter connected to the flange.

### PINNING - SOT440A

PIN	DESCRIPTION
1	collector
2	base
3	emitter connected to flange

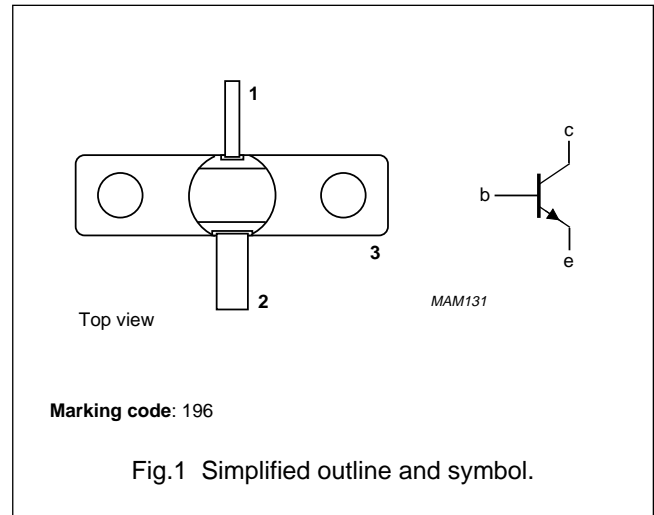

### QUICK REFERENCE DATA

Microwave performance up to  $T_{mb} = 25\text{ }^{\circ}\text{C}$  in a common emitter class-A amplifier.

MODE OF OPERATION	f (GHz)	V <sub>CE</sub> (V)	I <sub>C</sub> (mA)	P <sub>L1</sub> (mW)	G <sub>po</sub> (dB)	Z <sub>i</sub> (Ω)	Z <sub>L</sub> (Ω)
Class-A (CW) linear	4.2	16	250	≥800	>7	7.5 + j23.5	2.5 – j9

### WARNING

Product and environmental safety - toxic materials

This product contains beryllium oxide. The product is entirely safe provided that the BeO slab is not damaged. All persons who handle, use or dispose of this product should be aware of its nature and of the necessary safety precautions. After use, dispose of as chemical or special waste according to the regulations applying at the location of the user. It must never be thrown out with the general or domestic waste.

NPN microwave power transistor

LTE42008R

**LIMITING VALUES**

In accordance with the Absolute Maximum Rating System (IEC 134).

SYMBOL	PARAMETER	CONDITIONS	MIN.	MAX.	UNIT
V <sub>CBO</sub>	collector-base voltage	open emitter	–	40	V
V <sub>CER</sub>	collector-emitter voltage	R <sub>BE</sub> = 250 Ω	–	20	V
V <sub>CEO</sub>	collector-emitter voltage	open base	–	16	V
V <sub>EBO</sub>	emitter-base voltage	open collector	–	3	V
I <sub>C</sub>	collector current (DC)		–	450	mA
P <sub>tot</sub>	total power dissipation	T <sub>mb</sub> ≤ 75 °C	–	7.5	W
T <sub>stg</sub>	storage temperature		–65	+200	°C
T <sub>j</sub>	operating junction temperature		–	200	°C
T <sub>slid</sub>	soldering temperature	at 0.3 mm from case; t = 10 s	–	235	°C

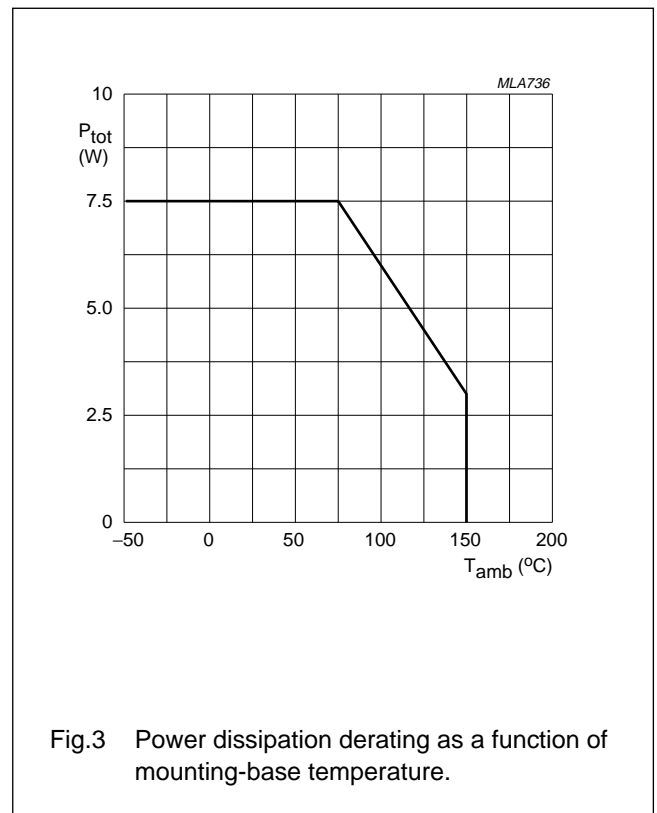
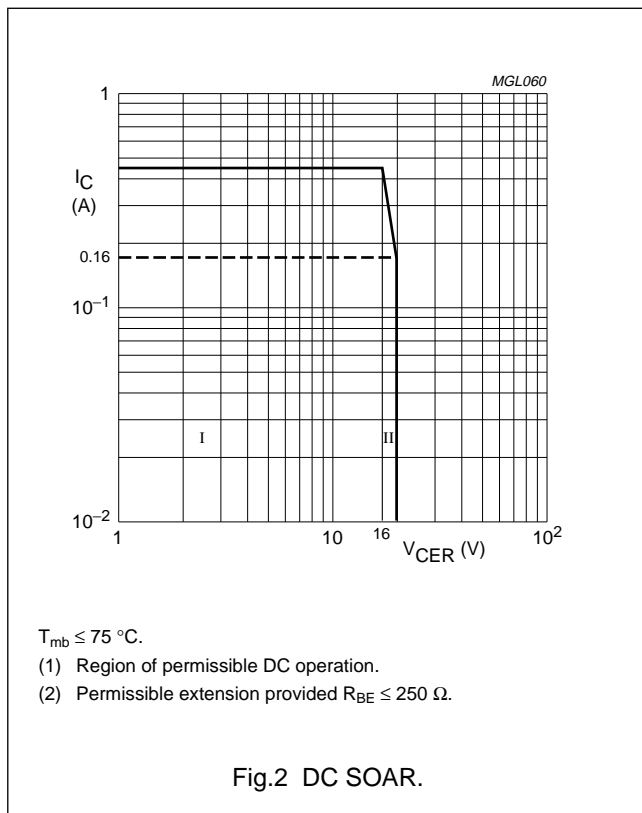

## NPN microwave power transistor

LTE42008R

## THERMAL CHARACTERISTICS

SYMBOL	PARAMETER	CONDITIONS	MAX.	UNIT
$R_{th\ j-mb}$	thermal resistance from junction to mounting-base	$T_j = 70\text{ °C}$	12	K/W
$R_{th\ mb-h}$	thermal resistance from mounting-base to heatsink	$T_j = 70\text{ °C}$ ; note 1	0.7	K/W

## Note

1. See "Mounting recommendations in the General part of handbook SC15".

## CHARACTERISTICS

$T_{mb} = 25\text{ °C}$  unless otherwise specified.

SYMBOL	PARAMETER	CONDITIONS	MIN.	TYP.	MAX.	UNIT
$I_{CBO}$	collector cut-off current	$V_{CB} = 20\text{ V}$ ; $I_E = 0$	–	–	150	$\mu\text{A}$
		$V_{CB} = 40\text{ V}$ ; $I_E = 0$	–	–	1	mA
$I_{CER}$	emitter cut-off current	$V_{CE} = 20\text{ V}$ ; $R_{BE} = 250\ \Omega$	–	–	0.5	mA
$I_{EBO}$	emitter cut-off current	$V_{EB} = 1.5\text{ V}$ ; $I_C = 0$	–	–	0.4	$\mu\text{A}$
$h_{FE}$	DC current gain	$V_{CE} = 5\text{ V}$ ; $I_C = 250\text{ mA}$	15	–	150	
$C_{cb}$	collector-base capacitance	$V_{CB} = 16\text{ V}$ ; $V_{EB} = 1.5\text{ V}$ ; $I_E = I_C = 0$ ; $f = 1\text{ MHz}$	–	2	–	pF
$C_{ce}$	collector-emitter capacitance	$V_{CE} = 16\text{ V}$ ; $V_{EB} = 1.5\text{ V}$ ; $I_E = I_C = 0$ ; $f = 1\text{ MHz}$	–	1.5	–	pF
$C_{eb}$	emitter-base capacitance	$V_{CB} = 10\text{ V}$ ; $V_{EB} = 1\text{ V}$ ; $I_C = I_E = 0$ ; $f = 1\text{ MHz}$	–	20	–	pF

## NPN microwave power transistor

## LTE42008R

**Table 1** Common-emitter scattering parameters:  $V_{CE} = 16\text{ V}$ ;  $I_C = 250\text{ mA}$ ;  $T_{mb} = 25\text{ °C}$ ;  $Z_o = 50\text{ }\Omega$ ; typical values

f (MHz)	S <sub>11</sub>		S <sub>21</sub>		S <sub>12</sub>		S <sub>22</sub>	
	MAGNITUDE (ratio)	ANGLE (deg)	MAGNITUDE (ratio)	ANGLE (deg)	MAGNITUDE (ratio)	ANGLE (deg)	MAGNITUDE (ratio)	ANGLE (deg)
2000	0.80	160	0.061	61.5	1.40	42.4	0.45	-172.7
2100	0.79	157	0.065	59.4	1.37	38.0	0.44	-173.7
2200	0.79	155	0.068	56.5	1.36	34.0	0.44	-175.5
2300	0.80	153	0.071	54.3	1.35	29.9	0.45	-176.5
2400	0.79	151	0.074	52.2	1.35	25.3	0.45	-176.9
2500	0.79	150	0.079	50.1	1.35	21.1	0.45	-177.6
2600	0.78	148	0.085	48.4	1.34	16.2	0.46	-178.0
2700	0.77	147	0.090	45.1	1.34	11.8	0.47	-178.3
2800	0.75	146	0.095	41.7	1.35	7.6	0.48	-178.6
2900	0.73	144	0.099	38.3	1.38	2.9	0.50	-178.9
3000	0.71	143	0.104	35.4	1.40	-2.6	0.52	-178.8
3100	0.67	143	0.111	31.8	1.42	-8.3	0.55	-179.2
3200	0.64	141	0.116	27.4	1.43	-14.1	0.58	-179.9
3300	0.60	141	0.121	21.7	1.44	-20.4	0.62	178.8
3400	0.56	142	0.124	15.7	1.48	-28.1	0.66	176.9
3500	0.52	143	0.124	11.2	1.49	-36.4	0.70	174.4
3600	0.49	146	0.124	5.2	1.48	-45.1	0.74	171.3
3700	0.47	149	0.122	-2.2	1.47	-53.9	0.79	166.8
3800	0.46	154	0.118	-9.7	1.45	-63.1	0.84	161.9
3900	0.48	159	0.112	-15.7	1.41	-72.9	0.87	156.7
4000	0.51	161	0.106	-22.8	1.34	-82.5	0.91	150.7
4100	0.56	162	0.096	-29.4	1.26	-91.7	0.94	144.8
4200	0.61	161	0.083	-34.5	1.18	-100.1	0.96	138.6
4300	0.67	158	0.068	-37.4	1.08	-108.8	0.97	132.5
4400	0.71	155	0.054	-38.7	0.99	-117.8	0.98	127.3
4500	0.76	152	0.042	-35.4	0.90	-126.5	0.99	122.2
4600	0.79	147	0.031	-26.6	0.81	-134.7	0.99	117.2
4700	0.81	143	0.025	-5.6	0.73	-143.0	0.99	113.7
4800	0.82	140	0.026	28.8	0.66	-151.2	0.99	110.0
4900	0.82	136	0.034	40.1	0.59	-158.8	0.99	106.5
5000	0.82	132	0.043	52.4	0.53	-167.3	0.98	103.2

NPN microwave power transistor

LTE42008R

APPLICATION INFORMATION

Microwave performance up to  $T_{mb} = 25\text{ }^{\circ}\text{C}$  in a common emitter class-A test circuit; note 1.

MODE OF OPERATION	f (GHz)	V <sub>CE</sub> (V) <sup>(2)</sup>	I <sub>C</sub> (mA) <sup>(2)</sup>	P <sub>L1</sub> (mW) <sup>(3)</sup>	G <sub>po</sub> (dB) <sup>(4)</sup>	Z <sub>i</sub> (Ω)	Z <sub>L</sub> (Ω)
Class-A (CW)	4.2	16	250	≥800 (29) typ. 940 (29.7)	≥7 typ. 7.5	7.5 + j40	4 + j4

Notes

1. Circuit consists of prematching circuit boards in combination with complementary input and output slug tuners.
2. I<sub>C</sub> and V<sub>CE</sub> regulated.
3. Load power for 1 dB compressed power gain.
4. Low level power gain associated with P<sub>L1</sub>.

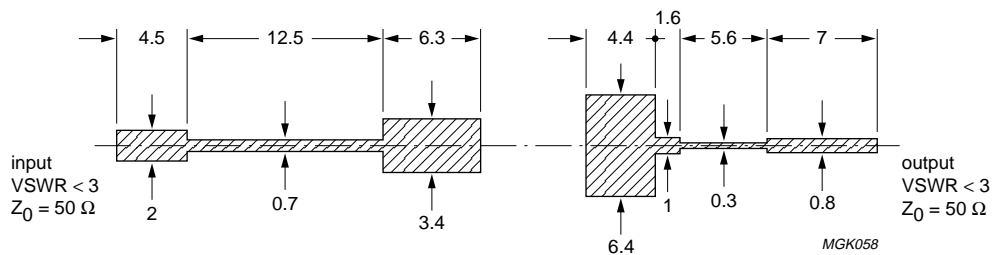

Dimensions in mm.

Input striplines on a double copper-clad printed-circuit board with PTFE fibreglass dielectric ( $\epsilon_r = 2.54$ ); thickness: 1.6 mm.

Output striplines on a double copper-clad Rexolite printed-circuit board with dielectric ( $\epsilon_r = 2.4$ ); thickness: 0.25 mm.

Fig.4 Prematching test circuit board.

NPN microwave power transistor

LTE42008R

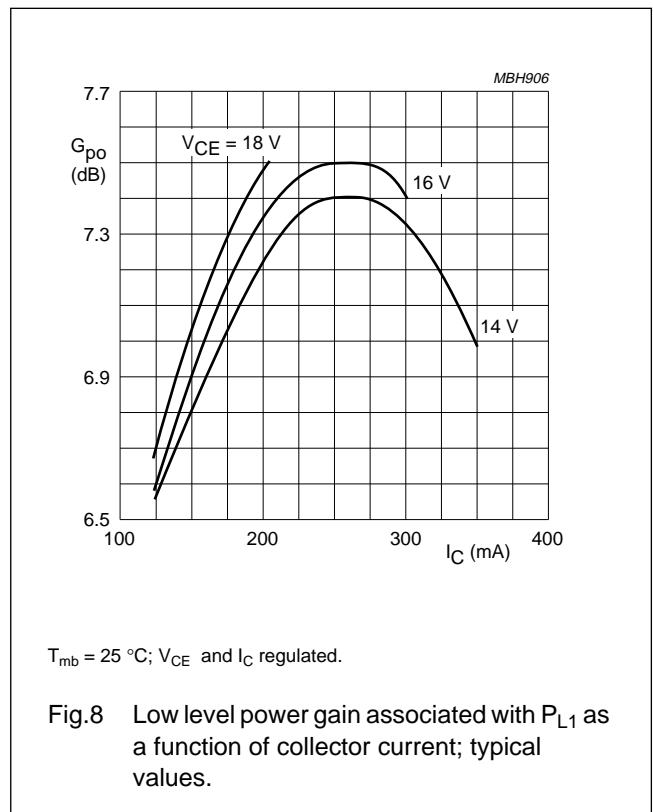
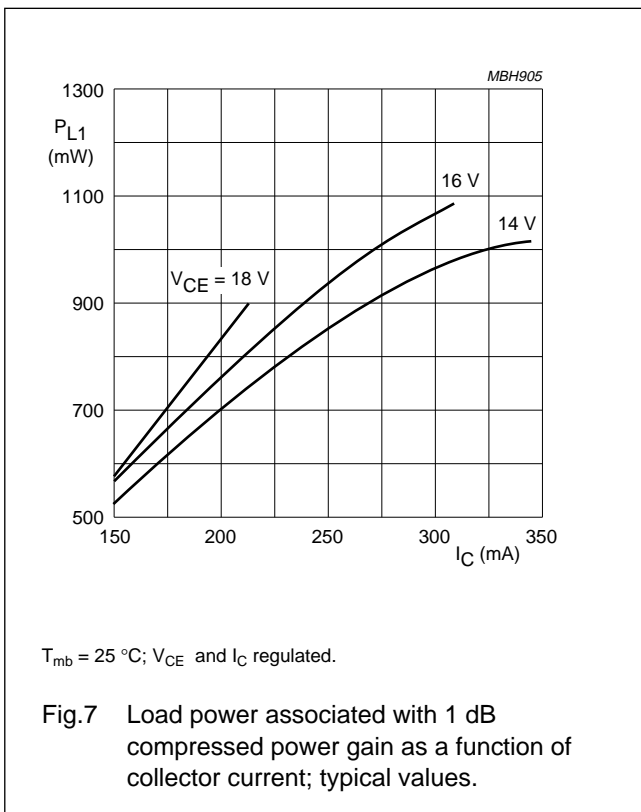
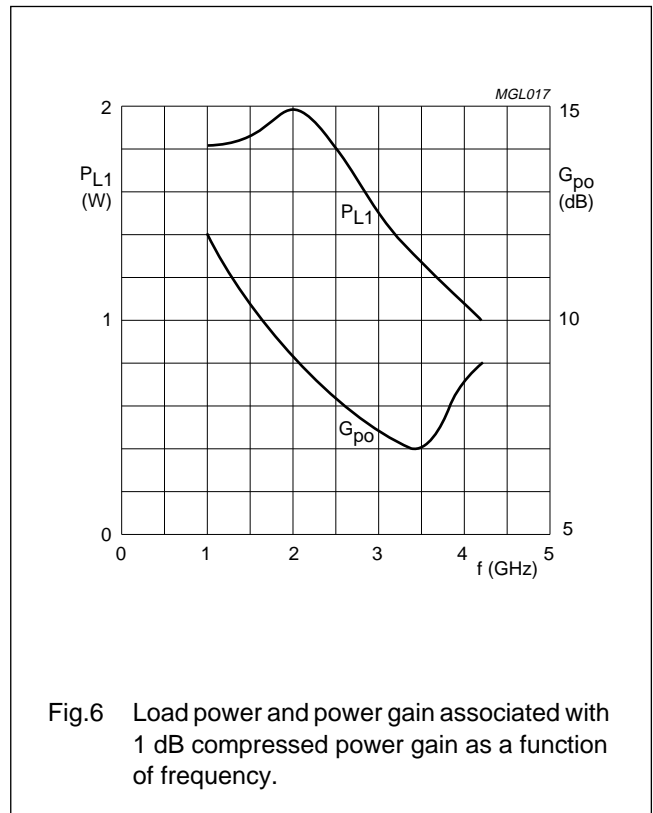
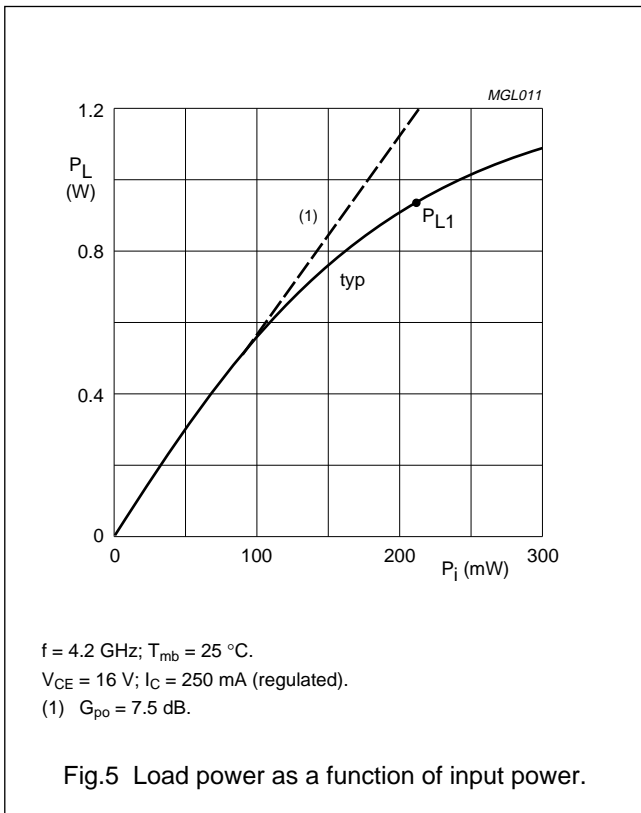

NPN microwave power transistor

LTE42008R

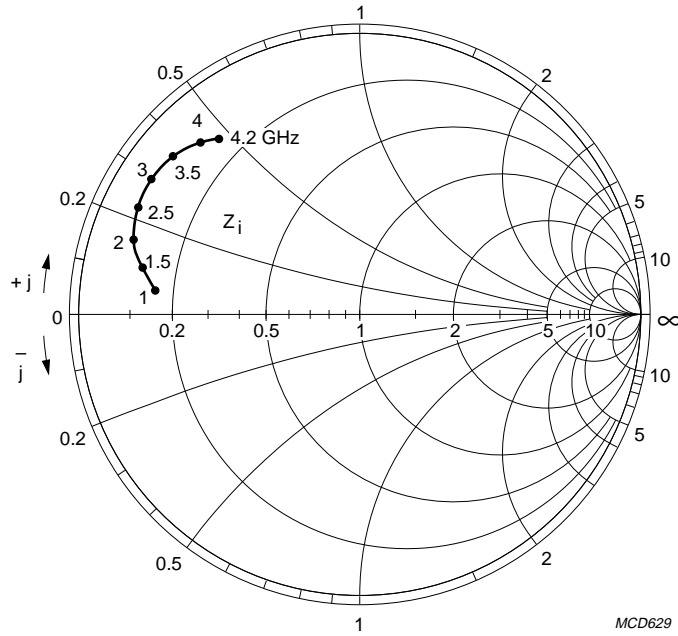

$V_{CE} = 16\text{ V}$ ;  $I_C = 250\text{ mA}$  (regulated).  
 $Z_o = 50\ \Omega$ ;  $T_{mb} = 25\text{ }^\circ\text{C}$ .

Fig.9 Input impedance as a function of frequency for  $P_{L1}$ ; typical values.

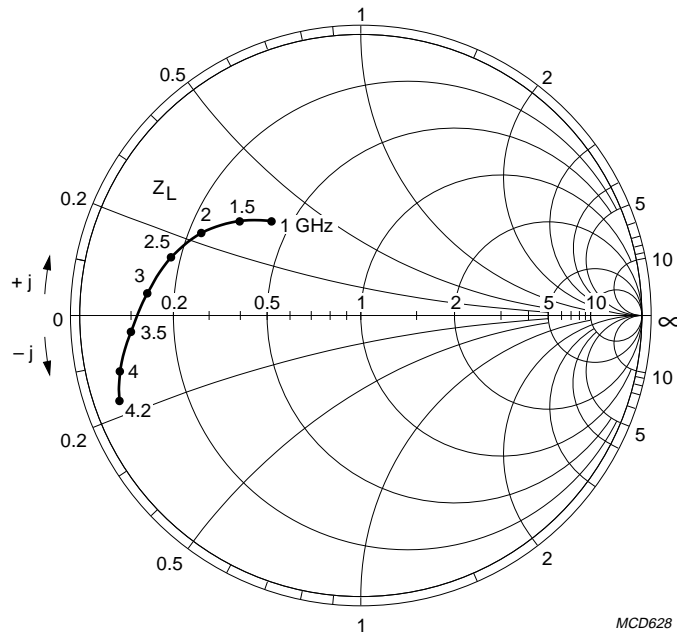

$V_{CE} = 16\text{ V}$ ;  $I_C = 250\text{ mA}$  (regulated).  
 $Z_o = 50\ \Omega$ ;  $T_{mb} = 25\text{ }^\circ\text{C}$ .

Fig.10 Optimum load impedance as a function of frequency for  $P_{L1}$ ; typical values.

NPN microwave power transistor

LTE42008R

PACKAGE OUTLINE

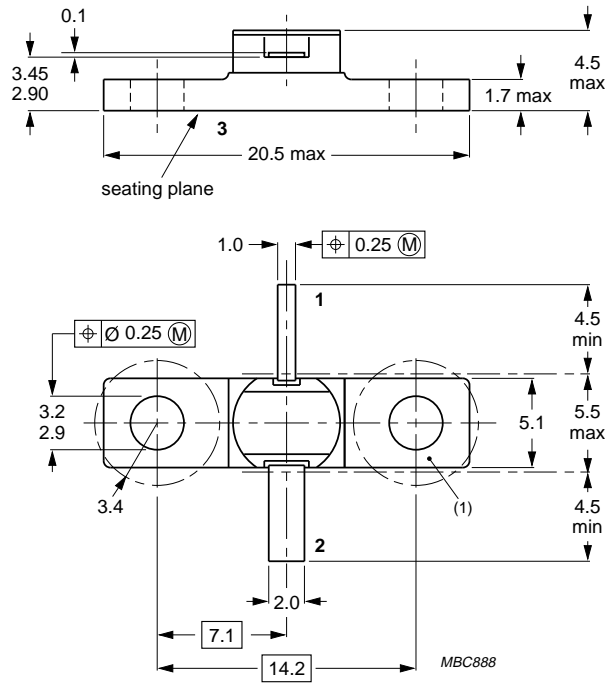

Dimensions in mm.  
 Torque on screw: Max. 0.4 Nm.  
 Recommended screw: M2.5.

(1) Flatness of this area ensures full thermal contact with bolt head.

Fig.11 SOT440A.

## NPN microwave power transistor

LTE42008R

**DEFINITIONS**

<b>Data Sheet Status</b>	
Objective specification	This data sheet contains target or goal specifications for product development.
Preliminary specification	This data sheet contains preliminary data; supplementary data may be published later.
Product specification	This data sheet contains final product specifications.
<b>Limiting values</b>	
Limiting values given are in accordance with the Absolute Maximum Rating System (IEC 134). Stress above one or more of the limiting values may cause permanent damage to the device. These are stress ratings only and operation of the device at these or at any other conditions above those given in the Characteristics sections of the specification is not implied. Exposure to limiting values for extended periods may affect device reliability.	
<b>Application information</b>	
Where application information is given, it is advisory and does not form part of the specification.	

**LIFE SUPPORT APPLICATIONS**

These products are not designed for use in life support appliances, devices, or systems where malfunction of these products can reasonably be expected to result in personal injury. Philips customers using or selling these products for use in such applications do so at their own risk and agree to fully indemnify Philips for any damages resulting from such improper use or sale.

NPN microwave power transistor

LTE42008R

---

**NOTES**

# Philips Semiconductors – a worldwide company

**Argentina:** see South America

**Australia:** 34 Waterloo Road, NORTH RYDE, NSW 2113,  
Tel. +61 2 9805 4455, Fax. +61 2 9805 4466

**Austria:** Computerstr. 6, A-1101 WIEN, P.O. Box 213,  
Tel. +43 1 60 101, Fax. +43 1 60 101 1210

**Belarus:** Hotel Minsk Business Center, Bld. 3, r. 1211, Volodarski Str. 6,  
220050 MINSK, Tel. +375 172 200 733, Fax. +375 172 200 773

**Belgium:** see The Netherlands

**Brazil:** see South America

**Bulgaria:** Philips Bulgaria Ltd., Energoproject, 15th floor,  
51 James Bourchier Blvd., 1407 SOFIA,  
Tel. +359 2 689 211, Fax. +359 2 689 102

**Canada:** PHILIPS SEMICONDUCTORS/COMPONENTS,  
Tel. +1 800 234 7381

**China/Hong Kong:** 501 Hong Kong Industrial Technology Centre,  
72 Tat Chee Avenue, Kowloon Tong, HONG KONG,  
Tel. +852 2319 7888, Fax. +852 2319 7700

**Colombia:** see South America

**Czech Republic:** see Austria

**Denmark:** Prags Boulevard 80, PB 1919, DK-2300 COPENHAGEN S,  
Tel. +45 32 88 2636, Fax. +45 31 57 1949

**Finland:** Sinikalliontie 3, FIN-02630 ESPOO,  
Tel. +358 9 615800, Fax. +358 9 61580/xxx

**France:** 4 Rue du Port-aux-Vins, BP317, 92156 SURESNES Cedex,  
Tel. +33 1 40 99 6161, Fax. +33 1 40 99 6427

**Germany:** Hammerbrookstraße 69, D-20097 HAMBURG,  
Tel. +49 40 23 53 60, Fax. +49 40 23 536 300

**Greece:** No. 15, 25th March Street, GR 17778 TAVROS/ATHENS,  
Tel. +30 1 4894 339/239, Fax. +30 1 4814 240

**Hungary:** see Austria

**India:** Philips INDIA Ltd, Shivsagar Estate, A Block, Dr. Annie Besant Rd.  
Worli, MUMBAI 400 018, Tel. +91 22 4938 541, Fax. +91 22 4938 722

**Indonesia:** see Singapore

**Ireland:** Newstead, Clonskeagh, DUBLIN 14,  
Tel. +353 1 7640 000, Fax. +353 1 7640 200

**Israel:** RAPAC Electronics, 7 Kehilat Saloniki St, TEL AVIV 61180,  
Tel. +972 3 645 0444, Fax. +972 3 649 1007

**Italy:** PHILIPS SEMICONDUCTORS, Piazza IV Novembre 3,  
20124 MILANO, Tel. +39 2 6752 2531, Fax. +39 2 6752 2557

**Japan:** Philips Bldg 13-37, Kohnan 2-chome, Minato-ku, TOKYO 108,  
Tel. +81 3 3740 5130, Fax. +81 3 3740 5077

**Korea:** Philips House, 260-199 Itaewon-dong, Yongsan-ku, SEOUL,  
Tel. +82 2 709 1412, Fax. +82 2 709 1415

**Malaysia:** No. 76 Jalan Universiti, 46200 PETALING JAYA, SELANGOR,  
Tel. +60 3 750 5214, Fax. +60 3 757 4880

**Mexico:** 5900 Gateway East, Suite 200, EL PASO, TEXAS 79905,  
Tel. +9-5 800 234 7381

**Middle East:** see Italy

**Netherlands:** Postbus 90050, 5600 PB EINDHOVEN, Bldg. VB,  
Tel. +31 40 27 82785, Fax. +31 40 27 88399

**New Zealand:** 2 Wagener Place, C.P.O. Box 1041, AUCKLAND,  
Tel. +64 9 849 4160, Fax. +64 9 849 7811

**Norway:** Box 1, Manglerud 0612, OSLO,  
Tel. +47 22 74 8000, Fax. +47 22 74 8341

**Philippines:** Philips Semiconductors Philippines Inc.,  
106 Valero St. Salcedo Village, P.O. Box 2108 MCC, MAKATI,  
Metro MANILA, Tel. +63 2 816 6380, Fax. +63 2 817 3474

**Poland:** Ul. Lukiska 10, PL 04-123 WARSZAWA,  
Tel. +48 22 612 2831, Fax. +48 22 612 2327

**Portugal:** see Spain

**Romania:** see Italy

**Russia:** Philips Russia, Ul. Usatcheva 35A, 119048 MOSCOW,  
Tel. +7 095 755 6918, Fax. +7 095 755 6919

**Singapore:** Lorong 1, Toa Payoh, SINGAPORE 1231,  
Tel. +65 350 2538, Fax. +65 251 6500

**Slovakia:** see Austria

**Slovenia:** see Italy

**South Africa:** S.A. PHILIPS Pty Ltd., 195-215 Main Road Martindale,  
2092 JOHANNESBURG, P.O. Box 7430 Johannesburg 2000,  
Tel. +27 11 470 5911, Fax. +27 11 470 5494

**South America:** Rua do Rocio 220, 5th floor, Suite 51,  
04552-903 São Paulo, SÃO PAULO - SP, Brazil,  
Tel. +55 11 821 2333, Fax. +55 11 829 1849

**Spain:** Balmes 22, 08007 BARCELONA,  
Tel. +34 3 301 6312, Fax. +34 3 301 4107

**Sweden:** Kottbygatan 7, Akalla, S-16485 STOCKHOLM,  
Tel. +46 8 632 2000, Fax. +46 8 632 2745

**Switzerland:** Allmendstrasse 140, CH-8027 ZÜRICH,  
Tel. +41 1 488 2686, Fax. +41 1 481 7730

**Taiwan:** Philips Semiconductors, 6F, No. 96, Chien Kuo N. Rd., Sec. 1,  
TAIPEI, Taiwan Tel. +886 2 2134 2870, Fax. +886 2 2134 2874

**Thailand:** PHILIPS ELECTRONICS (THAILAND) Ltd.,  
209/2 Sanpavuth-Bangna Road Prakanong, BANGKOK 10260,  
Tel. +66 2 745 4090, Fax. +66 2 398 0793

**Turkey:** Talatpasa Cad. No. 5, 80640 GÜLTEPE/ISTANBUL,  
Tel. +90 212 279 2770, Fax. +90 212 282 6707

**Ukraine:** PHILIPS UKRAINE, 4 Patrice Lumumba str., Building B, Floor 7,  
252042 KIEV, Tel. +380 44 264 2776, Fax. +380 44 268 0461

**United Kingdom:** Philips Semiconductors Ltd., 276 Bath Road, Hayes,  
MIDDLESEX UB3 5BX, Tel. +44 181 730 5000, Fax. +44 181 754 8421

**United States:** 811 East Arques Avenue, SUNNYVALE, CA 94088-3409,  
Tel. +1 800 234 7381

**Uruguay:** see South America

**Vietnam:** see Singapore

**Yugoslavia:** PHILIPS, Trg N. Pasica 5/v, 11000 BEOGRAD,  
Tel. +381 11 625 344, Fax. +381 11 635 777

**For all other countries apply to:** Philips Semiconductors, Marketing & Sales Communications,  
Building BE-p, P.O. Box 218, 5600 MD EINDHOVEN, The Netherlands, Fax. +31 40 27 24825

**Internet:** <http://www.semiconductors.philips.com>

© Philips Electronics N.V. 1997

SCA53

All rights are reserved. Reproduction in whole or in part is prohibited without the prior written consent of the copyright owner.

The information presented in this document does not form part of any quotation or contract, is believed to be accurate and reliable and may be changed without notice. No liability will be accepted by the publisher for any consequence of its use. Publication thereof does not convey nor imply any license under patent- or other industrial or intellectual property rights.

Printed in The Netherlands

127147/00/02/pp12

Date of release: 1997 Feb 24

Document order number: 9397 750 01818

*Let's make things better.*

**Philips  
Semiconductors**



**PHILIPS**