

DESCRIPTION

The UTC BU208A is a high voltage, high power, high speed switching NPN transistor in a metal envelope, primarily for use in power supply and horizontal deflection circuits of color television receivers.

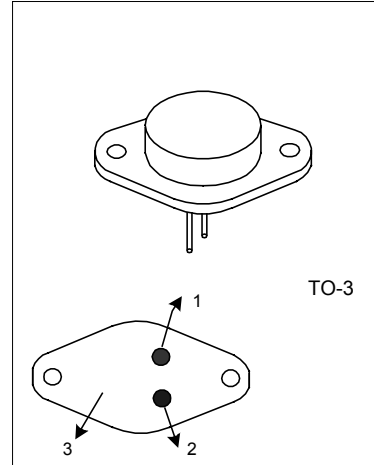

1: Base; 2: Emitter; 3: Collector

QUICK REFERENCE DATA

PARAMETER	SYMBOL	TEST CONDITIONS	MIN	MAX	UNIT
Collector-emitter voltage peak value	V _{CESM}	V _{BE} =0V		1500	V
Collector-emitter voltage (open base)	V _{CEO}			700	V
Collector current (DC)	I _C			8	A
Collector current peak value	I _{CM}			15	A
Total power dissipation	P _D	T _c =25°C		150	W
Collector-emitter saturation voltage	V _{CEsat}	I _c =4.5A; I _B =2.0A		1.0	V
Fall time	t _f	I _c =4.5A, I _{B1} =-1/2 I _{B2} =1.8A, V _{cc} =100V		1.0	μs

LIMITING RATINGS

PARAMETER	SYMBOL	TEST CONDITIONS	MIN	MAX	UNIT
Collector-emitter voltage peak value	V _{CESM}	V _{BE} =0V		1500	V
Collector-emitter voltage (open base)	V _{CEO}			700	V
Collector current (DC)	I _C			8	A
Collector current peak value	I _{CM}			15	A
Base current (DC)	I _B			2	A
Base current peak value	I _{BM}			4	A
Total power dissipation	P _D	T _c =25°C		150	W
Storage temperature	T _{stg}		-55	+150	°C
Junction temperature	T _j			150	°C

UTC BU208A SILICON DIFFUSED POWER TRANSISTOR

ELECTRICAL CHARACTERISTICS

PARAMETER	SYMBOL	TEST CONDITIONS	MIN	MAX	UNIT
Collector-emitter cut-off current	I_{CE}	$V_{BE}=0V, V_{CE}=V_{CESMmax}$		1.0	mA
Collector-emitter cut-off current	I_{CES}	$V_{BE}=0V, V_{CE}=V_{CESMmax}, T_J=125^{\circ}C$		2.0	mA
Collector-emitter saturation voltage	$V_{CE0(SUS)}$	$I_B=0A, I_C=100mA, L=25mH$	700		V
Collector-emitter saturation voltage	V_{CEsat}	$I_C=4.5A, I_B=2.0A$		1.0	V
Base-emitter saturation voltage	V_{BEsat}	$I_C=4.5A, I_B=2.0A$		1.5	V
DC current gain	H_{fe}	$I_C=1A, V_{CE}=5V$	8		
Transition frequency at $f=1MHz$	f_t	$I_C=0.1A, V_{CE}=10V$	3		MHz
Switching times (16KHz line deflection circuit)	t_s			8.0	μs
Turn-off storage time Turn-off fall time	t_f	$I_C=4.5A, I_{B1}=-1/2 I_{B2}=1.8A, V_{CC}=100V$		1.0	μs

UTC assumes no responsibility for equipment failures that result from using products at values that exceed, even momentarily, rated values (such as maximum ratings, operating condition ranges, or other parameters) listed in products specifications of any and all UTC products described or contained herein. UTC products are not designed for use in life support appliances, devices or systems where malfunction of these products can be reasonably expected to result in personal injury. Reproduction in whole or in part is prohibited without the prior written consent of the copyright owner. The information presented in this document does not form part of any quotation or contract, is believed to be accurate and reliable and may be changed without notice.