

## 3.3 V 1:6 LVCMOS PLL Clock Generator

The MPC9331 is a 3.3 V compatible, 1:6 PLL based clock generator targeted for high performance low-skew clock distribution in mid-range to high-performance telecom, networking, and computing applications. With output frequencies up to 240 MHz and output skews less than 150 ps, the device meets the needs of most the demanding clock applications. The MPC9331 is specified for the temperature range of 0°C to +70°C.

### Features

- 1:6 PLL based low-voltage clock generator
- 3.3 V power supply
- Generates clock signals up to 240 MHz
- Maximum output skew of 150 ps
- Differential LVPECL reference clock input
- Alternative LVCMOS PLL reference clock input
- Internal and external PLL feedback
- Supports zero-delay operation in external feedback mode
- PLL multiplies the reference clock by 4x, 3x, 2x, 1x, 4/3x, 3/2x, 2/3x, x/2, x/3 or x/4
- Synchronous output clock stop in logic low eliminates output runt pulses
- Power\_down feature reduces output clock frequency
- Drives up to 12 clock lines
- 32-lead LQFP packaging
- 32-lead Pb-free Package Available
- Ambient temperature range 0°C to +70°C
- Internal Power-Up Reset
- Pin and function compatible to the MPC931

### Functional Description

The MPC9331 utilizes PLL technology to frequency lock its outputs onto an input reference clock. Normal operation of the MPC9331 requires either the selection of internal PLL feedback or the connection of one of the device outputs to the feedback input to close the PLL feedback path in external feedback mode. The reference clock frequency and the divider for the feedback path determine the VCO frequency. Both must be selected to match the VCO frequency range. In external PLL feedback configuration and with the available post-PLL dividers (divide-by-2, divide-by-4, and divide-by-6), the internal VCO of the MPC9331 is running at either 2x, 4x, 6x, 8x, or 12x of the reference clock frequency. In internal feedback configuration (divide-by-8) the internal VCO is running 8x of the reference frequency. The frequency of the QA, QB, QC output banks is a division of the VCO frequency and can be configured independently for each output bank using the FSELA, FSELB, and FSEL pins, respectively. The available output to input frequency ratios are 4x, 3x, 2x, 1x, 4/3x, 3/2x, 2/3x, x/2, x/3, or x/4.

The REF\_SEL pin selects the differential LVPECL or the LVCMOS compatible input as the reference clock signal. The PLL\_EN control selects the PLL bypass configuration for test and diagnosis. In this configuration, the selected input reference clock is routed directly to the output dividers bypassing the PLL. The PLL bypass is fully static and the minimum clock frequency specification and all other PLL characteristics do not apply. The outputs can be disabled (high-impedance) by deasserting the OE/MR pin. In the PLL configuration with external feedback selected, deasserting OE/MR causes the PLL to loose lock due to missing feedback signal presence at FB\_IN. Asserting OE/MR will enable the outputs and close the phase locked loop, enabling the PLL to recover to normal operation. The MPC9331 output clock stop control allows the outputs to start and stop synchronously in logic low state, without the potential generation of runt pulses.

The MPC9331 is fully 3.3 V compatible and requires no external loop filter components. The inputs (except PCLK) accept LVCMOS except signals while the outputs provide LVCMOS compatible levels with the capability to drive terminated 50 Ω transmission lines. For series terminated transmission lines, each of the MPC9331 outputs can drive one or two traces giving the devices an effective fanout of 1:12. The device is packaged in a 7x7 mm<sup>2</sup> 32-lead LQFP package.

**MPC9331**

**LOW VOLTAGE  
3.3 V LVCMOS 1:6  
CLOCK GENERATOR**



**FA SUFFIX  
32-LEAD LQFP PACKAGE  
CASE 873A-03**



**AC SUFFIX  
32-LEAD LQFP PACKAGE  
Pb-FREE PACKAGE  
CASE 873A-03**

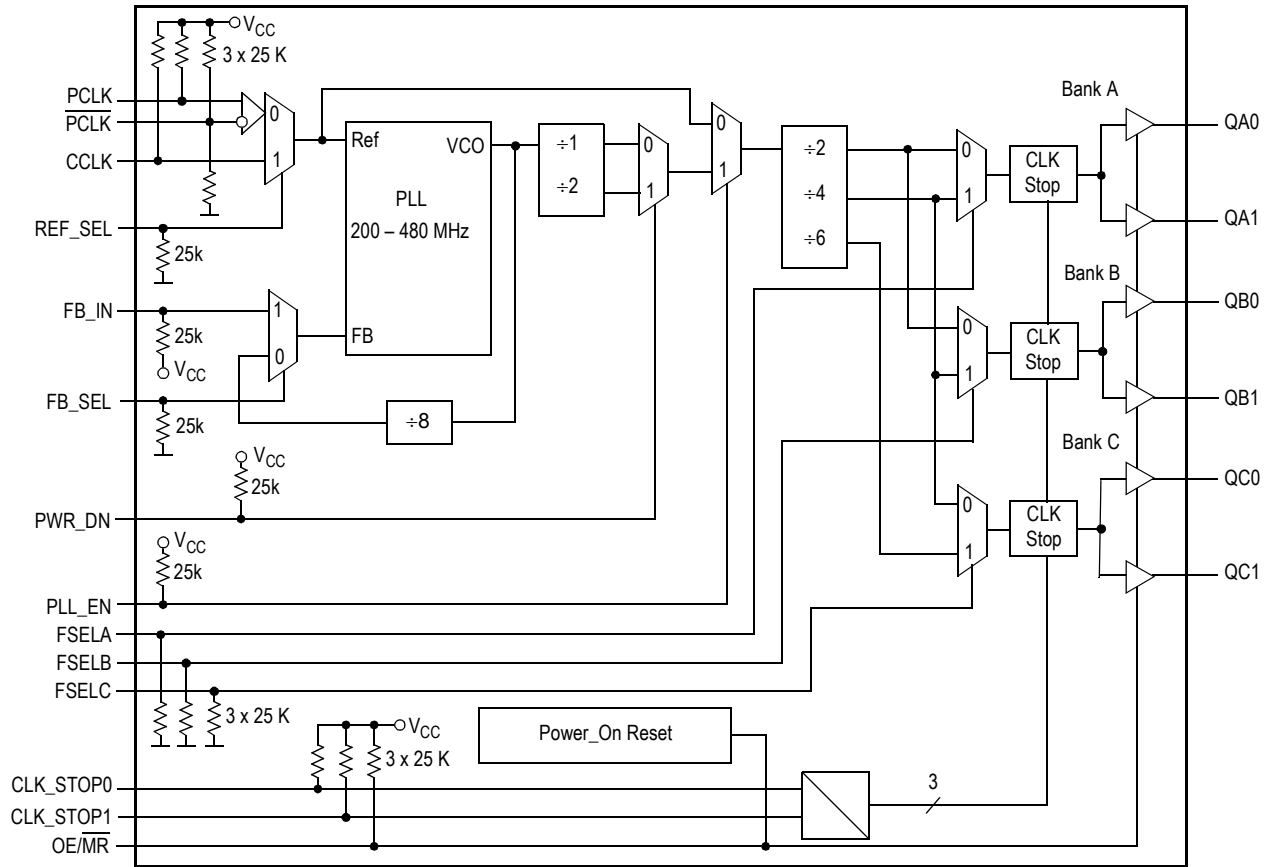
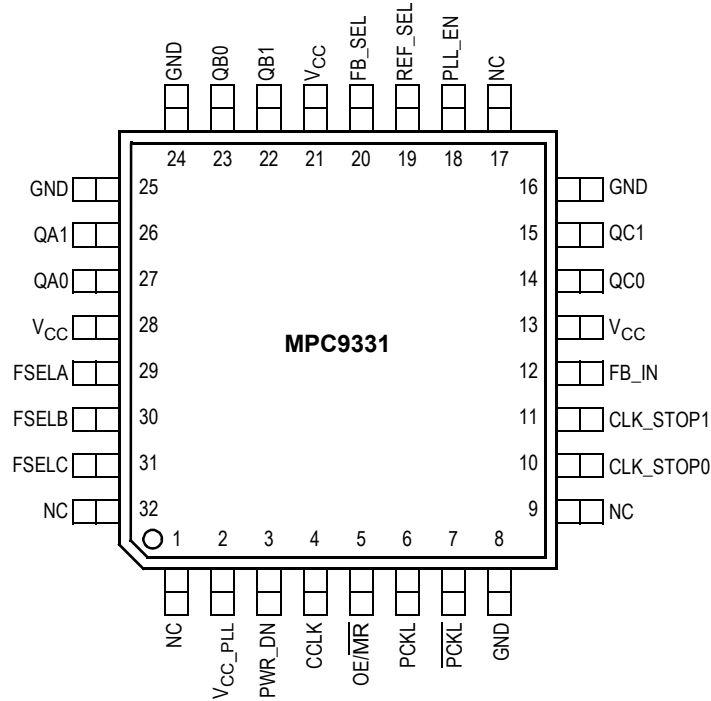


Figure 1. MPC9331 Logic Diagram



It is recommended to use an external RC filter for the analog  $V_{CC\_PLL}$  power supply pin. Please see application section for details.

Figure 2. MPC9331 32-Lead Package Pinout (Top View)

**Table 1. Pin Configuration**

Pin	I/O	Type	Function
CCLK	Input	LVC MOS	PLL reference clock signal
PCLK, PCLK	Input	LVPECL	Differential PECL reference clock signal
FB_IN	Input	LVC MOS	PLL feedback signal input, connect to an output
FB_SEL	Input	LVC MOS	Feedback select
REF_SEL	Input	LVC MOS	Reference clock select
PWR_DN	Input	LVC MOS	Output frequency and power down select
FSELA	Input	LVC MOS	Frequency divider select for bank A outputs
FSELB	Input	LVC MOS	Frequency divider select for bank B outputs
FSELC	Input	LVC MOS	Frequency divider select for bank C outputs
PLL_EN	Input	LVC MOS	PLL enable/disable
CLK_STOP0-1	Input	LVC MOS	Clock output enable/disable
OE/MR	Input	LVC MOS	Output enable/disable (high-impedance tristate) and device reset
QA0-1, QB0-1, QC0-1	Output	LVC MOS	Clock outputs
GND	Supply	Ground	Negative power supply (GND)
V <sub>CC</sub> _PLL	Supply	V <sub>CC</sub>	PLL positive power supply (analog power supply). It is recommended to use external RC filter for the analog power supply pin V <sub>CC</sub> _PLL. Please see applications section for details.
V <sub>CC</sub>	Supply	V <sub>CC</sub>	Positive power supply for I/O and core. All V <sub>CC</sub> pins must be connected to the positive power supply for correct operation

**Table 2. Function Table**

Control	Default	0	1
REF_SEL	0	PCLK is the PLL reference clock	CCLK is the PLL reference clock
FB_SEL	1	Internal PLL feedback of 8. $f_{VCO} = 8 * f_{ref}$	External feedback. Zero-delay operation enabled for CCLK or PCLK as reference clock
PLL_EN	1	Test mode with PLL disabled. The reference clock is substituted for the internal VCO output. MPC9331 is fully static and no minimum frequency limit applies. All PLL related AC characteristics are not applicable.	Normal operation mode with PLL enabled.
PWR_DN	1	VCO ÷ 1 (High output frequency range)	VCO ÷ 2 (Low output frequency range)
FSELA	0	Output divider ÷ 2	Output divider ÷ 4
FSELB	0	Output divider ÷ 2	Output divider ÷ 4
FSELC	0	Output divider ÷ 4	Output divider ÷ 6
OE/MR	1	Outputs disabled (high-impedance state) and reset of the device. During reset in external feedback configuration, the PLL feedback loop is open. The VCO is tied to its lowest frequency. The MPC9331 requires reset after any loss of PLL lock. Loss of PLL lock may occur when the external feedback path is interrupted. The length of the reset pulse should be greater than one reference clock cycle (CCLK or PCLK). Reset does not affect PLL lock in internal feedback configuration.	Outputs enabled (active)
CLK_STOP[0:1]	11	See <a href="#">Table 3</a>	

PWR\_DN, FSELA, FSELB and FSELC control the operating PLL frequency range and input/output frequency ratios. See [Table 8](#) through [Table 10](#) for supported frequency ranges and output to input frequency ratios.

**Table 3. Clock Output Synchronous Disable (CLK\_STOP) Function Table<sup>(1)</sup>**

CLK_STOP0	CLK_STOP1	QA[0:1]	QB[0:1]	QC[0:1]
0	0	Active	Stopped in logic L state	Stopped in logic L state
0	1	Active	Stopped in logic L state	Active
1	0	Stopped in logic L state	Stopped in logic L state	Active
1	1	Active	Active	Active

1. Output operation for  $\overline{OE}/\overline{MR}=1$  (outputs enabled).  $\overline{OE}/\overline{MR}=0$  will disable (high-impedance state) all outputs independent on CLK\_STOP[0:1].

**Table 4. General Specifications**

Symbol	Characteristics	Min	Typ	Max	Unit	Condition
V <sub>TT</sub>	Output Termination Voltage		V <sub>CC</sub> ÷ 2		V	
MM	ESD Protection (Machine Model)	200			V	
HBM	ESD Protection (Human Body Model)	2000			V	
LU	Latch-Up Immunity	200			mA	
C <sub>PD</sub>	Power Dissipation Capacitance		10		pF	Per output
C <sub>IN</sub>	Input Capacitance		4.0		pF	Inputs

**Table 5. Absolute Maximum Ratings<sup>(1)</sup>**

Symbol	Characteristics	Min	Max	Unit	Condition
V <sub>CC</sub>	Supply Voltage	-0.3	3.9	V	
V <sub>IN</sub>	DC Input Voltage	-0.3	V <sub>CC</sub> + 0.3	V	
V <sub>OUT</sub>	DC Output Voltage	-0.3	V <sub>CC</sub> + 0.3	V	
I <sub>IN</sub>	DC Input Current		±20	mA	
I <sub>OUT</sub>	DC Output Current		±50	mA	
T <sub>S</sub>	Storage Temperature	-65	125	°C	

1. Absolute maximum continuous ratings are those maximum values beyond which damage to the device may occur. Exposure to these conditions or conditions beyond those indicated may adversely affect device reliability. Functional operation at absolute-maximum-rated conditions is not implied.

**Table 6. DC Characteristics (V<sub>CC</sub> = 3.3 V ± 5%, T<sub>A</sub> = 0°C to 70°C)**

Symbol	Characteristics	Min	Typ	Max	Unit	Condition
V <sub>IH</sub>	Input high voltage	2.0		V <sub>CC</sub> + 0.3	V	LVC MOS
V <sub>IL</sub>	Input low voltage			0.8	V	LVC MOS
V <sub>PP</sub>	Peak-to-peak input voltage PCLK, $\overline{PCLK}$	250			mV	LVPECL
V <sub>CMR</sub> <sup>(1)</sup>	Common Mode Range PCLK, $\overline{PCLK}$	1.0		V <sub>CC</sub> - 0.6	V	LVPECL
V <sub>OH</sub>	Output High Voltage	2.4			V	I <sub>OH</sub> = -24 mA <sup>(2)</sup>
V <sub>OL</sub>	Output Low Voltage			0.55 0.30	V V	I <sub>OL</sub> = 24 mA I <sub>OL</sub> = 12 mA
Z <sub>OUT</sub>	Output impedance		14 - 17		Ω	
I <sub>IN</sub>	Input Current <sup>(3)</sup>			±200	μA	V <sub>IN</sub> = V <sub>CC</sub> or GND
I <sub>CC_PLL</sub>	Maximum PLL Supply Current		8.0	12	mA	V <sub>CC_PLL</sub> Pin
I <sub>CCQ</sub>	Maximum Quiescent Supply Current <sup>(4)</sup>			26	mA	All V <sub>CC</sub> Pins

- V<sub>CMR</sub> (DC) is the crosspoint of the differential input signal. Functional operation is obtained when the crosspoint is within the V<sub>CMR</sub> range and the input swing lies within the V<sub>PP</sub> (DC) specification.
- The MPC9331 is capable of driving 50 Ω transmission lines on the incident edge. Each output drives one 50 Ω parallel terminated transmission line to a termination voltage of V<sub>TT</sub>. Alternatively, the device drives up to two 50 Ω series terminated transmission lines.
- Inputs have pull-down or pull-up resistors affecting the input current.
- $\overline{OE}/\overline{MR}=0$  (outputs in high-impedance state).

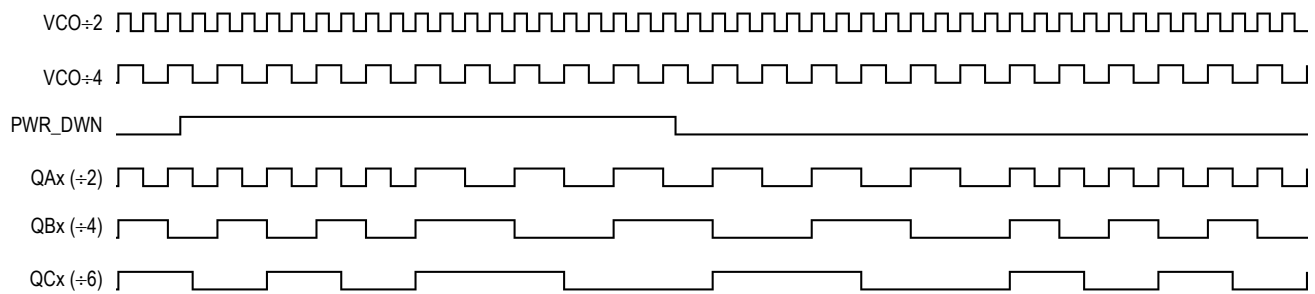
**Table 7. AC Characteristics** ( $V_{CC} = 3.3V \pm 5\%$ ,  $T_A = 0^\circ C$  to  $70^\circ C$ )<sup>(1)</sup>

Symbol	Characteristics	Min	Typ	Max	Unit	Condition	
$f_{REF}$	Input reference frequency PLL mode, external feedback  PLL mode, internal feedback Input reference frequency in PLL bypass mode <sup>(2)</sup>	$\div 2$ feedback	100.0		240.0	MHz	PLL locked
		$\div 4$ feedback	50.0		120.0	MHz	
		$\div 6$ feedback	33.3		80.0	MHz	
		$\div 8$ feedback	25.0		60.0	MHz	
		$\div 12$ feedback	16.67		40.0	MHz	
		( $\div 8$ feedback)	25.0		60.0	MHz	
$f_{VCO}$	VCO lock frequency range <sup>(3)</sup>	200		480	MHz		
$f_{MAX}$	Output Frequency	$\div 2$ output	100.0		240.0	MHz	PLL locked
		$\div 4$ output	50.0		120.0	MHz	
		$\div 6$ output	33.3		80.0	MHz	
		$\div 8$ output	25.0		60.0	MHz	
		$\div 12$ output	16.67		40.0	MHz	
$V_{PP}$	Peak-to-peak input voltage	PCLK, $\overline{PCLK}$	400		1000	mV	LVPECL
$V_{CMR}$ <sup>(4)</sup>	Common Mode Range	PCLK, $\overline{PCLK}$	1.2		$V_{CC} - 0.9$	V	LVPECL
$t_{PW,MIN}$	Input Reference Pulse Width <sup>(5)</sup>		2.0			ns	
$t_R, t_F$	CCLK Input Rise/Fall Time <sup>(6)</sup>				1.0	ns	0.8 to 2.0 V
$t_{(\varnothing)}$	Propagation Delay (static phase offset)	CCLK to FB_IN <sup>(7)</sup>	-250	-130	-50	ps	FB_SEL = 1 and PLL locked
		PCLK to FB_IN <sup>(7)</sup>	-180	-30	+120	ps	
		CCLK or PCLK to FB_IN <sup>(8)</sup>	-3.0		+3.0	°	
$t_{sk(O)}$	Output-to-output Skew				150	ps	
DC	Output duty cycle <sup>(9)</sup>	(T $\div$ 2)-500	T $\div$ 2	(T $\div$ 2)+500		ps	
$t_R, t_F$	Output Rise/Fall Time	0.1		1.0		ns	0.55 to 2.4 V
$t_{PLZ, HZ}$	Output Disable Time			8.0		ns	
$t_{PZL, LZ}$	Output Enable Time			10		ns	
$t_{JIT(CC)}$	Cycle-to-cycle jitter <sup>(10)</sup>			200		ps	
$t_{JIT(PER)}$	Period Jitter			125		ps	
$t_{JIT(\varnothing)}$	I/O Phase Jitter	RMS (1 $\sigma$ )		25		ps	
BW	PLL closed loop bandwidth <sup>(11)</sup> PLL mode, external feedback	$\div 4$ feedback		2.0-8.0		MHz	
		$\div 6$ feedback		1.2-4.0		MHz	
		$\div 8$ feedback		1.0-3.0		MHz	
		$\div 12$ feedback		0.7-2.0		MHz	
$t_{LOCK}$	Maximum PLL Lock Time			10		ms	

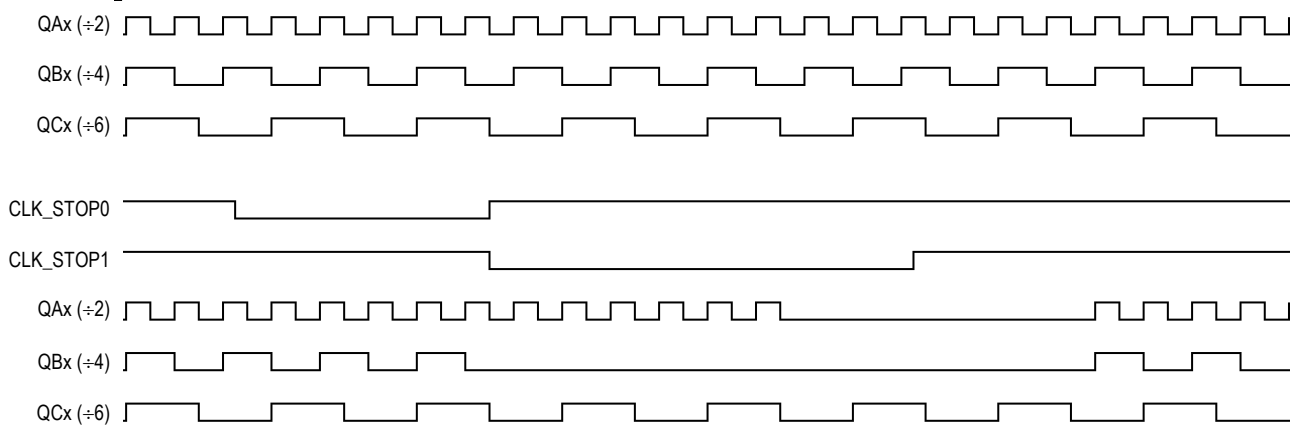
- AC characteristics apply for parallel output termination of 50  $\Omega$  to  $V_{TT}$ .
- In bypass mode, the MPC9331 divides the input reference clock.
- The input frequency  $f_{REF}$  must match the VCO frequency range divided by the feedback divider ratio FB:  $f_{REF} = f_{VCO} \div FB$ .
- $V_{CMR}$  (AC) is the crosspoint of the differential input signal. Normal AC operation is obtained when the crosspoint is within the  $V_{CMR}$  range and the input swing lies within the  $V_{PP}$  (AC) specification. Violation of  $V_{CMR}$  or  $V_{PP}$  impacts static phase offset  $t_{(\varnothing)}$ .
- Calculation of reference duty cycle limits:  $DC_{REF,MIN} = t_{PW,MIN} \cdot f_{REF} \cdot 100\%$  and  $DC_{REF,MAX} = 100\% - DC_{REF,MIN}$ .
- The MPC9331 will operate with input rise/fall times up to 3.0 ns, but the AC characteristics, specifically  $t_{(\varnothing)}$ ,  $t_{PW,MIN}$ , DC and  $f_{MAX}$  can only be guaranteed if  $t_R, t_F$  are within the specified range.
- Data valid for  $f_{REF} = 50$  MHz and a PLL feedback of  $\div 8$  (e.g. QAx connected to FB\_IN and FSELA=1, PWR\_DN=1).
- Data valid for 16.67 MHz <  $f_{REF}$  < 100 MHz and any feedback divider.  $t_{sk(O)} [s] = t_{sk(O)} [^\circ] \div (f_{REF} \cdot 360^\circ)$ .
- Output duty cycle is DC =  $(0.5 \pm 500 \text{ ps} \cdot f_{OUT}) \cdot 100\%$ . (e.g. the DC range at  $f_{OUT} = 100$  MHz is 45% < DC < 55%).
- All outputs in  $\div 4$  divider configuration.
- 3 dB point of PLL transfer characteristics.

## APPLICATIONS INFORMATION

### Output Power Down (PWR\_DN) Timing Diagram



### Output Clock Stop (CLK\_STOP) Timing Diagram



### Programming the MPC9331

The MPC9331 supports output clock frequencies from 16.67 to 240 MHz. Different feedback and output divider configurations can be used to achieve the desired input to output frequency relationship. The feedback frequency and divider should be used to situate the VCO in the frequency lock range between 200 and 480 MHz for stable and optimal operation. The FSELA, FSELB, FSELC and PWR\_DN pins

select the desired output clock frequencies. Possible frequency ratios of the reference clock input to the outputs are 4:1, 3:1, 2:1, 1:1, 1:2, 2:3 and 3:2. [Table 8](#) illustrates the various output configurations and frequency ratios supported by the MPC9331. See also [Table 9](#) and [Table 10](#) for further reference.

**Table 8. MPC9331 Example Configurations (Internal Feedback: FB\_SEL = 0)**

fref <sup>(1)</sup> [MHz]	PWR_DN	FSELA	FSELB	FSELC	QA[0:1]:fref ratio	QB[0:1]:fref ratio	QC[0:1]:fref ratio
25.0 – 60.0	0	0	0	0	fref · 4 (100-240 MHz)	fref · 4 (100-240 MHz)	fref · 2 (50-120 MHz)
	0	0	0	1	fref · 4 (100-240 MHz)	fref · 4 (100-240 MHz)	fref · 4÷3 (33.3-80 MHz)
	0	0	1	0	fref · 4 (100-240 MHz)	fref · 2 (50-120 MHz)	fref · 2 (50-120 MHz)
	0	0	1	1	fref · 4 (100-240 MHz)	fref · 2 (50-120 MHz)	fref · 4÷3 (33.3-80 MHz)
	0	1	0	0	fref · 2 (50-120 MHz)	fref · 4 (100-240 MHz)	fref · 2 (50-120 MHz)
	0	1	0	1	fref · 2 (50-120 MHz)	fref · 4 (100-240 MHz)	fref · 4÷3 (33.3-80 MHz)
	0	1	1	0	fref · 2 (50-120 MHz)	fref · 2 (50-120 MHz)	fref · 2 (50-120 MHz)
	0	1	1	1	fref · 2 (50-120 MHz)	fref · 2 (50-120 MHz)	fref · 4÷3 (33.3-80 MHz)
	1	0	0	0	fref · 2 (50-120 MHz)	fref · 2 (50-120 MHz)	fref (25.0-60 MHz)
	1	0	0	1	fref · 2 (50-120 MHz)	fref · 2 (50-120 MHz)	fref · 2÷3 (16.67-40 MHz)
	1	0	1	0	fref · 2 (50-120 MHz)	fref (25.0-60 MHz)	fref (25.0-60 MHz)
	1	0	1	1	fref · 2 (50-120 MHz)	fref (25.0-60 MHz)	fref · 2÷3 (16.67-40 MHz)
	1	1	0	0	fref (25.0-60 MHz)	fref · 2 (50-120 MHz)	fref (25.0-60 MHz)
	1	1	0	1	fref (25.0-60 MHz)	fref · 2 (50-120 MHz)	fref · 2÷3 (16.67-40 MHz)
1	1	1	0	fref (25.0-60 MHz)	fref (25.0-60 MHz)	fref (25.0-60 MHz)	
1	1	1	1	fref (25.0-60 MHz)	fref (25.0-60 MHz)	fref · 2÷3 (16.67-40 MHz)	

1. fref is the input clock reference frequency (CCLK or PCLK).

**Table 9. MPC9331 Example Configurations (External Feedback and PWR\_DN = 0)**

PLL Feedback	fref <sup>(1)</sup> [MHz]	FSELA	FSELB	FSELC	QA[0:1]:fref ratio	QB[0:1]:fref ratio	QC[0:1]:fref ratio
VCO ÷ 2 <sup>(2)</sup>	100 – 240	0	0	0	fref (100-240 MHz)	fref (100-240 MHz)	fref ÷ 2 (50-120 MHz)
		0	0	1	fref (100-240 MHz)	fref (100-240 MHz)	fref ÷ 3 (33.3-80 MHz)
		0	1	0	fref (100-240 MHz)	fref ÷ 2 (50-120 MHz)	fref ÷ 2 (50-120 MHz)
		0	1	1	fref (100-240 MHz)	fref ÷ 2 (50-120 MHz)	fref ÷ 3 (33.3-80 MHz)
VCO ÷ 4 <sup>(3)</sup>	50 – 120	1	0	0	fref (50-120 MHz)	fref · 2 (100-240 MHz)	fref (50-120 MHz)
		1	0	1	fref (50-120 MHz)	fref · 2 (100-240 MHz)	fref · 2÷3 (33.3-80 MHz)
		1	1	0	fref (50-120 MHz)	fref (100-240 MHz)	fref (50-120 MHz)
		1	1	1	fref (50-120 MHz)	fref (100-240 MHz)	fref · 2 ÷ 3 (33.3-80 MHz)
VCO ÷ 6 <sup>(4)</sup>	33.3 – 80	0	0	1	fref · 3 (100-240 MHz)	fref · 3 (100-240 MHz)	fref (33.3-80 MHz)
		0	1	1	fref · 3 (100-240 MHz)	fref · 3 ÷ 2 (50-120 MHz)	fref (33.3-80 MHz)
		1	0	1	fref · 3 ÷ 2 (50-120 MHz)	fref · 3 (100-240 MHz)	fref (33.3-80 MHz)
		1	1	1	fref · 3 ÷ 2 (50-120 MHz)	fref · 3 ÷ 2 (50-120 MHz)	fref (33.3-80 MHz)

1. fref is the input clock reference frequency (CCLK or PCLK).

2. QAx connected to FB\_IN and FSELA=0, PWR\_DN=0.

3. QAx connected to FB\_IN and FSELA=1, PWR\_DN=0.

4. QCx connected to FB\_IN and FSELC=1, PWR\_DN=0.

**Table 10. MPC9331 Example Configurations (External Feedback and PWR\_DN = 1)**

PLL Feedback	fref <sup>(1)</sup> [MHz]	FSELA	FSELB	FSELC	QA[0:1]:fref ratio	QB[0:1]:fref ratio	QC[0:1]:fref ratio
VCO ÷ 8 <sup>(2)</sup>	25.0 – 60.0	1	0	0	fref (25-60 MHz)	fref · 2 (50-120 MHz)	fref (2.25-60 MHz)
		1	0	1	fref (25-60 MHz)	fref · 2 (50-120 MHz)	fref · 2÷3 (16.6-40 MHz)
		1	1	0	fref (25-60 MHz)	fref (25-60 MHz)	fref (25-60 MHz)
		1	1	1	fref (25-60 MHz)	fref (25-60 MHz)	fref · 2÷3 (16.6-40 MHz)
VCO ÷ 12 <sup>(3)</sup>	16.67 – 40	0	0	1	fref · 3 (50-120 MHz)	fref · 3 (50-120 MHz)	fref (16.67-40 MHz)
		0	1	1	fref · 3 (50-120 MHz)	fref · 3 ÷ 2 (25-60 MHz)	fref (16.67-40 MHz)
		1	0	1	fref · 3 ÷ 2 (25-60 MHz)	fref · 3 (50-120 MHz)	fref (16.67-40 MHz)
		1	1	1	fref · 3 ÷ 2 (25-60 MHz)	fref · 3 ÷ 2 (25-60 MHz)	fref (16.67-40 MHz)

1. fref is the input clock reference frequency (CCLK or PCLK).

2. QAx connected to FB\_IN and FSELA=1, PWR\_DN=1.

3. QCx connected to FB\_IN and FSELC=1, PWR\_DN=1.

## APPLICATIONS INFORMATION

### Power Supply Filtering

The MPC9331 is a mixed analog/digital product. Its analog circuitry is naturally susceptible to random noise, especially if this noise is seen on the power supply pins. Random noise on the  $V_{CC\_PLL}$  power supply impacts the device characteristics, for instance, I/O jitter. The MPC9331 provides separate power supplies for the output buffers ( $V_{CC}$ ) and the phase-locked loop ( $V_{CC\_PLL}$ ) of the device. The purpose of this design technique is to isolate the high switching noise digital outputs from the relatively sensitive internal analog phase-locked loop. In a digital system environment where it is more difficult to minimize noise on the power supplies, a second level of isolation may be required. The simple but effective form of isolation is a power supply filter on the  $V_{CC\_PLL}$  pin for the MPC9331. Figure 3 illustrates a typical power supply filter scheme. The MPC9331 frequency and phase stability is most susceptible to noise with spectral content in the 100 kHz to 20 MHz range. Therefore the filter should be designed to target this range. The key parameter that needs to be met in the final filter design is the DC voltage drop across the series filter resistor  $R_F$ . From the data sheet, the  $I_{CC\_PLL}$  current (the current sourced through the  $V_{CC\_PLL}$  pin) is typically 8 mA (12 mA maximum), assuming that a minimum of 3.0 V must be maintained on the  $V_{CC\_PLL}$  pin.

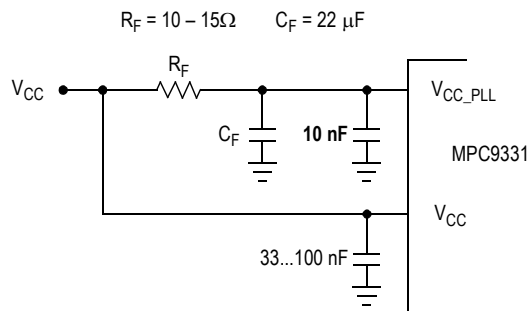


Figure 3.  $V_{CC\_PLL}$  Power Supply Filter

The minimum values for  $R_F$  and the filter capacitor  $C_F$  are defined by the required filter characteristics: the RC filter should provide an attenuation greater than 40 dB for noise whose spectral content is above 100 kHz. In the example RC filter shown in Figure 3, the filter cut-off frequency is around 3-5 kHz and the noise attenuation at 100 kHz is better than 42 dB.

As the noise frequency crosses the series resonant point of an individual capacitor its overall impedance begins to look inductive and thus increases with increasing frequency. The parallel capacitor combination shown ensures that a low impedance path to ground exists for frequencies well above the bandwidth of the PLL. Although the MPC9331 has several design features to minimize the susceptibility to power supply noise (isolated power and grounds and fully differential PLL) there still may be applications in which overall performance is being degraded due to system power supply noise. The power supply filter schemes discussed in this section should be adequate to eliminate power supply noise related problems in most designs.

### Driving Transmission Lines

The MPC9331 clock driver was designed to drive high-speed signals in a terminated transmission line environment. To provide the optimum flexibility to the user, the output drivers were designed to exhibit the lowest impedance possible. With an output impedance of less than 20  $\Omega$ , the drivers can drive either parallel or series terminated transmission lines. For more information on transmission lines, the reader is referred to Freescale application note AN1091. In most high performance clock networks, point-to-point distribution of signals is the method of choice. In a point-to-point scheme, either series terminated or parallel terminated transmission lines can be used. The parallel technique terminates the signal at the end of the line with a 50  $\Omega$  resistance to  $V_{CC}/2$ .

This technique draws a fairly high level of DC current and thus only a single terminated line can be driven by each output of the MPC9331 clock driver. For the series terminated case, however, there is no DC current draw, thus the outputs can drive multiple series terminated lines. Figure 4 illustrates an output driving a single series terminated line versus two series terminated lines in parallel. When taken to its extreme the fanout of the MPC9331 clock driver is effectively doubled due to its capability to drive multiple lines.

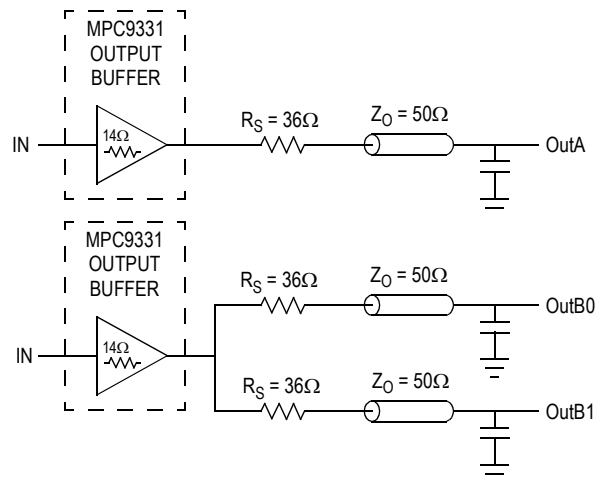


Figure 4. Single versus Dual Transmission Lines

The waveform plots in Figure 5 show the simulation results of an output driving a single line versus two lines. In both cases, the drive capability of the MPC9331 output buffer is more than sufficient to drive 50  $\Omega$  transmission lines on the incident edge. Note from the delay measurements in the simulations, a delta of only 43 ps exists between the two differently loaded outputs. This suggests that the dual line driving need not be used exclusively to maintain the tight output-to-output skew of the MPC9331. The output waveform in Figure 5 shows a step in the waveform; this step is caused by the impedance mismatch seen looking into the driver. The parallel combination of the 36  $\Omega$  series resistor plus the output impedance does not match the parallel combination of the line impedances. The voltage wave launched down the two lines will equal:

$$V_L = V_S (Z_0 \div (R_S + R_0 + Z_0))$$

$$Z_0 = 50 \Omega \parallel 50 \Omega$$

$$R_S = 36 \Omega \parallel 36 \Omega$$

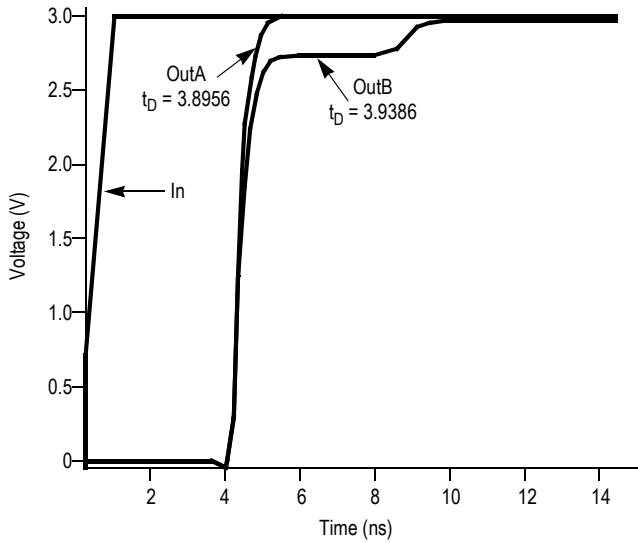
$$R_0 = 14 \Omega$$

$$V_L = 3.0 (25 \div (18 + 14 + 25))$$

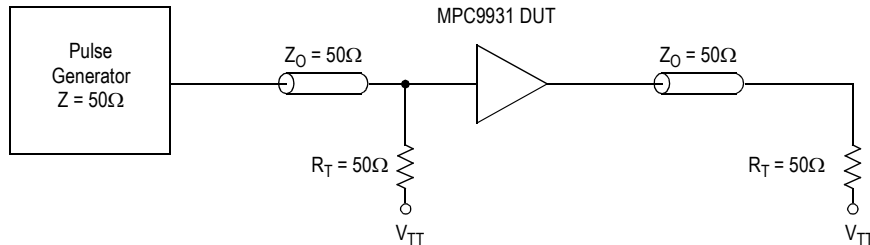
$$= 1.31 \text{ V}$$

At the load end, the voltage will double due to the near unity reflection coefficient, to 2.6 V. It will then increment towards the quiescent 3.0 V in steps separated by one round trip delay (in this case 4.0 ns).

1. Final skew data pending specification.

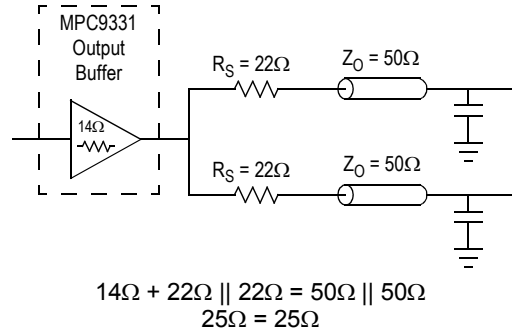


**Figure 5. Single versus Dual Line Termination Waveforms**

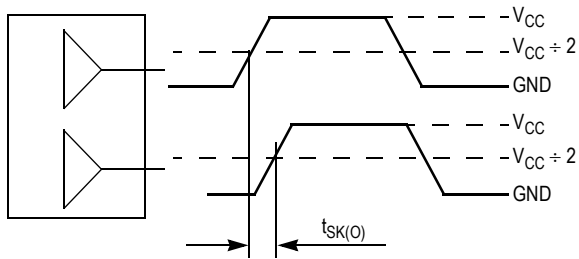


**Figure 7. CCLK MPC9331 AC Test Reference for  $V_{CC} = 3.3 \text{ V}$**

Since this step is well above the threshold region it will not cause any false clock triggering; however, designers may be uncomfortable with unwanted reflections on the line. To better match the impedances when driving multiple lines, the situation in should be used. In this case the series terminating resistors are reduced such that when the parallel combination is added to the output buffer impedance, the line impedance is perfectly matched.

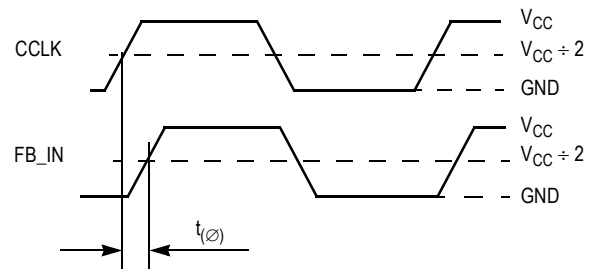


**Figure 6. Optimized Dual Line Termination**

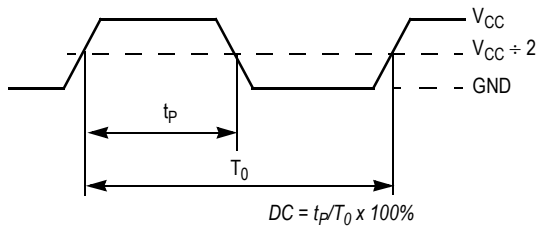


The pin-to-pin skew is defined as the worst case difference in propagation delay between any similar delay path within a single device

**Figure 8. Output-to-Output Skew  $t_{sk(O)}$**

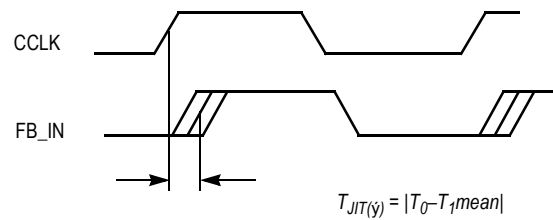


**Figure 9. Propagation Delay ( $t_{\phi}$ , Static Phase offset) Test Reference**



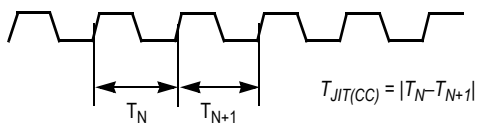
The time from the PLL controlled edge to the non controlled edge, divided by the time between PLL controlled edges, expressed as a percentage

**Figure 10. Output Duty Cycle (DC)**



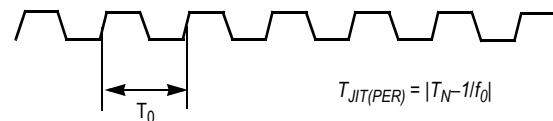
The deviation in  $t_0$  for a controlled edge with respect to a  $t_0$  mean in a random sample of cycles

**Figure 11. I/O Jitter**



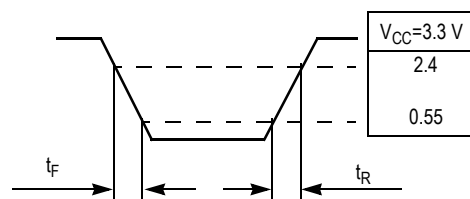
The variation in cycle time of a signal between adjacent cycles, over a random sample of adjacent cycle pairs

**Figure 12. Cycle-to-Cycle Jitter**



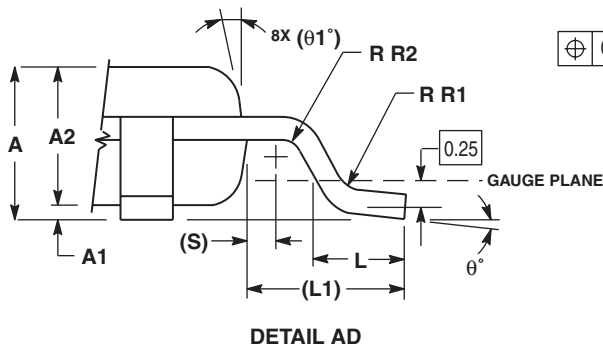
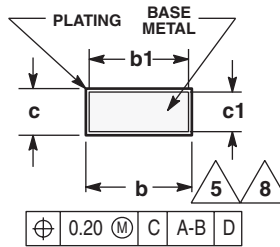
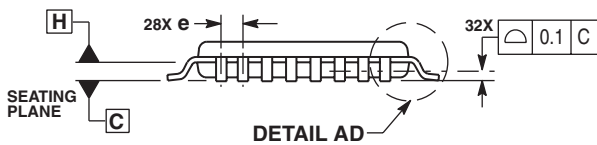
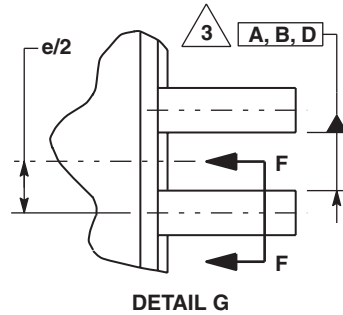
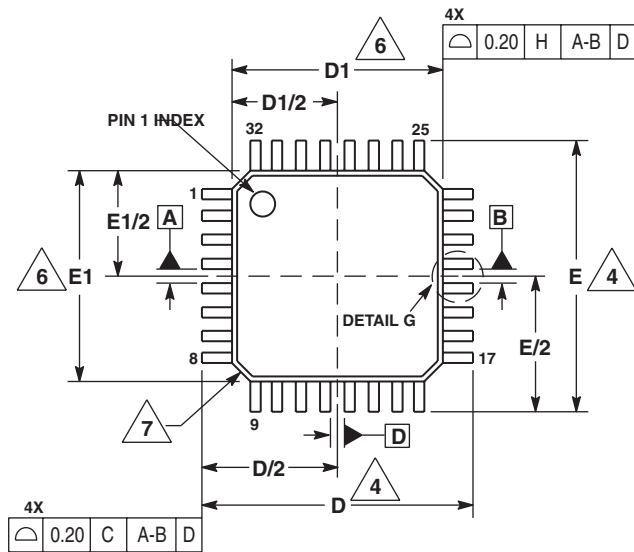
The deviation in cycle time of a signal with respect to the ideal period over a random sample of cycles

**Figure 13. Period Jitter**



**Figure 14. Output Transition Time Test Reference**

# PACKAGE DIMENSIONS



- NOTES:
1. DIMENSIONS ARE IN MILLIMETERS.
  2. INTERPRET DIMENSIONS AND TOLERANCES PER ASME Y14.5M, 1994.
  3. DATUMS A, B, AND D TO BE DETERMINED AT DATUM PLANE H.
  4. DIMENSIONS D AND E TO BE DETERMINED AT SEATING PLANE C.
  5. DIMENSION b DOES NOT INCLUDE DAMBAR PROTRUSION. ALLOWABLE DAMBAR PROTRUSION SHALL NOT CAUSE THE LEAD WIDTH TO EXCEED THE MAXIMUM b DIMENSION BY MORE THAN 0.08-mm. DAMBAR CANNOT BE LOCATED ON THE LOWER RADIUS OR THE FOOT. MINIMUM SPACE BETWEEN PROTRUSION AND ADJACENT LEAD OR PROTRUSION: 0.07-mm.
  6. DIMENSIONS D1 AND E1 DO NOT INCLUDE MOLD PROTRUSION. ALLOWABLE PROTRUSION IS 0.25-mm PER SIDE. D1 AND E1 ARE MAXIMUM PLASTIC BODY SIZE DIMENSIONS INCLUDING MOLD MISMATCH.
  7. EXACT SHAPE OF EACH CORNER IS OPTIONAL.
  8. THESE DIMENSIONS APPLY TO THE FLAT SECTION OF THE LEAD BETWEEN 0.1-mm AND 0.25-mm FROM THE LEAD TIP.

DIM	MILLIMETERS	
	MIN	MAX
A	1.40	1.60
A1	0.05	0.15
A2	1.35	1.45
b	0.30	0.45
b1	0.30	0.40
c	0.09	0.20
c1	0.09	0.16
D	9.00	BSC
D1	7.00	BSC
e	0.80	BSC
E	9.00	BSC
E1	7.00	BSC
L	0.50	0.70
L1	1.00	REF
q	0°	7°
q1	12	REF
R1	0.08	0.20
R2	0.08	---
S	0.20	REF

## CASE 873A-03 ISSUE B 32-LEAD LQFP PACKAGE

## **How to Reach Us:**

### **Home Page:**

[www.freescale.com](http://www.freescale.com)

### **E-mail:**

[support@freescale.com](mailto:support@freescale.com)

### **USA/Europe or Locations Not Listed:**

Freescale Semiconductor  
Technical Information Center, CH370  
1300 N. Alma School Road  
Chandler, Arizona 85224  
+1-800-521-6274 or +1-480-768-2130  
[support@freescale.com](mailto:support@freescale.com)

### **Europe, Middle East, and Africa:**

Freescale Halbleiter Deutschland GmbH  
Technical Information Center  
Schatzbogen 7  
81829 Muenchen, Germany  
+44 1296 380 456 (English)  
+46 8 52200080 (English)  
+49 89 92103 559 (German)  
+33 1 69 35 48 48 (French)  
[support@freescale.com](mailto:support@freescale.com)

### **Japan:**

Freescale Semiconductor Japan Ltd.  
Headquarters  
ARCO Tower 15F  
1-8-1, Shimo-Meguro, Meguro-ku,  
Tokyo 153-0064  
Japan  
0120 191014 or +81 3 5437 9125  
[support.japan@freescale.com](mailto:support.japan@freescale.com)

### **Asia/Pacific:**

Freescale Semiconductor Hong Kong Ltd.  
Technical Information Center  
2 Dai King Street  
Tai Po Industrial Estate  
Tai Po, N.T., Hong Kong  
+800 2666 8080  
[support.asia@freescale.com](mailto:support.asia@freescale.com)

### **For Literature Requests Only:**

Freescale Semiconductor Literature Distribution Center  
P.O. Box 5405  
Denver, Colorado 80217  
1-800-441-2447 or 303-675-2140  
Fax: 303-675-2150  
[LDCForFreescaleSemiconductor@hibbertgroup.com](mailto:LDCForFreescaleSemiconductor@hibbertgroup.com)

Information in this document is provided solely to enable system and software implementers to use Freescale Semiconductor products. There are no express or implied copyright licenses granted hereunder to design or fabricate any integrated circuits or integrated circuits based on the information in this document.

Freescale Semiconductor reserves the right to make changes without further notice to any products herein. Freescale Semiconductor makes no warranty, representation or guarantee regarding the suitability of its products for any particular purpose, nor does Freescale Semiconductor assume any liability arising out of the application or use of any product or circuit, and specifically disclaims any and all liability, including without limitation consequential or incidental damages. "Typical" parameters that may be provided in Freescale Semiconductor data sheets and/or specifications can and do vary in different applications and actual performance may vary over time. All operating parameters, including "Typicals", must be validated for each customer application by customer's technical experts. Freescale Semiconductor does not convey any license under its patent rights nor the rights of others. Freescale Semiconductor products are not designed, intended, or authorized for use as components in systems intended for surgical implant into the body, or other applications intended to support or sustain life, or for any other application in which the failure of the Freescale Semiconductor product could create a situation where personal injury or death may occur. Should Buyer purchase or use Freescale Semiconductor products for any such unintended or unauthorized application, Buyer shall indemnify and hold Freescale Semiconductor and its officers, employees, subsidiaries, affiliates, and distributors harmless against all claims, costs, damages, and expenses, and reasonable attorney fees arising out of, directly or indirectly, any claim of personal injury or death associated with such unintended or unauthorized use, even if such claim alleges that Freescale Semiconductor was negligent regarding the design or manufacture of the part.

Freescale™ and the Freescale logo are trademarks of Freescale Semiconductor, Inc. All other product or service names are the property of their respective owners.

© Freescale Semiconductor, Inc. 2005. All rights reserved.