

**Features**

- Step-Up type Charge Pump
- Input Range 2.7V to 5V
- Low input current 25 $\mu$ A
- High Output Voltage Accuracy  $\pm 4\%$
- 100mA output current with  $V_{IN} \geq 3.0V$
- 50mA output current with  $V_{IN} \geq 2.7V$
- High Frequency 750KHz operation
- SOT-26 Package

**Applications**

- Cellular Phones
- LED Backlight Driver
- DSC Flash Unit for IGBT trigger Level

**General Description**

The AT1310 is a MicroPower switched-capacitor voltage converter that delivers a regulated output. No external inductor is required for operation. Using three small capacitors, the AT1310 can deliver up to 100mA to the regulated output. The AT1310 features very low quiescent current and high frequency over a large portion of its load range making this device ideal for battery-powered applications.

**Block Diagram**

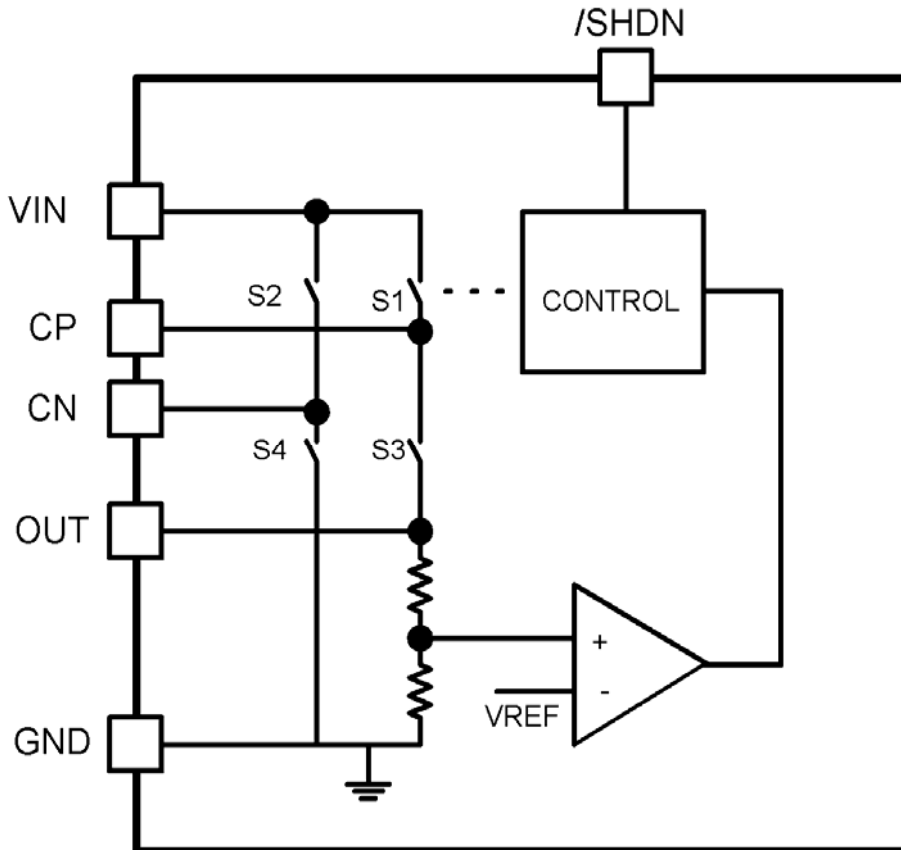

Aimtron reserves the right without notice to change this circuitry and specifications.

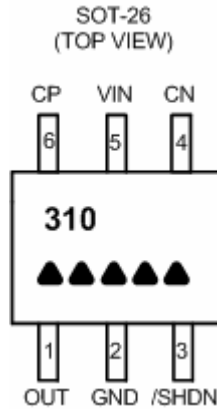
**Pin Configuration(or Pin Assignment)**

**Ordering Information**

Part number	Package	Marking
AT1310X	SOT-26	▲▲▲▲▲ Date Code
AT1310X_PBF	SOT-26, PBF	▲▲▲▲▲ ,Date Code with one bottom line

▲▲▲▲▲ : Date Code

*\*For more marking information, contact out sales representative directly*

**Pin Description**

Pin No.	Symbol	I/O	Description
1	OUT	O	Regulated Output
2	GND	P	Ground
3	/SHDN	I	Chip Enable Input
4	CN	-	Flying Capacitor negative terminal
5	VIN	P	Input Supply
6	CP	+	Flying Capacitor positive terminal

**Absolute Maximum Ratings\*1**

 (T<sub>a</sub>=+25°C)

Parameter	Symbol	Condition	Rated Value		Unit
			Min.	Max.	
Power supply voltage	V <sub>IN</sub>	—	—	6.0	V
OUT pin voltage	V <sub>OUT</sub>	—	—	6.0	V
SHDN pin voltage	V <sub>SHDN</sub>	—	—	6.0	V
Allowable dissipation	P <sub>D</sub>	—	—	150	mW
Operating temperature	T <sub>OP</sub>	—	-30	+85	°C
Storage temperature	T <sub>stg</sub>	—	-55	+125	°C

1. Stresses beyond those listed under “Absolute Maximum Ratings” may cause permanent damage to the device. These are stress ratings only, and functional operation of the device at these or any other conditions beyond those indicated in the operational sections of the specifications is not implied. Exposure to absolute maximum rating conditions for extended periods may affect device reliability.

**Electrical Characteristics**

 (T<sub>a</sub>=+25°C)

Parameter	Symbol	Condition	Values			Unit
			Min.	Typ.	Max.	
Input Voltage	V <sub>IN</sub>	V <sub>OUT</sub> =5.0V	2.7	-	V <sub>OUT</sub>	V
No Load Supply Current	V <sub>Start</sub>	2.7V < V <sub>IN</sub> < 5.0V, I <sub>OUT</sub> =0mA, /SHDN=V <sub>IN</sub>	-	25	40	μA
Output Voltage	V <sub>OUT</sub>	2.7V < V <sub>IN</sub> < 5.0V, I <sub>OUT</sub> ≤50mA	4.8	5.0	5.2	V
		3.0V < V <sub>IN</sub> < 5.0V, I <sub>OUT</sub> ≤100mA	4.8	5.0	5.2	V
Shutdown Current	I <sub>SHDN</sub>	2.7V < V <sub>IN</sub> < 3.6V, I <sub>OUT</sub> =0mA, /SHDN=0V	-	-	1	μA
		3.6V < V <sub>IN</sub> < 5.0V, I <sub>OUT</sub> =0mA, /SHDN=0V	-	-	4	μA
Ripple Current	V <sub>Ripple</sub>	V <sub>IN</sub> =3V, I <sub>OUT</sub> =50mA	-	25	-	mV
		V <sub>IN</sub> =3V, I <sub>OUT</sub> =100mA	-	30	-	mV
Efficiency	η	V <sub>IN</sub> =3V, I <sub>OUT</sub> =50mA	-	83	-	%
		V <sub>IN</sub> =2.7V, I <sub>OUT</sub> =50mA	-	92	-	%
Frequency	F	Oscillator Free Running	-	750	-	KHz
/SHDN Input Threshold	V <sub>IH</sub>		1.4	-	-	V
	V <sub>IL</sub>		-	-	0.3	V
/SHDN Input Current	I <sub>IH</sub>	/SHDN= V <sub>IN</sub>	-2	-	2	μA
	I <sub>IL</sub>	/SHDN= 0V	-2	-	2	μA
OUT Turn-ON time	t <sub>ON</sub>	V <sub>IN</sub> =3V, I <sub>OUT</sub> =0mA	-	2	-	ms
Short-Circuit Current	I <sub>SC</sub>	V <sub>IN</sub> =3V, V <sub>OUT</sub> =GND, /SHDN=3V	-	300	-	mA

Typical characteristics :

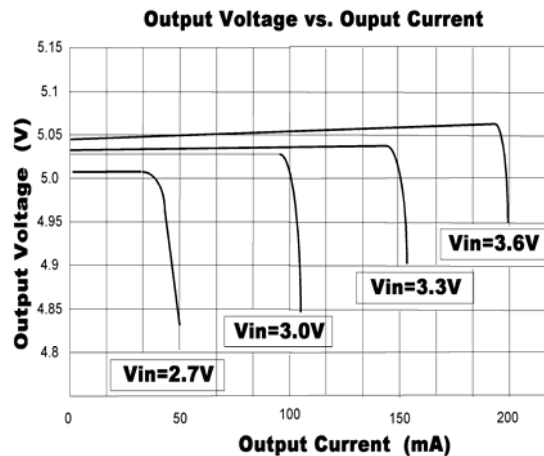
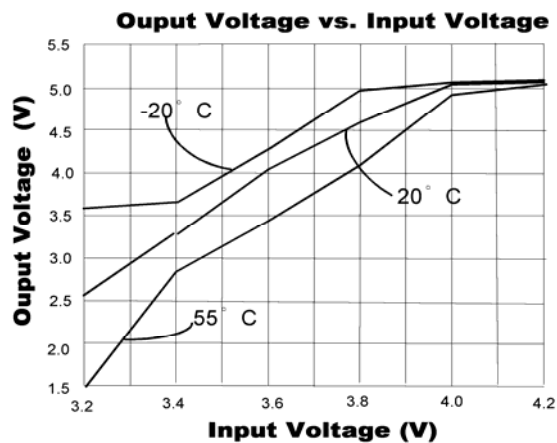
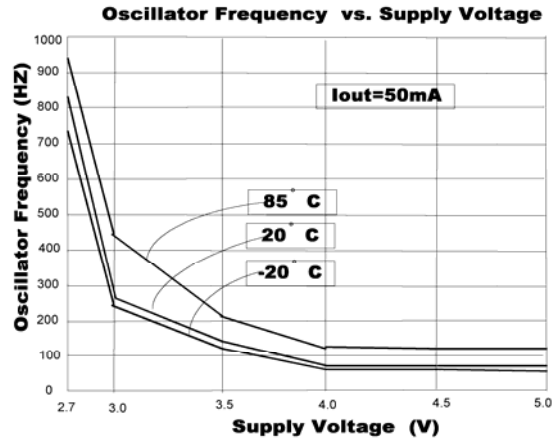
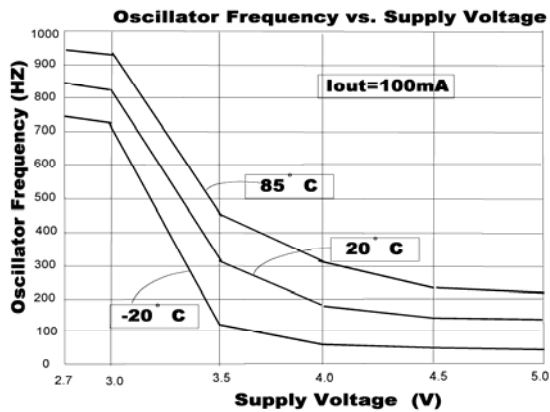
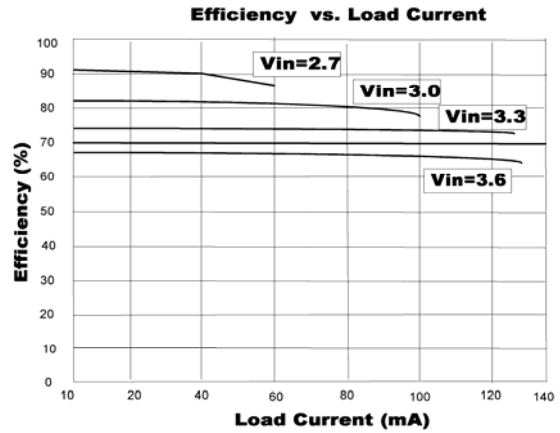
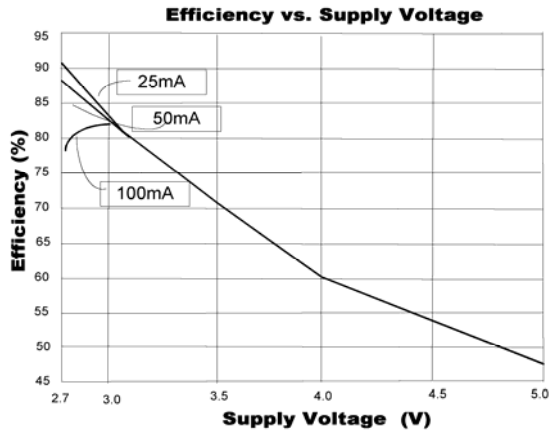

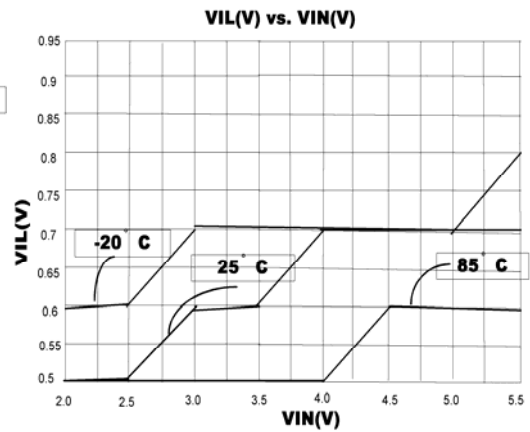
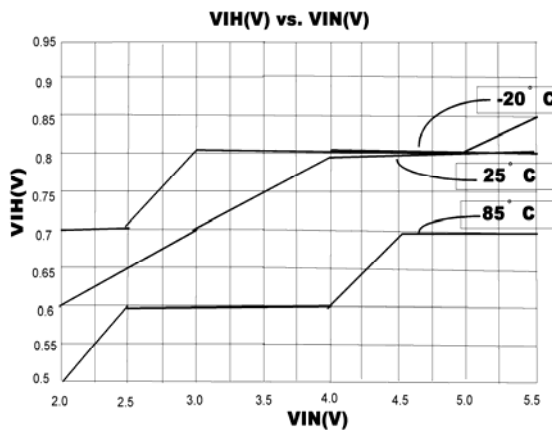
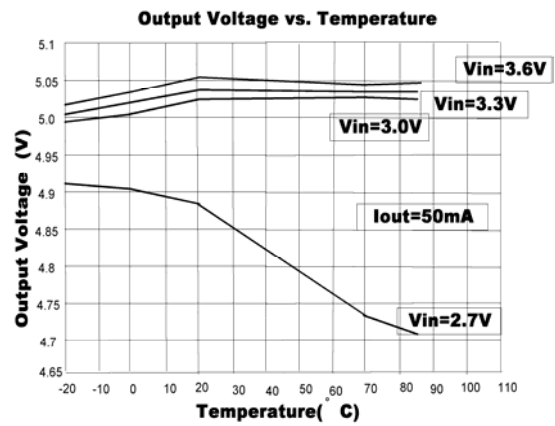
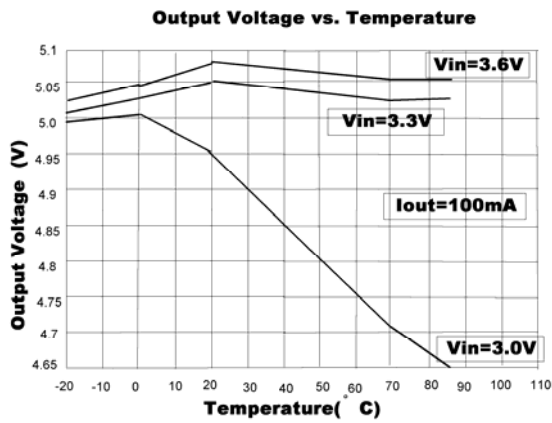

**Typical Application Schematic**

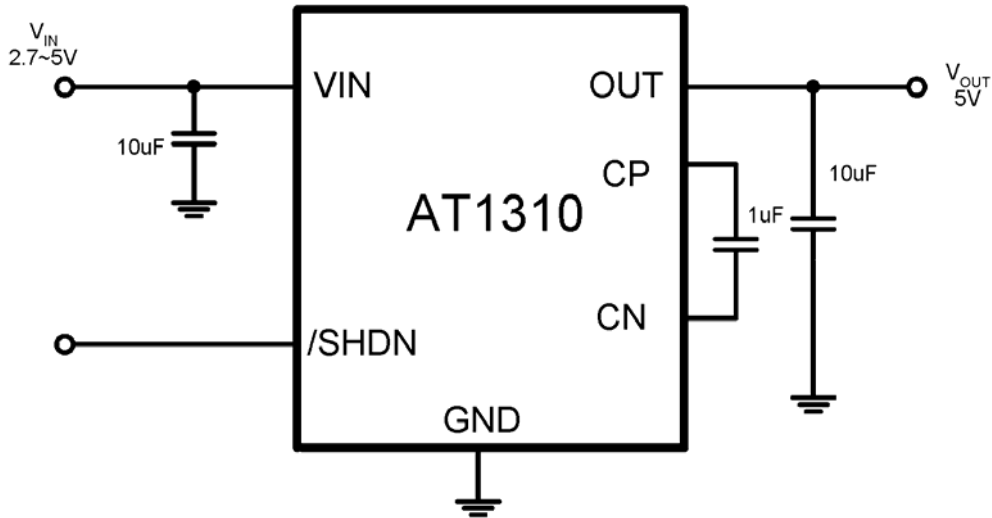

*Fig1. Typical Charge Pump Boost Converter Circuit*

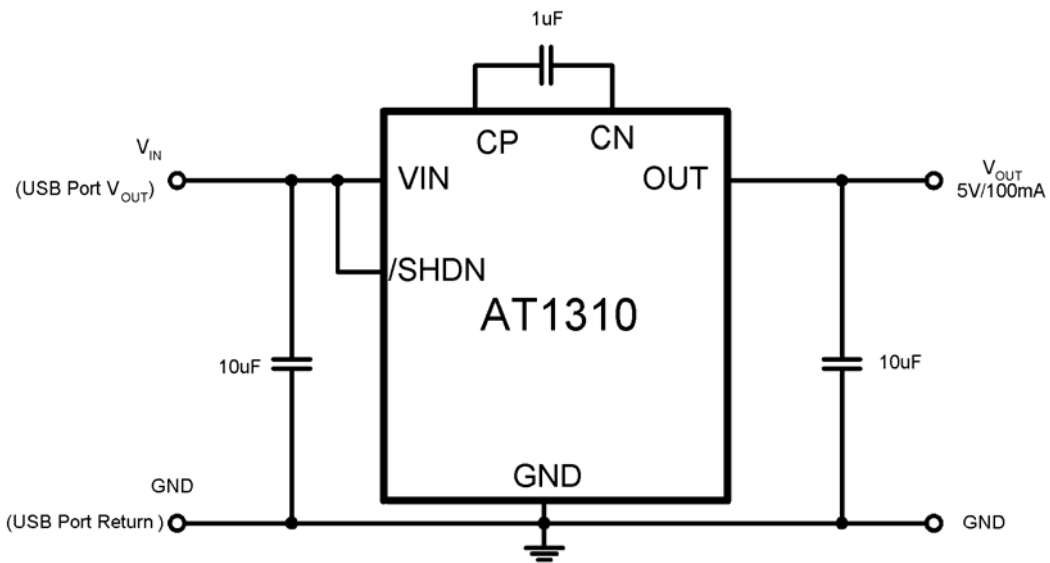

*Fig2. 5V/100mA supply powered from a USB Port*

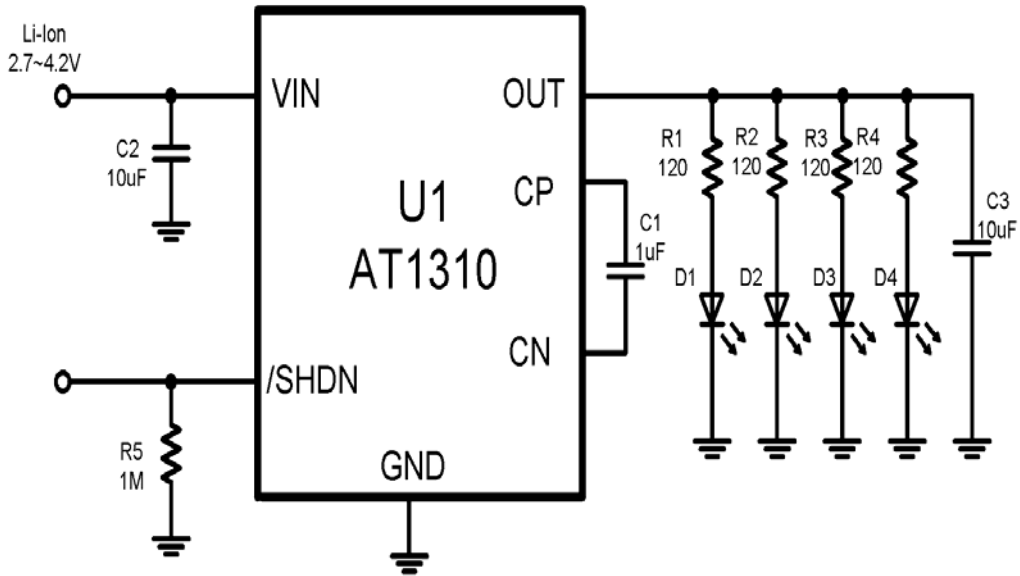

*Fig3. LED Driver from a Li-Ion Battery Source*

## Application Information

### 1. Capacitor Selection

It is very important to select the capacitors  $C_{IN}$ ,  $C_{OUT}$  and  $C_{FLY}$  because they will affect turn on time, output ripple and transient performance. Ceramic capacitors offer many advantages over other tantalum and aluminum electrolytic counterparts. In general, the capacitors can be used 10 $\mu$ F for  $C_{IN}$  and  $C_{OUT}$ , and 1 $\mu$ F for  $C_{FLY}$  under maximum output load conditions. Lower values for  $C_{IN}$ ,  $C_{OUT}$  and  $C_{FLY}$  may be utilized for light load current applications. Large ceramic capacitors are typically composed of X7R, X5R, Z5U or Y5V dielectric materials. If Y5V and Z5U are selected for used with the charge pump, the nominal value should be doubled to compensated for the capacitor tolerance which can vary more than  $\pm 50\%$  over operating temperature range. X7R and X5R dielectrics are much more desirable. The temperature tolerance of X7R dielectric is better than  $\pm 15\%$ .

### 2. Charge Pump Efficiency

The AT1310 is a regulated output voltage charger pump converter. The Efficiency can be defined as a linear voltage regulator with an effective output voltage that is equal to two times the input voltage. The expression to define the ideal efficiency can be shown as:

$$\eta = \frac{P_{OUT}}{P_{IN}} = \frac{V_{OUT} \times I_{OUT}}{V_{IN} \times 2I_{OUT}} = \frac{V_{OUT}}{2 \times V_{IN}}$$

Refer to the Typical Characteristics section for measured plots of efficiency versus input voltage and output load current for the given charge pump output voltage options.

### 3. Layout Guideline

As a general rule for charge pump boost converters, all external capacitors should be located as closed as possible to the device package with minimum length trace connections. A local component side ground plane is recommended. If this is not possible due to the layout limitations, assure good ground connections by the use of large or multiple PCB via's.

Refer to the following AT1310 evaluation board layout. ( Application Circuit Fig3.)



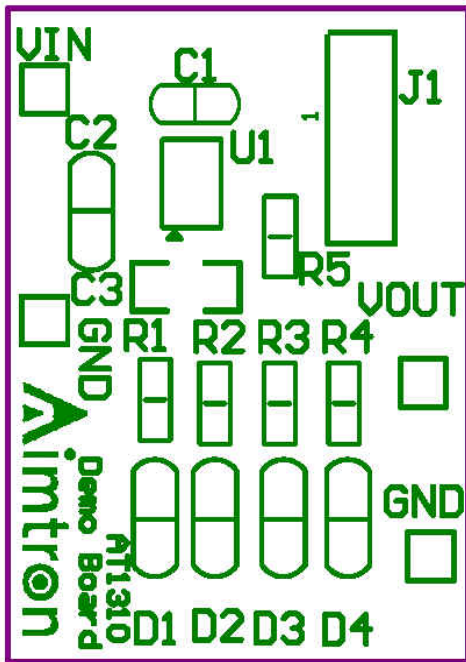

TopOverLayer

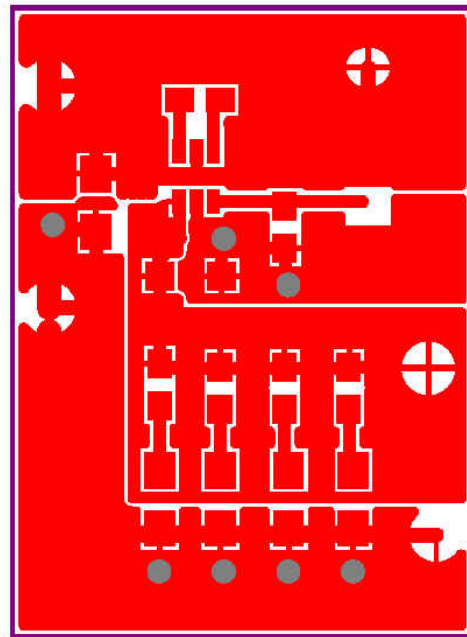

BottomLayer

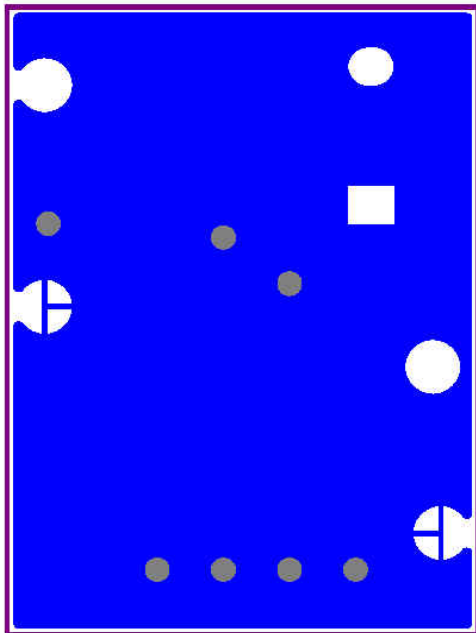

TopLayer

Small Outline SOT-26

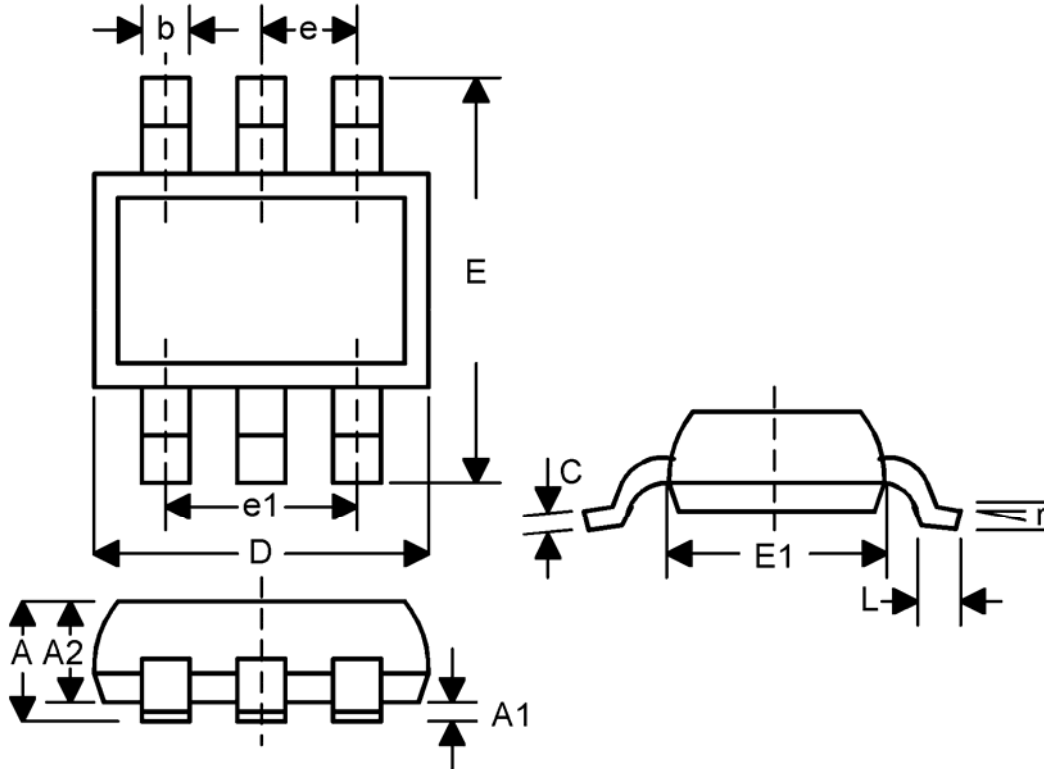

SYMBOL	INCHES		MILLIMETERS		NOTES
	MIN	MAX	MIN	MAX	
A	0.035	0.057	0.90	1.45	-
A1	0.000	0.006	0.00	0.15	-
A2	0.035	0.051	0.90	1.30	-
b	0.010	0.020	0.25	0.50	-
C	0.003	0.008	0.08	0.20	-
D	0.110	0.122	2.80	3.10	-
E	0.102	0.118	2.60	3.00	-
E1	0.059	0.069	1.50	1.75	-
L	0.014	0.022	0.35	0.55	-
e	0.037ref		0.95ref		-
e1	0.075ref		1.90ref		-
r	0 <sup>0</sup>	10 <sup>0</sup>	0 <sup>0</sup>	10 <sup>0</sup>	-

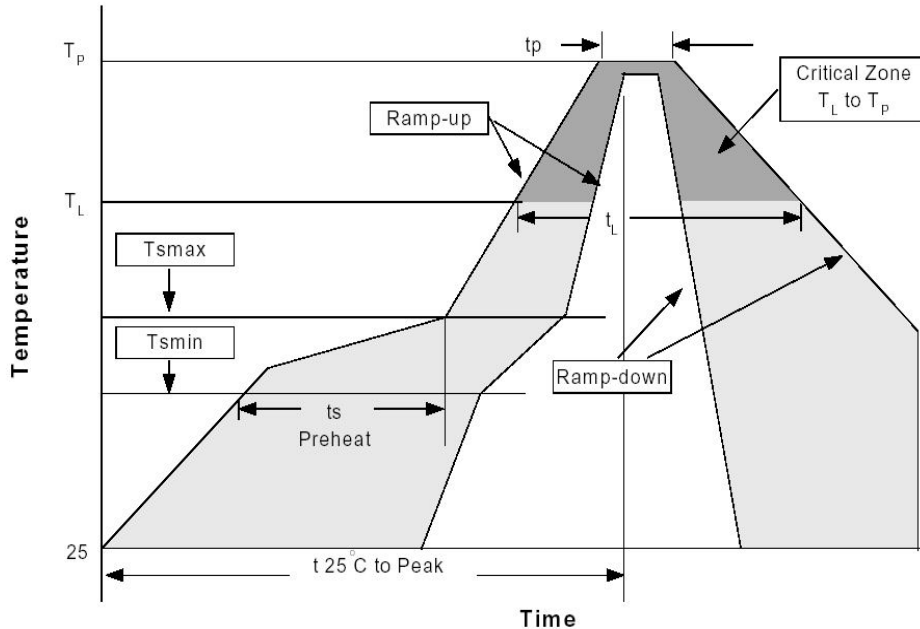
**Reflow Profiles**

Profile Feature	Sn-Pb Eutectic Assembly		Pb-Free Assembly	
	Large Body Pkg. thickness ≥2.5mm or Pkg. volume ≥350mm <sup>3</sup>	Small Body Pkg. thickness <2.5mm or Pkg. volume <350mm <sup>3</sup>	Large Body Pkg. thickness ≥2.5mm or Pkg. volume ≥350mm <sup>3</sup>	Small Body Pkg. thickness ≥2.5mm or Pkg. volume ≥350mm <sup>3</sup>
Average ramp-up rate (T <sub>L</sub> to T <sub>P</sub> )	3°C/second max.		3°C/second max.	
Preheat -Temperature Min(T <sub>smin</sub> ) -Temperature Max (T <sub>smax</sub> ) -Time (min to max)(t <sub>s</sub> )	100°C 150°C 60-120 seconds		150°C 200°C 60-180 seconds	
T <sub>smax</sub> to T <sub>L</sub> -Ramp-up Rate			3°C/second max.	
Time maintained above: -Temperature (T <sub>L</sub> ) -Time (t <sub>L</sub> )	183°C 60-150 seconds		217°C 60-150 seconds	
Peak Temperature(T <sub>P</sub> )	225+0/-5°C	240+0/-5°C	245+0/-5°C	250+0/-5°C
Time within 5°C of actual Peak Temperature (t <sub>p</sub> )	10-30 seconds	10-30 seconds	10-30 seconds	20-40 seconds
Ramp-down Rate	6°C/second max.		3°C/second max.	
Time 25°C to Peak Temperature	6 minutes max.		8 minutes max.	

\*All temperatures refer to topside of the package, measured on the package body surface.