

FEATURES

Analog/DVI dual interface

Supports high bandwidth digital content protection

RGB-to-YCbCr 2-way color conversion

Automated clamping level adjustment

1.8 V/3.3 V power supply

100-lead, Pb-free LQFP

RGB and YCbCr output formats

Analog interface

8-bit triple ADC

150 MSPS maximum conversion rate

Macrovision® detection

2:1 input mux

Full sync processing

Sync detect for hot plugging

Midscale clamping

Digital video interface

DVI 1.0

150 MHz DVI receiver

Supports HDCP 1.1

APPLICATIONS

Advanced TVs

HDTVs

Projectors

LCD monitors

GENERAL DESCRIPTION

The AD9396 offers designers the flexibility of an analog interface and digital visual interface (DVI) receiver integrated on a single chip. Also included is support for high bandwidth digital content protection (HDCP).

The AD9396 is a complete 8-bit, 150 MSPS monolithic analog interface optimized for capturing component video (YPbPr) and RGB graphics signals. Its 150 MSPS encode rate capability and full power analog bandwidth of 330 MHz supports all HDTV formats (up to 1080p and 720p) and FPD resolutions up to SXGA (1280 × 1024 @ 80 Hz).

The analog interface includes a 150 MHz triple ADC with internal 1.25 V reference, a phase-locked loop (PLL), programmable gain, offset, and clamp control. The user provides only 1.8 V and 3.3 V power supply, analog input, and HSYNC. Three-state CMOS outputs may be powered from 1.8 V to 3.3V. The on-chip PLL generates a pixel clock from HSYNC. Pixel

Rev. 0

Information furnished by Analog Devices is believed to be accurate and reliable. However, no responsibility is assumed by Analog Devices for its use, nor for any infringements of patents or other rights of third parties that may result from its use. Specifications subject to change without notice. No license is granted by implication or otherwise under any patent or patent rights of Analog Devices. Trademarks and registered trademarks are the property of their respective owners.

FUNCTIONAL BLOCK DIAGRAM

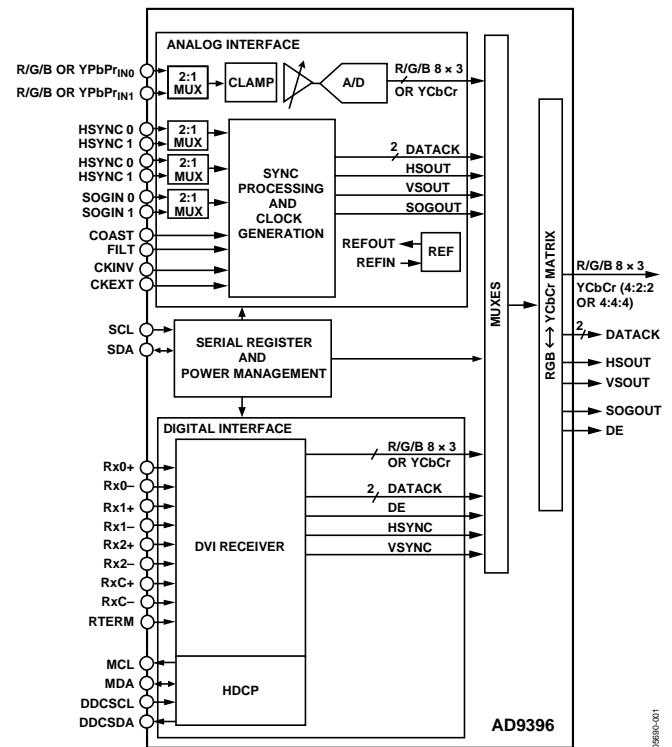

Figure 1.

clock output frequencies range from 12 MHz to 150 MHz. PLL clock jitter is typically less than 700 ps p-p at 150 MHz. The AD9396 also offers full sync processing for composite sync and sync-on-green (SOG) applications.

The AD9396 contains a DVI-compatible receiver and supports all HDTV formats (up to 1080p and 720p) and display resolutions up to SXGA (1280 × 1024 @ 80 Hz). The receiver features an intrapair skew tolerance of up to one full clock cycle. With the inclusion of HDCP, displays may now receive encrypted video content. The AD9396 allows for authentication of a video receiver, decryption of encoded data at the receiver, and renewability of that authentication during transmission as specified by the HDCP 1.1 protocol.

Fabricated in an advanced CMOS process, the AD9396 is provided in a space-saving, 100-lead, surface-mount, Pb-free plastic LQFP and is specified over the 0°C to 70°C temperature range.

TABLE OF CONTENTS

Features	1	2-Wire Serial Register Map	21
Applications.....	1	2-Wire Serial Control Register Details	29
Functional Block Diagram	1	Chip Identification	29
General Description.....	1	PLL Divider Control	29
Specifications.....	3	Clock Generator Control	29
Analog Interface Electrical Characteristics.....	3	Input Gain	30
Digital Interface Electrical Characteristics	4	Input Offset	30
Absolute Maximum Ratings.....	6	Sync	30
Explanation of Test Levels	6	Coast and Clamp Controls.....	31
ESD Caution.....	6	Status of Detected Signals	31
Pin Configuration and Function Descriptions.....	7	Polarity Status	32
Design Guide.....	11	BT656 Generation	36
General Description	11	Macrovision.....	36
Digital Inputs	11	Color Space Conversion	37
Analog Input Signal Handling.....	11	2-Wire Serial Control Port	39
HSYNC and VSYNC Inputs.....	11	PCB Layout Recommendations.....	41
Serial Control Port	11	Analog Interface Inputs	41
Output Signal Handling.....	11	Power Supply Bypassing.....	41
Clamping	11	PLL	41
Timing.....	15	Outputs (Both Data and Clocks).....	42
DVI Receiver	19	Digital Inputs	42
DE Generator	19	Color Space Converter (CSC) Common Settings.....	43
4:4:4 to 4:2:2 Filter	19	Outline Dimensions	45
Timing Diagrams.....	20	Ordering Guide	45

REVISION HISTORY

10/05—Revision 0: Initial Version

SPECIFICATIONS

ANALOG INTERFACE ELECTRICAL CHARACTERISTICS

$V_{DD}, V_D = 3.3\text{ V}$, $DV_{DD} = PV_{DD} = 1.8\text{ V}$, ADC clock = maximum.

Table 1.

Parameter	Temp	Test Level	AD9396KSTZ-100			AD9396KSTZ-150			Unit
			Min	Typ	Max	Min	Typ	Max	
RESOLUTION				8			8		Bits
DC ACCURACY									
Differential Nonlinearity	25°C	I		-0.6	+1.6/-1.0		±0.7	+1.8/-1.0	LSB
Integral Nonlinearity	25°C	I		±1.0	±2.1		±1.1	±2.25	LSB
No Missing Codes	Full			Guaranteed			Guaranteed		
ANALOG INPUT									
Input Voltage Range									
Minimum	Full	VI			0.5			0.5	V p-p
Maximum	Full	VI	1.0			1.0			V p-p
Gain Tempco	25°C	V		100			220		ppm/°C
Input Bias Current	25°C	V		0.2			1		µA
Input Full-Scale Matching	25°C	VI		1.25	5		1.25	5	%FS
	Full	VI		1.50	7		1.50	7	%FS
Offset Adjustment Range	Full	V		50			50		%FS
SWITCHING PERFORMANCE ¹									
Maximum Conversion Rate	Full	VI	100			150			MSPS
Minimum Conversion Rate	Full	VI			10		10		MSPS
Data to Clock Skew	Full	IV	-0.5		+2.0	-0.5		+2.0	ns
SERIAL PORT TIMING									
t _{BUFF}	Full	VI	4.7			4.7			µs
t _{STAH}	Full	VI	4.0			4.0			µs
t _{DHO}	Full	VI	0			0			µs
t _{DAL}	Full	VI	4.7			4.7			µs
t _{DAH}	Full	VI	4.0			4.0			µs
t _{DSU}	Full	VI	250			250			ns
t _{STASU}	Full	VI	4.7			4.7			µs
t _{STOSU}	Full	VI	4.0			4.0			µs
HSYNC Input Frequency	Full	VI	15		110	15		110	KHz
Maximum PLL Clock Rate	Full	VI	100			150			MHz
Minimum PLL Clock Rate	Full	IV			12			12	MHz
PLL Jitter	25°C	IV		700			700		ps p-p
Sampling Phase Tempco	Full	IV		15			15		ps/°C
DIGITAL INPUTS (5 V Tolerant)									
Input Voltage, High (V _{IH})	Full	VI	2.6			2.6			V
Input Voltage, Low (V _{IL})	Full	VI			0.8			0.8	V
Input Current, High (I _{IH})	Full	V		-82			-82		µA
Input Current, Low (I _{IL})	Full	V		82			82		µA
Input Capacitance	25°C	V		3			3		pF
DIGITAL OUTPUTS									
Output Voltage, High (V _{OH})	Full	VI	V _{DD} - 0.1			V _{DD} - 0.1			V
Output Voltage, Low (V _{OL})	Full	VI			0.4			0.4	V
Duty Cycle, DATAACK	Full	V	45	50	55	45	50	55	%
Output Coding				Binary			Binary		

AD9396

Parameter	Temp	Test Level	AD9396KSTZ-100			AD9396KSTZ-150			Unit
			Min	Typ	Max	Min	Typ	Max	
POWER SUPPLY									
V _D Supply Voltage	Full	IV	3.15	3.3	3.47	3.15	3.3	3.47	V
DV _{DD} Supply Voltage	Full	IV	1.7	1.8	1.9	1.7	1.8	1.9	V
V _{DD} Supply Voltage	Full	IV	1.7	3.3	3.47	1.7	3.3	3.47	V
PV _{DD} Supply Voltage	Full	IV	1.7	1.8	1.9	1.7	1.8	1.9	V
I _D Supply Current (V _D)	25°C	VI		260	300			330	mA
I _{DVDD} Supply Current (DV _{DD})	25°C	VI		45	60			85	mA
I _{DD} Supply Current (V _{DD}) ²	25°C	VI		37	100 ³			130 ³	mA
IP _{VDD} Supply Current (PV _{DD})	25°C	VI		10	15			20	mA
Total Power	Full	VI		1.1	1.4		1.15	1.4	W
Power-Down Dissipation	Full	VI		130			130		mW
DYNAMIC PERFORMANCE									
Analog Bandwidth, Full Power	25°C	V		330			330		MHz
Signal-to-Noise Ratio (SNR) Without Harmonics	25°C	I		46			46		dB
f _{IN} = 40.7 MHz	Full	V		45			45		dB
Crosstalk	Full	V		60			60		dBc
THERMAL CHARACTERISTICS									
θ _{JA} Junction-to-Ambient		V		35			35		°C/W

¹ Drive strength = high.

² DATAACK load = 15 pF, data load = 5 pF.

³ Specified current and power values with a worst-case pattern (on/off).

DIGITAL INTERFACE ELECTRICAL CHARACTERISTICS

V_{DD} = V_D = 3.3 V, DV_{DD} = PV_{DD} = 1.8 V, ADC clock = maximum.

Table 2.

Parameter	Test Level	Conditions	AD9396KSTZ-100			AD9396KSTZ-150			Unit
			Min	Typ	Max	Min	Typ	Max	
RESOLUTION				8			8		Bit
DC DIGITAL I/O Specifications									
High Level Input Voltage, (V _{IH})	VI		2.5			2.5		0.8	V
Low Level Input Voltage, (V _{IL})	VI				0.8			0.8	V
High Level Output Voltage, (V _{OH})	VI		V _{DD} - 0.1						V
Low Level Output Voltage, (V _{OL})	VI		V _{DD} - 0.1		0.1			0.1	V
DC SPECIFICATIONS									
Output High Level (I _{OH}) (V _{OUT} = V _{OH})	IV	Output drive = high		36			36		mA
	IV	Output drive = low		24			24		mA
Output Low Level (I _{OL}) (V _{OUT} = V _{OL})	IV	Output drive = high		12			12		mA
	IV	Output drive = low		8			8		mA
DATAACK High Level V _{OH} , (V _{OUT} = V _{OH})	IV	Output drive = high		40			40		mA
	IV	Output drive = low		20			20		mA
DATAACK Low Level V _{OL} , (V _{OUT} = V _{OL})	IV	Output drive = high		30			30		mA
	IV	Output drive = low		15			15		mA
Differential Input Voltage, Single-Ended Amplitude	IV		75		700	75		700	mV

Parameter	Test Level	Conditions	AD9396KSTZ-100			AD9396KSTZ-150			Unit
			Min	Typ	Max	Min	Typ	Max	
POWER SUPPLY									
V _D Supply Voltage	IV		3.15	3.3	3.47	3.15	3.3	3.47	V
V _{DD} Supply Voltage	IV		1.7	3.3	347	1.7	3.3	347	V
DV _{DD} Supply Voltage	IV		1.7	1.8	1.9	1.7	1.8	1.9	V
PV _{DD} Supply Voltage	IV		1.7	1.8	1.9	1.7	1.8	1.9	V
I _{VD} Supply Current (Typical Pattern) ¹	V			80	100		80	110	mA
I _{VDD} Supply Current (Typical Pattern) ²	V			40	100 ³		55	175 ³	mA
I _{DVDD} Supply Current (Typical Pattern) ^{1, 4}	V			88	110		110	145	mA
I _{PVDD} Supply Current (Typical Pattern) ¹	V			26	35		30	40	mA
Power-Down Supply Current (I _{PD})	VI			130			130		mA
AC SPECIFICATIONS									
Intrapair (+ to -) Differential Input Skew (T _{DPS})	IV						360		ps
Channel-to-Channel Differential Input Skew (T _{CCS})	IV						6		Clock Period
Low-to-High Transition Time for Data and Controls (D _{LHT})	IV	Output drive = high; C _L = 10 pF					900		ps
	IV	Output drive = low; C _L = 5 pF					1300		ps
Low-to-High Transition Time for DATAACK (D _{LHT})	IV	Output drive = high; C _L = 10 pF					650		ps
	IV	Output drive = low; C _L = 5 pF					1200		ps
High-to-Low Transition Time for Data and Controls (D _{HLT})	IV	Output drive = high; C _L = 10 pF					850		ps
	IV	Output drive = low; C _L = 5 pF					1250		ps
High-to-Low Transition Time for DATAACK (D _{HLT})	IV	Output drive = high; C _L = 10 pF					800		ps
	IV	Output drive = low; C _L = 5 pF					1200		ps
Clock to Data Skew ⁵ (T _{SKEW})	IV		-0.5		+2.0	-0.5	2.0		ns
Duty Cycle, DATAACK ⁵	IV		45	50			55		%
DATAACK Frequency (F _{CIP})	VI		20				150		MHz

¹ The typical pattern contains a gray scale area, output drive = high. Worst-case pattern is alternating black and white pixels.

² The typical pattern contains a gray scale area, output drive = high.

³ Specified current and power values with a worst-case pattern (on/off).

⁴ DATAACK load = 10 pF, data load = 5 pF.

⁵ Drive strength = high.

ABSOLUTE MAXIMUM RATINGS

Table 3.

Parameter	Rating
V _D	3.6 V
V _{DD}	3.6 V
DV _{DD}	1.98 V
PV _{DD}	1.98 V
Analog Inputs	V _D to 0.0 V
Digital Inputs	5 V to 0.0 V
Digital Output Current	20 mA
Operating Temperature Range	-25°C to +85°C
Storage Temperature Range	-65°C to +150°C
Maximum Junction Temperature	150°C
Maximum Case Temperature	150°C

Stresses above those listed under Absolute Maximum Ratings may cause permanent damage to the device. This is a stress rating only; functional operation of the device at these or any other conditions above those indicated in the operational section of this specification is not implied. Exposure to absolute maximum rating conditions for extended periods may affect device reliability.

EXPLANATION OF TEST LEVELS

Table 4.

Level	Test
I	100% production tested.
II	100% production tested at 25°C and sample tested at specified temperatures.
III	Sample tested only.
IV	Parameter is guaranteed by design and characterization testing.
V	Parameter is a typical value only.
VI	100% production tested at 25°C; guaranteed by design and characterization testing.

ESD CAUTION

ESD (electrostatic discharge) sensitive device. Electrostatic charges as high as 4000 V readily accumulate on the human body and test equipment and can discharge without detection. Although this product features proprietary ESD protection circuitry, permanent damage may occur on devices subjected to high energy electrostatic discharges. Therefore, proper ESD precautions are recommended to avoid performance degradation or loss of functionality.



PIN CONFIGURATION AND FUNCTION DESCRIPTIONS

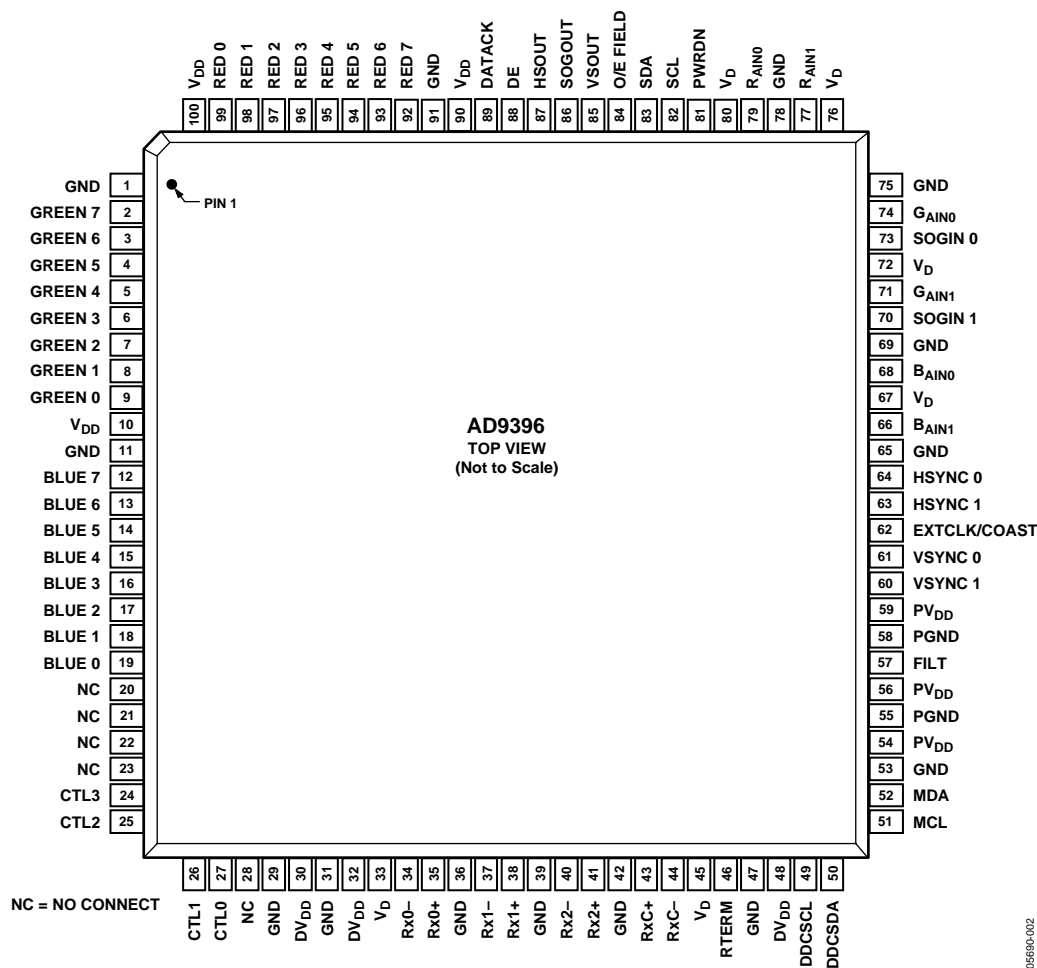

Figure 2. Pin Configuration

065690-002

Table 5. Complete Pinout List

Pin Type	Pin No.	Mnemonic	Function	Value
INPUTS	79	RAIN0	Analog Input for Converter R Channel 0	0.0 V to 1.0 V
	77	RAIN1	Analog Input for Converter R Channel 1	0.0 V to 1.0 V
	74	GAIN0	Analog Input for Converter G Channel 0	0.0 V to 1.0 V
	71	GAIN1	Analog Input for Converter G Channel 1	0.0 V to 1.0 V
	68	BAIN0	Analog Input for Converter B Channel 0	0.0 V to 1.0 V
	66	BAIN1	Analog Input for Converter B Channel 1	0.0 V to 1.0 V
	64	HSYNC 0	Horizontal SYNC Input for Channel 0	3.3 V CMOS
	63	HSYNC 1	Horizontal SYNC Input for Channel 1	3.3 V CMOS
	61	VSYNC 0	Vertical SYNC Input for Channel 0	3.3 V CMOS
	60	VSYNC 1	Vertical SYNC Input for Channel 1	3.3 V CMOS
	73	SOGIN 0	Input for Sync-on-Green Channel 0	0.0 V to 1.0 V
	70	SOGIN 1	Input for Sync-on-Green Channel 1	0.0 V to 1.0 V
	62	EXTCLK	External Clock Input—Shares Pin with COAST	3.3 V CMOS
	62	COAST	PLL COAST Signal Input—Shares Pin with EXTCLK	3.3 V CMOS
81	PWRDN	Power-Down Control	3.3 V CMOS	
OUTPUTS	92 to 99	RED [7:0]	Outputs of Red Converter, Bit 7 is MSB	V _{DD}
	2 to 9	GREEN [7:0]	Outputs of Green Converter, Bit 7 is MSB	V _{DD}
	12 to 19	BLUE [7:0]	Outputs of Blue Converter, Bit 7 is MSB	V _{DD}

AD9396

Pin Type	Pin No.	Mnemonic	Function	Value
OUTPUTS	89	DATAACK	Data Output Clock	V _{DD}
	87	HSOUT	HSYNC Output Clock (Phase-Aligned with DATAACK)	V _{DD}
	85	VSOUT	VSYNC Output Clock (Phase-Aligned with DATAACK)	V _{DD}
	86	SOGOUT	SOG Slicer Output	V _{DD}
	84	O/E FIELD	Odd/Even Field Output	V _{DD}
	24, 25, 26, 27	CTL(3-0)	Control 3, 2, 1, and 0.	V _{DD}
REFERENCES	57	FILT	Connection for External Filter Components for PLL	
POWER SUPPLY	80, 76, 72, 67, 45, 33	V _D	Analog Power Supply and DVI Terminators	3.3 V
	100, 90, 10	V _{DD}	Output Power Supply	1.8 V to 3.3 V
	59, 56, 54	PV _{DD}	PLL Power Supply	1.8 V
	48, 32, 30	DV _{DD}	Digital Logic Power Supply	1.8 V
		GND	Ground	0 V
CONTROL	83	SDA	Serial Port Data I/O	3.3 V CMOS
	82	SCL	Serial Port Data Clock	3.3 V CMOS
HDCP	49	DDCSCL	HDCP Slave Serial Port Data Clock	3.3 V CMOS
	50	DDCSDA	HDCP Slave Serial Port Data I/O	3.3 V CMOS
	51	MCL	HDCP Master Serial Port Data Clock	3.3 V CMOS
	52	MDA	HDCP Master Serial Port Data I/O	3.3 V CMOS
DIGITAL VIDEO DATA	35	Rx0+	Digital Input Channel 0 True	TMDS
	34	Rx0-	Digital Input Channel 0 Complement	TMDS
	38	Rx1+	Digital Input Channel 1 True	TMDS
	37	Rx1-	Digital Input Channel 1 Complement	TMDS
	41	Rx2+	Digital Input Channel 2 True	TMDS
	40	Rx2-	Digital Input Channel 2 Complement	TMDS
DIGITAL VIDEO CLOCK INPUTS	43	RxC+	Digital Data Clock True	TMDS
	44	RxC-	Digital Data Clock Complement	TMDS
DATA ENABLE	88	DE	Data Enable	3.3 V CMOS
RTERM	46	RTERM	Sets Internal Termination Resistance	500 Ω

Table 6. Pin Function Descriptions

Mnemonic	Description
INPUTS	
R _{AIN0}	Analog Input for the Red Channel 0.
G _{AIN0}	Analog Input for the Green Channel 0.
B _{AIN0}	Analog Input for the Blue Channel 0.
R _{AIN1}	Analog Input for the Red Channel 1.
G _{AIN1}	Analog Input for the Green Channel 1.
B _{AIN1}	Analog Input for Blue Channel 1.
	High impedance inputs that accept the red, green, and blue channel graphics signals, respectively. The three channels are identical and can be used for any colors, but colors are assigned for convenient reference. They accommodate input signals ranging from 0.5 V to 1.0 V full scale. Signals should be ac-coupled to these pins to support clamp operation (see Figure 3 for an input reference circuit).
Rx0+	Digital Input Channel 0 True.
Rx0-	Digital Input Channel 0 Complement.
Rx1+	Digital Input Channel 1 True.
Rx1-	Digital Input Channel 1 Complement.
Rx2+	Digital Input Channel 2 True.
Rx2-	Digital input Channel 2 Complement.
	These six pins receive three pairs of transition minimized differential signaling (TMDS) pixel data (at 10x the pixel rate) from a digital graphics transmitter.

Mnemonic	Description
RxC+	Digital Data Clock True.
RxC-	Digital Data Clock Complement. This clock pair receives a TMDS clock at 1× pixel data rate.
HSYNC 0	Horizontal Sync Input Channel 0.
HSYNC 1	Horizontal Sync Input Channel 1. These inputs receive a logic signal that establishes the horizontal timing reference and provides the frequency reference for pixel clock generation. The logic sense of this pin is controlled by Serial Register 0x12, Bits 5:4 (HSYNC polarity). Only the leading edge of HSYNC is active; the trailing edge is ignored. When HSYNC polarity = 0, the falling edge of HSYNC is used. When HSYNC polarity = 1, the rising edge is active. The input includes a Schmitt trigger for noise immunity.
VSYNC 0	Vertical Sync Input Channel 0.
VSYNC 1	Vertical Sync Input Channel 1. These are the inputs for vertical sync.
SOGIN 0	Sync-on-Green Input Channel 0.
SOGIN 1	Sync-on-Green Input Channel 1. These inputs are provided to assist with processing signals with embedded sync, typically on the green channel. The pin is connected to a high speed comparator with an internally generated threshold. The threshold level can be programmed in 10 mV steps to any voltage between 10 mV and 330 mV above the negative peak of the input signal. The default voltage threshold is 150 mV. When connected to an ac-coupled graphics signal with embedded sync, it produces a noninverting digital output on SOGOUT. (This is usually a composite sync signal, containing both vertical and horizontal sync (HSYNC) information that must be separated before passing the horizontal sync signal to HSYNC.) When not used, this input should be left unconnected. For more details on this function and how it should be configured, refer to the HSYNC and VSYNC Inputs section.
EXTCLK/COAST	Coast Input to Clock Generator (Optional). This input may be used to cause the pixel clock generator to stop synchronizing with HSYNC and continue producing a clock at its current frequency and phase. This is useful when processing signals from sources that fail to produce horizontal sync pulses during the vertical interval. The coast signal is generally not required for PC-generated signals. The logic sense of this pin is controlled by coast polarity (Register 0x18, Bits 6:5). When not used, this pin may be grounded and input coast polarity programmed to 1 (Register 0x18, Pin 5), or tied high (to V_D through a 10 k Ω resistor) and input coast polarity programmed to 0. Input coast polarity defaults to 1 at power-up. This pin is shared with the EXTCLK function, which does not affect coast functionality. For more details on coast, see the description in the Clock Generation section.
EXTCLK/COAST	External Clock. This allows the insertion of an external clock source rather than the internally generated PLL-locked clock. This pin is shared with the coast function, does not affect EXTCLK functionality.
RTERM	RTERM is the termination resistor used to drive the AD9396 internally to a precise 50 Ω termination for TMDS lines. This should be a 500 Ω 1% tolerance resistor.
PWRDN	Power-Down Control/Three-State Control. The function of this pin is programmable via Register 0x26 [2:1].
FILT	External Filter Connection. For proper operation, the pixel clock generator PLL requires an external filter. Connect the filter shown in Figure 6 to this pin. For optimal performance, minimize noise and parasitics on this node. For more information see the section on PCB Layout Recommendations.
OUTPUTS	
HSOUT	Horizontal Sync Output. A reconstructed and phase-aligned version of the HSYNC input. Both the polarity and duration of this output can be programmed via the serial bus registers. By maintaining alignment with DATAACK and Data, data timing with respect to horizontal sync can always be determined.
VSOUT	Vertical Sync Output. The separated VSYNC from a composite signal or a direct passthrough of the VSYNC signal. The polarity of this output can be controlled via serial bus bit (Register 0x24 [6]).
SOGOUT	Sync-on-Green Slicer Output. This pin outputs one of four possible signals (controlled by Register 0x24 [2:1]): raw SOG, raw HSYNC, regenerated HSYNC from the filter, or the filtered HSYNC. See Figure 8, the Sync Processing Block Diagram, to view how this pin is connected. (Note: besides slicing off SOG, the output from this pin is not processed on the AD9396. VSYNC separation is performed via the sync separator.
O/E FIELD	Odd/Even Field Bit for Interlaced Video. This output identifies whether the current field (in an interlaced signal) is odd or even. The polarity of this signal is programmable via Register 0x24 [4].

AD9396

Mnemonic	Description
DATA ENABLE CTL(3 to 0)	Data Enable that defines valid video. Can be received in the signal or generated by the AD9396. Control 3, Control 2, Control 1, and Control 0 are output from the DVI stream. Refer to the DVI 1.0 specification for explanation.
SERIAL PORT SDA SCL DDCSDA DDCSCL MDA MCL	Serial Port Data I/O for Programming AD9396 Registers—I ² C® Address is 0x98. Serial Port Data Clock for Programming AD9396 Registers. Serial Port Data I/O for HDCP Communications to Transmitter—I ² C Address is 0x74 or 0x76. Serial Port Data Clock for HDCP Communications to Transmitter. Serial Port Data I/O to EEPROM with HDCP Keys—I ² C Address is 0xA0. Serial Port Data Clock to EEPROM with HDCP Keys.
DATA OUTPUTS Red [7:0] Green [7:0] Blue [7:0]	Data Output, Red Channel. Data Output, Green Channel. Data Output, Blue Channel. The main data outputs. Bit 7 is the MSB. The delay from pixel sampling time to output is fixed, but is different if the color space converter is used. When the sampling time is changed by adjusting the phase register, the output timing is shifted as well. The DATAACK and HSOUT outputs are also moved, so the timing relationship among the signals is maintained.
DATA CLOCK OUTPUT DATAACK	Data Clock Output. This is the main clock output signal used to strobe the output data and HSOUT into external logic. Four possible output clocks can be selected with Register 0x25 [7:6]. These are related to the pixel clock (1/2× pixel clock, 1× pixel clock, 2× frequency pixel clock and a 90° phase shifted pixel clock) and they are produced either by the internal PLL clock generator or EXTCLK and are synchronous with the pixel sampling clock. The polarity of DATAACK can also be inverted via Register 0x24 [0]. The sampling time of the internal pixel clock can be changed by adjusting the phase register. When this is changed, the pixel-related DATAACK timing is shifted as well. The DATA, DATAACK, and HSOUT outputs are all moved, so the timing relationship among the signals is maintained.
POWER SUPPLY ¹ V _D (3.3 V) V _{DD} (1.8 V to 3.3 V) PV _{DD} (1.8 V)	Analog Power Supply. These pins supply power to the ADCs and terminators. They should be as quiet and filtered as possible. Digital Output Power Supply. A large number of output pins (up to 27) switching at high speed (up to 150 MHz) generates many power supply transients (noise). These supply pins are identified separately from the V _D pins, so take care to minimize output noise transferred into the sensitive analog circuitry. If the AD9396 is interfacing with lower voltage logic, V _{DD} may be connected to a lower supply voltage (as low as 1.8 V) for compatibility. Clock Generator Power Supply. The most sensitive portion of the AD9396 is the clock generation circuitry. These pins provide power to the clock PLL and help the user design for optimal performance. The designer should provide quiet, noise-free power to these pins.
DV _{DD} (1.8 V) GND	Digital Input Power Supply. This supplies power to the digital logic. Ground. The ground return for all circuitry on-chip. It is recommended that the AD9396 be assembled on a single solid ground plane, with careful attention to ground current paths.

¹ The supplies should be sequenced such that V_D and V_{DD} are never less than 300 mV below DV_{DD}. At no time should DV_{DD} be more than 300 mV greater than V_D or V_{DD}.

DESIGN GUIDE

GENERAL DESCRIPTION

The AD9396 is a fully integrated solution for capturing analog RGB or YUV signals and digitizing them for display on flat panel monitors, projectors, or PDPs. In addition, the AD9396 has a digital interface for receiving DVI signals and is capable of decoding HDCP-encrypted signals through connections to an external EEPROM. The circuit is ideal for providing an interface for HDTV monitors or as the front end to high performance video scan converters.

Implemented in a high performance CMOS process, the interface can capture signals with pixel rates of up to 150 MHz.

The AD9396 includes all necessary input buffering, signal dc restoration (clamping), offset and gain (brightness and contrast) adjustment, pixel clock generation, sampling phase control, and output data formatting. Included in the output formatting is a color space converter (CSC), which accommodates any input color space and can output any color space. All controls are programmable via a 2-wire serial interface. Full integration of these sensitive analog functions makes system design straightforward and less sensitive to the physical and electrical environment.

DIGITAL INPUTS

All digital control inputs (HSYNC, VSYNC, I²C) on the AD9396 operate to 3.3 V CMOS levels. In addition, all digital inputs except the TMDS (HDMI/DVI) inputs are 5 V tolerant. (Applying 5 V to them does not cause any damage.) TMDS inputs (Rx0+/Rx0-, Rx1+/Rx1-, Rx2+/Rx2-, and RxC+/RxC-) must maintain a 100 Ω differential impedance (through proper PCB layout) from the connector to the input where they are internally terminated (50 Ω to 3.3 V). If additional ESD protection is desired, use of a California Micro Devices (CMD) CM1213 (among others) series low capacitance ESD protection offers 8 kV of protection to the HDMI TMDS lines.

ANALOG INPUT SIGNAL HANDLING

The AD9396 has six high impedance analog input pins for the red, green, and blue channels. They accommodate signals ranging from 0.5 V p-p to 1.0 V p-p.

Signals are typically brought onto the interface board via a DVI-I connector, a 15-pin D connector, or RCA-type connectors. The AD9396 should be located as close as practical to the input connector. Signals should be routed via 75 Ω matched impedance traces to the IC input pins.

At the input pins, the signal should be resistively terminated (75 Ω to the signal ground return) and capacitively coupled to the AD9396 inputs through 47 nF capacitors. These capacitors form part of the dc restoration circuit.

In an ideal world of perfectly matched impedances, the best performance can be obtained with the widest possible signal bandwidth. The ultrawide bandwidth inputs of the AD9396 (330 MHz) can track the input signal continuously as it moves from one pixel level to the next, and digitizes the pixel during a long, flat pixel time. In many systems, however, there are mismatches, reflections, and noise, which can result in excessive ringing and distortion of the input waveform. This makes it more difficult to establish a sampling phase that provides good image quality. It has been shown that a small inductor in series with the input is effective in rolling off the input bandwidth slightly, and providing a high quality signal over a wider range of conditions. Using a Fair-Rite #2508051217Z0 HIGH SPEED SIGNAL CHIP BEAD inductor in the circuit, as shown in Figure 3, gives good results in most applications.

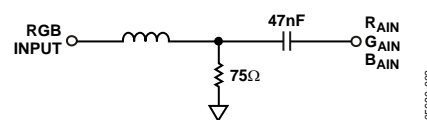

Figure 3. Analog Input Interface Circuit

HSYNC AND VSYNC INPUTS

The interface also takes a horizontal sync signal, which is used to generate the pixel clock and clamp timing. This can be either a sync signal directly from the graphics source, or a preprocessed TTL or CMOS level signal.

The HSYNC input includes a Schmitt trigger buffer for immunity to noise and signals with long rise times. In typical PC-based graphic systems, the sync signals are TTL-level drivers feeding unshielded wires in the monitor cable. As such, no termination is required.

SERIAL CONTROL PORT

The serial control port is designed for 3.3 V logic. However, it is tolerant of 5 V logic signals.

OUTPUT SIGNAL HANDLING

The digital outputs are designed to operate from 1.8 V to 3.3 V (V_{DD}).

CLAMPING

RGB Clamping

To properly digitize the incoming signal, the dc offset of the input must be adjusted to fit the range of the on-board ADC.

Most graphics systems produce RGB signals with black at ground and white at approximately 0.75 V. However, if sync signals are embedded in the graphics, the sync tip is often at ground and black is at 300 mV. Then white is at approximately 1.0 V. Some common RGB line amplifier boxes use emitter-follower buffers to split signals and increase drive capability.

This introduces a 700 mV dc offset to the signal, which must be removed for proper capture by the AD9396.

The key to clamping is to identify a portion (time) of the signal when the graphic system is known to be producing black. An offset is then introduced which results in the ADCs producing a black output (Code 0x00) when the known black input is present. The offset then remains in place when other signal levels are processed, and the entire signal is shifted to eliminate offset errors.

In most PC graphics systems, black is transmitted between active video lines. With CRT displays, when the electron beam has completed writing a horizontal line on the screen (at the right side), the beam is deflected quickly to the left side of the screen (called horizontal retrace) and a black signal is provided to prevent the beam from disturbing the image.

In systems with embedded sync, a blacker-than-black signal (HSYNC) is produced briefly to signal the CRT that it is time to begin a retrace. For obvious reasons, it is important to avoid clamping on the tip of HSYNC. Fortunately, there is virtually always a period following HSYNC, called the back porch, where a good black reference is provided. This is the time when clamping should be done.

Clamp timing employs the AD9396 internal clamp timing generator. The clamp placement register is programmed with the number of pixel periods that should pass after the trailing edge of HSYNC before clamping starts. A second register (clamp duration) sets the duration of the clamp. These are both 8-bit values, providing considerable flexibility in clamp generation. The clamp timing is referenced to the trailing edge of HSYNC because, though HSYNC duration can vary widely, the back porch (black reference) always follows HSYNC. A good starting point for establishing clamping is to set the clamp placement to 0x08 (providing 8 pixel periods for the graphics signal to stabilize after sync) and set the clamp duration to 0x14 (giving the clamp 20 pixel periods to re-establish the black reference). For three-level syncs embedded on the green channel, it is necessary to increase the clamp placement to beyond the positive portion of the sync. For example, a good clamp placement (Register 0x19) for a 720p input is 0x26. This delays the start of clamp by 38 pixel clock cycles after the rising edge of the three-level sync, allowing plenty of time for the signal to return to a black reference.

Clamping is accomplished by placing an appropriate charge on the external input coupling capacitor. The value of this capacitor affects the performance of the clamp. If it is too small, there is a significant amplitude change during a horizontal line time (between clamping intervals). If the capacitor is too large, then it takes excessively long for the clamp to recover from a large change in the incoming signal offset. The recommended value (47 nF) results in recovering from a step error of 100 mV

to within ½ LSB in 10 lines with a clamp duration of 20 pixel periods on a 75 Hz SXGA signal.

YUV Clamping

YUV graphic signals are slightly different from RGB signals in that the dc reference level (black level in RGB signals) can be at the midpoint of the graphics signal rather than the bottom. For these signals it can be necessary to clamp to the midscale range of the ADC range (128) rather than the bottom of the ADC range (0).

Clamping to midscale rather than ground can be accomplished by setting the clamp select bits in the serial bus register. Each of the three converters has its own selection bit so that they can be clamped to either midscale or ground independently. These bits are located in Register 0x1B [7:5]. The midscale reference voltage is internally generated for each converter.

Auto-Offset

The auto-offset circuit works by calculating the required offset setting to yield a given output code during clamp. When this block is enabled, the offset setting in the I²C is seen as a desired clamp code rather than an actual offset. The circuit compares the output code during clamp to the desired code and adjusts the offset up or down to compensate.

The offset on the AD9396 can be adjusted automatically to a specified target code. This option allows the user to set the offset to any value and be assured that all channels with the same value programmed into the target code will match. This eliminates any need to adjust the offset at the factory. This function is capable of running continuously any time the clamp is asserted.

There is an offset adjust register for each channel, namely the offset registers at the 0x08, 0x0A, and 0x0C addresses. The offset adjustment is a signed (twos complement) number with ±64 LSB range. The offset adjustment is added to whatever offset the auto-offset comes up with. For example: using ground clamp, the target code is set to 4. To get this code, the auto-offset generates an offset of 68. If the offset adjustment is set to +10, the offset sent to the converter is 78. Likewise, if the offset adjust is set to -10, the offset sent to the converter is 58. [Refer to application note AN-775, Implementing the Auto-Offset Function of the AD9880](#), for a detailed description of how to use this function.

Sync-on-Green (SOG)

The SOG input operates in two steps. First, it sets a baseline clamp level from the incoming video signal with a negative peak detector. Second, it sets the sync trigger level to a programmable level (typically 150 mV) above the negative peak. The SOG input must be ac-coupled to the green analog input through its own capacitor. The value of the capacitor must be 1 nF ± 20%. If SOG is not used, this connection is not required.

Note that the SOG signal is always negative polarity. For more detail on setting the SOG threshold and other SOG-related functions, see the Sync Processing section.

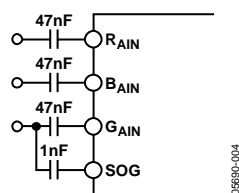

Figure 4. Typical Clamp Configuration for RGB/YUV Applications

Clock Generation

A PLL is employed to generate the pixel clock. In this PLL, the HSYNC input provides a reference frequency. A voltage controlled oscillator (VCO) generates a much higher pixel clock frequency. This pixel clock is divided by the PLL divide value (Register 0x01 and Register 0x02) and phase compared with the HSYNC input. Any error is used to shift the VCO frequency and to maintain the lock between the two signals.

The stability of this clock is a very important element in providing the clearest and most stable image. During each pixel time, there is a period during which the signal slews from the old pixel amplitude and settles at its new value. This is followed by a time when the input voltage is stable before the signal slewed to a new value. The ratio of the slewing time to the stable time is a function of the bandwidth of the graphics DAC and the bandwidth of the transmission system (cable and termination). It is also a function of the overall pixel rate. Clearly, if the dynamic characteristics of the system remain fixed, then the slewing and settling time is likewise fixed. This time must be subtracted from the total pixel period, leaving the stable period. At higher pixel frequencies, the total cycle time is shorter and the stable pixel time also becomes shorter.

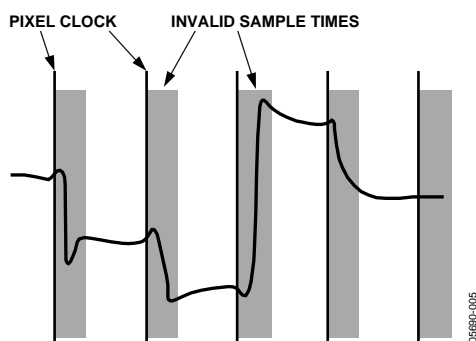

Figure 5. Pixel Sampling Times

Any jitter in the clock reduces the precision with which the sampling time can be determined and must also be subtracted from the stable pixel time. Considerable care has been taken in the design of the AD9396 clock generation circuit to minimize jitter. The clock jitter of the AD9396 is less than 13% of the total pixel time in all operating modes, making the reduction in the valid sampling time due to jitter negligible.

The PLL characteristics are determined by the loop filter design, the PLL charge pump current, and the VCO range setting. The loop filter design is shown in Figure 6. Recommended settings of the VCO range and charge pump current for VESA standard display modes are listed in Table 9.

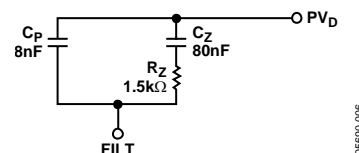

Figure 6. PLL Loop Filter Detail

Four programmable registers are provided to optimize the performance of the PLL. These registers are:

- The 12-bit divisor register (R0x01, R0x02). The input HSYNC frequency range can be any frequency which, combined with the PLL_Div, does not exceed the VCO range. The PLL multiplies the frequency of the HSYNC signal, producing pixel clock frequencies in the range of 10 MHz to 100 MHz. The divisor register controls the exact multiplication factor.
- The 2-bit VCO range register (R0x03). To improve the noise performance of the AD9396, the VCO operating frequency range is divided into four overlapping regions. The VCO range register sets this operating range. The frequency ranges for the lowest and highest regions are shown in Table 7.

Table 7.

VCORNGE	Pixel Rate Range
00	12 to 30
01	30 to 60
10	60 to 120
11	120 to 150

- The 5-bit phase adjust register (R0x05). The phase of the generated sampling clock can be shifted to locate an optimum sampling point within a clock cycle. The phase adjust register provides 32 phase-shift steps of 11.25° each. The HSYNC signal with an identical phase shift is available through the HSOUT pin.

The coast pin or the internal coast is used to allow the PLL to continue to run at the same frequency, in the absence of the incoming HSYNC signal or during disturbances in HSYNC (such as equalization pulses). This can be used during the vertical sync period or any other time that the HSYNC signal is unavailable. The polarity of the coast signal can be set through the coast polarity register. Also, the polarity of the HSYNC signal can be set through the HSYNC polarity register. For both HSYNC and coast, a value of 1 is active high. The internal coast function is driven from the VSYNC signal, which is typically a time when HSYNC signals can be disrupted with extra equalization pulses.

AD9396

Power Management

The AD9396 uses the activity detect circuits, the active interface bits in the serial bus, the active interface override bits, the power-down bit, and the power-down pin to determine the correct power state. There are four power states: full-power, seek mode, auto power-down, and power-down.

Table 8 summarizes how the AD9396 determines the power mode and the circuitry that is powered on/off in each of these modes. The power-down command has priority and then the automatic circuitry. The power-down pin (Pin 81—polarity set

by Register 0x26[3]) can drive the chip into four power-down options. Bit 2 and Bit 1 of Register 0x26 control these four options. Bit 0 controls whether the chip is powered down or the outputs are placed in high impedance mode (with the exception of SOG). Bit 7 to Bit 4 of Register 0x26 control whether the outputs, SOG, Sony Philips digital interface (SPDIF) or I²S (IIS or Inter-IC sound bus) outputs are in high impedance mode or not. See the 2-Wire Serial Control Register Detail section for more detail.

Table 8. Power-Down Mode Descriptions

Mode	Inputs			Power-On or Comments
	Power-Down ¹	Sync Detect ²	Auto PD Enable ³	
Full Power	1	1	X	Everything
Seek Mode	1	0	0	Everything
Seek Mode	1	0	1	Serial bus, sync activity detect, SOG, band gap reference
Power-Down	0	X		Serial bus, sync activity detect, SOG, band gap reference

¹ Power-down is controlled via Bit 0 in Serial Bus Register 0x26.

² Sync detect is determined by OR'ing Bit 7 to Bit 2 in Serial Bus Register 0x15.

³ Auto power-down is controlled via Bit 7 in Serial Bus Register 0x27.

Table 9. Recommended VCO Range and Charge Pump Current Settings for Standard Display Formats

Standard	Resolution	Refresh Rate (Hz)	Horizontal Frequency (kHz)	Pixel Rate (MHz)	VCO Range ¹	Current ¹
VGA	640 × 480	60	31.5	25.175	00	101
		72	37.7	31.500	01	011
		75	37.5	31.500	01	100
		85	43.3	36.000	01	100
SVGA	800 × 600	56	35.1	36.000	01	100
		60	37.9	40.000	01	101
		72	48.1	50.000	01	110
		75	46.9	49.500	01	110
		85	53.7	56.250	01	110
XGA	1024 × 768	60	48.4	65.000	10	011
		70	56.5	75.000	10	100
		75	60.0	78.750	10	100
		80	64.0	85.500	10	101
		85	68.3	94.500	10	110
SXGA	1280 × 1024	60	64.0	108.000	10	110
		75	80.0	135.000	11	110
TV	480i	60	15.75	13.51	00	010
	480p	60	31.47	27	00	101
	720p	60	45	74.25	10	100
	1035i	60	33.75	74.25	10	100
	1080i	60	33.75	74.25	10	100
	1080p	60	67.5	148.5	11	110

¹ These are preliminary recommendations for the analog PLL and are subject to change without notice.

TIMING

The output data clock signal is created so that its rising edge always occurs between data transitions and can be used to latch the output data externally.

There is a pipeline in the AD9396, which must be flushed before valid data becomes available. This means 23 data sets are presented before valid data is available.

The timing diagram in Figure 7 shows the operation of the AD9396.

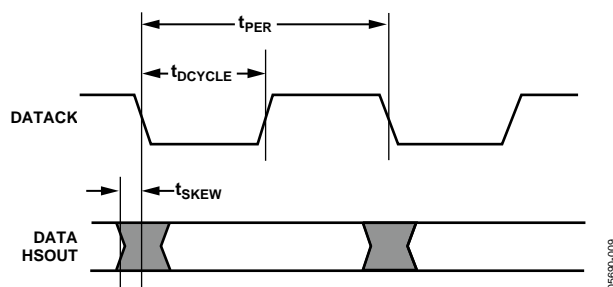

Figure 7. Output Timing

HSYNC Timing

Horizontal sync (HSYNC) is processed in the AD9396 to eliminate ambiguity in the timing of the leading edge with respect to the phase-delayed pixel clock and data.

The HSYNC input is used as a reference to generate the pixel sampling clock. The sampling phase can be adjusted, with respect to HSYNC, through a full 360° in 32 steps via the phase adjust register (to optimize the pixel sampling time). Display systems use HSYNC to align memory and display write cycles, so it is important to have a stable timing relationship between the HSYNC output (HSOUT) and data clock (DATAACK).

Three things happen to HSYNC in the AD9396. First, the polarity of HSYNC input is determined and thus has a known output polarity. The known output polarity can be programmed either active high or active low (Register 0x24, Bit 7). Second, HSOUT is aligned with DATAACK and data outputs. Third, the duration of HSOUT (in pixel clocks) is set via Register 0x23. HSOUT is the sync signal that should be used to drive the rest of the display system.

Coast Timing

In most computer systems, the HSYNC signal is provided continuously on a dedicated wire. In these systems, the coast input and function are unnecessary, and should not be used. The pin should be permanently connected to the inactive state.

In some systems, however, HSYNC is disturbed during the vertical sync period (VSYNC). In some cases, HSYNC pulses disappear. In other systems, such as those that employ composite sync (Csync) signals or embedded SOG, HSYNC includes equalization pulses or other distortions during VSYNC. To avoid upsetting the clock generator during VSYNC, it is important to ignore these distortions. If the pixel clock PLL sees extraneous pulses, it attempts to lock to this new frequency, and changes frequency by the end of the VSYNC period. It then takes a few lines of correct HSYNC timing to recover at the beginning of a new frame, tearing the image at the top of the display.

The coast input is provided to eliminate this problem. It is an asynchronous input that disables the PLL input and allows the clock to free-run at its then-current frequency. The PLL can free-run for several lines without significant frequency drift.

Coast can be generated internally by the AD9396 (see Register 0x12[1]), can be driven directly from a VSYNC input, or can be provided externally by the graphics controller.

Sync Processing

The inputs of the sync processing section of the AD9396 are combinations of digital HSYNCs and VSYNCs, analog sync-on-green, or sync-on-Y signals, and an optional external coast signal. From these signals, it generates a precise, jitter-free (9% or less at 95 MHz) clock from its PLL; an odd/even field signal; HSYNC and VSYNC out signals; a count of HSYNCs per VSYNC; and a programmable SOG output. The main sync processing blocks are the sync slicer, sync separator, HSYNC filter, HSYNC regenerator, VSYNC filter, and coast generator.

The sync slicer extracts the sync signal from the green graphics or luminance video signal that is connected to the SOGIN input and outputs a digital composite sync. The sync separator's task

is to extract VSYNC from the composite sync signal, which can come from either the sync slicer or the HSYNC input. The HSYNC filter is used to eliminate any extraneous pulses from the HSYNC or SOGIN inputs, outputting a clean, low jitter signal that is appropriate for mode detection and clock generation. The HSYNC regenerator is used to re-create a clean, although not low jitter, HSYNC signal that can be used for mode detection and counting HSYNCs per VSYNC. The VSYNC filter is used to eliminate spurious VSYNCs, maintain a stable timing relationship between the VSYNC and HSYNC output signals, and generate the odd/even field output. The coast generator creates a robust coast signal that allows the PLL to maintain its frequency in the absence of HSYNC pulses.

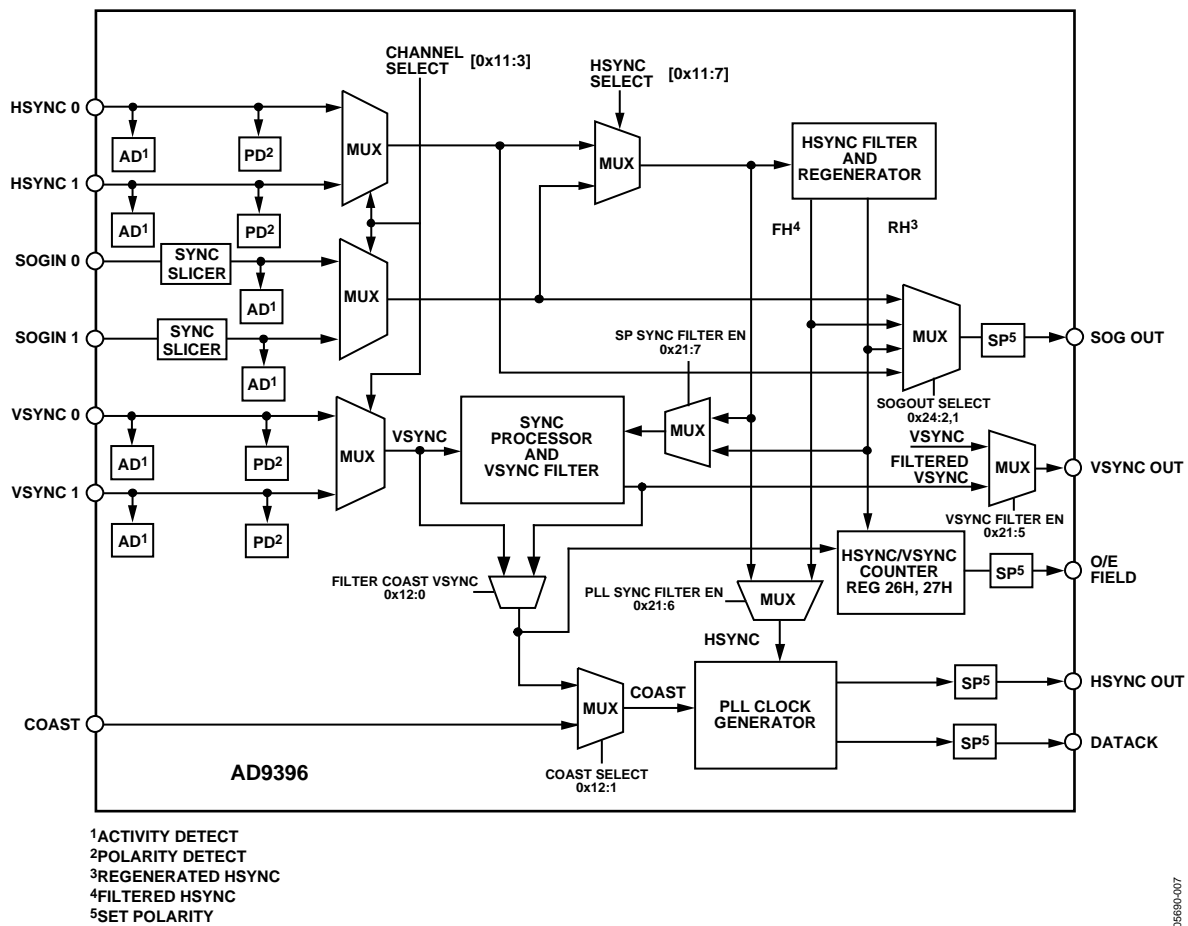

Figure 8. Sync Processing Block Diagram

Sync Slicer

The purpose of the sync slicer is to extract the sync signal from the green graphics or luminance video signal that is connected to the SOGIN input. The sync signal is extracted in a two-step process. First, the SOG input (typically 0.3 V below the black level) is detected and clamped to a known dc voltage. Next, the signal is routed to a comparator with a variable trigger level (set by Register 0x1D, Bits [7:3]), but nominally 0.128 V above the clamped voltage. The sync slicer output is a digital composite sync signal containing both HSYNC and VSYNC information (see Figure 9).

Sync Separator

As part of sync processing, the sync separator's task is to extract VSYNC from the composite sync signal. It works on the idea that the VSYNC signal stays active for a much longer time than the HSYNC signal. By using a digital low-pass filter and a digital comparator, it rejects pulses with small durations (such as HSYNCs and equalization pulses) and only passes pulses with large durations, such as VSYNC (see Figure 9).

The threshold of the digital comparator is programmable for maximum flexibility. To program the threshold duration, write a value (N) to Register 0x11. The resulting pulse width is $N \times 200$ ns. So if $N = 5$, the digital comparator threshold is 1 μ s. Any pulses less than 1 μ s are rejected, while any pulse greater than 1 μ s passes through.

The sync separator on the AD9396 is simply an 8-bit digital counter with a 6 MHz clock. It works independently of the polarity of the composite sync signal. Polarities are determined elsewhere on the chip. The basic idea is that the counter counts up when HSYNC pulses are present. But because HSYNC

pulses are relatively short in width, the counter only reaches a value of N before the pulse ends. It then starts counting down until eventually reaching 0 before the next HSYNC pulse arrives. The specific value of N varies for different video modes, but is always less than 255. For example, with a 1 μ s width HSYNC, the counter only reaches 5 ($1 \mu\text{s}/200 \text{ ns} = 5$). Now, when VSYNC is present on the composite sync the counter also counts up. However, because the VSYNC signal is much longer, it counts to a higher number, M. For most video modes, M is at least 255. So VSYNC can be detected on the composite sync signal by detecting when the counter counts to higher than N. The specific count that triggers detection, T, can be programmed through the Serial Register 0x11.

Once VSYNC has been detected, there is a similar process to detect when it goes inactive. At detection, the counter first resets to 0, then starts counting up when VSYNC finishes. As in the previous case, it detects the absence of VSYNC when the counter reaches the threshold count, T. In this way, it rejects noise and/or serration pulses. Once VSYNC is detected to be absent, the counter resets to 0 and begins the cycle again.

There are two things to keep in mind when using the sync separator. First, the resulting clean VSYNC output is delayed from the original VSYNC by a duration equal to the digital comparator threshold ($N \times 200$ ns). Second, there is some variability to the 200 ns multiplier value. The maximum variability over all operating conditions is $\pm 20\%$ (160 ns to 240 ns). Because normal VSYNC and HSYNC pulse widths differ by a factor of about 500 or more, 20% variability is not an issue.

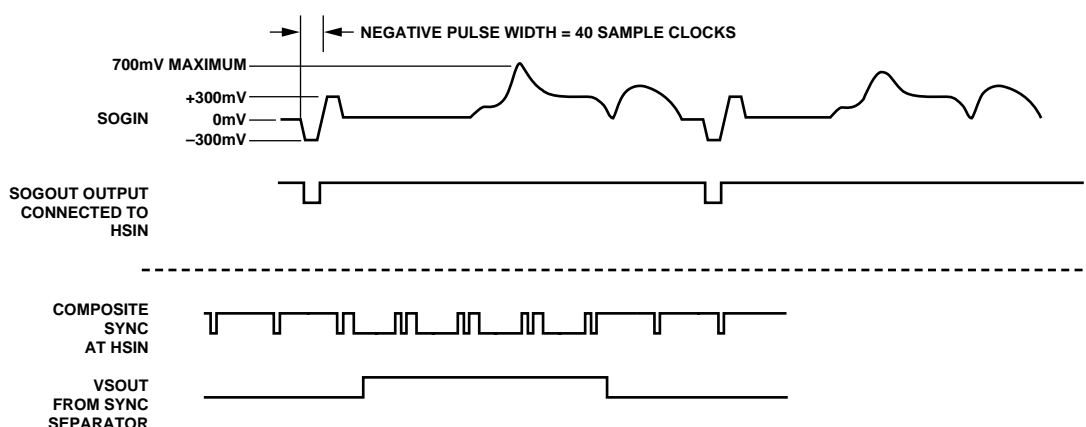

Figure 9. Sync Slicer and Sync Separator Output

HSYNC Filter and Regenerator

The HSYNC filter is used to eliminate any extraneous pulses from the HSYNC or SOGIN inputs, outputting a clean, low jitter signal that is appropriate for mode detection and clock generation. The HSYNC regenerator is used to re-create a clean, although not low jitter, HSYNC signal that can be used for mode detection and counting HSYNCs per VSYNC. The HSYNC regenerator has a high degree of tolerance to extraneous and missing pulses on the HSYNC input, but is not appropriate for use by the PLL in creating the pixel clock because of jitter.

The HSYNC regenerator runs automatically and requires no setup to operate. The HSYNC filter requires setting up a filter window. The filter window sets a periodic window of time around the regenerated HSYNC leading edge where valid HSYNCs are allowed to occur. The general idea is that extraneous pulses on the sync input occur outside of this filter window and thus are filtered out. To set the filter window

timing, program a value (x) into Register 0x20. The resulting filter window time is $\pm x$ times 25 ns around the regenerated HSYNC leading edge. Just as for the sync separator threshold multiplier, allow a $\pm 20\%$ variance in the 25 ns multiplier to account for all operating conditions (20 ns to 30 ns range).

A second output from the HSYNC filter is a status bit (Register 0x16[0]) that tells whether extraneous pulses are present on the incoming sync signal. Extraneous pulses are often included for copy protection purposes; this status bit can be used to detect that.

The filtered HSYNC (rather than the raw HSYNC/SOGIN signal) for pixel clock generation by the PLL is controlled by Register 0x21[6]. The regenerated HSYNC (rather than the raw HSYNC/SOGIN signal) for sync processing is controlled by Register 0x21[7]. Use of the filtered HSYNC and regenerated HSYNC is recommended. See Figure 10 for an illustration of a filtered HSYNC.

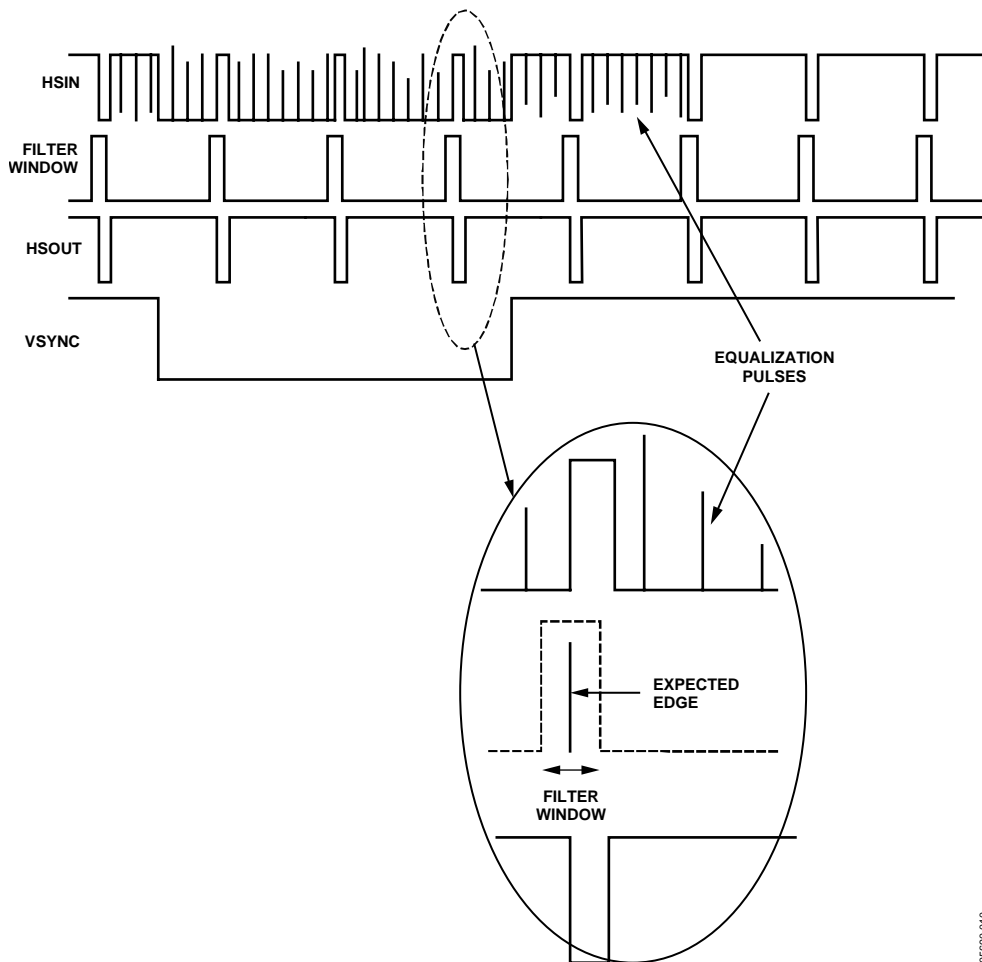

Figure 10. Sync Processing Filter

05690-010

VSYNC Filter and Odd/Even Fields

The VSYNC filter is used to eliminate spurious VSYNCs, maintain a consistent timing relationship between the VSYNC and HSYNC output signals, and generate the odd/even field output.

The filter works by examining the placement of VSYNC with respect to HSYNC and, if necessary, slightly shifting it in time at the VSOUT output. The goal is to keep the VSYNC and HSYNC leading edges from switching at the same time, eliminating confusion as to when the first line of a frame occurs. Enabling the VSYNC filter is done with Register 0x21[5]. Use of the VSYNC filter is recommended for all cases, including interlaced video and is required when using the HSYNC per VSYNC counter. Figure 12 illustrates even/odd field determination in two situations.

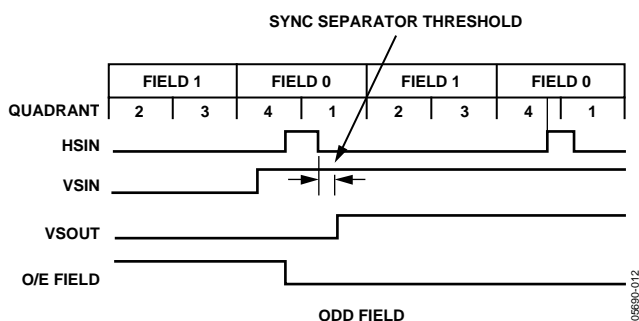
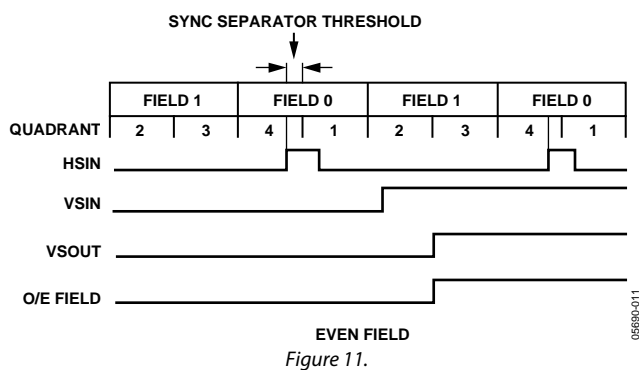

Figure 12. VSYNC Filter—Odd/Even

DVI RECEIVER

The DVI receiver section of the AD9396 allows the reception of a digital video stream compatible with DVI 1.0. Embedded in this data stream are HSYNCs, VSYNCs and display enable (DE) signals. DVI restricts the received format to RGB, but the inclusion of a programmable color space converter (CSC) allows the output to be tailored to any format necessary. With this, the scaler following the AD9396 can specify that it always wishes to receive a particular format—for instance, 4:2:2 YCrCb—regardless of the transmitted mode. If RGB is sent, the CSC can easily convert that to 4:2:2 YCrCb while relieving the scaler of this task.

DE GENERATOR

The AD9396 has an on-board generator for DE, for start of active video (SAV), and for end of active video (EAV), all of which are necessary for describing the complete data stream for a BT656-compatible output. In addition to this particular output, it is possible to generate the DE for cases in which a scaler is not used. This signal alerts the following circuitry as to which are displayable video pixels.

4:4:4 TO 4:2:2 FILTER

The AD9396 contains a filter that allows it to convert a signal from YCrCb 4:4:4 to YCrCb 4:2:2 while maintaining the maximum accuracy and fidelity of the original signal.

Input Color Space to Output Color space

The AD9396 can support a wide variety of output formats, such as the following:

- RGB 24-bit
- 4:4:4 YCrCb 8-bit
- 4:2:2 YCrCb 8-bit, 10-bit, and 12-bit
- Dual 4:2:2 YCrCb 8-bit

Color Space Conversion (CSC) Matrix

The color space conversion (CSC) matrix in the AD9396 consists of three identical processing channels. In each channel, three input values are multiplied by three separate coefficients. Also included are an offset value for each row of the matrix and a scaling multiple for all values. Each value has a 13-bit, two's complement resolution to ensure the signal integrity is maintained. The CSC is designed to run at speeds up to 150 MHz supporting resolutions up to 1080p at 60 Hz. With any-to-any color space support, formats such as RGB, YUV, YCbCr, and others are supported by the CSC.

The main inputs, R_{IN} , G_{IN} , and B_{IN} come from the 8-bit to 12-bit inputs from each channel. These inputs are based on the input format detailed in Table 11. The mapping of these inputs to the CSC inputs is shown in Table 10.

Table 10. CSC Port Mapping

Input Channel	CSC Input Channel
R/CR	R_{IN}
Gr/Y	G_{IN}
B/CB	B_{IN}

One of the three channels is represented in Figure 13. In each processing channel the three inputs are multiplied by three separate coefficients marked a_1 , a_2 , and a_3 . These coefficients are divided by 4096 to obtain nominal values ranging from -0.9998 to $+0.9998$. The variable labeled 'a4' is used as an offset control. The CSC_Mode setting is the same for all three processing channels. This multiplies all coefficients and offsets by a factor of 2^{CSC_Mode} .

AD9396

The functional diagram for a single channel of the CSC, as shown in Figure 13, is repeated for the remaining G and B channels. The coefficients for these channels are b1, b2, b3, b4, c1, c2, c3, and c4.

A programming example and register settings for several common conversions are listed in the Color Space Converter (CSC) Common Settings.

For a detailed functional description and more programming examples, refer to the application note [AN-795, AD9880 Color Space Converter User's Guide](#).

TIMING DIAGRAMS

The following timing diagrams show the operation of the AD9396. The output data clock signal is created so that its rising edge always occurs between data transitions and can be used to

latch the output data externally. There is a pipeline in the AD9396, which must be flushed before valid data becomes available. This means six data sets are presented before valid data is available.

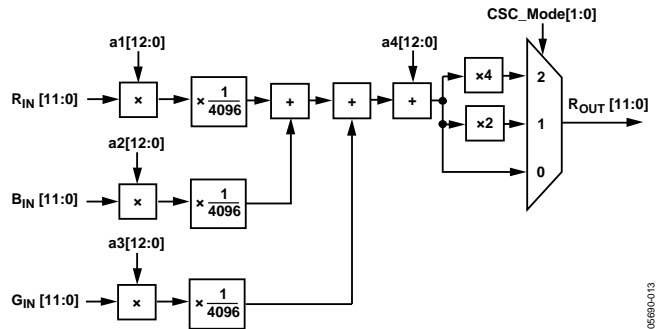

Figure 13. Single CSC Channel

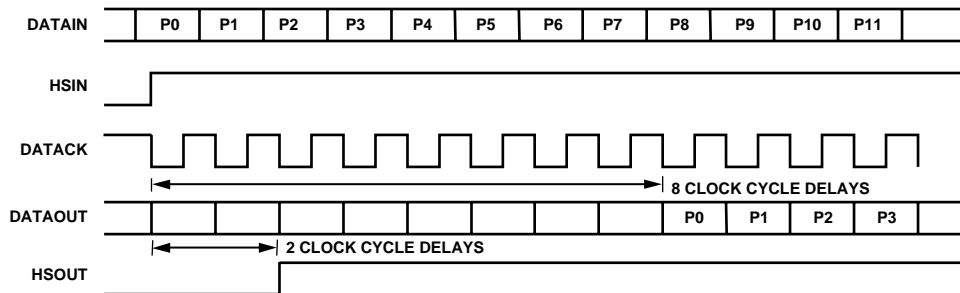
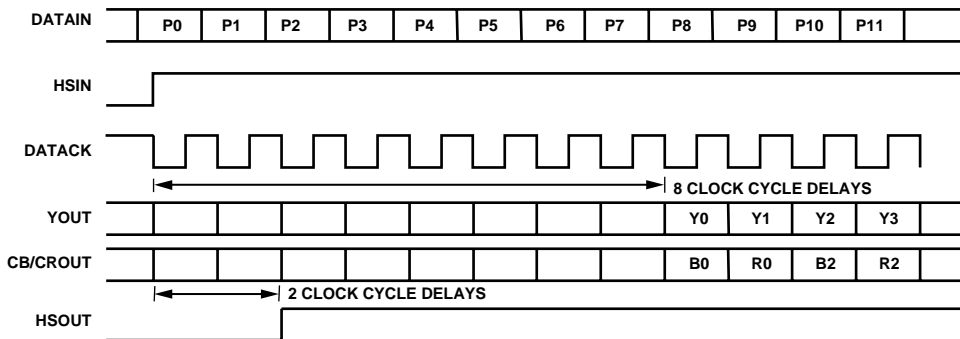

Figure 14. RGB ADC Timing



- NOTES:
 1. PIXEL AFTER HSOUT CORRESPONDS TO BLUE INPUT.
 2. EVEN NUMBER OF PIXEL DELAYS BETWEEN HSOUT AND DATAOUT.

Figure 15. YCrCb ADC Timing

Table 11.

Port	Red								Green								Blue							
Bit	7	6	5	4	3	2	1	0	7	6	5	4	3	2	1	0	7	6	5	4	3	2	1	0
4:4:4	Red/Cr [7:0]								Green/Y [7:0]								Blue/Cb [7:0]							
4:2:2	CbCr [7:0]								Y [7:0]								DDR 4:2:2 ↑ CbCr ↓ Y, Y							
4:4:4 DDR	DDR ↑ ¹ G [3:0]				DDR ↑ B [7:4]				DDR ↑ B [3:0]				DDR 4:2:2 ↑ CbCr [11:0]											
	DDR ↓ R [7:0]								DDR ↓ G [7:4]								DDR 4:2:2 ↓ Y, Y [11:0]							
4:2:2 to 12	CbCr [11:0]								Y [11:0]															

¹ Arrows in the table indicate clock edge. Rising edge of clock = ↑, falling edge = ↓.

2-WIRE SERIAL REGISTER MAP

The AD9396 is initialized and controlled by a set of registers that determines the operating modes. An external controller is employed to write and read the control registers through the 2-wire serial interface port.

Table 12. Control Register Map

Hex Address	Read/Write or Read Only	Bits	Default Value	Register Name	Description
0x00	Read	[7:0]	00000000	Chip Revision	Chip revision ID.
0x01	Read/Write	[7:0]	01101001	PLL Divider MSB	PLL feedback divider value MSB.
0x02	Read/Write	[7:4]	1101****	PLL Divider	PLL feedback divider value.
0x03	Read/Write	[7:6] [5:3] [2]	01***** **001*** *****0**	VCO Range Charge Pump External Clock Enable	VCO range. Charge pump current control for PLL. Selects the external clock input rather than the internal PLL clock.
0x04	Read/Write	[7:3]	10000***	Phase Adjust	Selects the clock phase to use for the ADC clock.
0x05	Read/Write	[7:0]	10000000	Red Gain	Controls the gain of the red channel PGA. 0 = low gain, 255 = high gain.
0x06	Read/Write	[7:0]	10000000	Green Gain	Controls the gain of the green channel PGA. 0 = low gain, 255 = high gain.
0x07	Read/Write	[7:0]	10000000	Blue Gain	Controls the gain of the blue channel PGA. 0 = low gain, 255 = high gain.
0x08	Read/Write	[7:0]	00000000	Red Offset Adjust	User adjustment of auto-offset. Allows user control of brightness.
0x09	Read/Write	[7:0]	10000000	Red Offset	Red offset/target code. 0 = small offset, 255 = large offset.
0x0A	Read/Write	[7:0]	00000000	Green Offset Adjust	User adjustment of auto-offset. Allows user control of brightness.
0x0B	Read/Write	[7:0]	10000000	Green Offset	Green offset/target code. 0 = small offset, 255 = large offset.
0x0C	Read/Write	[7:0]	00000000	Blue Offset Adjust	User adjustment of auto-offset. Allows user control of brightness.
0x0D	Read/Write	[7:0]	10000000	Blue Offset	Blue offset/target code. 0 = small offset, 255 = large offset.
0x0E	Read/Write	[7:0]	00100000	Sync Separator Threshold	Selects the maximum HSYNC pulse width for composite sync separation.
0x0F	Read/Write	[7:2]	010000**	SOG Comparator Threshold Enter	The enter level for the SOG slicer. Must be less than or equal to the exit level.
0x10	Read/Write	[7:2]	010000**	SOG Comparator Threshold Exit	The exit level for the SOG slicer. Must be greater than or equal to the enter level.
0x11	Read/Write	[7] [6] [5] [4] [3] [2] [1] [0]	0***** *0***** **0***** ***0**** ****0*** ****0*** *****0* *****0	HSYNC Source HSYNC Source Override VSYNC Source VSYNC Source Override Channel Select Channel Select Override Interface Select Interface Override	0 = HSYNC. 1 = SOG. 0 = auto HSYNC source. 1 = manual HSYNC source. 0 = VSYNC. 1 = VSYNC from SOG. 0 = auto HSYNC source. 1 = manual HSYNC source. 0 = Channel 0. 1 = Channel 1. 0 = autochannel select. 1 = manual channel select. 0 = analog interface. 1 = digital interface. 0 = auto-interface select. 1 = manual interface select.

AD9396

Hex Address	Read/Write or Read Only	Bits	Default Value	Register Name	Description
0x12	Read/Write	[7]	1*****	Input HSYNC Polarity	0 = active low. 1 = active high.
		[6]	*0*****	HSYNC Polarity Override	0 = auto HSYNC polarity. 1 = manual HSYNC polarity.
		[5]	**1*****	Input VSYNC Polarity	0 = active low. 1 = active high.
		[4]	***0****	VSYNC Polarity Override	0 = auto VSYNC polarity. 1 = manual VSYNC polarity.
		[3]	****1***	Input Coast Polarity	0 = active low. 1 = active high.
		[2]	*****0**	Coast Polarity Override	0 = auto-coast polarity. 1 = manual coast polarity.
		[1]	*****0*	Coast Source	0 = internal coast. 1 = external coast.
		[0]	*****1	Filter Coast VSYNC	0 = Use raw VSYNC for coast generation. 1 = Use filtered VSYNC for coast generation.
0x13	Read/Write	[7:0]	00000000	Precoast	Number of HSYNC periods before VSYNC to coast.
0x14	Read/Write	[7:0]	00000000	Postcoast	Number of HSYNC periods after VSYNC to coast.
0x15	Read	[7]	0*****	HSYNC 0 Detected	0 = not detected. 1 = detected.
		[6]	*0*****	HSYNC 1 Detected	0 = not detected. 1 = detected.
		[5]	**0*****	VSYNC 0 Detected	0 = not detected. 1 = detected.
		[4]	***0****	VSYNC 1 Detected	0 = not detected. 1 = detected.
		[3]	****0***	SOG 0 Detected	0 = not detected. 1 = detected.
		[2]	*****0**	SOG1 Detected	0 = not detected. 1 = detected.
		[1]	*****0*	Coast Detected	0 = not detected. 1 = detected.
0x16	Read	[7]	0*****	HSYNC 0 Polarity	0 = active low. 1 = active high.
		[6]	*0*****	HSYNC 1 Polarity	0 = active low. 1 = active high.
		[5]	**0*****	VSYNC 0 Polarity	0 = active low. 1 = active high.
		[4]	***0****	VSYNC 1 Polarity	0 = active low. 1 = active high.
		[3]	****0***	Coast Polarity	0 = active low. 1 = active high.
		[2]	*****0**	Pseudo Sync Detected	0 = not detected. 1 = detected.
		[1]	*****0*	Sync Filter Locked	0 = not locked. 1 = locked.

Hex Address	Read/Write or Read Only	Bits	Default Value	Register Name	Description
		[0]	*****0	Bad Sync Detect	0 = not detected. 1 = detected.
0x17	Read	[3:0]	****0000	HSYNCS per VSYNC MSB	MSB of HSYNCS per VSYNC.
0x18	Read	[7:0]	00000000	HSYNCS per VSYNC	HSYNCS per VSYNC count.
0x19	Read/Write	[7:0]	00001000	Clamp Placement	Number of pixel clocks after trailing edge of HSYNC to begin clamp.
0x1A	Read/Write	[7:0]	00010100	Clamp Duration	Number of pixel clocks to clamp.
0x1B	Read/Write	[7]	0*****	Red Clamp Select	0 = clamp to ground. 1 = clamp to midscale.
		[6]	*0*****	Green Clamp Select	0 = clamp to ground. 1 = clamp to midscale.
		[5]	**0*****	Blue Clamp Select	0 = clamp to ground. 1 = clamp to midscale.
		[4]	***0****	Clamp During Coast Enable	0 = don't clamp during coast. 1 = clamp during coast.
		[3]	****0***	Clamp Disable	0 = internal clamp enabled. 1 = internal clamp disabled.
		[1]	*****1*	Programmable Bandwidth	0 = low bandwidth. 1 = full bandwidth.
0x1C	Read/Write	[7]	0*****	Auto-Offset Enable	0 = manual offset. 1 = auto-offset using offset as target code.
		[6:5]	*10*****	Auto-Offset Update Mode	00 = every clamp. 01 = every 16 clamps. 10 = every 64 clamps. 11 = every VSYNC.
		[4:3]	***01***	Difference Shift Amount	00 = 100% of difference used to calculate new offset. 01 = 50%. 10 = 25%. 11 = 12.5%.
		[2]	*****1**	Auto Jump Enable	0 = normal operation. 1 = if code > 15 codes off, offset is jumped to the predicted offset necessary to fix the >15 code mismatch.
		[1]	*****1*	Post Filter Enable	0 = disable post filter. 1 = enable post filter. Post filter reduces update rate by 1/6 and requires that all six updates recommend a change before changing the offset. This prevents unwanted offset changes.
[0]	*****0	Toggle Filter Enable	The toggle filter looks for the offset to toggle back and forth and holds it if triggered. This prevents toggling in case of missing codes in the PGA.		
0x1D	Read/Write	[7:0]	00001000	Slew Limit	Limits the amount the offset can change by in a single update.
0x1E	Read/Write	[7:0]	32	Sync Filter Lock Threshold	Number of clean HSYNCS required for sync filter to lock.
0x1F	Read/Write	[7:0]	50	Sync Filter Unlock Threshold	Number of missing HSYNCS required to unlock the sync filter. Counter counts up if HSYNC pulse is missing and down for a good HSYNC.
0x20	Read/Write	[7:0]	50	Sync Filter Window Width	Width of the window in which HSYNC pulses are allowed.

AD9396

Hex Address	Read/Write or Read Only	Bits	Default Value	Register Name	Description
0x21	Read/Write	[7]	1*****	SP Sync Filter Enable	Enables coast, VSYNC duration, and VSYNC filter to use the regenerated HSYNC rather than the raw HSYNC.
		[6]	*1*****	PLL Sync Filter Enable	Enables the PLL to use the filtered HSYNC rather than the raw HSYNC. This clips any bad HSYNCs, but does not regenerate missing pulses.
		[5]	**0*****	VSYNC Filter Enable	Enables the VSYNC filter. The VSYNC filter gives a predictable HSYNC/VSYNC timing relationship but clips one HSYNC period off the leading edge of VSYNC.
		[4]	***0****	VSYNC Duration Enable	Enables the VSYNC duration block. This block can be used if necessary to restore the duration of a filtered VSYNC.
		[3]	**** 1***	Auto-Offset Clamp Mode	0 = auto-offset measures code during clamp. 1 = auto-offset measures code (10 or 16) clock cycles after end of clamp for 6 clock cycles.
		[2]	**** *1**	Auto-Offset Clamp Length	Sets delay after end of clamp for auto-offset clamp mode = 1. 0 = delay is 10 clock cycles. 1 = delay is 16 clock cycles.
0x22	Read/Write	[7:0]	4	VSYNC Duration	VSYNC duration.
0x23	Read/Write	[7:0]	32	HSYNC Duration	HSYNC duration. Sets the duration of the output HSYNC in pixel clocks.
0x24	Read/Write	[7]	1*****	HSYNC Output Polarity	Output HSYNC polarity (both DVI and analog). 0 = active low out. 1 = active high out.
		[6]	*1*****	VSYNC Output Polarity	Output VSYNC polarity (both DVI and analog). 0 = active low out. 1 = active high out.
		[5]	**1*****	DE Output Polarity	Output DE polarity (both DVI and analog). 0 = active low out. 1 = active high out.
		[4]	***1****	Field Output Polarity	Output field polarity (both DVI and analog). 0 = active low out. 1 = active high out.
		[3]	****1***	SOG Output Polarity	Output SOG polarity (analog only). 0 = active low out. 1 = active high out.
		[2:1]	*****11*	SOG Output Select	Selects signal present on SOG output. 00 = SOG (SOG0 or SOG1). 01 = raw HSYNC (HSYNC0 or HSYNC1). 10 = regenerated sync. 11 = HSYNC to PLL.
		[0]	*****0	Output CLK Invert	0 = don't invert clock out. 1 = invert clock out.
0x25	Read/Write	[7:6]	01*****	Output CLK Select	Selects which clock to use on output pin. 1× CLK is divided down from TMDS clock input when pixel repetition is in use. 00 = ½× CLK. 01 = 1× CLK. 10 = 2× CLK. 11 = 90° phase 1× CLK.
		[5:4]	**11****	Output Drive Strength	Sets the drive strength of the outputs. 00 = lowest, 11 = highest.

Hex Address	Read/Write or Read Only	Bits	Default Value	Register Name	Description
		[3:2]	****00**	Output Mode	Selects which pins the data comes out on. 00 = 4:4:4 mode (normal). 01 = 4:2:2 + DDR 4:2:2 on blue. 10 = DDR 4:4:4 + DDR 4:2:2 on blue.
		[1]	*****1*	Primary Output Enable	Enables primary output.
		[0]	*****0	Secondary Output Enable	Enables secondary output (DDR 4:2:2 in Output Mode 1 and Mode 2).
0x26	Read/Write	[7]	0*****	Output Three-State	Three-states the outputs.
		[6]	*0*****	SOG Three-State	Three-states the SOG output.
		[3]	****1***	Power-Down Pin Polarity	Sets polarity of power-down pin. 0 = active low. 1 = active high. Selects the function of the power-down pin. 00 = power-down. 01 = power-down and three-state SOG. 10 = three-state outputs only. 11 = three-state outputs and SOG.
		[2:1]	****00*	Power-Down Pin Function	
		[0]	*****0	Power-Down	0 = normal. 1 = power-down.
0x27	Read/Write	[7]	1*****	Auto Power-Down Enable	0 = disable auto low power state. 1 = enable auto low power state.
		[6]	*0*****	HDCP A0	Sets the LSB of the address of the HDCP I ² C. Set to 1 only for a second receiver in a dual-link configuration. 0 = use internally generated MCLK. 1 = use external MCLK input.
		[4]	***0****	BT656 EN	Enables EAV/SAV codes to be inserted into the video output data.
		[3]	***0***	Force DE Generation	Allows use of the internal DE generator in DVI mode.
		[2:0]	****000	Interlace Offset	Sets the difference (in HSYNCs) in field length between Field 0 and Field 1.
0x28	Read/Write	[7:2]	011000**	VS Delay	Sets the delay (in lines) from VSYNC leading edge to the start of active video.
		[1:0]	*****01	HS Delay MSB	MSB, Register 0x29.
0x29	Read/Write	[7:0]	00000100	HS Delay	Sets the delay (in pixels) from HSYNC leading edge to the start of active video.
0x2A	Read/Write	[3:0]	****0101	Line Width MSB	MSB, Register 0x2B.
0x2B	Read/Write	[7:0]	00000000	Line Width	Sets the width of the active video line (in pixels).
0x2C	Read/Write	[3:0]	****0010	Screen Height MSB	MSB, Register 0x2D.
0x2D	Read/Write	[7:0]	11010000	Screen Height	Sets the height of the active screen (in lines).
0x2E	Read/Write	[7]	0*****	Test 1	Must be written to 1 for proper operation.
0x2F	Read	[6]	*0*****	TMDS Sync Detect	Detects a TMDS DE.
		[5]	**0*****	TMDS Active	Detects a TMDS clock.
		[3]	****0***	HDCP Keys Read	Returns 1 when read of EEPROM keys is successful.
		[2:0]	****000	DVI Quality	Returns quality number based on DE edges.

AD9396

Hex Address	Read/Write or Read Only	Bits	Default Value	Register Name	Description
0x30	Read	[6]	*0*****	DVI Content Encrypted	This bit is high when HDCP decryption is in use (content is protected). The signal goes low when HDCP is not being used. Customers can use this bit to determine whether to allow copying of the content. The bit should be sampled at regular intervals because it can change on a frame by frame basis.
		[5]	**0*****	DVI HSYNC Polarity	Returns DVI HSYNC polarity.
		[4]	***0****	DVI VSYNC Polarity	Returns DVI VSYNC polarity.
0x31	Read/Write	[7:4]	1001****	MV Pulse Max	Sets the maximum pseudo sync pulse width for Macrovision detection.
		[3:0]	****0110	MV Pulse Min	Sets the minimum pseudo sync pulse width for Macrovision detection.
0x32	Read/Write	[7]	0*****	MV Oversample En	Tells the Macrovision detection engine whether oversampling is in use.
		[6]	*0*****	MV Pal En	Tells the Macrovision detection engine to enter PAL mode.
		[5:0]	**001101	MV Line Count Start	Sets the start line for Macrovision detection.
0x33	Read/Write	[7]	1*****	MV Detect Mode	0 = standard definition. 1 = progressive scan mode.
		[6]	*0*****	MV Settings Override	0 = use hard coded settings for line counts and pulse widths. 1 = use I ² C values for these settings.
		[5:0]	**010101	MV Line Count End	Sets the end line for Macrovision detection.
0x34	Read/Write	[7:6]	10*****	MV Pulse Limit Set	Sets the number of pulses required in the last 3 lines (SD mode only).
		[5]	**0*****	Low Freq Mode	Sets whether the Audio PLL is in low frequency mode. Low frequency mode should only be set for pixel clocks <80 MHz.
		[4]	***0****	Low Freq Override	Allows the previous bit to be used to set low frequency mode rather than the internal auto-detect.
		[3]	****0***	Up Conversion Mode	0 = repeat Cr and Cb values. 1 = interpolate Cr and Cb values.
		[2] [1]	*****0** *****0*	CrCb Filter Enable CSC_Enable	Enables the FIR filter for 4:2:2 CrCb output. Enables the color space converter (CSC). The default settings for the CSC provide HDTV-to-RGB conversion. Sets the fixed point position of the CSC coefficients, including the A4, B4, and C4 offsets.
0x35	Read/Write	[6:5]	*01* ****	CSC_Mode	00 = ±1.0, -4096 to +4095. 01 = ±2.0, -8192 to +8190. 1× = ±4.0, -16384 to +16380.
		[4:0]	***01100	CSC_Coeff_A1 MSB	MSB, Register 0x36.
0x36	Read/Write	[7:0]	01010010	CSC_Coeff_A1	Color space converter (CSC) coefficient for equation: $R_{OUT} = (A1 \times R_{IN}) + (A2 \times G_{IN}) + (A3 \times B_{IN}) + A4$ $G_{OUT} = (B1 \times R_{IN}) + (B2 \times G_{IN}) + (B3 \times B_{IN}) + B4$ $B_{OUT} = (C1 \times R_{IN}) + (C2 \times G_{IN}) + (C3 \times B_{IN}) + C4$
0x37	Read/Write	[4:0]	***01000	CSC_Coeff_A2 MSB	MSB, Register 0x38.
0x38	Read/Write	[7:0]	00000000	CSC_Coeff_A2 LSB	CSC coefficient for equation: $R_{OUT} = (A1 \times R_{IN} + (A2 \times G_{IN}) + (A3 \times B_{IN}) + A4$ $G_{OUT} = (B1 \times R_{IN}) + (B2 \times G_{IN}) + (B3 \times B_{IN}) + B4$ $B_{OUT} = (C1 \times R_{IN}) + (C2 \times G_{IN}) + (C3 \times B_{IN}) + C4$

Hex Address	Read/Write or Read Only	Bits	Default Value	Register Name	Description
0x39	Read/Write	[4:0]	***00000	CSC_Coeff_A3 MSB	MSB, Register 0x3A.
0x3A	Read/Write	[7:0]	00000000	CSC_Coeff_A3 LSB	CSC coefficient for equation: $R_{OUT} = (A1 \times R_{IN}) + (A2 \times G_{IN}) + (A3 \times B_{IN}) + A4$ $G_{OUT} = (B1 \times R_{IN}) + (B2 \times G_{IN}) + (B3 \times B_{IN}) + B4$ $B_{OUT} = (C1 \times R_{IN}) + (C2 \times G_{IN}) + (C3 \times B_{IN}) + C4$
0x3B	Read/Write	[4:0]	***11001	CSC_Coeff_A4 MSB	MSB, Register 0x3C.
0x3C	Read/Write	[7:0]	11010111	CSC_Coeff_A4 LSB	CSC coefficient for equation: $R_{OUT} = (A1 \times R_{IN}) + (A2 \times G_{IN}) + (A3 \times B_{IN}) + A4$ $G_{OUT} = (B1 \times R_{IN}) + (B2 \times G_{IN}) + (B3 \times B_{IN}) + B4$ $B_{OUT} = (C1 \times R_{IN}) + (C2 \times G_{IN}) + (C3 \times B_{IN}) + C4$
0x3D	Read/Write	[4:0]	***11100	CSC_Coeff_B1 MSB	MSB, Register 0x3E.
0x3E	Read/Write	[7:0]	01010100	CSC_Coeff_B1 LSB	CSC coefficient for equation: $R_{OUT} = (A1 \times R_{IN}) + (A2 \times G_{IN}) + (A3 \times B_{IN}) + A4$ $G_{OUT} = (B1 \times R_{IN}) + (B2 \times G_{IN}) + (B3 \times B_{IN}) + B4$ $B_{OUT} = (C1 \times R_{IN}) + (C2 \times G_{IN}) + (C3 \times B_{IN}) + C4$
0x3F	Read/Write	[4:0]	***01000	CSC_Coeff_B2 MSB	MSB, Register 0x40.
0x40	Read/Write	[7:0]	00000000	CSC_Coeff_B2 LSB	CSC coefficient for equation: $R_{OUT} = (A1 \times R_{IN}) + (A2 \times G_{IN}) + (A3 \times B_{IN}) + A4$ $G_{OUT} = (B1 \times R_{IN}) + (B2 \times G_{IN}) + (B3 \times B_{IN}) + B4$ $B_{OUT} = (C1 \times R_{IN}) + (C2 \times G_{IN}) + (C3 \times B_{IN}) + C4$
0x41	Read/Write	[4:0]	***11110	CSC_Coeff_B3 MSB	MSB, Register 0x42.
0x42	Read/Write	[7:0]	10001001	CSC_Coeff_B3 LSB	CSC coefficient for equation: $R_{OUT} = (A1 \times R_{IN}) + (A2 \times G_{IN}) + (A3 \times B_{IN}) + A4$ $G_{OUT} = (B1 \times R_{IN}) + (B2 \times G_{IN}) + (B3 \times B_{IN}) + B4$ $B_{OUT} = (C1 \times R_{IN}) + (C2 \times G_{IN}) + (C3 \times B_{IN}) + C4$
0x43	Read/Write	[4:0]	***00010	CSC_Coeff_B4 MSB	MSB, Register 0x44.
0x44	Read/Write	[7:0]	10010010	CSC_Coeff_B4 LSB	CSC coefficient for equation: $R_{OUT} = (A1 \times R_{IN}) + (A2 \times R_{IN}) + (A3 \times B_{IN}) + A4$ $G_{OUT} = (B1 \times R_{IN}) + (B2 \times G_{IN}) + (B3 \times B_{IN}) + B4$ $B_{OUT} = (C1 \times R_{IN}) + (C2 \times G_{IN}) + (C3 \times B_{IN}) + C4$
0x45	Read/Write	[4:0]	***00000	CSC_Coeff_C1 MSB	MSB, Register 0x46.
0x46	Read/Write	[7:0]	00000000	CSC_Coeff_C1 LSB	CSC coefficient for equation: $R_{OUT} = (A1 \times R_{IN}) + (A2 \times G_{IN}) + (A3 \times B_{IN}) + A4$ $G_{OUT} = (B1 \times R_{IN}) + (B2 \times G_{IN}) + (B3 \times B_{IN}) + B4$ $B_{OUT} = (C1 \times R_{IN}) + (C2 \times G_{IN}) + (C3 \times B_{IN}) + C4$
0x47	Read/Write	[4:0]	***01000	CSC_Coeff_C2 MSB	MSB, Register 0x48.
0x48	Read/Write	[7:0]	00000000	CSC_Coeff_C2 LSB	CSC coefficient for equation: $R_{OUT} = (A1 \times R_{IN}) + (A2 \times G_{IN}) + (A3 \times B_{IN}) + A4$ $G_{OUT} = (B1 \times R_{IN}) + (B2 \times G_{IN}) + (B3 \times B_{IN}) + B4$ $B_{OUT} = (C1 \times R_{IN}) + (C2 \times G_{IN}) + (C3 \times B_{IN}) + C4$
0x49	Read/Write	[4:0]	***01110	CSC_Coeff_C3 MSB	MSB, Register 0x4A.
0x4A	Read/Write	[7:0]	10000111	CSC_Coeff_C3 LSB	CSC coefficient for equation: $R_{OUT} = (A1 \times R_{IN}) + (A2 \times G_{IN}) + (A3 \times B_{IN}) + A4$ $G_{OUT} = (B1 \times R_{IN}) + (B2 \times G_{IN}) + (B3 \times B_{IN}) + B4$ $B_{OUT} = (C1 \times R_{IN}) + (C2 \times G_{IN}) + (C3 \times B_{IN}) + C4$

AD9396

Hex Address	Read/Write or Read Only	Bits	Default Value	Register Name	Description
0x4B	Read/Write	[4:0]	***11000	CSC_Coeff_C4 MSB	MSB, Register 0x4C.
0x4C	Read/Write	[7:0]	10111101	CSC_Coeff_C4 LSB	CSC coefficient for equation: $R_{OUT} = (A1 \times R_{IN}) + (A2 \times G_{IN}) + (A3 \times B_{IN}) + A4$ $G_{OUT} = (B1 \times R_{IN}) + (B2 \times G_{IN}) + (B3 \times B_{IN}) + B4$ $B_{OUT} = (C1 \times R_{IN}) + (C2 \times G_{IN}) + (C3 \times B_{IN}) + C4$
0x50	Read/Write	[7:0]	00100000		Must be written to 0x20 for proper operation.
0x56	Read/Write	[7:0]	00001111		Must be written to default 0x0F for proper operation.
0x59	Read/Write	[6] [5] [4] [0]		MDA/MCL PU CLK Term O/R Manual CLK Term MDA/MCL Three-State	This disables the MDA/MCL pull-ups. Clock termination power-down override: 0 = auto, 1 = manual. Clock termination: 0 = normal, 1 = disconnected. This bit three-states the MDA/MCL lines.

2-WIRE SERIAL CONTROL REGISTER DETAILS

CHIP IDENTIFICATION

0x00—Bits[7:0] Chip Revision

An 8-bit value that reflects the current chip revision.

PLL DIVIDER CONTROL

0x01—Bits[7:0] PLL Divide Ratio MSBs

The eight most significant bits of the 12-bit PLL divide ratio PLLDIV.

The PLL derives a pixel clock from the incoming HSYNC signal. The pixel clock frequency is then divided by an integer value such that the output is phase locked to HSYNC. This PLLDIV value determines the number of pixel times (pixels plus horizontal blanking overhead) per line. This is typically 20% to 30% more than the number of active pixels in the display.

The 12-bit value of the PLL divider supports divide ratios from 221 to 4095. The higher the value loaded in this register, the higher the resulting clock frequency with respect to a fixed HSYNC frequency.

VESA has established some standard timing specifications, which assists in determining the value for PLLDIV as a function of horizontal and vertical display resolution and frame rate (see Table 9).

However, many computer systems do not conform precisely to the recommendations, and these numbers should be used only as a guide. The display system manufacturer should provide automatic or manual means for optimizing PLLDIV. An incorrectly set PLLDIV usually produces one or more vertical noise bars on the display. The greater the error, the greater the number of bars produced.

The power-up default value of PLLDIV is 1693 (PLLDIVM = 0x69, PLLDIVL = 0xDx).

The AD9396 updates the full divide ratio only when the LSBs are changed. Writing to this register by itself does not trigger an update.

0x02—Bits[7:4] PLL Divide Ratio LSBs

The four least significant bits of the 12-bit PLL divide ratio PLLDIV.

The power-up default value of PLLDIV is 1693 (PLLDIVM = 0x69, PLLDIVL = 0xDx).

CLOCK GENERATOR CONTROL

0x03—Bits[7:6] VCO Range Select

Two bits that establish the operating range of the clock generator. VCORNGE must be set to correspond with the desired operating frequency (incoming pixel rate). The PLL gives the best jitter performance at high frequencies. For this reason, to output low pixel rates and still get good jitter performance, the PLL actually operates at a higher frequency but then divides down the clock rate. Table 13 shows the pixel rates for each VCO range setting. The PLL output divisor is automatically selected with the VCO range setting.

Table 13. VCO Ranges

VCO Range	Pixel Rate Range
00	12 to 30
01	30 to 60
10	60 to 120
11	120 to 150

The power-up default value is 01.

Bits[5:3] Charge Pump Current

Three bits that establish the current driving the loop filter in the clock generator.

Table 14. Charge Pump Currents

Ip2	Ip1	Ip0	Current (µA)
0	0	0	50
0	0	1	100
0	1	0	150
0	1	1	250
1	0	0	350
1	0	1	500
1	1	0	750
1	1	1	1500

The power-up default value is current = 001.

Bit[2] External Clock Enable

This bit determines the source of the pixel clock.

A Logic 0 enables the internal PLL that generates the pixel clock from an externally provided HSYNC.

A Logic 1 enables the external CKEXT input pin. In this mode, the PLL divide ratio (PLLDIV) is ignored. The clock phase adjusts (phase is still functional). The power-up default value is EXTCLK = 0.

0x04—Bits[7:3] Phase Adjust

These bits provide a phase adjustment for the DLL to generate the ADC clock, a 5-bit value that adjusts the sampling phase in 32 steps across one pixel time. Each step represents an 11.25° shift in sampling phase. The power-up default is 16.

INPUT GAIN

0x05—Bits[7:0] Red Channel Gain

These bits control the programmable gain amplifier (PGA) of the red channel. The AD9396 can accommodate input signals with a full-scale range of between 0.5 V p-p and 1.0 V p-p. Setting the red gain to 255 corresponds to an input range of 1.0 V. A red gain of 0 establishes an input range of 0.5 V. Note that increasing red gain results in the picture having less contrast (the input signal uses fewer of the available converter codes). The power-up default is 0x80.

0x06—Bits[7:0] Green Channel Gain

These bits control the PGA of the green channel. The AD9396 can accommodate input signals with a full-scale range of between 0.5 V p-p and 1.0 V p-p. Setting the green gain to 255 corresponds to an input range of 1.0 V. A green gain of 0 establishes an input range of 0.5 V. Note that increasing green gain results in the picture having less contrast (the input signal uses fewer of the available converter codes). The power-up default is 0x80.

0x07—Bits[7:0] Blue Channel Gain

These bits control the PGA of the blue channel. The AD9396 can accommodate input signals with a full-scale range of between 0.5 V and 1.0 V p-p. Setting the blue gain to 255 corresponds to an input range of 1.0 V. A blue gain of 0 establishes an input range of 0.5 V. Note that increasing blue gain results in the picture having less contrast (the input signal uses fewer of the available converter codes). The power-up default is 0x80.

INPUT OFFSET

0x08—Bits[7:0] Red Channel Offset Adjust

If clamp feedback is enabled, the 8-bit offset adjust determines the clamp code. The 8-bit offset adjust is a twos complement number consisting of 1 sign bit plus 7 bits (0x7F = +127, 0x00 = 0, 0xFF = -1, and 0x80 = -128). For example, if the register is programmed to 130d, then the output code is equal to 130d at the end of the clamp period. Note that incrementing the offset register setting by 1 LSB adds 1 LSB of offset, regardless of the clamp feedback setting. The power-up default is 0.

0x09—Bits[7:0] Red Channel Offset

These eight bits are the red channel offset control. The offset control shifts the analog input, resulting in a change in brightness. Note that the function of the offset register depends on whether clamp feedback is enabled (Register 0x1C, Bit 7 = 1).

If clamp feedback is disabled, the offset register bits control the absolute offset added to the channel. The offset control provides +127/-128 LSBs of adjustment range, with 1 LSB of offset corresponding to 1 LSB of output code. If clamp feedback is enabled these bits provide the relative offset (brightness) from the offset adjust in the previous register. The power-up default is 0x80.

0x0A—Bits[7:0] Green Channel Offset Adjust

If clamp feedback is enabled, the 8-bit offset adjust determines the clamp code. The 8-bit offset adjust is a twos complement number consisting of 1 sign bit plus 7 bits (0x7F = +127, 0x00 = 0, 0xFF = -1, and 0x80 = -128). For example, if the register is programmed to 130d, then the output code is equal to 130d at the end of the clamp period. Note that incrementing the offset register setting by 1 LSB adds 1 LSB of offset, regardless of the clamp feedback setting. The power-up default is 0.

0x0B—Bits[7:0] Green Channel Offset

These eight bits are the green channel offset control. The offset control shifts the analog input, resulting in a change in brightness. Note that the function of the offset register depends on whether clamp feedback is enabled (Register 0x1C, Bit 7 = 1).

If clamp feedback is disabled, the offset register bits control the absolute offset added to the channel. The offset control provides an adjustment range of +127/-128 LSBs, with one LSB of offset corresponding to 1 LSB of output code. If clamp feedback is enabled, these bits provide the relative offset (brightness) from the offset adjust in the previous register. The power-up default is 0x80.

0x0C—Bits[7:0] Blue Channel Offset Adjust

If clamp feedback is enabled, the 8-bit offset adjust determines the clamp code. The 8-bit offset adjust is a twos complement number consisting of 1 sign bit plus 7 bits (0x7F = +127, 0x00 = 0, 0xFF = -1, and 0x80 = -128). For example, if the register is programmed to 130d, then the output code is equal to 130d at the end of the clamp period. Note that incrementing the offset register setting by 1 LSB adds 1 LSB of offset, regardless of the clamp feedback setting. The power-up default is 0.

0x0D—Bits[7:0] Blue Channel Offset

These eight bits are the blue channel offset control. The offset control shifts the analog input, resulting in a change in brightness. Note that the function of the offset register depends on whether clamp feedback is enabled (Register 0x1C, Bit 7 = 1).

If clamp feedback is disabled, the offset register bits control the absolute offset added to the channel. The offset control provides an adjustment range of +127/-128 LSBs, with 1 LSB of offset corresponding to 1 LSB of output code. If clamp feedback is enabled, these bits provide the relative offset (brightness) from the offset adjust in the previous register. The power-up default is 0x80.

SYNC

0x0E—Bits[7:0] Sync Separator

Selects the maximum HSYNC pulse width for composite sync separation. Power-down default is 0x20.

0x0F—Bits[7:2] SOG Comparator Threshold Enter

The enter level for the SOG slicer. Must be < the exit level (Register 0x10). The power-up default is 0x10.

0x10—Bits[7:2] SOG Comparator Threshold Exit

The exit level for the SOG slicer. Must be > the enter level (Register 0x0F). The power-up default is 0x10.

0x11—Bit[7] HSYNC Source

0 = HSYNC, 1 = SOG. The power-up default is 0. These selections are ignored if Register 0x11, Bit 6 = 0.

0x11—Bit[6] HSYNC Source Override

0 = auto HSYNC source, 1 = manual HSYNC source. Manual HSYNC source is defined in Register 0x11, Bit 7. The power-up default is 0.

0x11—Bit[5] VSYNC Source

0 = VSYNC, 1 = VSYNC from SOG. The power-up default is 0. These selections are ignored if Register 0x11, Bit 4 = 0.

0x11—Bit[4] VSYNC Source Override

0 = auto VSYNC source, 1 = manual VSYNC source. Manual VSYNC source is defined in Register 0x11, Bit 5. The power-up default is 0.

0x11—Bit[3] Channel Select

0 = Channel 0, 1 = Channel 1. The power-up default is 0. These selections are ignored if Register 0x11, Bit 2 = 0.

0x11—Bit[2] Channel Select Override

0 = auto channel select, 1 = manual channel select. Manual channel select is defined in Register 0x11, Bit 3. The power-up default is 0.

0x11—Bit[1] Interface Select

0 = analog interface, 1 = digital interface. The power-up default is 0. These selections are ignored if Register 0x11, Bit 0 = 0.

0x11—Bit[0] Interface Select Override

0 = auto interface select, 1 = manual interface select. Manual interface select is defined in Register 0x11, Bit 1. The power-up default is 0.

0x12—Bit[7] Input HSYNC Polarity

0 = active low, 1 = active high. The power-up default is 1. These selections are ignored if Register 10x2, Bit 6 = 0.

0x12—Bit[6] HSYNC Polarity Override

0 = auto HSYNC polarity, 1 = manual HSYNC polarity. Manual HSYNC polarity is defined in Register 0x11, Bit 7. The power-up default is 0.

0x12—Bit[5] Input VSYNC Polarity

0 = active low, 1 = active high. The power-up default is 1. These selections are ignored if Register 0x11, Bit 4 = 0.

0x12—Bit[4] VSYNC Polarity Override

0 = auto VSYNC polarity, 1 = manual VSYNC polarity. Manual VSYNC polarity is defined in Register 0x11, Bit 5. The power-up default is 0.

COAST AND CLAMP CONTROLS**0x12—Bit[3] Input Coast Polarity**

0 = active low, 1 = active high. The power-up default is 1.

0x12—Bit[2] Coast Polarity Override

0 = auto-coast polarity, 1 = manual coast polarity. The power-up default is 0.

0x12—Bit[1] Coast Source

0 = internal coast, 1 = external coast. The power-up default is 0.

0x12—Bit[0] Filter Coast VSYNC

0 = use raw VSYNC for coast generation, 1 = use filtered VSYNC for coast generation. The power-up default is 1.

0x13—Bits[7:0] Precoast

This register allows the internally generated coast signal to be applied prior to the VSYNC signal. This is necessary in cases where pre-equalization pulses are present. The step size for this control is one HSYNC period. For precoast to work correctly, it is necessary for the VSYNC filter (0x21, Bit 5) and sync processing filter (0x21 Bit 7) both to be either enabled or disabled. The power-up default is 0.

0x14—Bits[7:0] Postcoast

This register allows the internally generated coast signal to be applied following the VSYNC signal. This is necessary in cases where postequalization pulses are present. The step size for this control is one HSYNC period. For postcoast to work correctly, it is necessary for the VSYNC filter (0x21, Bit 5) and sync processing filter (0x21, Bit 7) both to be either enabled or disabled. The power-up default is 0.

STATUS OF DETECTED SIGNALS**0x15—Bit[7] HSYNC0 Detection Bit**

Indicates if HSYNC0 is active. This bit is used to indicate when activity is detected on the HSYNC0 input pin. If HSYNC is held high or low, activity is not detected. The sync processing block diagram shows where this function is implemented. 0 = HSYNC0 not active. 1 = HSYNC0 is active.

0x15—Bit[6] HSYNC1 Detection Bit

Indicates if HSYNC1 is active. This bit is used to indicate when activity is detected on the HSYNC1 input pin. If HSYNC is held high or low, activity is not detected. The sync processing block diagram shows where this function is implemented. 0 = HSYNC1 not active. 1 = HSYNC1 is active.

0x15—Bit[5] VSYNC0 Detection Bit

Indicates if VSYNC0 is active. This bit is used to indicate when activity is detected on the VSYNC0 input pin. If VSYNC is held high or low, activity is not detected. The sync processing block diagram shows where this function is implemented. 0 = VSYNC0 not active. 1 = VSYNC0 is active.

0x15—Bit[4] VSYNC1 Detection Bit

Indicates if VSYNC1 is active. This bit is used to indicate when activity is detected on the VSYNC1 input pin. If VSYNC is held high or low, activity is not detected. The sync processing block diagram shows where this function is implemented. 0 = VSYNC1 not active. 1 = VSYNC1 is active.

0x15—Bit[3] SOG0 Detection Bit

Indicates if SOG0 is active. This bit is used to indicate when activity is detected on the SOG0 input pin. If SOG is held high or low, activity is not detected. The sync processing block diagram shows where this function is implemented. 0 = SOG0 not active. 1 = SOG0 is active.

0x15—Bit[2] SOG1 Detection Bit

Indicates if SOG1 is active. This bit is used to indicate when activity is detected on the SOG1 input pin. If SOG is held high or low, activity is not detected. The sync processing block diagram shows where this function is implemented. 0 = SOG1 not active. 1 = SOG1 is active.

0x15—Bit[1] Coast Detection Bit

This bit detects activity on the EXTCLK/EXTCOAST pin. It indicates that one of the two signals is active, but it doesn't indicate if it is EXTCLK or COAST. A dc signal is not detected. 0 = no activity detected. 1 = activity detected.

POLARITY STATUS**0x16—Bit[7] HSYNC 0 Polarity**

Indicates the polarity of the HSYNC0 input. 0 = HSYNC polarity negative. 1 = HSYNC polarity positive.

0x16—Bit[6] HSYNC 1 Polarity

Indicates the polarity of the HSYNC1 input. 0 = HSYNC polarity negative. 1 = HSYNC polarity positive.

0x16—Bit[5] VSYNC 0 Polarity

Indicates the polarity of the VSYNC0 input. 0 = VSYNC polarity negative. 1 = VSYNC polarity positive.

0x16—Bit[4] VSYNC1 Polarity

Indicates the polarity of the VSYNC1 input. 0 = VSYNC polarity negative. 1 = VSYNC polarity positive.

0x16—Bit[3] Coast Polarity

Indicates the polarity of the external coast signal. 0 = coast polarity negative. 1 = coast polarity positive.

0x16—Bit[2] Pseudo Sync Detected**0x16—Bit[1] Sync Filter Locked**

Indicates whether sync filter is locked to periodic sync signals. 0 = sync filter locked to periodic sync signal. 1 = sync filter not locked.

0x16—Bit[0] Bad Sync Detect**0x17—Bits[3:0] HSYNCs per VSYNC MSBs**

The 4 MSBs of the 12-bit counter that reports the number of HSYNCs/VSYNC on the active input. This is useful in determining the mode and aids in setting the PLL divide ratio.

0x18—Bits[7:0] HSYNCs per VSYNC LSBs

The 8 LSBs of the 12-bit counter that reports the number of HSYNCs/VSYNC on the active input.

0x19—Bits[7:0] Clamp Placement

Number of pixel clocks after the trailing edge of HSYNC to begin clamp. The power-up default is 8.

0x1A—Bits[7:0] Clamp Duration

Number of pixel clocks to clamp. The power-up default is 0x14.

0x1B—Bits[7] Red Clamp Select

This bit selects whether the red channel is clamped to ground or midscale. Ground clamping is used for red in RGB applications and midscale clamping is used in YPrPb (YUV) applications. 0 = channel clamped to ground during clamping period. 1 = channel clamped to midscale during clamping period. The power-up default is 0.

0x1B—Bit[6] Green Clamp Select

This bit selects whether the green channel is clamped to ground or midscale. Ground clamping is normally used for green in RGB applications and YPrPb (YUV) applications. 0 = channel clamped to ground during clamping period. 1 = channel clamped to midscale during clamping period. The power-up default is 0.

0x1B—Bit[5] Blue Clamp Select

This bit selects whether the blue channel is clamped to ground or midscale. Ground clamping is used for blue in RGB applications and midscale clamping is used in YPrPb (YUV) applications. 0 = channel clamped to ground during clamping period. 1 = channel clamped to midscale during clamping period. The power-up default is 0.

0x1B—Bit[4] Clamp During Coast

This bit permits clamping to be disabled during coast because video signals are generally not at a known back porch or midscale position during coast. 0 = clamping during coast is disabled. Clamping during coast is enabled. The power-up default is 0.

0x1B—Bit[3] Clamp Disable

0 = internal clamp enabled. 1 = internal clamp disabled. The power-up default is 0.

0x1B—Bits[2:1] Programmable Bandwidth

x0 = low bandwidth. x1 = high bandwidth. The power-up default is 1.

0x1B—Bit[0] Hold Auto-Offset

0 = normal auto-offset operation. 1 = hold current offset value. The power-up default is 0.

0x1C—Bit[7] Auto-Offset Enable

0 = manual offset. 1 = auto-offset using offset as target code. The power-up default is 0.

0x1C—Bits[6:5] Auto-Offset Update Mode

00 = every clamp.
01 = every 16 clamps.
10 = every 64 clamps.
11 = every VSYNC.

The power-up default setting is 10.

0x1C—Bits[4:3] Difference Shift Amount

00 = 100% of difference used to calculate new offset.
01 = 50%.
10 = 25%.
11 = 12.5%.

The power-up default is 01.

0x1C—Bit[2] Auto-Jump Enable

0 = normal operation. 1 = if the code >15 codes off, the offset is jumped to the predicted offset necessary to fix the >15 code mismatch. The power-up default is 1.

0x1C—Bit[1] Post Filter Enable

The post filter reduces the update rate by 1/6 and requires that all six updates recommend a change before changing the offset. This prevents unwanted offset changes. 0 = disable post filter. 1 = enable post filter. The power-up default is 1.

0x1C—Bit[0] Toggle Filter Enable

The toggle filter looks for the offset to toggle back and forth and holds it if triggered. This is to prevent toggling in case of missing codes in the PGA. 1 = toggle filter on. 0 = toggle filter off. The power-up default is 0.

0x1D—Bits[7:0] Slew Limit

Limits the amount the offset can change in a single update. The power-up default is 0x08.

0x1E—Bits[7:0] Sync Filter Lock Threshold

This 8-bit register is programmed to set the number of valid HSYNCs needed to lock the sync filter. This ensures that a consistent, stable HSYNC is present before attempting to filter. The power-up default setting is 32d.

0x1F—Bits[7:0] Sync Filter Unlock Threshold

This 8-bit register is programmed to set the number of missing or invalid HSYNCs needed to unlock the sync filter. This disables the filter operation when there is no longer a stable HSYNC signal. The power-up default setting is 50d.

0x20—Bits[7:0] Sync Filter Window Width

This 8-bit register sets the distance in 40 MHz clock periods (25 ns), which is the allowed distance for HSYNC pulses before and after the expected HSYNC edge. This is the heart of the filter in that it only looks for HSYNC pulses at a given time (plus or minus this window) and then ignores extraneous equalization pulses that disrupt accurate PLL operation. The power-up default setting is 10d, or 200 ns on either side of the expected HSYNC.

0x21—Bit[7] Sync Processing Filter Enable

This bit selects which HSYNC is used for the sync processing functions of internal coast, H/V count, field detection, and VSYNC duration counts. A clean HSYNC is fundamental to accurate processing of the sync. 0 = sync processing uses raw HSYNC or SOG. 1 = sync processing uses regenerated HSYNC from sync filter. The power-up default setting is 1.

0x21—Bit[6] PLL Sync Filter Enable

This bit selects which signal the PLL uses. It can select between raw HSYNC or SOG, or filtered versions. The filtering of the HSYNC and SOG can eliminate nearly all extraneous transitions which have traditionally caused PLL disruption. 0 = PLL uses raw HSYNC or SOG inputs. 1 = PLL uses filtered HSYNC or SOG inputs. The power-up default setting is 0.

0x21—Bit[5] VSYNC Filter Enable

The purpose of the VSYNC filter is to guarantee the position of the VSYNC edge with respect to the HSYNC edge and to generate a field signal. The filter works by examining the placement of VSYNC and regenerating a correctly placed VSYNC one line later. The VSYNC is first checked to see whether it occurs in the Field 0 position or the Field 1 position. This is done by checking the leading edge position against the sync separator threshold and the HSYNC position. The HSYNC width is divided into four quadrants with Quadrant 1 starting at the HSYNC leading edge plus a sync separator threshold. If the VSYNC leading edge occurs in Quadrant 1 or Quadrant 4, the field is set to 0 and the output VSYNC is placed coincident with the HSYNC leading edge. If the VSYNC leading edge occurs in Quadrant 2 or Quadrant 3, the field is set to 1 and the output VSYNC leading edge is placed in the center of the line. In this way, the VSYNC filter creates a predictable relative position between HSYNC and VSYNC edges at the output.

If the VSYNC occurs near the HSYNC edge, this guarantees that the VSYNC edge follows the HSYNC edge. This performs filtering also in that it requires a minimum of 64 lines between VSYNCS. The VSYNC filter cleans up extraneous pulses that might occur on the VSYNC. This should be enabled whenever the HSYNC/VSYNC count is used. Setting this bit to 0 disables the VSYNC filter. Setting this bit to 1 enables the VSYNC filter. Power-up default is 0.

0x21—Bit[4] VSYNC Duration Enable

This enables the VSYNC duration block which is designed to be used with the VSYNC filter. Setting the bit to 0 leaves the VSYNC output duration unchanged; setting the bit to 1 sets the VSYNC output duration based on Register 0x22. 0 = VSYNC output duration unchanged. 1 = VSYNC output duration set by 0x22. The power-up default is 0.

0x21—Bit[3] Auto-Offset Clamp Mode

This bit specifies if the auto-offset measurement takes place during clamp or 10 or 16 clocks afterward. The measurement takes 6 clock cycles. 0 = auto-offset measurement takes place during clamp period. 1 = auto-offset measurement is set by 0x21, Bit 2. Default= 1.

0x21—Bit[2] Auto-Offset Clamp Length

This bit sets the delay following the end of the clamp period for AO measurement. This bit is valid only if Register 0x21, Bit 3 = 1. 0 = delay is 10 clock cycles. 1 = delay is 16 clock cycles. Default = 1.

0x22—Bits[7:0] VSYNC Duration

This is used to set the output duration of the VSYNC, and is designed to be used with the VSYNC filter. This is valid only if Register 0x21, Bit 4 is set to 1. Power-up default is 4.

0x23—Bits[7:0] HSYNC Duration

An 8-bit register that sets the duration of the HSYNC output pulse. The leading edge of the HSYNC output is triggered by the internally generated, phase-adjusted PLL feedback clock. The AD9396 then counts a number of pixel clocks equal to the value in this register. This triggers the trailing edge of the HSYNC output, which is also phase-adjusted. The power-up default is 32.

0x24—Bit[7] HSYNC Output Polarity

This bit sets the polarity of the HSYNC output. Setting this bit to 0 sets the HSYNC output to active low. Setting this bit to 1 sets the HSYNC output to active high. Power-up default setting is 1.

0x24—Bit[6] VSYNC Output Polarity

This bit sets the polarity of the VSYNC output (both DVI and analog). Setting this bit to 0 sets the VSYNC output to active low. Setting this bit to 1 sets the VSYNC output to active high. Power-up default is 1.

0x24—Bit[5] Display Enable Output Polarity

This bit sets the polarity of the display enable (DE) for both DVI and analog. 0 = DE output polarity is negative. 1 = DE output polarity is positive. The power-up default is 1.

0x24—Bit[4] Field Output Polarity

This bit sets the polarity of the field output signal (both DVI and analog) on Pin 21. 0 = active low out. 1 = active high out. The power-up default is 1.

0x24—Bit[3] SOG Output Polarity

This bit sets the polarity of the SOGOUT signal (analog only). 0 = active low. 1 = active high. The power-up default setting is 1.

0x24—Bits[2:1] SOG Output Select

These register bits control the output on the SOGOUT pin. Options are the raw SOG from the slicer (this is the unprocessed SOG signal produced from the sync slicer), the raw HSYNC, the regenerated sync from the sync filter, which can generate missing syncs because of coasting, dropout, or the filtered sync that excludes extraneous syncs not occurring within the sync filter window.

Table 15. SOGOUT Polarity Settings

SOGOUT Select	Function
00	Raw SOG from sync slicer (SOG0 or SOG1)
01	Raw HSYNC (HSYNC0 or HSYNC1)
10	Regenerated sync from sync filter
11	HSYNC to PLL

The power-up default setting is 11.

0x24—Bit[0] Output Clock Invert

This bit allows inversion of the output clock as specified by Register 0x25, Bit 7 to Bit 6. 0 = noninverted clock. 1 = inverted clock. The power-up default setting is 0.

0x25—Bits[7:6] Output Clock Select

These bits select the clock output on the DATACLK pin. They include 1/2× clock, a 2× clock, a 90° phase shifted clock or the normal pixel clock. The power-up default setting is 01.

Table 16. Output Clock Select

Select	Result
00	1/2× pixel clock
01	1× pixel clock
10	2× pixel clock
11	90° phase 1× pixel clock

0x25—Bits[5:4] Output Drive Strength

These two bits select the drive strength for all the high speed digital outputs (except VSOUT, A0, and the O/E Field). Higher drive strength results in faster rise times/fall times and makes it easier to capture data. Lower drive strength results in slower rise/fall times and helps to reduce EMI and digitally generated power supply noise. The power-up default setting is 11.

Table 17. Output Drive Strength

Output Drive	Result
00	Low output drive strength
01	Medium low output drive strength
10	Medium high output drive strength
11	High output drive strength

0x25—Bits[3:2] Output Mode

These bits choose between four options for the output mode, one of which is exclusive to an HDMI input. 4:4:4 mode is standard RGB; 4:2:2 mode is YCrCb, which reduces the number of active output pins from 24 to 16; 4:4:4 is the double data rate (DDR) output mode; and the data is RGB mode, but changes on every clock edge. The power-up default setting is 00.

Table 18. Output Mode

Output Mode	Result
00	4:4:4 RGB mode
01	4:2:2 YCrCb mode + DDR 4:2:2 on blue (secondary)
10	DDR 4:4:4: DDR mode + DDR 4:2:2 on blue (secondary)

0x25—Bit[1] Primary Output Enable

This bit places the primary output in active or high impedance mode. The primary output is designated when using either 4:2:2 or DDR 4:4:4. In these modes, the data on the red and green output channels is the primary output, while the output data on the blue channel (DDR YCrCb) is the secondary output. 0 = primary output is in high impedance mode. 1 = primary output is enabled. The power-up default setting is 1.

0x25—Bit[0] Secondary Output Enable

This bit places the secondary output in active or high impedance mode. The secondary output is designated when using either 4:2:2 or DDR 4:4:4. In these modes the data on the blue output channel is the secondary output, while the output data on the red and green channels is the primary output. Secondary output is always a DDR YCrCb data mode. 0 = secondary output is in high impedance mode. 1 = secondary output is enabled. The power-up default setting is 0.

0x26—Bit[7] Output Three-State

When enabled, this bit puts all outputs (except SOGOUT) in a high impedance state. 0 = normal outputs. 1 = all outputs (except SOGOUT) in high impedance mode. The power-up default setting is 0.

0x26—Bit[6] SOG Three-State

When enabled, this bit allows the SOGOUT pin to be placed in a high impedance state. 0 = normal SOG output. 1 = SOGOUT pin is in high impedance mode. The power-up default setting is 0.

0x26—Bit[3] Power-Down Polarity

This bit defines the polarity of the input power-down pin. 0 = power-down pin is active low. 1 = power-down pin is active high. The power-up default setting is 1.

0x26—Bits[2:1] Power-Down Pin Function

These bits define the different operational modes of the power-down pin. These bits are functional only when the power-down pin is active; when it is not active, the part is powered up and functioning. The power-up default setting is 00.

Table 19. Power Down Pin Function

Function	Result
00	The chip is powered down and all outputs except SOGOUT are in high impedance mode.
01	The chip is powered down and all outputs are in high impedance mode.
10	The chip remains powered up, but all outputs except SOGOUT are in high impedance mode.
11	The chip remains powered up, but all outputs are in high impedance mode.

0x26—Bit[0] Power-Down

This bit is used to put the chip in power-down mode. In this mode, the power dissipation is reduced to a fraction of the typical power (see Table 1 for exact power dissipation). When in power-down, the HSOUT, VSOUT, DATAACK, and all 30 data outputs are put into a high impedance state. Note that the SOGOUT output is not put into high impedance. Circuit blocks that continue to be active during power-down include the voltage references, sync processing, sync detection, and the serial register. These blocks facilitate a fast start-up from power-down. 0 = normal operation. 1 = power-down. The power-up default setting is 0.

0x27—Bit[7] Auto Power-Down Enable

This bit enables the chip to go into low power mode, or seek mode if no sync inputs are detected. 0 = auto power-down disabled. 1 = chip powers down if no sync inputs present. The power-up default setting is 1.

0x27—Bit[6] HDCP A0 Address

This bit sets the LSB of the address of the HDCP I²C. This should be set to 1 only for a second receiver in a dual-link configuration. The power-up default is 0.

BT656 GENERATION**0x27—Bit[4] BT656 Enable**

This bit enables the output to be BT656-compatible with defined start of active video (SAV) and end of active video (EAV) controls to be inserted. These require specification of the number of active lines, active pixels per line, and delays to place these markers. 0 = disable BT656 video mode. 1 = enable BT656 video mode. The power-up default setting is 0.

0x27—Bit[3] Force DE Generation

This bit allows the use of the internal DE generator in DVI mode. 0 = internal DE generation disabled. 1 = force DE generation via programmed registers. The power-up default setting is 0.

0x27—Bits[2:0] Interlace Offset

These bits define the offset in HSYNCs from Field 0 to Field 1. The power-up default setting is 000.

0x28—Bits[7:2] VSYNC Delay

These bits set the delay (in lines) from the leading edge of VSYNC to active video. The power-up default setting is 24.

0x28—Bits[1:0] HSYNC Delay MSBs

These 2 bits along with the following 8 bits set the delay (in pixels) from the HSYNC leading edge to the start of active video. The power-up default setting is 0x104.

0x29—Bits[7:0] HSYNC Delay LSBs

See the HSYNC Delay MSBs section.

0x2A—Bits[3:0] Line Width MSBs

These 4 bits along with the following 8 bits set the width of the active video line (in pixels). The power-up default setting is 0x500.

0x2B—Bits[7:0] Line Width LSBs

See the line width MSBs section.

0x2C—Bits[3:0] Screen Height MSBs

Along with the 8 bits following these 12 bits, set the height of the active screen (in lines). The power-up default setting is 0x2D0.

0x2D—Bits[7:0] Screen Height LSBs

See the Screen Height MSBs section.

0x2F—Bit[6] TMDS Sync Detect

This read-only bit indicates the presence of a TMDS DE. 0 = no TMDS DE present. 1 = TMDS DE detected.

0x2F—Bit[5] TMDS Active

This read-only bit indicates the presence of a TMDS clock. 0 = no TMDS clock present. 1 = TMDS clock detected.

0x2F—Bit[4] AV Mute

This read-only bit indicates the presence of AV mute based on general control packets. 0 = AV not muted. 1 = AV muted.

0x2F—Bit[3] HDCP Keys Read

This read-only bit reports if the HDCP keys were read successfully. 0 = failure to read HDCP keys. 1 = HDCP keys read.

0x2F—Bits[2:0] DVI Quality

These read-only bits indicate a level of DVI quality based on the DE (display enable) edges. A larger number indicates a higher quality.

0x30—Bit[5] DVI HSYNC Polarity

This read-only bit indicates the polarity of the DVI HSYNC. 0 = DVI HSYNC polarity is low active. 1 = DVI HSYNC polarity is high active

0x30—Bit[4] DVI VSYNC Polarity

This read-only bit indicates the polarity of the DVI VSYNC. 0 = DVI VSYNC polarity is low active. 1 = DVI VSYNC polarity is high active.

MACROVISION**0x31—Bits[7:4] Macrovision Pulse Max**

These bits set the pseudo sync pulse width maximum for Macrovision detection in pixel clocks. This is functional for 13.5 MHz SDTV or 27 MHz progressive scan. Power-up default is 9.

0x31—Bits[3:0] Macrovision Pulse Min

These bits set the pseudo sync pulse width maximum for Macrovision detection in pixel clocks. This is functional for 13.5 MHz SDTV or 27 MHz progressive scan. Power-up default is 6.

0x32—Bit[7] Macrovision Oversample Enable

Tells the Macrovision detection engine whether oversampling is used. This accommodates 27 MHz sampling for SDTV and 54 MHz sampling for progressive scan and is used as a correction factor for clock counts. Power-up default is 0.

0x32—Bit[6] Macrovision PAL Enable

Tells the Macrovision detection engine to enter PAL mode when set to 1. Default is 0 for NTSC mode.

0x32—Bits[5:0] Macrovision Line Count Start

Set the start line for Macrovision detection. Along with Register 0x33, Bits [5:0] they define the region where MV pulses are expected to occur. The power-up default is Line 13.

0x33—Bit[7] Macrovision Detect Mode

0 = standard definition. 1 = progressive scan mode

0x33—Bit[6] Macrovision Settings Override

This defines whether preset values are used for the MV line counts and pulse widths or the values stored in I²C registers.
 0 = use hard-coded settings for line counts and pulse widths
 1 = use I²C values for these settings

0x33—Bits[5:0] Macrovision Line Count End

Set the end line for Macrovision detection. Along with Register 0x32, Bits [5:0] they define the region where MV pulses are expected to occur. The power-up default is Line 21.

0x34—Bits[7:6] Macrovision Pulse Limit Select

Set the number of pulses required in the last three lines (SD mode only). If there is not at least this number of MV pulses, the engine stops. These 2 bits define the following pulse counts:

- 00 = 6
- 01 = 4
- 10 = 5 (default)
- 11 = 7

0x34—Bit[5] Low Frequency Mode

Sets whether the audio PLL is in low frequency mode. Low frequency mode should only be set for pixel clocks < 80 MHz.

0x34—Bit[4] Low Frequency Override

Allows the previous bit to be used to set low frequency mode rather than the internal autodetect.

0x34—Bit[3] Up Conversion Mode

- 0 = repeat Cb/Cr values
- 1 = interpolate Cb/Cr values

0x34—Bit[2] CbCr Filter Enable

Enables the FIR filter for 4:2:2 CbCr output.

COLOR SPACE CONVERSION

The default power up values for the color space converter coefficients (R0x35 through R0x4C) are set for ATSC RGB to YCbCr conversion. They are completely programmable for other conversions.

0x34—Bit[1] Color Space Converter Enable

This bit enables the color space converter. 0 = disable color space converter. 1 = enable color space converter. The power-up default setting is 0.

0x35—Bits[6:5] Color Space Converter Mode

These two bits set the fixed point position of the CSC coefficients, including the A4, B4, and C4 offsets. Default = 01.

Table 20. CSC Fixed Point Converter Mode

Select	Result
00	±1.0, -4096 to +4095
01	±2.0, -8192 to +8190
1x	±4.0, -16384 to +16380

0x35—Bits[4:0] Color Space Conversion Coefficient A1 MSBs

These 5 bits form the 5 MSBs of the Color space Conversion Coefficient A1. This combined with the 8 LSBs of the following register form a 13-bit, twos complement coefficient which is user programmable. The equation takes the form of:

$$\begin{aligned} R_{OUT} &= (A1 \times R_{IN}) + (A2 \times G_{IN}) + (A3 \times B_{IN}) + A4 \\ G_{OUT} &= (B1 \times R_{IN}) + (B2 \times G_{IN}) + (B3 \times B_{IN}) + B4 \\ B_{OUT} &= (C1 \times R_{IN}) + (C2 \times G_{IN}) + (C3 \times B_{IN}) + C4 \end{aligned}$$

The default value for the 13-bit, A1 coefficient is 0x0C52.

0x36—Bits[7:0] Color Space Conversion Coefficient A1 LSBs

See the Register 0x35 section.

0x37—Bits[4:0] CSC A2 MSBs

These five bits form the 5 MSBs of the Color space Conversion Coefficient A2. Combined with the 8 LSBs of the following register, they form a 13-bit, twos complement coefficient that is user programmable. The equation takes the form of:

$$\begin{aligned} R_{OUT} &= (A1 \times R_{IN}) + (A2 \times G_{IN}) + (A3 \times B_{IN}) + A4 \\ G_{OUT} &= (B1 \times R_{IN}) + (B2 \times G_{IN}) + (B3 \times B_{IN}) + B4 \\ B_{OUT} &= (C1 \times R_{IN}) + (C2 \times G_{IN}) + (C3 \times B_{IN}) + C4 \end{aligned}$$

The default value for the 13-bit A2 coefficient is 0x0800.

0x38—Bits[7:0] CSC A2 LSBs

See the Register 0x37 section.

0x39—Bits[4:0] CSC A3 MSBs

The default value for the 13-bit A3 is 0x0000.

0x3A—Bits[7:0] CSC A3 LSBs**0x3B—Bits[4:0] CSC A4 MSBs**

The default value for the 13-bit A4 is 0x19D7.

0x3C—Bits[7:0] CSC A4 LSBs**0x3D—Bits[4:0] CSC B1 MSBs**

The default value for the 13-bit B1 is 0x1C54.

0x3E—Bits[7:0] CSC B1 LSBs**0x3F—Bits[4:0] CSC B2 MSB**

The default value for the 13-bit B2 is 0x0800.

0x40—Bits[7:0] CSC B2 LSBs**0x41—Bits[4:0] CSC B3 MSBs**

The default value for the 13-bit B3 is 0x1E89.

0x42—Bits[7:0] CSC B3 LSBs**0x43—Bits[4:0] CSC B4 MSBs**

The default value for the 13-bit B4 is 0x0291.

AD9396

0x44—Bits[7:0] CSC B4 LSBs**0x45—Bits[4:0] CSC C1 MSBs**

The default value for the 13-bit C1 is 0x0000.

0x46—Bits[7:0] CSC C1 LSBs**0x47—Bits[4:0] CSC C2 MSBs**

The default value for the 13-bit C2 is 0x0800.

0x48—Bits[7:0] CSC C2 LSBs**0x49—Bits[4:0] CSC C3 MSBs**

The default value for the 13-bit C3 is 0x0E87.

0x4A—Bits[7:0] CSC C3 LSBs**0x4B—Bits[4:0] CSC C4 MSBs**

The default value for the 13-bit C4 is 0x18BD.

0x4C—Bits[7:0] CSC C4 LSBs**0x59—Bit[6] MDA/MCL PU Disable**

This bit disables the inter MDA/MCL pull-ups.

0x59—Bit[5] CLK Term O/R

This bit allows for overriding during power down.

0 = auto, 1 = manual.

0x59—Bit[4] Manual CLK Term

This bit allows normal clock termination or disconnects it. 0 = normal, 1 = disconnected.

0x59—Bit[2] FIFO Reset UF

This bit resets the audio FIFO if underflow is detected.

0x59—Bit[1] FIFO Reset OF

This bit resets the audio FIFO if overflow is detected.

0x59—Bit[0] MDA/MCL Three-State

This bit three-states the MDA/MCL lines to allow in-circuit programming of the EEPROM.

2-WIRE SERIAL CONTROL PORT

A 2-wire serial interface control is provided in the AD9396. Up to two AD9396 devices can be connected to the 2-wire serial interface, with a unique address for each device.

The 2-wire serial interface comprises a clock (SCL) and a bidirectional data (SDA) pin. The analog flat panel interface acts as a slave for receiving and transmitting data over the serial interface. When the serial interface is not active, the logic levels on SCL and SDA are pulled high by external pull-up resistors.

Data received or transmitted on the SDA line must be stable for the duration of the positive-going SCL pulse. Data on SDA must change only when SCL is low. If SDA changes state while SCL is high, the serial interface interprets that action as a start or stop sequence.

There are six components to serial bus operation:

- Start signal
- Slave address byte
- Base register address byte
- Data byte to read or write
- Stop signal
- Acknowledge (Ack)

When the serial interface is inactive (SCL and SDA are high) communications are initiated by sending a start signal. The start signal is a high-to-low transition on SDA while SCL is high. This signal alerts all slave devices that a data transfer sequence is coming.

The first eight bits of data transferred after a start signal comprise a 7 bit slave address (the first 7 bits) and a single $\overline{R/W}$ bit (the 8th bit). The $\overline{R/W}$ bit indicates the direction of data transfer, read from (1) or write to (0) the slave device. If the transmitted slave address matches the address of the device (set by the state of the SA0 input pin, as shown in Table 21), the AD9396 acknowledges by bringing SDA low on the 9th SCL pulse. If the addresses do not match, the AD9396 does not acknowledge.

Table 21. Serial Port Addresses

Bit 7	Bit 6	Bit 5	Bit 4	Bit 3	Bit 2	Bit 1
A ₆ (MSB)	A ₅	A ₄	A ₃	A ₂	A ₁	A ₀
1	0	0	1	1	0	0

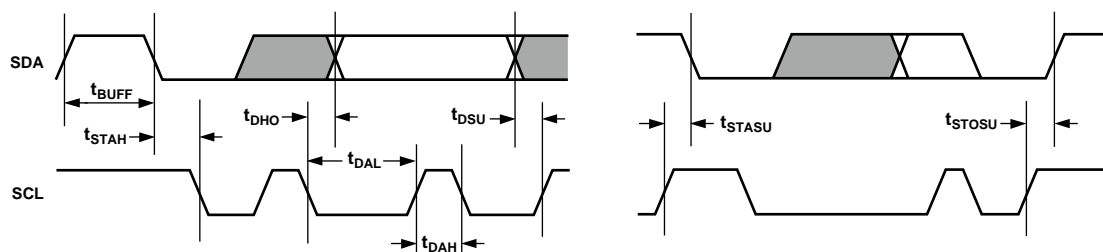

Figure 16. Serial Port Read/Write Timing

Data Transfer via Serial Interface

For each byte of data read or written, the MSB is the first bit of the sequence.

If the AD9396 does not acknowledge the master device during a write sequence, the SDA remains high so the master can generate a stop signal. If the master device does not acknowledge the AD9396 during a read sequence, the AD9396 interprets this as end of data. The SDA remains high, so the master can generate a stop signal.

Writing data to specific control registers of the AD9396 requires that the 8-bit address of the control register of interest be written after the slave address has been established. This control register address is the base address for subsequent write operations. The base address auto-increments by one for each byte of data written after the data byte intended for the base address. If more bytes are transferred than there are available addresses, the address does not increment and remains at its maximum value. Any base address higher than the maximum value does not produce an acknowledge signal.

Data are read from the control registers of the AD9396 in a similar manner. Reading requires two data transfer operations:

- The base address must be written with the $\overline{R/W}$ bit of the slave address byte low to set up a sequential read operation.
- Reading (the $\overline{R/W}$ bit of the slave address byte high) begins at the previously established base address. The address of the read register auto-increments after each byte is transferred.

To terminate a read/write sequence to the AD9396, a stop signal must be sent. A stop signal comprises a low-to-high transition of SDA while SCL is high.

A repeated start signal occurs when the master device driving the serial interface generates a start signal without first generating a stop signal to terminate the current communication. This is used to change the mode of communication (read, write) between the slave and master without releasing the serial interface lines.

Serial Interface Read/Write Examples

Write to one control register:

- Start signal
- Slave address byte ($\overline{R/\overline{W}}$ bit = low)
- Base address byte
- Data byte to base address
- Stop signal

Write to four consecutive control registers:

- Start signal
- Slave address byte ($\overline{R/\overline{W}}$ bit = low)
- Base address byte
- Data byte to base address
- Data byte to (base address + 1)
- Data byte to (base address + 2)
- Data byte to (base address + 3)
- Stop signal

Read from one control register:

- Start signal
- Slave address byte ($\overline{R/\overline{W}}$ bit = low)
- Base address byte
- Start signal
- Slave address byte ($\overline{R/\overline{W}}$ bit = high)
- Data byte from base address
- Stop signal

Read from four consecutive control registers:

- Start signal
- Slave address byte ($\overline{R/\overline{W}}$ bit = low)
- Base address byte
- Start signal
- Slave address byte ($\overline{R/\overline{W}}$ bit = high)
- Data byte from base address
- Data byte from (base address + 1)
- Data byte from (base address + 2)
- Data byte from (base address + 3)
- Stop signal

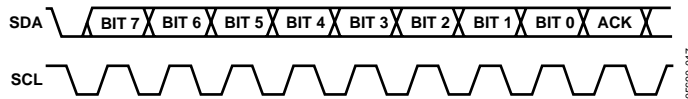

Figure 17. Serial Interface—Typical Byte Transfer

PCB LAYOUT RECOMMENDATIONS

The AD9396 is a high precision, high speed analog device. To achieve the maximum performance from the part, it is important to have a well laid-out board. The following is a guide for designing a board using the AD9396.

ANALOG INTERFACE INPUTS

Using the following layout techniques on the graphics inputs is extremely important:

- Minimize the trace length running into the graphics inputs by placing the AD9396 as close as possible to the graphics VGA connector. Long input trace lengths are undesirable, because they pick up more noise from the board and other external sources.
- Place the 75 Ω termination resistors (see Figure 3) as close to the AD9396 chip as possible. Any additional trace length between the termination resistors and the input of the AD9396 increases the magnitude of reflections, which corrupts the graphics signal.
- Use 75 Ω matched impedance traces. Trace impedances other than 75 Ω also increase the chance of reflections.

The AD9396 has very high input bandwidth (300 MHz). While this is desirable for acquiring a high resolution PC graphics signal with fast edges, it means that it also captures any high frequency noise present. Therefore, it is important to reduce the amount of noise that is coupled to the inputs. Avoid running any digital traces near the analog inputs.

Due to the high bandwidth of the AD9396, sometimes low-pass filtering the analog inputs can help to reduce noise. For many applications, filtering is unnecessary. Experiments have shown that placing a series ferrite bead prior to the 75 Ω termination resistor is helpful in filtering out excess noise. Specifically, the part used was the Fair-Rite 2508051217Z0, but each application may work best with a different bead value. Alternatively, placing a 100 Ω to 120 Ω resistor between the 75 Ω termination resistor and the input coupling capacitor can also be beneficial.

POWER SUPPLY BYPASSING

It is recommended to bypass each power supply pin with a 0.1 μF capacitor. The exception is when two or more supply pins are adjacent to each other. For these groupings of powers/grounds, it is only necessary to have one bypass capacitor. The fundamental idea is to have a bypass capacitor within about 0.5 cm of each power pin. Also, avoid placing the capacitor on the opposite side of the PC board from the AD9396, because that interposes resistive vias in the path.

The bypass capacitors should be physically located between the power plane and the power pin. Current should flow from the power plane to the capacitor to the power pin. Do not make the power connection between the capacitor and the power pin. Placing a via underneath the capacitor pads down to the power plane is generally the best approach.

It is particularly important to maintain low noise and good stability of PV_{DD} (the clock generator supply). Abrupt changes in PV_{DD} can result in similarly abrupt changes in sampling clock phase and frequency. This can be avoided by careful attention to regulation, filtering, and bypassing. It is highly desirable to provide separate regulated supplies for each of the analog circuitry groups (V_{D} and PV_{DD}).

Some graphic controllers use substantially different levels of power when active (during active picture time) and when idle (during HSYNC and VSYNC periods). This can result in a measurable change in the voltage supplied to the analog supply regulator, which can in turn produce changes in the regulated analog supply voltage. This can be mitigated by regulating the analog supply, or at least PV_{DD} , from a different, cleaner, power source (for example, from a 12 V supply).

It is recommended to use a single ground plane for the entire board. Experience has shown repeatedly that the noise performance is the same or better with a single ground plane. Using multiple ground planes can be detrimental because each separate ground plane is smaller and long ground loops can result.

When using separate ground planes is unavoidable, placing a single ground plane under the AD9396 is recommended. The location of the split should be at the receiver of the digital outputs. In this case it is even more important to place components wisely because the current loops are much longer, (current takes the path of least resistance). An example of a current loop is: power plane to AD9396 to digital output trace to digital data receiver to digital ground plane to analog ground plane .

PLL

Place the PLL loop filter components as close as possible to the FILT pin.

Do not place any digital or other high frequency traces near these components.

Use the values suggested in the data sheet with 10% tolerances or less.

AD9396

OUTPUTS (BOTH DATA AND CLOCKS)

Try to minimize the trace length that the digital outputs have to drive. Longer traces have higher capacitance, which require more current that causes more internal digital noise.

Shorter traces reduce the possibility of reflections.

Adding a series resistor of value $50\ \Omega$ to $200\ \Omega$ can suppress reflections, reduce EMI, and reduce the current spikes inside of the AD9396. If series resistors are used, place them as close as possible to the AD9396 pins (although try not to add vias or extra length to the output trace to move the resistors closer).

If possible, limit the capacitance that each of the digital outputs drives to less than $10\ \text{pF}$. This can be easily accomplished by keeping traces short and by connecting the outputs to only one device. Loading the outputs with excessive capacitance increases the current transients inside of the AD9396 and creates more digital noise on its power supplies.

DIGITAL INPUTS

The digital inputs on the AD9396 were designed to work with $3.3\ \text{V}$ signals, but are tolerant of $5.0\ \text{V}$ signals. Therefore, no extra components need to be added if using $5.0\ \text{V}$ logic.

Any noise that enters the HSYNC input trace can add jitter to the system. Therefore, minimize the trace length and do not run any digital or other high frequency traces near it.

COLOR SPACE CONVERTER (CSC) COMMON SETTINGS

Table 22. HDTV YCrCb (0 to 255) to RGB (0 to 255) (Default Setting for AD9396)

Register	Red/Cr Coeff 1		Red/Cr Coeff 2		Red/Cr Coeff 3		Red/Cr Offset	
Address	0x35	0x36	0x37	0x38	0x39	0x3A	0x3B	0x3C
Value	0x2C	0x52	0x08	0x00	0x00	0x00	0x19	0xD7
Register	Green/Y Coeff 1		Green/Y Coeff 2		Green/Y Coeff 3		Green/Y Offset	
Address	0x3D	0x3E	0x3F	0x40	0x41	0x42	0x43	0x44
Value	0x1C	0x54	0x08	0x00	0x3E	0x89	0x02	0x91
Register	Blue/Cb Coeff 1		Blue/Cb Coeff 2		Blue/Cb Coeff 3		Blue/Cb Offset	
Address	0x45	0x46	0x47	0x48	0x49	0x4A	0x4B	0x4C
Value	0x00	0x00	0x08	0x00	0x0E	0x87	0x18	0xBD

Table 23. HDTV YCrCb (16 to 235) to RGB (0 to 255)

Register	Red/Cr Coeff 1		Red/Cr Coeff 2		Red/Cr Coeff 3		Red/Cr Offset	
Address	0x35	0x36	0x37	0x38	0x39	0x3A	0x3B	0x3C
Value	0x47	0x2C	0x04	0xA8	0x00	0x00	0x1C	0x1F
Register	Green/Y Coeff 1		Green/Y Coeff 2		Green/Y Coeff 3		Green/Y Offset	
Address	0x3D	0x3E	0x3F	0x40	0x41	0x42	0x43	0x44
Value	0x1D	0xDD	0x04	0xA8	0x1F	0x26	0x01	0x34
Register	Blue/Cb Coeff 1		Blue/Cb Coeff 2		Blue/Cb Coeff 3		Blue/Cb Offset	
Address	0x45	0x46	0x47	0x48	0x49	0x4A	0x4B	0x4C
Value	0x00	0x00	0x04	0xA8	0x08	0x75	0x1B	0x7B

Table 24. SDTV YCrCb (0 to 255) to RGB (0 to 255)

Register	Red/Cr Coeff 1		Red/Cr Coeff 2		Red/Cr Coeff 3		Red/Cr Offset	
Address	0x35	0x36	0x37	0x38	0x39	0x3A	0x3B	0x3C
Value	0x2A	0xF8	0x08	0x00	0x00	0x00	0x1A	0x84
Register	Green/Y Coeff 1		Green/Y Coeff 2		Green/Y Coeff 3		Green/Y Offset	
Address	0x3D	0x3E	0x3F	0x40	0x41	0x42	0x43	0x44
Value	0x1A	0x6A	0x08	0x00	0x1D	0x50	0x04	0x23
Register	Blue/Cb Coeff. 1		Blue/Cb Coeff 2		Blue/Cb Coeff 3		Blue/Cb Offset	
Address	0x45	0x46	0x47	0x48	0x49	0x4A	0x4B	0x4C
Value	0x00	0x00	0x08	0x00	0x0D	0xDB	0x19	0x12

Table 25. SDTV YCrCb (16 to 235) to RGB (0 to 255)

Register	Red/Cr Coeff 1		Red/Cr Coeff 2		Red/Cr Coeff 3		Red/Cr Offset	
Address	0x35	0x36	0x37	0x38	0x39	0x3A	0x3B	0x3C
Value	0x46	0x63	0x04	0xA8	0x00	0x00	0x1C	0x84
Register	Green/Y Coeff 1		Green/Y Coeff 2		Green/Y Coeff 3		Green/Y Offset	
Address	0x3D	0x3E	0x3F	0x40	0x41	0x42	0x43	0x44
Value	0x1C	0xC0	0x04	0xA8	0x1E	0x6F	0x02	0x1E
Register	Blue/Cb Coeff 1		Blue/Cb Coeff 2		Blue/Cb Coeff 3		Blue/Cb Offset	
Address	0x45	0x46	0x47	0x48	0x49	0x4A	0x4B	0x4C
Value	0x00	0x00	0x04	0xA8	0x08	0x11	0x1B	0xAD

AD9396

Table 26. RGB (0 to 255) to HDTV YCrCb (0 to 255)

Register	Red/Cr Coeff 1		Red/Cr Coeff 2		Red/Cr Coeff 3		Red/Cr Offset	
Address	0x35	0x36	0x37	0x38	0x39	0x3A	0x3B	0x3C
Value	0x28	0x2D	0x18	0x93	0x1F	0x3F	0x08	0x00
Register	Green/Y Coeff 1		Green/Y Coeff 2		Green/Y Coeff 3		Green/Y Offset	
Address	0x3D	0x3E	0x3F	0x40	0x41	0x42	0x43	0x44
Value	0x03	0x68	0x0B	0x71	0x01	0x27	0x00	0x00
Register	Blue/Cb Coeff 1		Blue/Cb Coeff 2		Blue/Cb Coeff 3		Blue/Cb Offset	
Address	0x45	0x46	0x47	0x48	0x49	0x4A	0x4B	0x4C
Value	0x1E	0x21	0x19	0xB2	0x08	0x2D	0x08	0x00

Table 27. RGB (0 to 255) to HDTV YCrCb (16 to 235)

Register	Red/Cr Coeff 1		Red/Cr Coeff 2		Red/Cr Coeff 3		Red/Cr Offset	
Address	0x35	0x36	0x37	0x38	0x39	0x3A	0x3B	0x3C
Value	0x27	0x06	0x19	0xA0	0x1F	0x5B	0x08	0x00
Register	Green/Y Coeff 1		Green/Y Coeff 2		Green/Y Coeff 3		Green/Y Offset	
Address	0x3D	0x3E	0x3F	0x40	0x41	0x42	0x43	0x44
Value	0x02	0xED	0x09	0xD3	0x00	0xFD	0x01	0x00
Register	Blue/Cb Coeff 1		Blue/Cb Coeff 2		Blue/Cb Coeff 3		Blue/Cb Offset	
Address	0x45	0x46	0x47	0x48	0x49	0x4A	0x4B	0x4C
Value	0x1E	0x64	0x1A	0x96	0x07	0x06	0x08	0x00

Table 28. RGB (0 to 255) to SDTV YCrCb (0 to 255)

Register	Red/Cr Coeff 1		Red/Cr Coeff 2		Red/Cr Coeff 3		Red/Cr Offset	
Address	0x35	0x36	0x37	0x38	0x39	0x3A	0x3B	0x3C
Value	0x28	0x2D	0x19	0x27	0x1E	0xAC	0x08	0x00
Register	Green/Y Coeff 1		Green/Y Coeff 2		Green/Y Coeff 3		Green/Y Offset	
Address	0x3D	0x3E	0x3F	0x40	0x41	0x42	0x43	0x44
Value	0x04	0xC9	0x09	0x64	0x01	0xD3	0x00	0x00
Register	Blue/Cb Coeff 1		Blue/Cb Coeff 2		Blue/Cb Coeff 3		Blue/Cb Offset	
Address	0x45	0x46	0x47	0x48	0x49	0x4A	0x4B	0x4C
Value	0x1D	0x3F	0x1A	0x93	0x08	0x2D	0x08	0x00

Table 29. RGB (0 to 255) to SDTV YCrCb (16 to 235)

Register	Red/Cr Coeff 1		Red/Cr Coeff 2		Red/Cr Coeff 3		Red/Cr Offset	
Address	0x35	0x36	0x37	0x38	0x39	0x3A	0x3B	0x3C
Value	0x27	0x06	0x1A	0x1E	0x1E	0xDC	0x08	0x00
Register	Green/Y Coeff 1		Green/Y Coeff 2		Green/Y Coeff 3		Green/Y Offset	
Address	0x3D	0x3E	0x3F	0x40	0x41	0x42	0x43	0x44
Value	0x04	0x1C	0x08	0x11	0x01	0x91	0x01	0x00
Register	Blue/Cb Coeff 1		Blue/Cb Coeff 2		Blue/Cb Coeff 3		Blue/Cb Offset	
Address	0x45	0x46	0x47	0x48	0x49	0x4A	0x4B	0x4C
Value	0x1D	0xA3	0x1B	0x57	0x07	0x06	0x08	0x00

OUTLINE DIMENSIONS

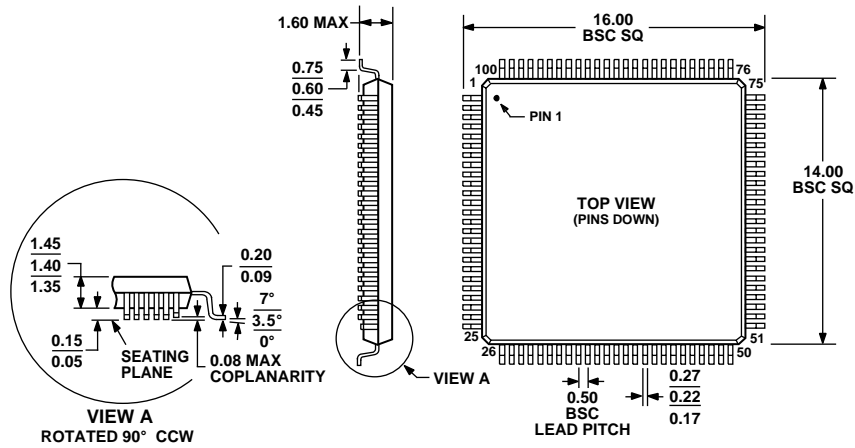

COMPLIANT TO JEDEC STANDARDS MS-026-BED

Figure 18. 100-Lead Low Profile Quad Flat Package [LQFP] (ST-100)
Dimensions shown in millimeters

ORDERING GUIDE

Model	Max Speeds (MHz)		Temperature Range	Package Description	Package Option
	Analog	Digital			
AD9396KSTZ-100 ¹	100	100	0°C to 70°C	100-Lead Low Profile Quad Flat Package (LQFP)	ST-100
AD9396KSTZ-150 ¹	150	150	0°C to 70°C	100-Lead Low Profile Quad Flat Package (LQFP)	ST-100
AD9396/PCB				Evaluation Board	

¹ Z = Pb-free part.

AD9396

NOTES

NOTES

AD9396

NOTES

Purchase of licensed I²C components of Analog Devices or one of its sublicensed Associated Companies conveys a license for the purchaser under the Philips I²C Patent Rights to use these components in an I²C system, provided that the system conforms to the I²C Standard Specification as defined by Philips.