

TONE / PULSE SWITCHABLE DIALER WITH HANDFREE FUNCTION

DESCRIPTION

The SC91710A/B are Tone/Pulse switchable dialer which are fabricated in COMS technology with wide operating voltage for both tone and pulse mode, and consumes very low memory retention current in ON-HOOK state.

FEATURES

- *Tone/Pulse switchable dialer
- *One 32-digit last number redial memory
- *Pulse-to-tone (P→T) is provided for PBX operation
- *Flash key is available
- *Minimum tone duration is 98ms or 83ms
- *Minimum intertone pause is 98ms or 83ms
- *Redial Pause time (0ms)
- *Uses 3.579549MHz crystal or ceramic resonator
- *Many options can be selected
 - Mode (10PPS; 20PPS; Tone)
 - M/B ratio (40:60;33:66)
 - Pause time (3.6s)
- *Flash function (RESET)
 - (P→T) pause time (3.6s)
 - Flash time (600ms; 300ms; 100ms; or 80ms)

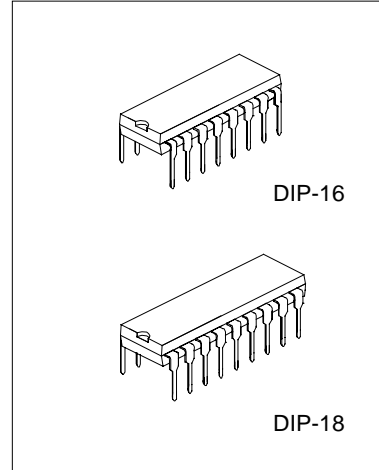

- *Mixed dialing
- *Power on reset circuit is provided
- *Handfree function is provided for speaker phone application
- *Packaged in 16-DIP or 18-DIP

ORDERING INFORMATION

SC91710A	DIP-16 Packaged
SC91710B	DIP-18 Packaged

PIN CONFIGURATION

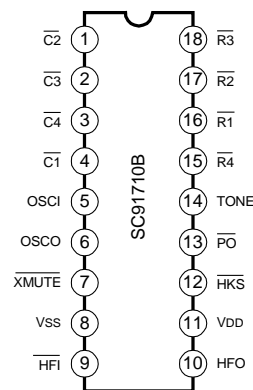
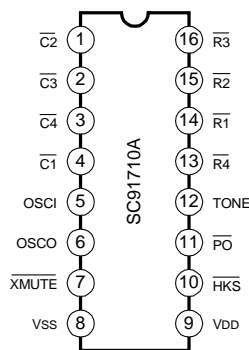

BLOCK DIAGRAM

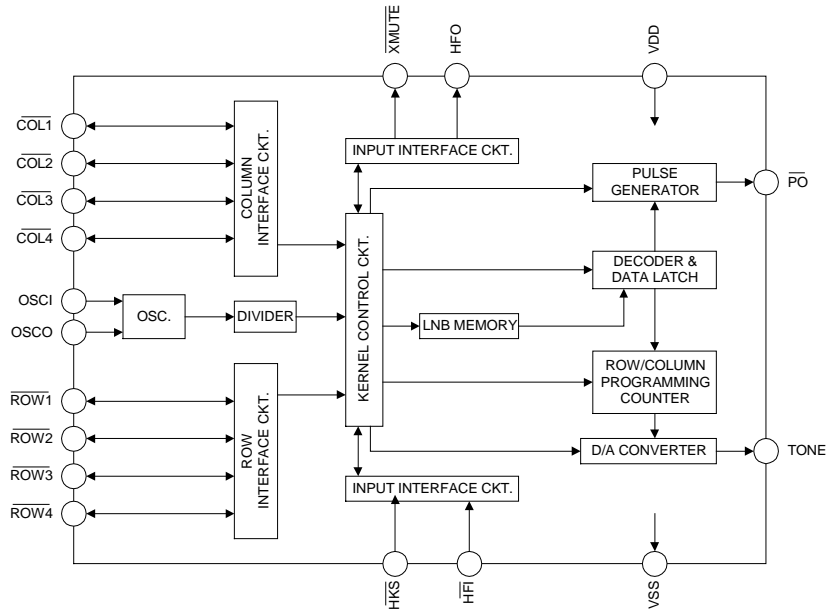

KEYBOARD ASSIGNMENT

	C1	C2	C3	C4
R1	1	2	3	P→T
R2	4	5	6	F
R3	7	8	9	P
R4	*or */T	0	#	RD

- 1) P→T: In pulse mode, execute P→T function.
- 2) P: Pause key.
- 3) F: Flash key
- 4) RD: Redial key
- 5) In pulse mode, execute P→T function.
In tone mode, execute "*" key

DIALING SIGNAL OPTION

A: Flash time

Row3	Row4	Flash time(ms)
NR	NR	600
NR	R	300
R	NR	100
R	R	80

B:

Row1	Row2	MODE	PULSE RATE	M/B
R	NR	TONE	--	--
R	R	TONE	--	--
NR	NR	PULSE	20PPS	40:60
NR	R	PULSE	20PPS	33:66
UR	NR	PULSE	10PPS	40:60
UR	R	PULSE	10PPS	33:66

C: Tone function

Col1	Tone Duration	Inter-Tone Pause
NR	98ms	98ms
R	83ms	83ms

D: Key type select

Col2	*or */T select
NR	*
R	*/T

Note: NR: no resistance

R: A resistance connect to VSS (820kΩ typically)

UR: A resistance connect to VDD

ABSOLUTE MAXIMUM RATINGS

(Tamb=25°C, All voltage referenced to VSS, unless otherwise specified)

Characteristic	Symbol	Value	Unit
Power Supply Voltage	VDD	6.0	V
Input Voltage	VIN	-0.3~VDD+0.3	V
Power Dissipation	PD	500	mW
Operating Temperature	Topr	-25~+70	°C
Storage Temperature	Tstg	-55~+150	°C

ELECTRICAL CHARACTERISTICS

(Tamb=25°C, VDD=2.5V, fosc=3.579545MHz, unless otherwise specified)

Parameter	Symbol	Conditions	Min	Typ	Max	Unit	
DC Characteristics							
Operating Voltage	VDD	Tone	2.5	--	5.5	V	
		Pulse	2.0	--	5.5		
		Memory retention	1.0	--	5.5		
Operating Current	IOP	Tone	OFF-HOOK,	--	0.6	2	mA
		Pulse	Keypad entry	--	0.2	0.5	
Standby Current	Is	ON-HOOK, No keypad entry	--	0.1	1	μA	
Memory Retention Current	Imr	ON-HOOK, VDD=1.0V	--	0.1	0.2	μA	
Control Pin Input Low Voltage	Vil	--	VSS	--	0.3VDD	V	
Control Pin Input High Voltage	Vih	--	0.7VDD	--	VDD		
\overline{XMUTE} Pin Leakage Current	Imth	$V_{\overline{XMUTE}}=6.0V$	--	--	1	μA	
\overline{XMUTE} Pin Sink Current	Imtl	$V_{\overline{XMUTE}}=0.5V$	0.2	0.5	--	mA	
\overline{HKS} Pin Input Current	Ihks	Vhks=2.5V	--	--	0.1	μA	
Keyboard	Drive Current	Ikbd	Vn=0V (note1)	4	10	30	μA
Scanning Pin	Sink Current	Ikbs	Vn=2.5 (note1)	200	400	800	
Key-in Debounce Time	tDB	--	--	20	--	ms	

(to be continued)

(continued)

Parameter	Symbol	Conditions	Min	Typ	Max	Unit	
HFI pin input resistor	Rhfi	VDD=2.5	--	200	--	kΩ	
HFO pin drive current	Ihdoh	Vhfo=2.0V	0.5	--	--	mA	
HFO pin sink current	Ihdol	Vhfo=2.5V	0.5	--	--	mA	
Pulse Mode							
Pulse Output Pin Leakage Current	I _{poh}	V _{po} =2.5V	0.1	--	--	μA	
Pulse Output Pin Sink Current	I _{pol}	V _{po} =0.5V	0.5	--	--	mA	
Pulse Rate	f _{pr}		--	10	--	pps	
			--	20	--		
Make/Break Ratio	t _M : t _B		--	40:60	--	%	
			--	33:66	--		
Pre-digit Pause	t _{PDP}	M/B ratio=40:60	--	40	--	ms	
		M/B ratio=33:66	--	33	--		
Inter-digit Pause	t _{IDP}	Pulse rate=10pps	--	800	--	ms	
		Pulse rate=20pps	--	500	--		
Tone Mode							
Tone Output Pin	DC Level	V _{dc}	VDD=2.0V~5.5V	0.5VDD	--	0.7VDD	V
	Sink Current	I _{tl}	V _{dtmf} =0.5V	0.2	--	--	mA
	AC level	V _{dtmf}	Row group, R _L =10KΩ	130	155	170	mVrms
	Load Resistor	R _L	Dist.≤ -23dB	10	--	--	KΩ
DTMF Signal	Pre-emphasis	twist	VDD=2.0~5.5 V, Column-Row group	1	2	3	dB
	Distortion(note 2)	Dist.	R _L =10KΩ	--	-30	-23	dB
Minimum tone duration Time	t _{TD}	Auto redial	--	98/83	--	ms	
Minimum Intertone Pause Time	t _{ITP}	Auto redial	--	98/83	--	ms	

Note: 1. V_n: Input voltage of any keyboard scanning pin (Row group, Column group)

$$2. \text{Distortion (dB)} = 20\log\left\{\frac{[V_1^2+V_2^2+V_3^2+\dots+V_n^2]^{1/2}}{[(V_L^2+V_H^2)^{1/2}]}\right\}$$

V_L,V_H: Row group and Column group signal , V₁, V₂... V_n: Harmonic signal (BW = 300Hz~3500Hz)

ACTUAL FREQUENCY OUTPUT (f_{osc}=3.579545MHz)

Keyboard Scanning Pin	Standard(Hz)	Output	Deviation(%)
R1	f1	697	+0.28
R2	f2	770	-0.52
R3	f3	852	-0.47
R4	f4	941	+0.74
C1	f5	1209	+0.57
C2	f6	1336	-0.30
C3	f7	1477	-0.34

————— **HANGZHOU SILAN MICROELECTRONICS JOINT-STOCK CO.,LTD** —————

Rev: 2.0 2001-11-13

PIN DESCRIPTION

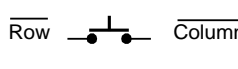
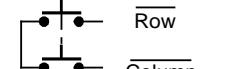
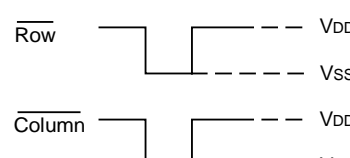
Pin No.		Pin Name	Description
SC91710A	SC91710B		
4	4	$\overline{C1}$	<p>*Provides keyboard scanning.</p> <p>*\overline{HKS} pin is LOW, the column group stays in "HIGH" state and row group stays in "LOW" state.</p>
1	1	$\overline{C2}$	<p>*The keypad is compatible with the standard dual contact matrix keyboard (as figure1b), the inexpensive single contact keyboard (as figure 1a), and electronic input (as figure 1c).</p>
2	2	$\overline{C3}$	<p>*When \overline{HKS} is "LOW", a valid key entry is defined by related Row & Column connection or by electronic input (as shown in figure 1c).</p>
3	3	$\overline{C4}$	<p>*Activation of two or more keys will result in no response, except for single key.</p>
14	16	$\overline{R1}$	<p>*To avoid keyboard-bouncing error, this chip provides built-in debounce circuit. (The debounce time = 20ms)</p>
15	17	$\overline{R2}$	<div style="display: flex; justify-content: space-around;"> <div style="text-align: center;">  <p>Figure1a: Single contact form keyboard configuration</p> </div> <div style="text-align: center;">  <p>Figure1b: Dual contact form keyboard configuration</p> </div> </div>
16	18	$\overline{R3}$	<div style="text-align: center;">  <p>Figure1c: Electronic signal input keyboard configuration</p> </div>
13	15	$\overline{R4}$	
5	5	OSCI	<p>*Oscillator input & output pins.</p>
6	6	OSCO	<p>*The 3.579545MHz oscillator is formed by a built-in inverter inside of this chip and by connecting a 3.579545MHz crystal or a ceramic resonator across the OSCI and OSCO pins. (built-in feedback resistor and capacitor)</p> <p>*When \overline{HKS} is "LOW", a valid key-in may turn on this oscillator and generates a 3.579545 MHz clock.</p>

(to be continued)

(continued)

Pin No.		Pin Name	Description
SC91710 A	SC91710B		
7	7	$\overline{\text{XMUTE}}$	<p>*Mute output pins. *NMOS open drain output structure. *The output is in "LOW" state during dialing sequence (both Pulse and Tone mode) otherwise this pin is "high-impedance". *Long (continue) Mute.</p>
8	8	VSS	*Negative power supply pin.
9	11	VDD	*Positive power supply pin.
10	12	$\overline{\text{HKS}}$	<p>*Hook switch input pin. *When the handset is in ON-HOOK state, this pin must be pulled "high" in order to disable the dialing operation and decrease the power consumption. *When in OFF-HOOK state, the $\overline{\text{HKS}}$ pin must be pulled "low" state for all function operation.</p>
11	13	$\overline{\text{PO}}$	<p>*Pulse output signal pin. *NMOS open drain output structure. *The output is "LOW" during pulse dialing and Flash operation, otherwise this output is "floating".</p>
12	14	TONE	<p>*Dual Tone Multi-frequency output pin. *In TONE mode, when an entry of digit key (include *, # key), this pin will send out a corresponding DTMF signal. *The TONE pin provides minimum tone duration and minimum intertone pause time to support rapid key-in. If key-in time is less than 100ms, DTMF signal will last for 100ms; otherwise the tone duration will last as long as the key is pressed.</p>
	9	$\overline{\text{HFI}}$	<p>* Handfree input control pin. * Toggle input structure, falling edge trigger. * It is used to enable and disable Handfree function. * With waveshaped by a built-in Schmit trigger, the bounce of input can be eliminated by external R, C debounce circuit. * A built-in pull down resistor is 200k typical.</p>
	10	HFO	<p>* Handfree output control pin. * Inverter output structure (normally 'low', active 'high'). * When a HFI pin is active, Handfree function will be enabled (HFO=1) or disable (HFO=0). * When the Handfree function is enable (HFO=1), after OFF-HOOK action, it can reset Handfree function and HFO pin return to 'low' state.</p>

KEYBOARD OPERATION

Symbol definitions:

- a) \uparrow : OFF-HOOK or enable Hand Free function.
- b) \downarrow : ON-HOOK or disable Hand Free function.
- c) \uparrow (with horizontal line) : Input level from low to high.
- d) \downarrow (with horizontal line) : Input level from high to low.
- e) D1~Dn : Digit key: 1, 2, 3, 4, 5, 6, 7, 8, 9, 0, *, #, (C1~Cn is same as D1~Dn).
- f) Dp1~Dpn : Pulse digit: 1, 2, 3, 4, 5, 6, 7, 8, 9, 0, (Cp1~Cpn is same as Dp1~Dpn).
- g) Dt1~Dtn : Tone digit: 1, 2, 3, 4, 5, 6, 7, 8, 9, 0, *, #, (Ct1~Ctn is same as Dt1~Dtn).
- h) t_F : Flash time.
- i) t_P : Pause time.
- j) t_{PT} : Pulse to Tone wait time.
- k) t_{FP} : Pause time for flash.
- l) t_{RP} : Pause time for redial.
- m) LNB : Last number redial buffer.

A) Normal Dialing

1. Digit Dialing

Procedure : \uparrow D1, D2..., Dn \downarrow
 Dial out : Dt1, Dt2..., Dtn (in Tone mode)
 Dial out : Dp1, Dp2..., Dpn (in Pulse mode)
 LNB : D1, D2..., Dn

2. Dialing with flash key

Procedure : \uparrow F, D1, D2..., Dn \downarrow
 Dial out : t_F , t_{FP} , Dt1, Dt2..., Dtn (in Tone mode)
 Dial out : t_F , t_{FP} , Dp1, Dp2, ..., Dpn (in Pulse mode)
 LNB : D1, D2..., Dn

3. Dialing with P→T key

Procedure : \uparrow D1, D2 ..., P→T, ..., Dn \downarrow
 Dial out : Dp1, Dp2, ..., t_{PT} , ..., Dpn (in Pulse mode)
 LNB : D1, D2 ..., P→T, ..., Dn

Note: If key in digit over maximum digit stored in LNB, then RD is inhibit even after on/off hook.

B) Mixed dialing

Procedure	:	↑D1, D2..., P→T, D9, D10 ..., Dn↓
Dial out	:	Dp1, Dp2, ..., t _{PT} , Dt9, Dt10..., Dtn
LNB	:	D1, D2..., P→T, D9, D10 ..., Dn

C) Redial

LNB	:	D1, D2..., Dn
Procedure	:	↑ RD ↓
Dial out	:	t _{RP} , Dt1, Dt2..., Dtn (in Tone mode)
Dial out	:	t _{RP} , Dp1, Dp2..., Dpn (in Pulse mode)

Note: If key in digit over maximum digit stored in LNB, then RD is inhibit.

D) Pause Function

Procedure	:	↑ D1, D2..., Dn, P, C1 ..., Cn ↓
Dial out	:	Dt1, Dt2, ..., Dtn, t _P , Ct1, Ctn (in Tone mode)
Dial out	:	Dp1, Dp2, ... Dpn, t _P , Cp1 ..., Cpn (in Pulse mode)
LNB	:	D1, D2..., Dn, P, C1, C2 ..., Cn

E) Flash Function

1. Reset

Procedure	:	↑ D1, D2..., Dn, F, C1 ..., Cn ↓
Dial out	:	Dt1, Dt2, ..., Dtn, t _F , t _{FP} , Ct1 ..., Ctn (in Tone mode)
Dial out	:	Dp1, Dp2, ..., Dpn, t _F , t _{FP} , Cp1 ..., Cpn (in Pulse mode)
LNB	:	C1, C2 ..., Cn

Handfree Function operation:

A) To execute Handfree function: When HFO = 'low', HFI pin is active, the Handfree function will be enabled (HFO = 'high')

B) Reset Handfree function:

a. OFF-HOOK action.

b. When HFO = 'high', a HFI pin is active again, the Handfree function will be reset (HFO='low').

Operating flow chart of Handfree

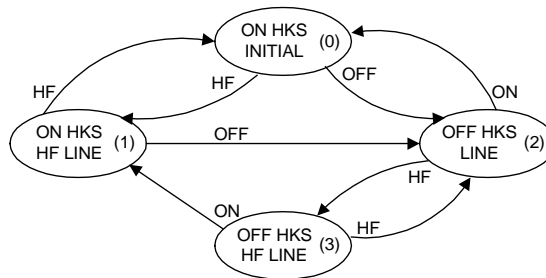

Note: ON: ON HKS; OFF: OFF HKS; HF: Pressed HF key

STATE NO.	\overline{PO}	\overline{XMUTE}	HFO
(0) INITIAL STATE	F	F	0
(1) ON HKS HF LINE	F	F	1
(2) OFF HKS LINE	F	F	0
(3) OFF HKS HF LINE	F	F	1

* F: Floating
(Hi-impedance)

TEST CIRCUIT

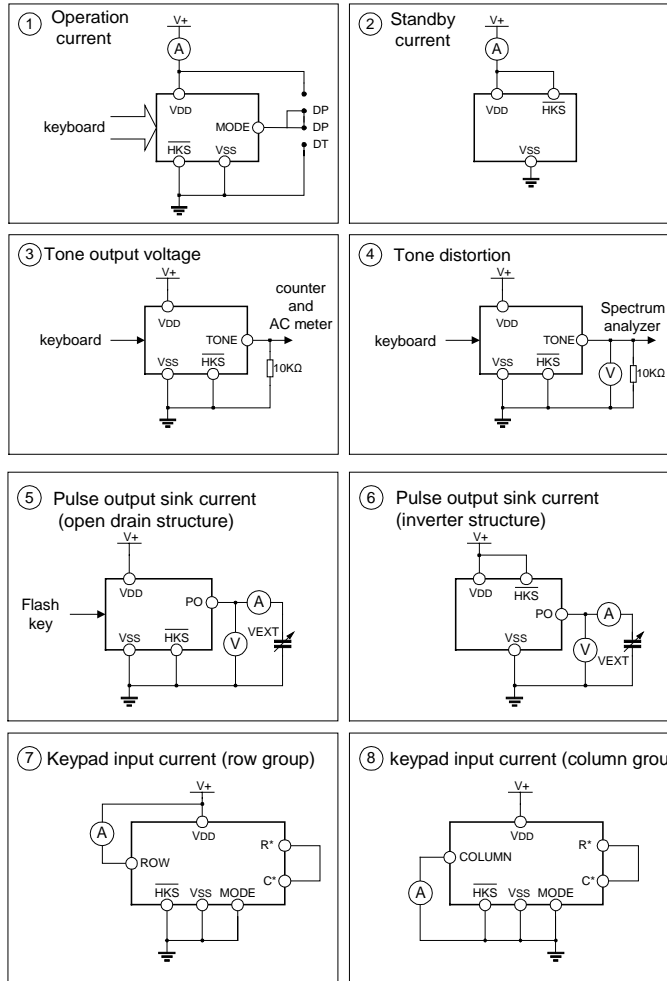

Note: 1. Dist. (dB)=20log{[V₁²+V₂²+V₃²+...V_n²]^{1/2}}/[(V_L²+V_H²)^{1/2}]

a. V₁...V_n are extraneous frequencies (ie, inter modulation and harmonic), components in the 500Hz

to

3400Hz band.

b. V_L,V_H are the individual frequency components of DTMF signal.

c. Whether keyboard is pushed refer to the TONE mode time diagram.

2. Sink current Isink=I/(1-Duty Cycle), I is the net DC current measured from ampere meter.

3. R*, C* mean other column and row.

————— HANGZHOU SILAN MICROELECTRONICS JOINT-STOCK CO.,LTD —————

Rev: 2.0 2001-11-13

TIMING DIAGRAMS (continued)

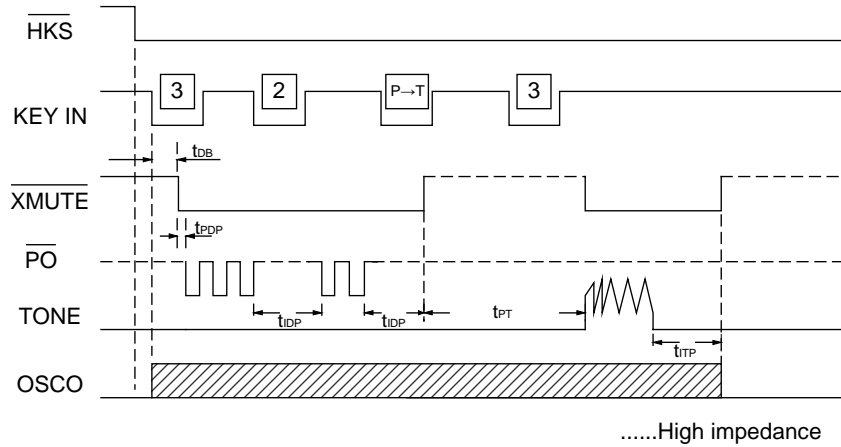

.....High impedance
Timing Waveform for mixed dialing Operation
(by P→T key entry)

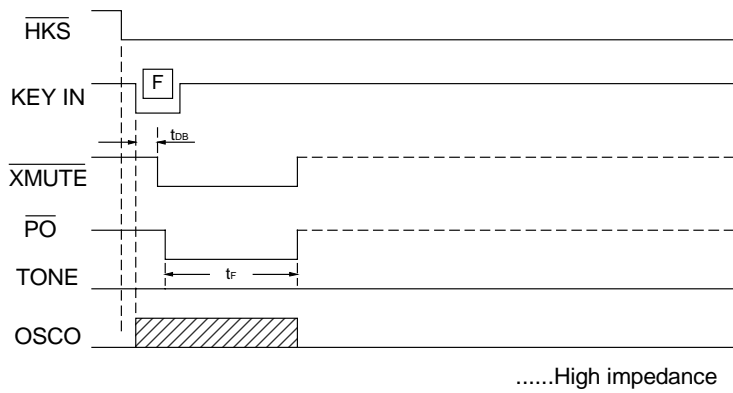

.....High impedance
Flash key operating timing

TIMING DIAGRAMS(continued)

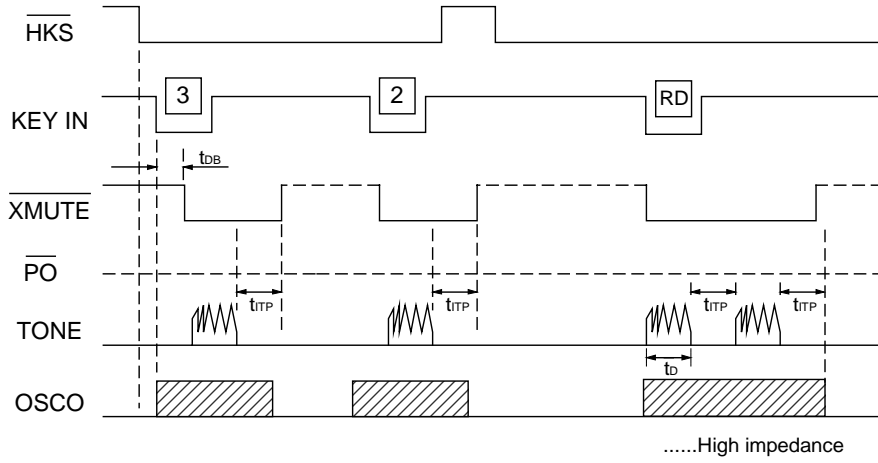

Tone Mode Redial Timing Diagram

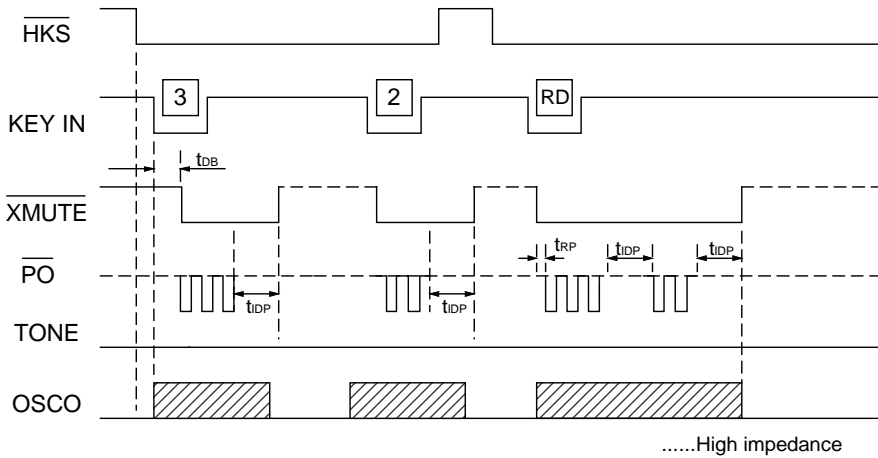

Pulse Mode Redial Timing Diagram

TIMING DIAGRAMS(continued)

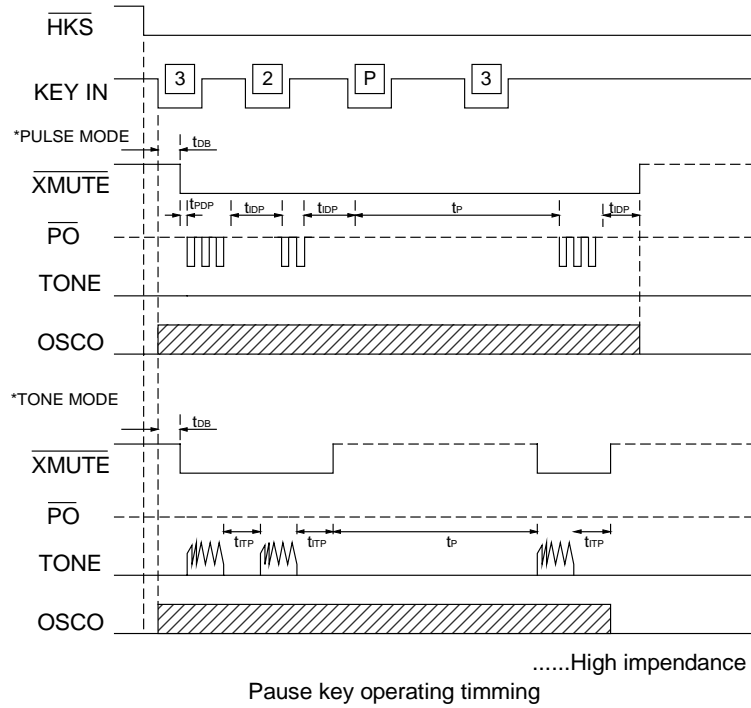

TYPICAL APPLICATION CIRCUIT

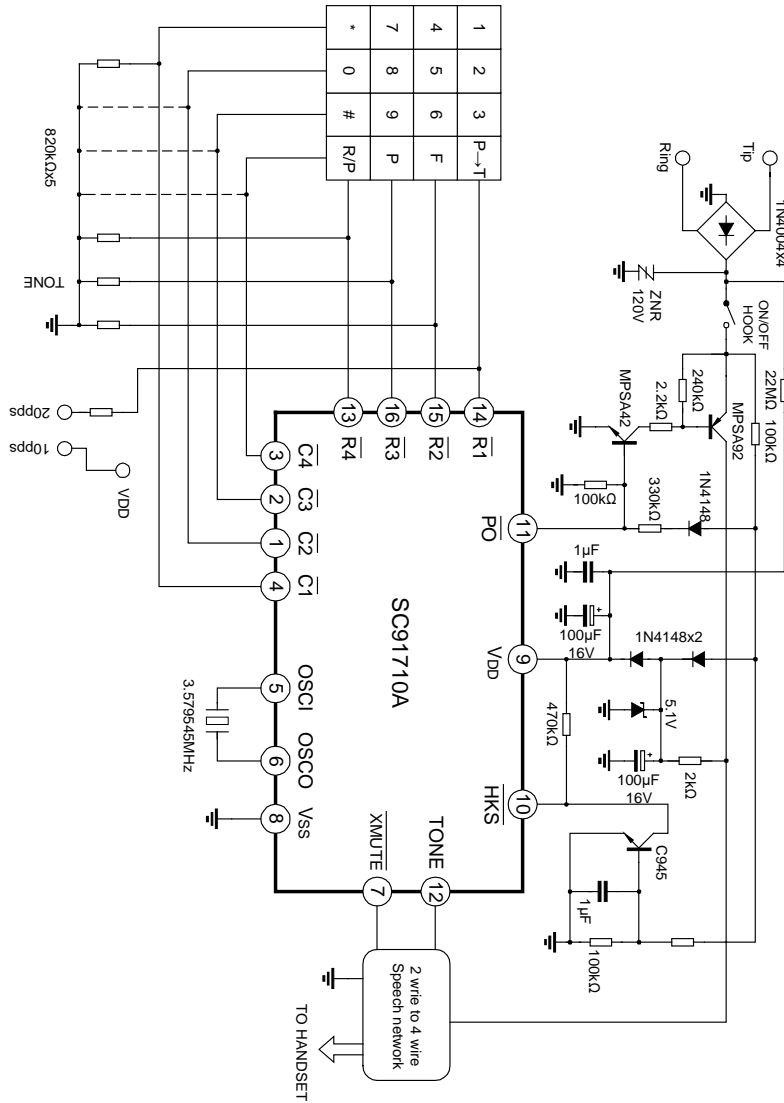

TYPICAL APPLICATION CIRCUIT

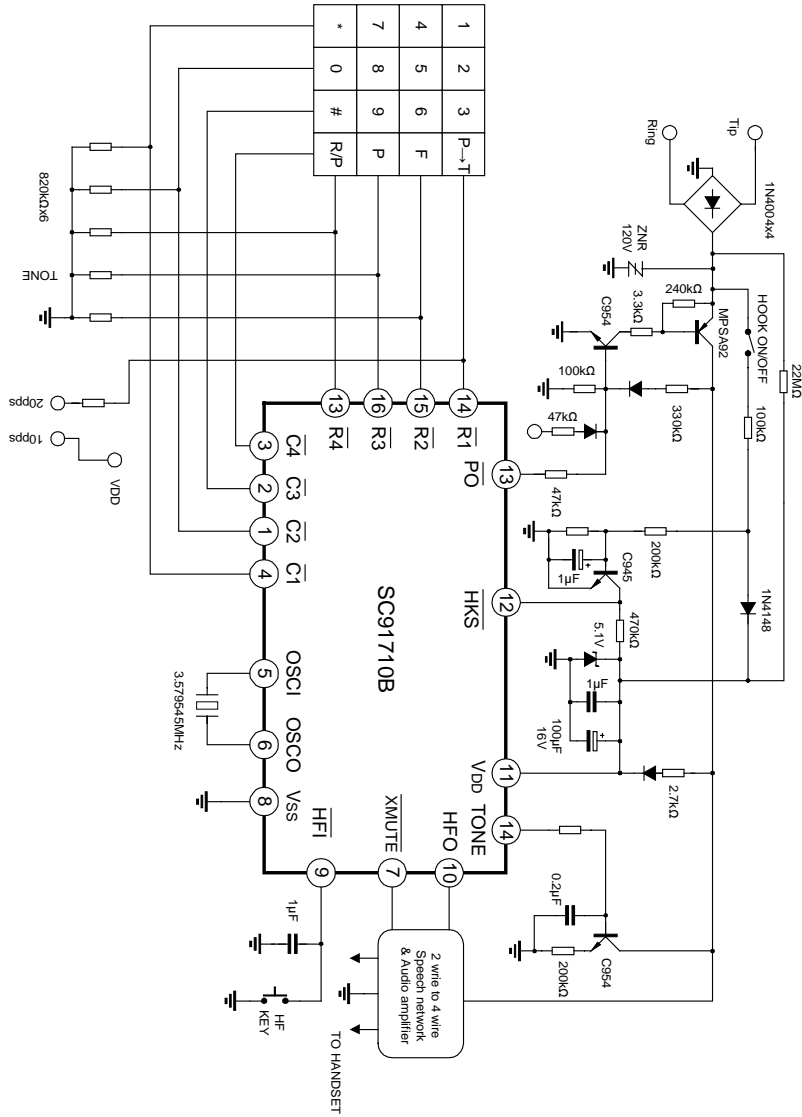

CHIP TOPOGRAPHY



Size: 1.45 x 1.54 mm²

PAD COORDINATES (Unit: μm)

No.	Symbol	X	Y	No.	Symbol	X	Y
1	P1	-542.6	-238.0	10	P10	562.4	88.5
2	P2	-542.6	-468.1	11	P11	562.4	252.4
3	P3	-542.6	-602.5	12	P12	562.4	445.8
4	P4	-315.0	-602.5	13	P13	562.4	603.8
5	P5	-134.8	-602.5	14	P14	148.6	603.8
6	P6	85.5	-602.5	15	P15	-22.4	603.8
7	P7	562.4	-439.1	16	P16	-251.0	603.8
8	P8	562.4	-277.6	17	P17	-542.6	124.7
9	P9	562.4	-93.6	18	P18	-542.6	-102.9

Note: The original point of the coordinate is the die center.

PACKAGE OUTLINE

