

Feature

- Operating Voltage:2.5V to 6.0V.
- High Operating Frequency: 1.4MHz
- High Output Voltage: Up to 28V
- Shutdown Current <math><1\mu A</math>
- Digital Dimming Control.
- Built-in Cycle-by Cycle Current-Limiting.
- Built-in Soft-Start Function.
- $\pm 1.5\%$ 1.23V Reference Voltage
- Tiny SOT-25 Package

Description

The AT1309 step-up converter is designed for small or medium size LCD panel of high bias voltage with a constant current to provide PDAs, and other hand-held devices. It features a fast 1.4 MHz current-mode PWM control with a built-in 0.3Ω N-MOS that allows for smaller capacitor and inductor. Fault condition protection uses cycle-by-cycle current limiting to sense maximum inductor current and thermal protection. Also included soft-start eliminates inrush current during start-up.

The AT1309 is available in 5-pin SOT-25 packages.

Application

- STN/OLED Bias
- Personal Digital Assistants(PDAs)
- DSC

Block Diagram

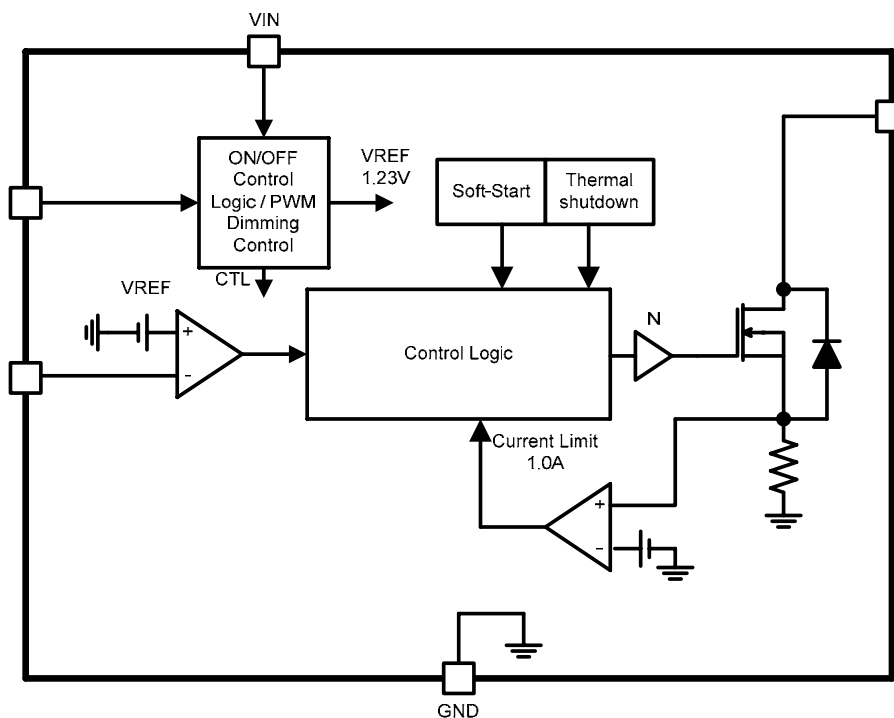

Aimtron reserves the right without notice to change this circuitry and specifications.

Pin Configuration

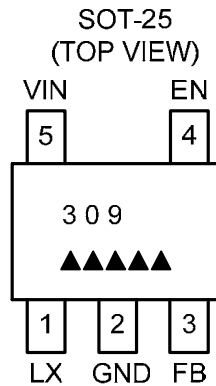

Ordering Information

Part number	Package	Marking
AT1309X	SOT-25	▲▲▲▲▲ Date Code
AT1309X_GRE	SOT-25, Green	▲▲▲▲▲, Date Code with one bottom line

▲▲▲▲▲ : Date Code

**For more marking information, contact our sales representative directly*

Pin Description

Pin N0.	Symbol	I / O	Description
1	LX	I	Step-up Regulator N-MOS Drain. Place output diode and inductor.
2	GND	P	Ground
3	FB	I	Step-Up Regulator Feedback Input. Connect a sense resistor from FB to ground.
4	EN	I	Enable and Dimming Control Input. LED brightness and IC shutdown are controlled by the voltage on EN. Driving low for longer than 4ms to shutdown the IC.
5	VIN	P	Power supply.

Absolute Maximum Ratings*1

Parameter		Rated Value	Unit
VIN voltage		-0.3 to +6.5	V
LX voltage		-0.3 to +30	V
EN , FB to GND		-0.3 to +6.5	V
Switch Current (I _{LX})		1.8	A
Continuous power dissipation (SOT-25 Ta=+25 ⁰ C)		0.25	W
Operating Junction Temperature Range		-30 to 85	°C
Lead Temperature (Soldering 5 sec)		260	°C
Storage Temperature		-65 to 125	°C
Package Thermal Resistance (Θ _{JA})		250	°C/W
ESD Susceptibility*2	HBM	2	KV
	MM	200	V

1. Stresses beyond those listed under “Absolute Maximum Ratings” may cause permanent damage to the device. These are stress ratings only, and functional operation of the device at these or any other conditions beyond those indicated in the operational sections of the specifications is not implied. Exposure to absolute maximum rating conditions for extended periods may affect device reliability.
2. Device are ESD sensitive. Handling precaution recommended. The Human Body model is a 100pF capacitor discharged through a 1.5KΩ resistor into each pin.

Recommended Operation Conditions

Parameter	Symbol	Values			Unit
		Min.	Typ.	Max.	
Power supply voltage	V _{IN}	2.5	—	6.0	V
Operating temperature	Top	-20	+25	+85	°C

Electrical Characteristics

 ($V_{IN}=2.5V$, $T_a=+25^{\circ}C$, unless otherwise noted)

Parameter	Symbol	Test Condition	Min.	Typ.	Max.	Units
Operating V_{IN} Range	V_{IN}	V_{IN} input Voltage	2.5	-	6.0	V
Under Voltage Thershold	UVLO	V_{IN} falling, 100mV hysteresis	2.1	2.2	2.3	V
Switch- Off Input Current	I_{IN1}	No Switching	-	100	120	μA
Shutdown Current	I_{IN3}	EN=0V	-	-	1	μA
Feedback Reference	V_{FB}		1.212	1.230	1.248	V
FB Input Bias Current	I_{FB}	$V_{FB}=0.2V$	-	-	1	μA
Output Voltage Line Regulation		$2.5V < V_{IN} < 6.0V$	-	0.1	-	%
Switching Frequency	f_{OSC}		-	1.4	-	MHz
Maximum Duty	D_{MAX}		-	90	-	%
Soft-Start charging time	t_{SS}		-	0.5	-	ms
Switching Current Limit	I_{LX}	$V_{IN}=3.0V$, duty cycle=80%	-	1.0	-	A
LX ON Resistance	R_{LX}	$I_{LX}=350mA$	-	0.3	-	Ω
LX Leakage Current	$I_{Leakage}$	$V_{LX}=28V$, EN=0V	-	-	1	μA
EN Input Current	I_{EN}	EN=5V	-	-	8	μA
EN Input Level	V_{IH}	0.1V hysteresis	2.0	-	-	V
	V_{IL}		-	-	0.8	V
EN low Shutdown Delay			-	4	-	ms
Thermal Shutdown			-	120	-	

Typical Characteristics

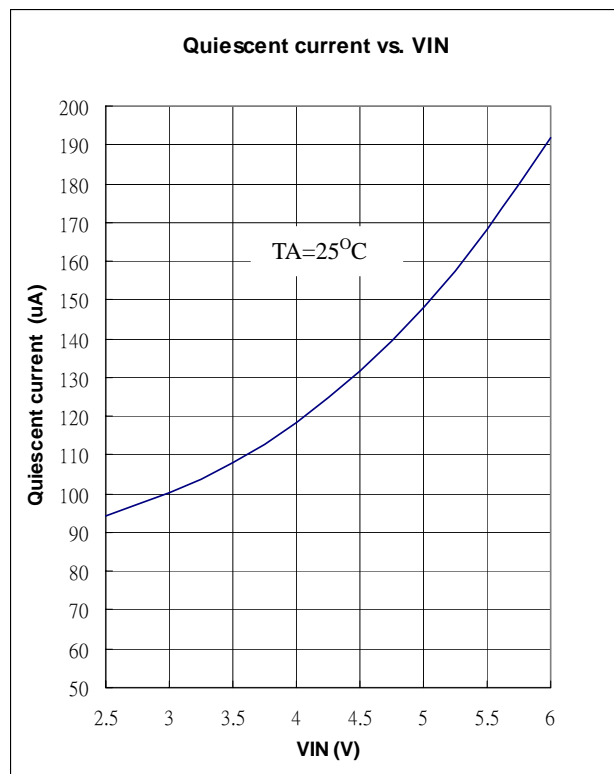
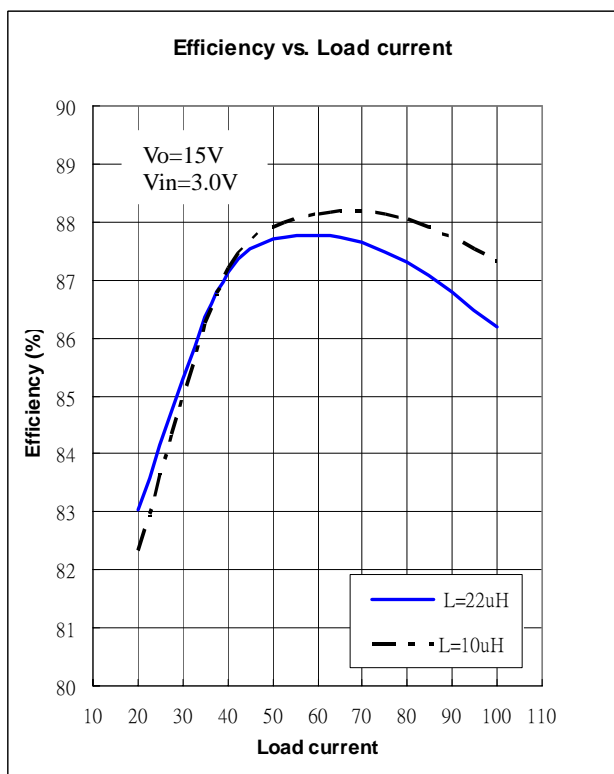
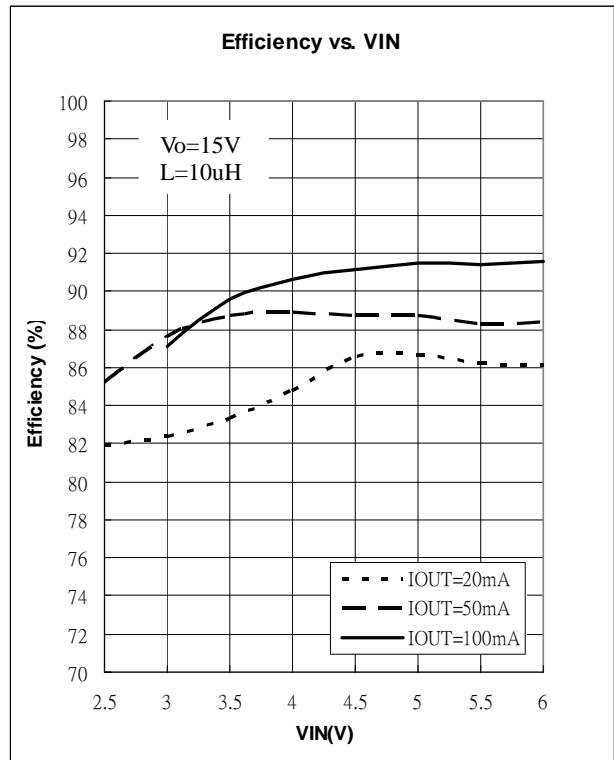
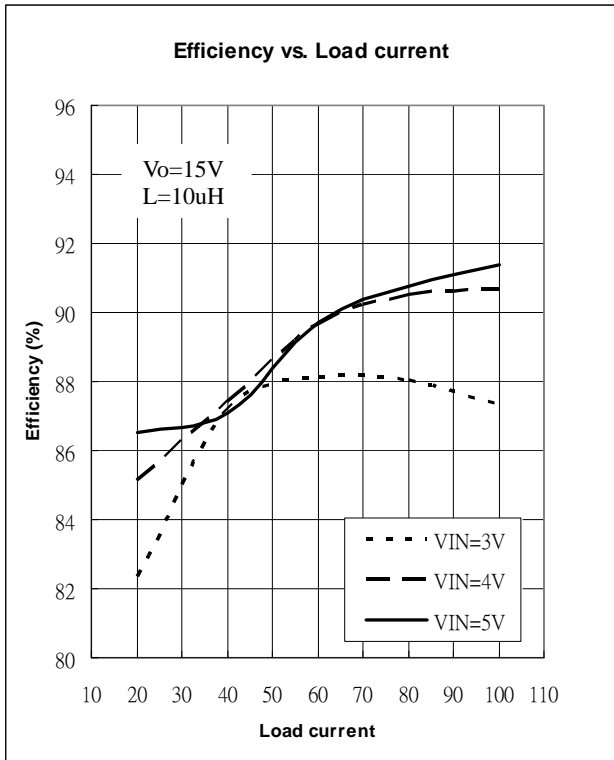

Load Transient Response

VIN=3.0V, Vout=15V, L=10uH, Iout=10mA to 100mA

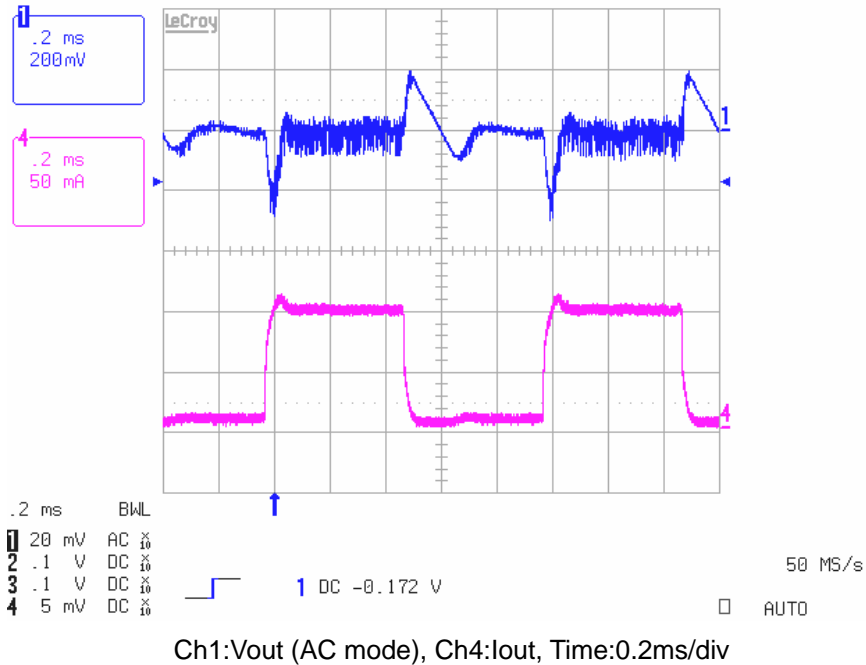

Line Transient Response

VIN=3.0V to 6.0V, Vout=15V, L=10uH, Iout=100mA

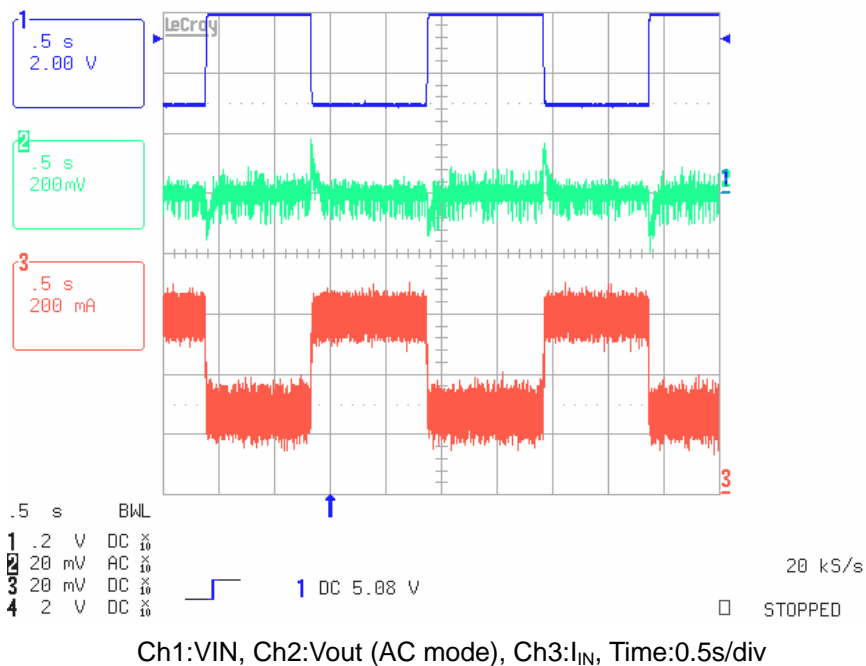

Start up Waveform with Load

VIN=3.0V, Vout=15V, L=10uH, Iout=100mA

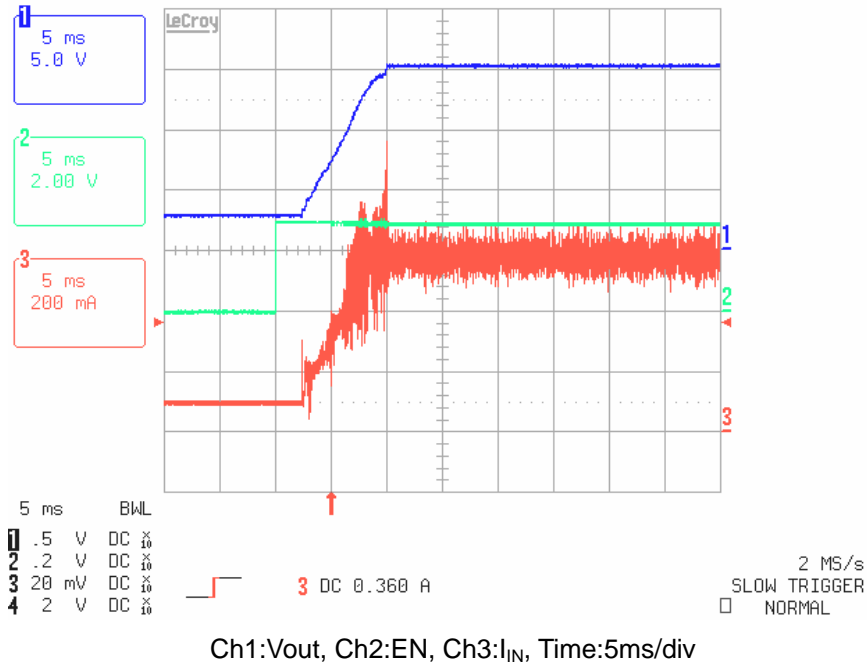

LX Switching Waveform

VIN=3.0V, Vout=15V, L=10uH

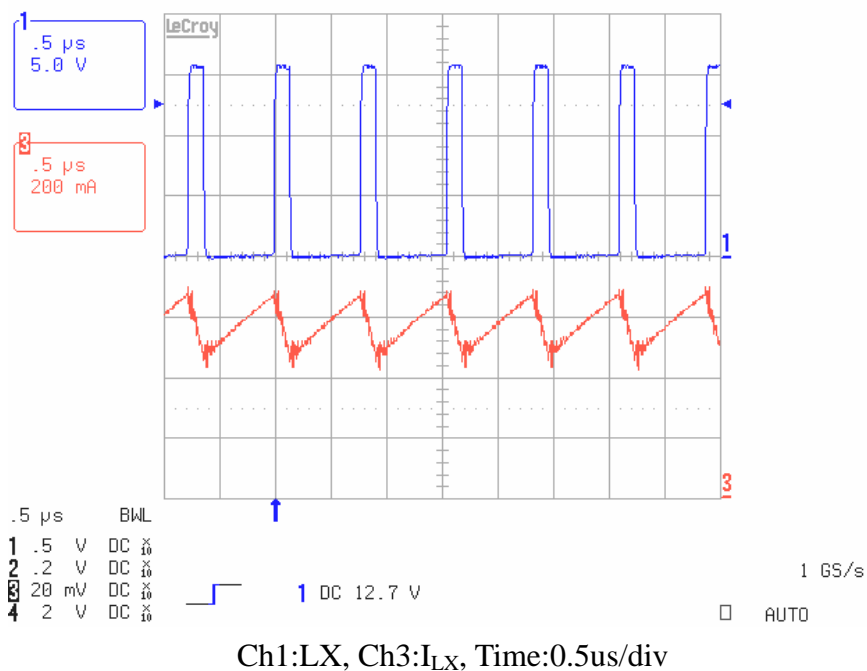

Application Circuit

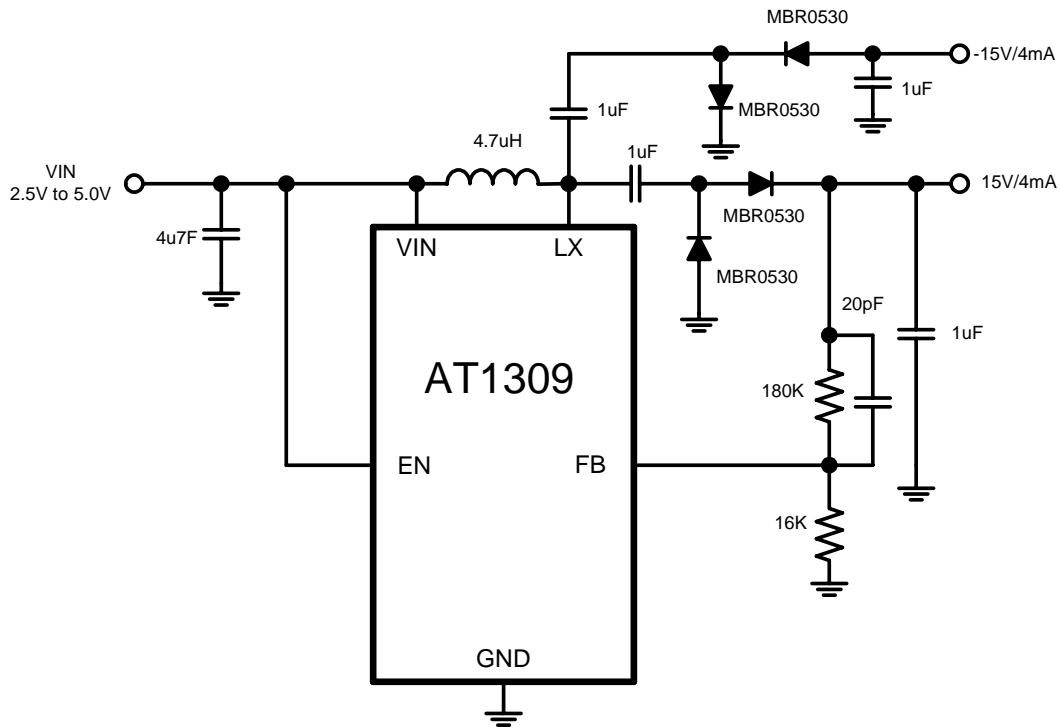

Fig3. ±15V Dual Output Converter

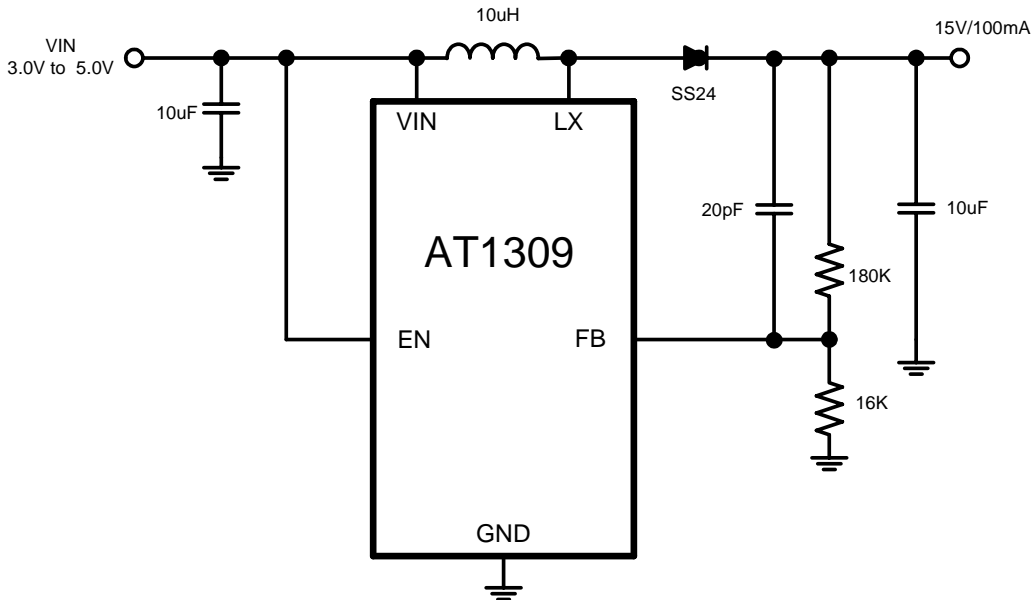

Fig4. 15V Boost Converter

Function Description

The AT1309 is designed primarily for use in STN/OLED bias applications. The output voltage of the step-up converter can be set from V_{in} to 26V with external resistive voltage divider. The boost converter operates in current-mode PWM and a constant frequency of 1.0 MHz. Depending on duty cycle of each switching cycle can regulate output voltage. On the rising edge of the internal clock, the control and driver logic block sets internal flip-flop when the output voltage is too low, which turns on the N-MOS. The external inductor current ramps up linearly, storing energy in a magnetic field. Once peak current of inductor over trans-conductance output level, the N-MOS turns off, the flip-flop resets, and external schottky diode turns on. This forces the current through the inductor to ramp back down, transferring the energy stored in the magnetic field to the output capacitor and load. To reduce external component amount, the device will be built-in internal loop compensation.

Enable Control

Digital logic of EN provides an electrical ON/OFF control of the power supply. Connecting this pin to ground or to any voltage less than 0.7V will completely turn OFF the regulator. In this state, current drain from the input supply is less than 1 μ A, the internal reference, error amplifier, comparators, and biasing circuitry turn off.

EN works as a simple on/off control. Drive EN high to enable the device, or drive EN low for shutdown.

Soft-Start

Soft-start allows a gradual increase of the internal current-limit level for the step-up converter during power-up to reduce input surge currents. As the internal current source charges the internal soft-start capacitor, the peak N-MOS current is limited by the voltage on the capacitor.

Cycle-by-Cycle Over-Current Protection

The AT1309 provides cycle-by-cycle over-current protection. Current limit is accomplished using a separate dedicated comparator. The cycle-by-cycle current limit abbreviates the on-time of the N-MOS in event that the current of flowing N-MOS is greater than the current limit value. The current-limit feature protection against a hard short or over-current fault at the output.

Thermal-Overload Protection

Thermal-overload protection limits total power dissipation in the AT1309. When the junction temperature exceeds $T_j=130$, a thermal sensor activates the thermal protection, which shuts down the IC, allowing the IC to cool. Once the device cools down by 10, IC will automatically recover normal operation. For continuous operation, do not exceed the absolute maximum junction-temperature rating of $T_j=120$.

Power dissipation consideration

The AT1309 maximum power dissipation depends on the thermal resistance of the IC package and circuit board, the temperature difference between the die junction and ambient air, and the rate of any airflow. The power dissipation in the device depends on the operating conditions of the regulator. In continuous condition, the step-up converter power dissipated internally across the internal N-MOS can be approximated by :

$$P_{boost} = \left[\left(\frac{I_O \times V_O}{V_{in}} \right)^2 + \frac{1}{12} \left(\frac{V_{in} \times D}{f_{OSC} \times L} \right)^2 \right] \times R_{DS(ON)} \times D$$

where

I_O : It is the load current.

f_{OSC} : It is a switching frequency.

Application Information

External components of boost converter can be designed by performing simple calculations.

Boost inductor

Inductor selection depends on input voltage, output voltage, maximum output current, switching frequency and availability of inductor values. The following boost circuit equations are useful in choosing the inductor values based on the application. They allow the trading of peak current and inductor value while allowing for consideration of component availability and cost.

The peak inductor current is given by:

$$I_{L_{peak}} = I_{L_{AVG}} + \frac{\Delta I_L}{2}$$

$$I_{L_{AVG}} = \frac{I_o}{1-D}$$

where:

ΔI_L is the inductor peak-to-peak current ripple and is decided by:

$$\Delta I_L = \frac{V_{in}}{L} \times \frac{D}{f_{OSC}}$$

D is the MOSFET turn on ratio and is decided by:

$$D = \frac{V_o - V_{in}}{V_o}$$

f_{OSC} is the switching frequency.

The inductor should be chosen to be able to handle this current and inductor saturation current rating should be greater than I_{PEAK} .

Diode selection

The output diode has average current of I_o , and peak current the same as the inductor's peak current and a voltage rating at least 1.5 times the output voltage. Schottky diode is recommended and it should be able to handle those current.

Output Capacitor

The AT1308 is specially compensated to be stable with capacitors which have a worst-case minimum value of 1uF at the particular V_{OUT} being set. Output ripple voltage requirements also determine the minimum value and type of capacitors. Output ripple voltage consists of two components the voltage drop caused by the switching current through the ESR of the output capacitor and the charging and discharging of the output capacitor:

$$V_{RIPPLE} = I_{L_{PEAK}} \times ESR + \frac{V_o - V_{in}}{V_o} \times \frac{I_o}{C_{OUT} \times f_{OSC}}$$

For low ESR ceramic capacitors, the output ripple is dominated by the charging or discharging of the output capacitor.

Impacting frequency stability of the overall control loop, Ceramic capacitors are preferred on the output capacitance, but tantalum capacitor may also suffice. If it use tantalum capacitor on the output terminal, that in addition the capacitance parallel with feedback resistor network is necessary. These frequency response effects together with the internal frequency compensation circuitry of AT1308 modify the gain and phase shift of the closed loop system.

PCB layout guidelines

Careful printed circuit layout is extremely important to avoid causing parasitical capacitance and line inductance. The following layout guidelines are recommended to achieve optimum performance.

- Please the boost converter diode and inductor close to the LX pin and no via. Keep traces short, direct, and wide.
- Please ceramic bypass capacitors near the input/output pin.
- Locate all feedback sense resistors as close to the feedback pins as possible.
- The ground connections of V_{IN} and V_{OUT} should be as close together as possible.

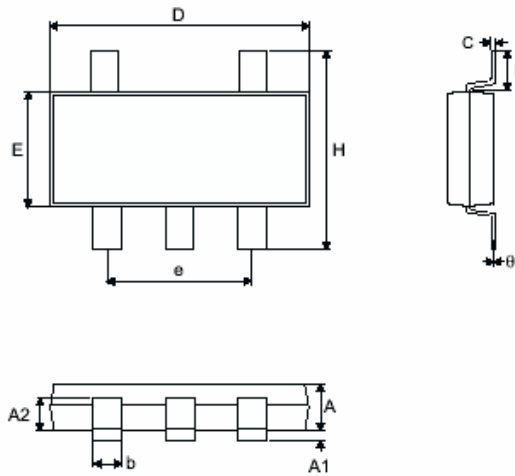
Small Outline SOT-25

Symbol	Dimensions in mm		
	Min.	Nom.	Max.
A	1.00	—	1.30
A1	—	—	0.10
A2	0.70	—	0.90
b	0.35	—	0.50
C	0.10	—	0.25
D	2.70	—	3.10
E	1.40	—	1.80
e	—	1.90	—
H	2.60	—	3
L	0.37	—	—
θ	1°	—	9°

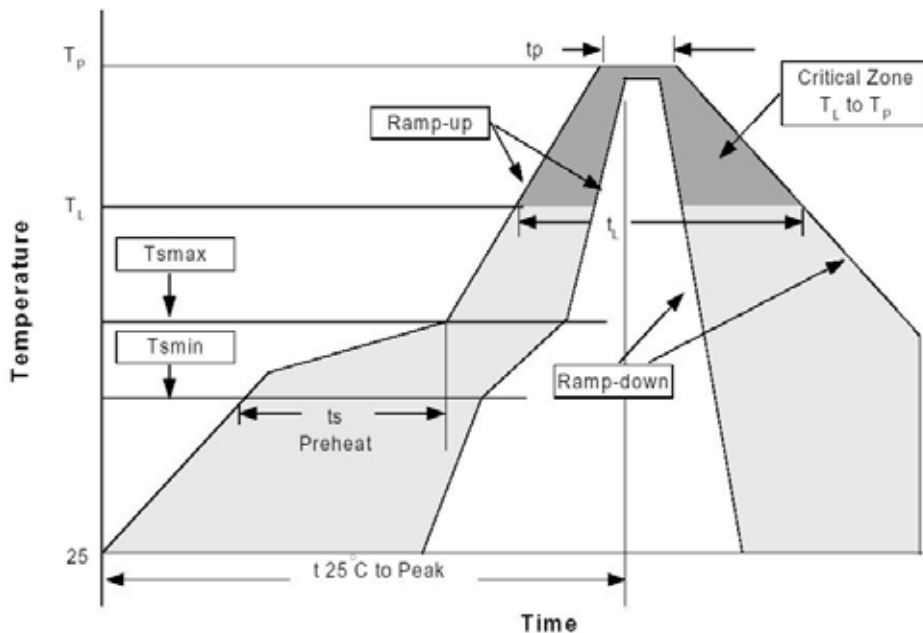
Reflow Profiles

Profile Feature	Sn-Pb Eutectic Assembly		Pb-Free Assembly	
	Large Body Pkg. thickness ≥2.5mm or Pkg. volume ≥350mm ³	Small Body Pkg. thickness <2.5mm or Pkg. volume <350mm ³	Large Body Pkg. thickness ≥2.5mm or Pkg. volume ≥350mm ³	Small Body Pkg. thickness ≥2.5mm or Pkg. volume ≥350mm ³
Average ramp-up rate (T _L to T _P)	3°C/second max.		3°C/second max.	
Preheat -Temperature Min(T _{smin}) -Temperature Max (T _{smax}) -Time (min to max)(t _s)	100°C 150°C 60-120 seconds		150°C 200°C 60-180 seconds	
T _{smax} to T _L -Ramp-up Rate			3°C/second max.	
Time maintained above: -Temperature (T _L) -Time (t _L)	183°C 60-150 seconds		217°C 60-150 seconds	
Peak Temperature(T _P)	225+0/-5°C	240+0/-5°C	245+0/-5°C	250+0/-5°C
Time within 5°C of actual Peak Temperature (t _p)	10-30 seconds	10-30 seconds	10-30 seconds	20-40 seconds
Ramp-down Rate	6°C/second max.		3°C/second max.	
Time 25°C to Peak Temperature	6 minutes max.		8 minutes max.	

*All temperatures refer to topside of the package, measured on the package body surface.