

Logic Diagram

## FEATURES:

- 80-Bit numeric processor
- RAD-PAK® radiation hardened against natural space radiation
- Total dose hardness:
  - > 100 krad (Si)
  - dependant upon space mission
- Single Event Effects:
  - SEU Threshold is ~ 3.38 MeV/mg/cm<sup>2</sup>
  - SEL Threshold = 37.1 - 59.9 MeV/mg/cm<sup>2</sup>
- Package: 68-pin RAD-PAK® quad flat pack
- Eight 80-bit numeric registers, usable as individual addressable general registers or as a register stack
- Data types include:
  - 32-, 64-, 80-bit floating point
  - 32-, 64-bit integers
  - 18-digit BCD operands
- 5 V Only power
- Built-in exception handling
- Upward object code compatible with All 80X87DX microprocessors
- Full-range transcendental operations for SINE, COSINE, TANGENT, ARCTANGENT and LOGARITHM

## DESCRIPTION:

Maxwell's 80387DX high speed microcircuit features a greater than 100 kilorad (Si) total dose tolerance. Using Maxwell's radiation hardened RAD-PAK® packaging technology, the 80387DX is a high-performance numerics processor that extends the 80386DX architecture with floating point, extended integer and BCD data types. The computing system fully conforms to the ANSI/IEEE floating-point standard. Using a numerics oriented architecture, the 80387DX adds over seventy mnemonics to the 80386DX instruction set, making the 80386DX/80387DX a complete solution for high-performance numerics processing.

Maxwell Technologies' patented RAD-PAK packaging technology incorporates radiation shielding in the microcircuit package. It eliminates the need for box shielding while providing the required radiation shielding for a lifetime in orbit or space mission. In a GEO orbit, RAD-PAK provides greater than 100 krad (Si) radiation dose tolerance. This product is available with screening up to Class S.

TABLE 1. PINOUT DESCRIPTION

PIN	SYMBOL	DESCRIPTION
1, 12, 19, 21, 35, 49, 53, 56	$V_{SS}$	Ground
2, 13, 20, 32, 36, 39, 52, 68	$V_{CC}$	Positive Power Supply
3-11, 18, 22-31, 33, 34, 37, 38, 40, 41, 64-67	D4-D12, D15, D16-25, D26, D27, D28, D29, D30, D31, D0-D3	Data Bus
42	CKM	Clock Mode
43	386CLK2	386 CPU Clock 2
44	387CLK2	387 MCP Clock 2
45	RESETIN	System Reset
46	NC	Not Connected
47 59	Tie High	Tie High
48	$\overline{\text{READY}}$	Bus Ready Input
50	$\overline{\text{CMD0}}$	Command
51	$\overline{\text{ADS}}$	Address Strobe
54	NPS2	MCP Select #2
55	$\overline{\text{NPS1}}$	MCP Select #1
57	$\overline{\text{W/R}}$	Write/Read
58	STEN	Status Enable
60	$\overline{\text{READYO}}$	Ready Output
61	$\overline{\text{BUSY}}$	Busy Status
62	$\overline{\text{ERROR}}$	Error Status
63	PEREQ	Processor Extension Request

TABLE 2. ABSOLUTE MAXIMUM RATINGS

PARAMETER	SYMBOL	MIN	MAX	UNIT
Voltage, any pin, with respect to Ground	$V_{CC}$	-0.5	$V_{CC}+0.5$	V
Power Dissipation	$P_D$	--	1.5	W
Storage Temperature Range	$T_S$	-65	150	°C
Operating Temperature Range	$T_A$	-55	125	°C
Lead Temperature (soldering 10 seconds)		--	260	°C

TABLE 3. DELTA LIMITS

PARAMETER	VARIATION
$I_{LI}$	$\pm 1.5 \mu\text{A}$
$I_{LO}$	$\pm 1.5 \mu\text{A}$
$I_{CC}$ CLK2 = 32 MHz	$\pm 25 \text{ mA}$
$I_{CC}$ CLK2 = 50 MHz	$\pm 39 \text{ mA}$

TABLE 4. RECOMMENDED OPERATING CONDITIONS

PARAMETER	SYMBOL	MIN	MAX	UNIT
Supply Voltage	$V_{CC}$	4.75	5.25	V
Input Low Voltage	$V_{IL}$	-0.3	0.8	V
Input High Voltage	$V_{IH}$	2.0	$V_{CC} + 0.3$	V
Operating Temperature	$T_A$	-55	125	$^{\circ}\text{C}$

TABLE 5. 80387DX DC ELECTRICAL CHARACTERISTICS

 $(V_{CC} = 4.75\text{V TO } 5.25\text{V}; T_A = -55 \text{ TO } +125^{\circ}\text{C}, \text{ UNLESS OTHERWISE SPECIFIED})$ 

PARAMETER	SYMBOL	TEST CONDITIONS	MIN	MAX	UNIT
Input Low Voltage	$V_{IL}^1$		--	0.8	V
Input High Voltage	$V_{IH}^1$		2.0	--	V
386 CLK2 Input Low Voltage	$V_{CL}$		--	0.8	V
386 CLK2 Input High Voltage	$V_{CH}$		3.7	--	V
Output Low Voltage	$V_{OL}$	$I_{OL} = 4 \text{ mA}$ , D0-D31, $I_{OL} = 2.5 \text{ mA}$ READYO, ERROR, BUSY, PEREQ	--	0.45	V
Output High Voltage	$V_{OH}$	$I_{OH} = -1 \text{ mA}$ , D0-D31, $I_{OH} = -0.6 \text{ mA}$ READYO, READYO, ERROR, BUSY, PEREQ	2.4	--	V
Input Leakage Current	$I_{LI}$	$0\text{V} \leq V_{IN} \leq V_{CC}$		$\pm 15$	$\mu\text{A}$
Output Leakage Current	$I_{LO}$	$0.45\text{V} \leq V_{OUT} \leq V_{CC}$	--	$\pm 15$	$\mu\text{A}$
Power Supply Current	$I_{CC}$	CLK2 = 32 MHz CLK2 = 40 MHz CLK2 = 50 MHz <sup>2</sup>	--	250 310 390	mA
Input Capacitance <sup>3</sup>	$C_{IN}$	$F_C = 1 \text{ MHz}$	--	10	pF
Output Capacitance <sup>3</sup>	$C_O$	$F_C = 1 \text{ MHz}$	--	12	pF
CLK2 Capacitance <sup>3</sup>	$C_{CLK}$	$F_C = 1 \text{ MHz}$	--	20	pF

1. This parameter is for all inputs, including 387CLK2 but excluding 386CLK2.
2.  $I_{CC}$  is measured at steady state, maximum capacitive loading on the outputs, and worst-case DC level at the inputs; 386CLK2 at the same frequency as 387CLK2.
3. Guaranteed By Design

TABLE 6. 80387DX COMBINATIONS OF BUS INTERFACE AND EXECUTION SPEEDS  
( $V_{CC} = 4.75V$  TO  $5.25V$ ;  $T_A = -55$  TO  $+125^\circ C$ , UNLESS OTHERWISE SPECIFIED)

PARAMETER	SYMBOL	TEST CONDITIONS	MIN	MAX	UNIT
Bus Interface Unit					MHz
-16			16	--	
-20			20	--	
-25			25	--	
Execution Unit					MHz
-16			16	--	
-20			20	--	
-25			25	--	

TABLE 7. 80387DX TIMING REQUIREMENTS OF THE EXECUTION UNIT  
( $V_{CC} = 4.75V$  TO  $5.25V$ ;  $T_A = -55$  TO  $+125^\circ C$ , UNLESS OTHERWISE SPECIFIED)

PARAMETER	SYMBOL	TEST CONDITION	MIN	MAX	UNIT
387CLK2 Period <sup>1</sup>	$t_1$	At 2V			ns
-16			31	125	
-20			25	125	
-25			20	125	
387CLK2 High Time	$t_{2a}$	At 2V			ns
-16			9	--	
-20			8	--	
-25			7	--	
387CLK2 High Time <sup>1</sup>	$t_{2b}$	At 3.7V			ns
-16			5	--	
-20			5	--	
-25			4	--	
387CLK2 Low Time	$t_{3a}$	At 2V			ns
-16			9	--	
-20			8	--	
-25			7	--	
387CLK2 Low Time <sup>1</sup>	$t_{3b}$	At 0.8V			ns
-16			7	--	
-20			6	--	
-25			5	--	
387CLK2 Fall Time <sup>1</sup>	$t_4$	At 3.7V to 0.8V			ns
-16			--	8	
-20			--	8	
-25			--	7	
387CLK2 Rise Time <sup>1</sup>	$t_5$	At 0.8V to 3.7V			ns
-16			--	8	
-20			--	8	
-25			--	7	

1. Guaranteed By Design

TABLE 8. 80387DX TIMING REQUIREMENTS OF THE BUS INTERFACE UNIT (OUTPUT TRIP LEVEL = 1.5V)  
 ( $V_{CC} = 4.75V$  TO  $5.25V$ ;  $T_A = -55$  TO  $+125^\circ C$ , UNLESS OTHERWISE SPECIFIED)

PARAMETER	CONDITIONS	SYMBOL	MIN	MAX	UNIT
386CLK2 Period <sup>1</sup> -16 -20 -25	At 2.0V	$t_1$	31 25 20	125 125 125	ns
386CLK2 High Time -16 -20 -25	At 2.0V	$t_{2a}$	9 8 7	-- -- --	ns
386CLK2 High Time1 -16 -20 -25	At 3.7V	$t_{2b}$	5 5 4	-- -- --	ns
386CLK2 Low Time -16 -20 -25	At 2V	$t_{3a}$	9 8 7	-- -- --	ns
386CLK2 Low Time <sup>1</sup> -16 -20 -25	At 0.8V	$t_{3b}$	7 6 5	-- -- --	ns
386CLK2 Fall Time <sup>1</sup> -16 -20 -25	At 3.7V to 0.8V	$t_4$	-- -- --	8 8 7	ns
386CLK2 Rise Time <sup>1</sup> -16 -20 -25	At 0.8V to 3.7V	$t_5$	-- -- --	8 8 7	ns
386 CLK2/387CLK2 Ratio		--	10/16	14/10	--
READYO Out Delay -16 -20 -25	$C_L = 50$ pF	$t_7$	4 3 3	34 31 24	ns
PEREQ, ERROR Out Delay -16 -20 -25	$C_L = 50$ pF	$t_7$	5 5 4	34 34 33	ns
BUSY Out Delay -16 -20 -25	$C_L = 50$ pF	$t_7$	5 5 4	34 29 29	ns

TABLE 8. 80387DX TIMING REQUIREMENTS OF THE BUS INTERFACE UNIT (OUTPUT TRIP LEVEL = 1.5V)  
 (V<sub>CC</sub> = 4.75V TO 5.25V; T<sub>A</sub> = -55 TO +125°C, UNLESS OTHERWISE SPECIFIED)

PARAMETER	CONDITIONS	SYMBOL	MIN	MAX	UNIT
D31 - D0 Out Delay -16 -20 -25	C <sub>L</sub> = 50 pF	t <sub>8</sub>	1 1 0	54 54 50	ns
D31 - D0 Setup Time		t <sub>10</sub>	11		ns
D31 - D0 Hold Delay		t <sub>11</sub>	11		ns
D31 - D0 Float Time -16 -20 -25	C <sub>L</sub> = 50 pF <sup>2</sup>	t <sub>12</sub>	6 6 5	33 27 24	ns
PEREQ, $\overline{\text{BUSY}}$ , $\overline{\text{ERROR}}$ , READYO Float Time <sup>1</sup> -16 -20 -25	C <sub>L</sub> = 50 pF <sup>1</sup>	t <sub>13</sub>	1 1 1	60 50 40	ns
ADS, $\overline{\text{WR}}$ Setup Time -16 -20 -25		t <sub>14</sub>	26 21 16	-- -- --	ns
ADS, $\overline{\text{WR}}$ Hold Time -16 -20 -25		t <sub>15</sub>	5 5 4	-- -- --	ns
READY Setup Time -16 -20 -25		t <sub>16</sub>	21 12 9	-- -- --	ns
READY Hold Time -16 -20 -25		t <sub>17</sub>	4 4 4	-- -- --	ns
CMDO Setup Time -16 -20 -25		t <sub>16</sub>	21 19 16	-- -- --	ns
CMDO Hold Time -16 -20 -25		t <sub>17</sub>	2 4 4	-- -- --	ns
NPS1, NPS2 Setup Time -16 -20 -25		t <sub>16</sub>	21 19 16	-- -- --	ns

TABLE 8. 80387DX TIMING REQUIREMENTS OF THE BUS INTERFACE UNIT (OUTPUT TRIP LEVEL = 1.5V)  
( $V_{CC} = 4.75V$  TO  $5.25V$ ;  $T_A = -55$  TO  $+125^\circ C$ , UNLESS OTHERWISE SPECIFIED)

PARAMETER	CONDITIONS	SYMBOL	MIN	MAX	UNIT
NPS1, NPS2 Hold Time -16 -20 -25		$t_{17}$	2 2 4	-- -- --	ns
STEN Setup Time -16 -20 -25		$t_{16}$	21 21 15	-- -- --	ns
STEN Hold Time -16 -20 -25		$t_{17}$	2 2 4	-- -- --	ns
RESETIN Setup Time -16 -20 -25		$t_{18}$	13 12 10	-- -- --	ns
RESETIN Hold Time -16 -20 -25		$t_{19}$	4 4 3	-- -- --	ns

1. Guaranteed By Design

2. Float condition occurs when maximum output current becomes less than  $I_{LO}$  in magnitude. Float Delay is not tested.

TABLE 9. 80387DX TIMING REQUIREMENT OF OTHER PARAMETER

PARAMETER	SYMBOL	MIN	MAX	UNIT
RESETIN Duration	$t_{30}$	40		(387 CLK2)
RESETIN Inactive to First Opcode Write	$t_{31}$	50		(387 CLK2)
BUSY Duration	$t_{32}$	6		(386 CLK2)
ERROR Inactive to BUSY Inactive	$t_{33}$	6		(386 CLK2)
PEREQ Inactive to ERROR Active	$t_{34}$	6		(386 CLK2)
READY Active to Busy Active	$t_{35}$	4	4	(386 CLK2)
READY Minimum Time from Opcode Write to Opcode to Opcode/ Operand Write	$t_{36}$	6		(386 CLK2)
READY Minimum Time from Operand Write to Operand Write	$t_{37}$	8		(386 CLK2)

FIGURE 1. TIMING DIAGRAMS - FAST TRANSITIONS TO AND FROM PIPELINED CYCLES

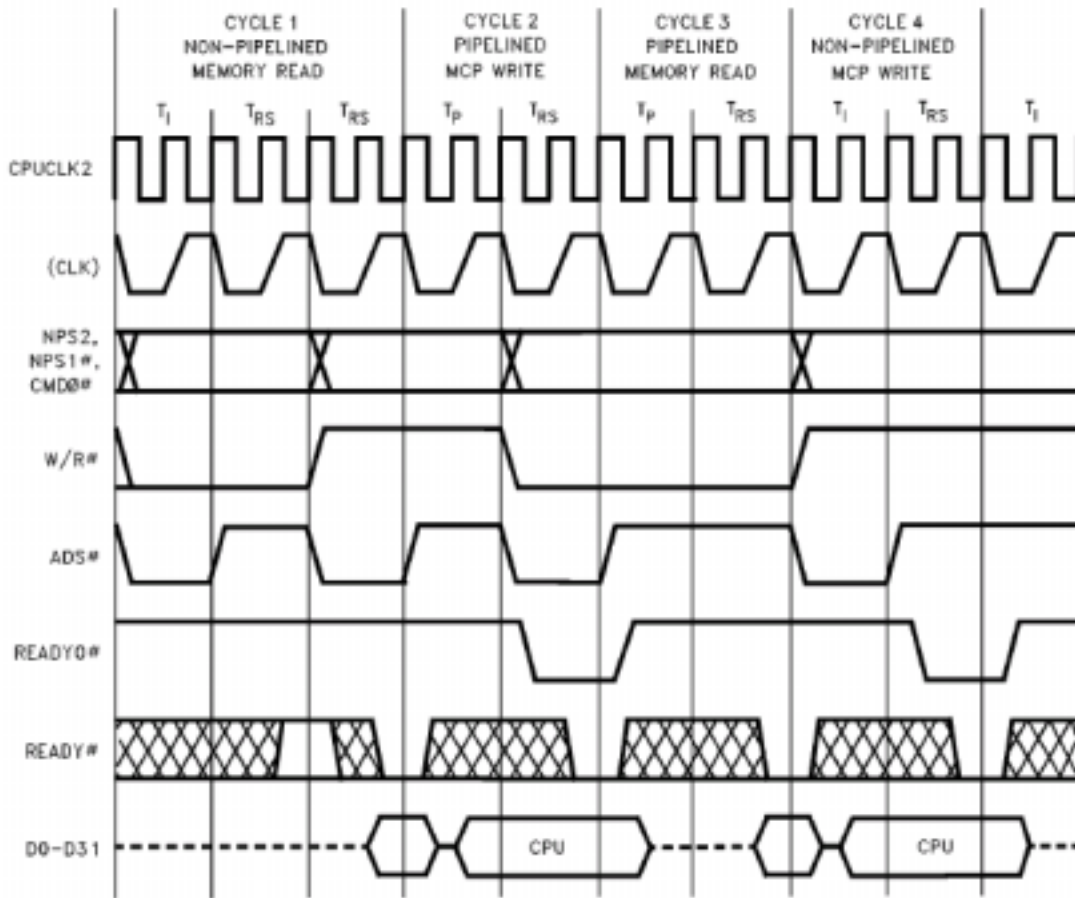
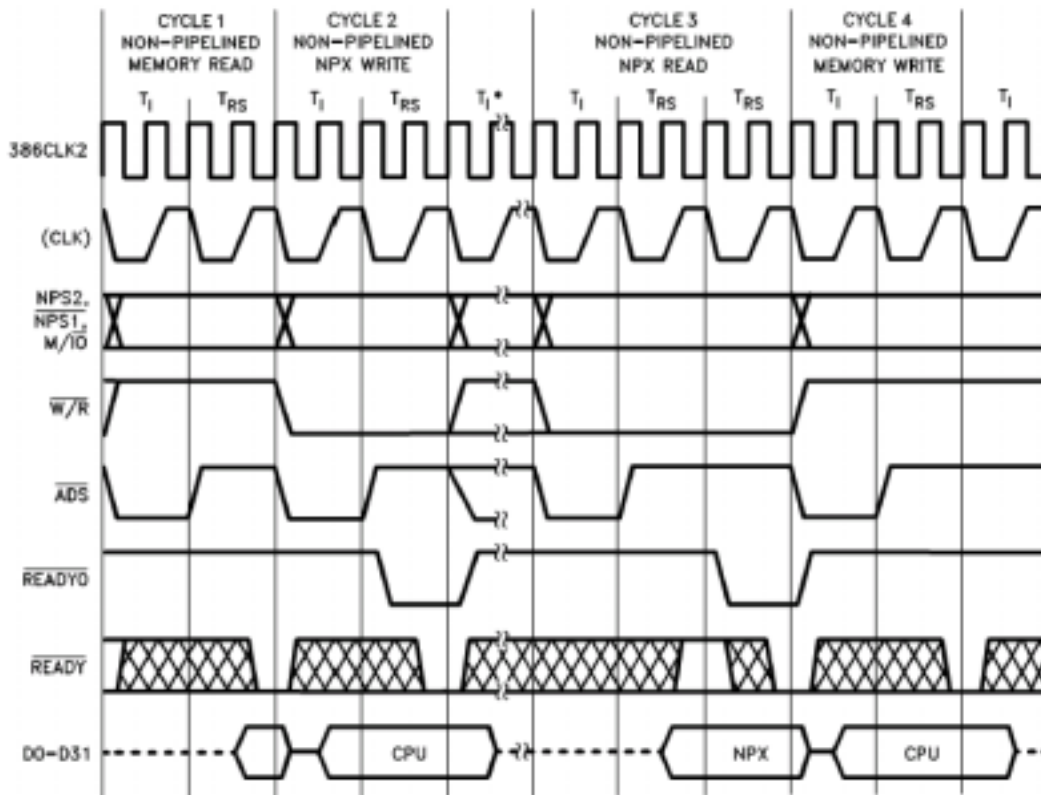
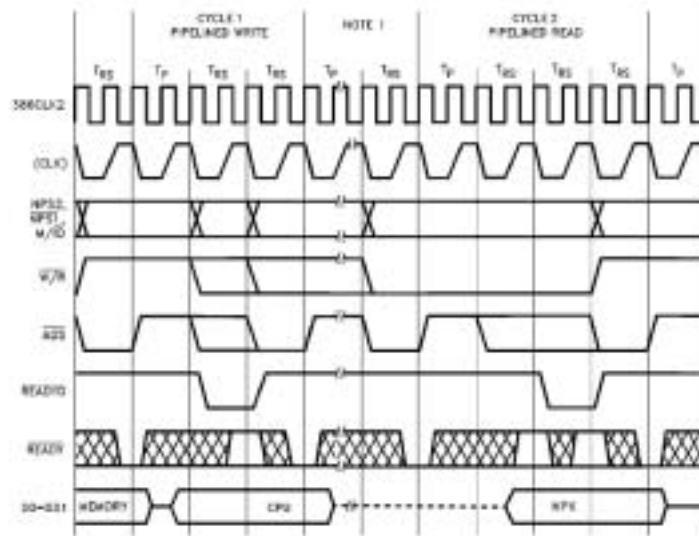

FIGURE 2. TIMING DIAGRAM – NON-PIPELINED READ AND WRITE CYCLES



Cycles 1 & 2 represent part of the operand transfer cycle for instructions involving either 4-byte or 8-byte operand loads.  
 Cycles 3 & 4 represent part of the operand transfer cycle for a store operation.  
 \*Cycles 1 & 2 could repeat here or  $T_1$  states for various non-operand transfer cycles and overhead.

FIGURE 3. TIMING DIAGRAM – PIPELINED CYCLES WITH WAIT STATES



**NOTE:**  
1. Cycles between operand write to the NPX and storing result.

FIGURE 4. TIMING DIAGRAM – STEN, BUSY, AND PEREQ TIMING RELATIONSHIP

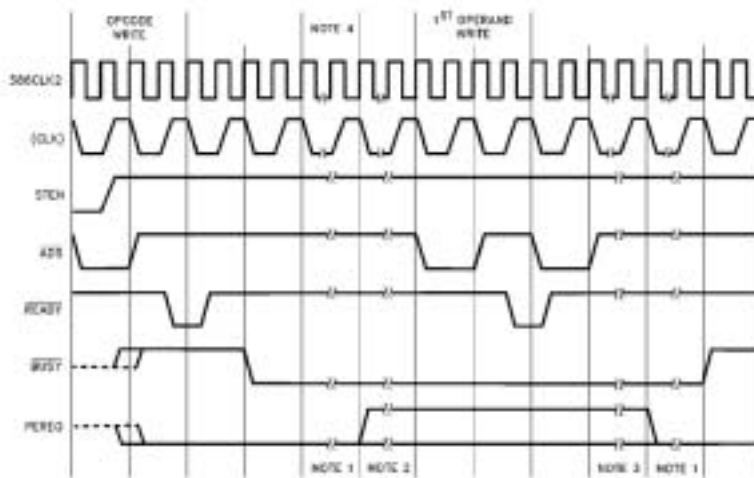

**NOTES:**  
1. Instruction dependent.  
2. PEREQ is an asynchronous input to the 387 processor; it may not be asserted (instruction dependent).  
3. More operand transfers.  
4. Memory read (operand) cycle is not shown.

FIGURE 5. TIMING DIAGRAM – 386CLK2/387CLK2 WAVEFORM AND MEASUREMENT POINTS FOR INPUT/OUTPUT AC SPECIFICATIONS

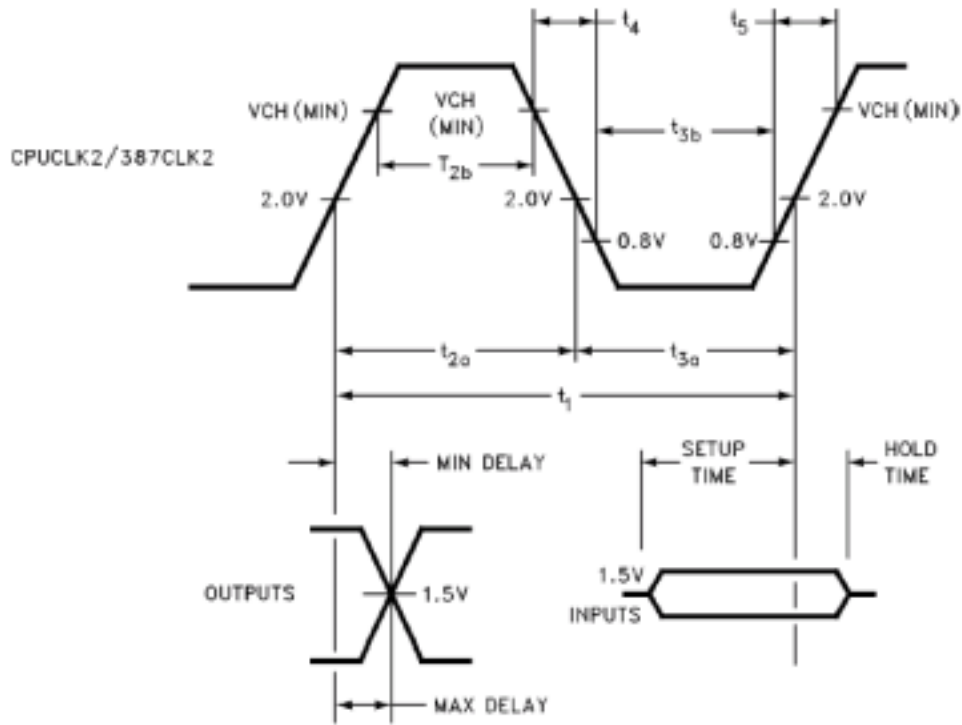

FIGURE 6. TIMING DIAGRAM – TEST CIRCUIT

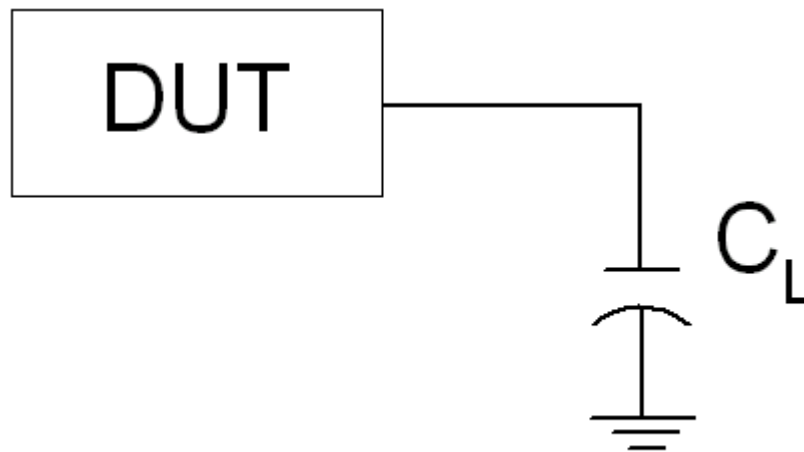
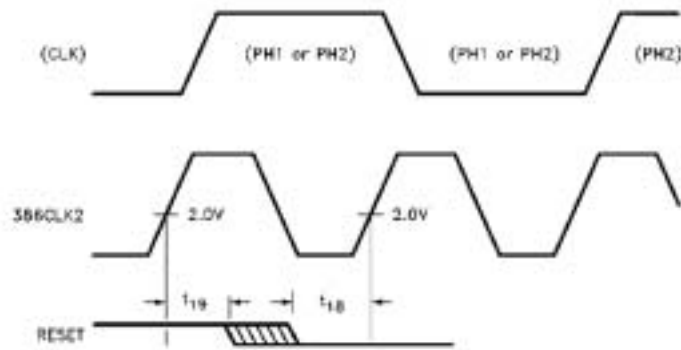
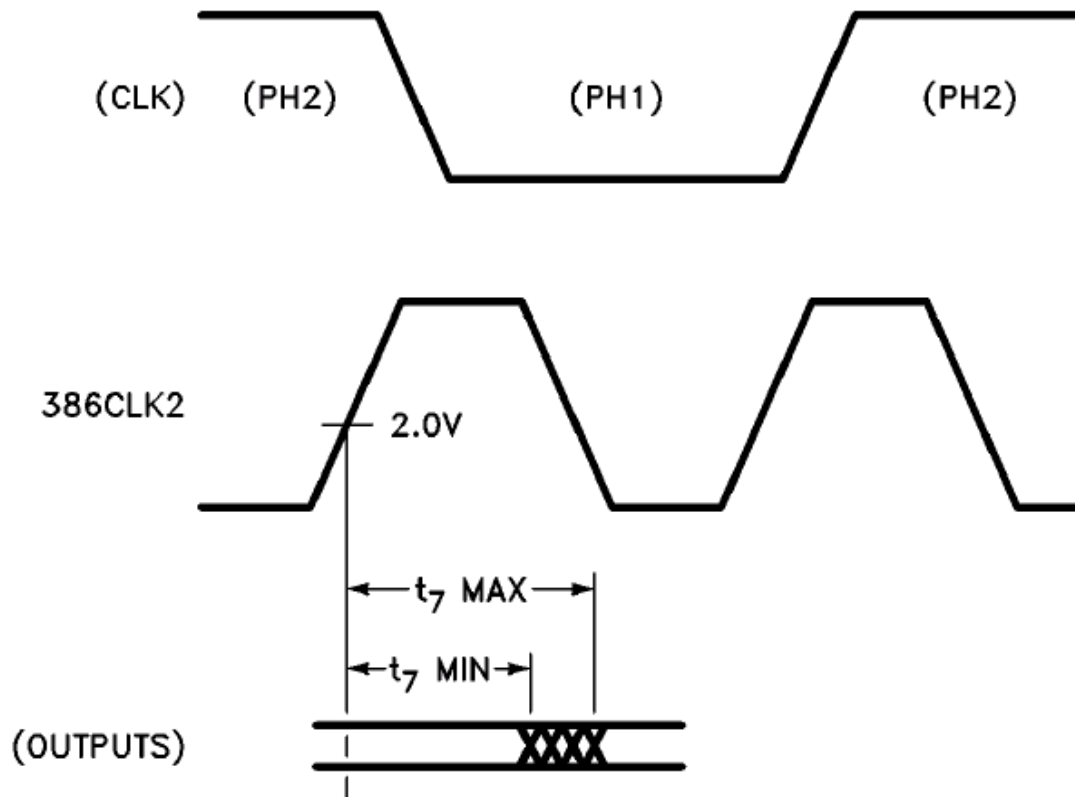

FIGURE 7. TIMING DIAGRAM – RESET



NOTE: The second internal processor phase following RESET high to low transition is PH2.

FIGURE 8. TIMING DIAGRAM – OUTPUT



(ERROR REFERENCED TO 387CLK2)

FIGURE 9. TIMING DIAGRAM – INPUT AND I/O SIGNALS

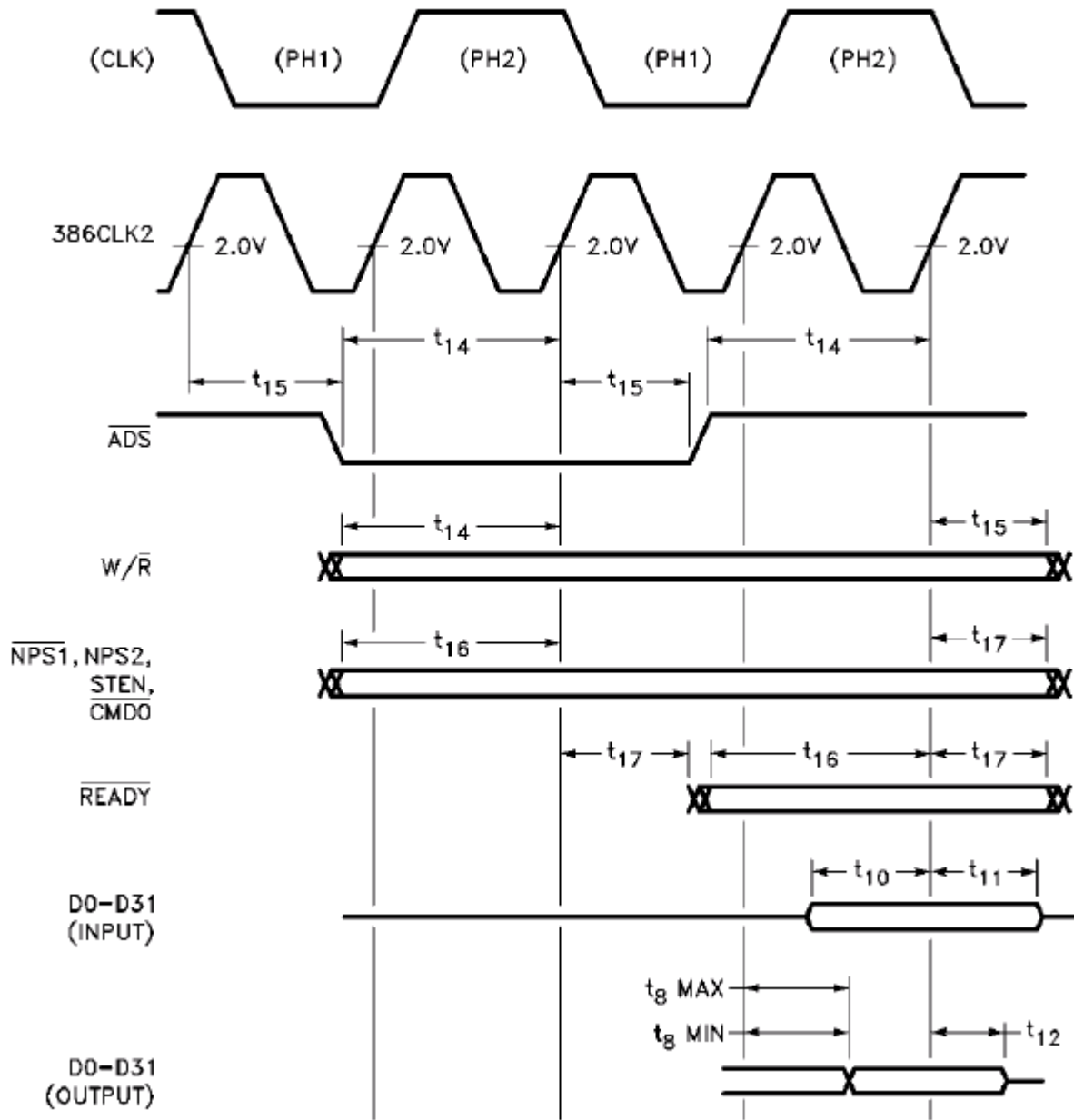

FIGURE 10. TIMING DIAGRAM – FLOAT FROM STEN

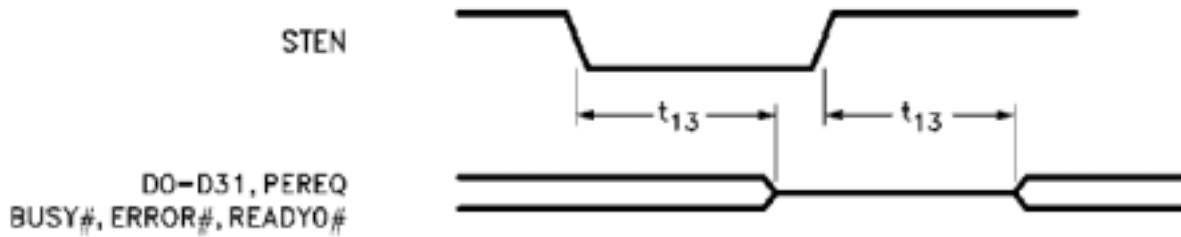
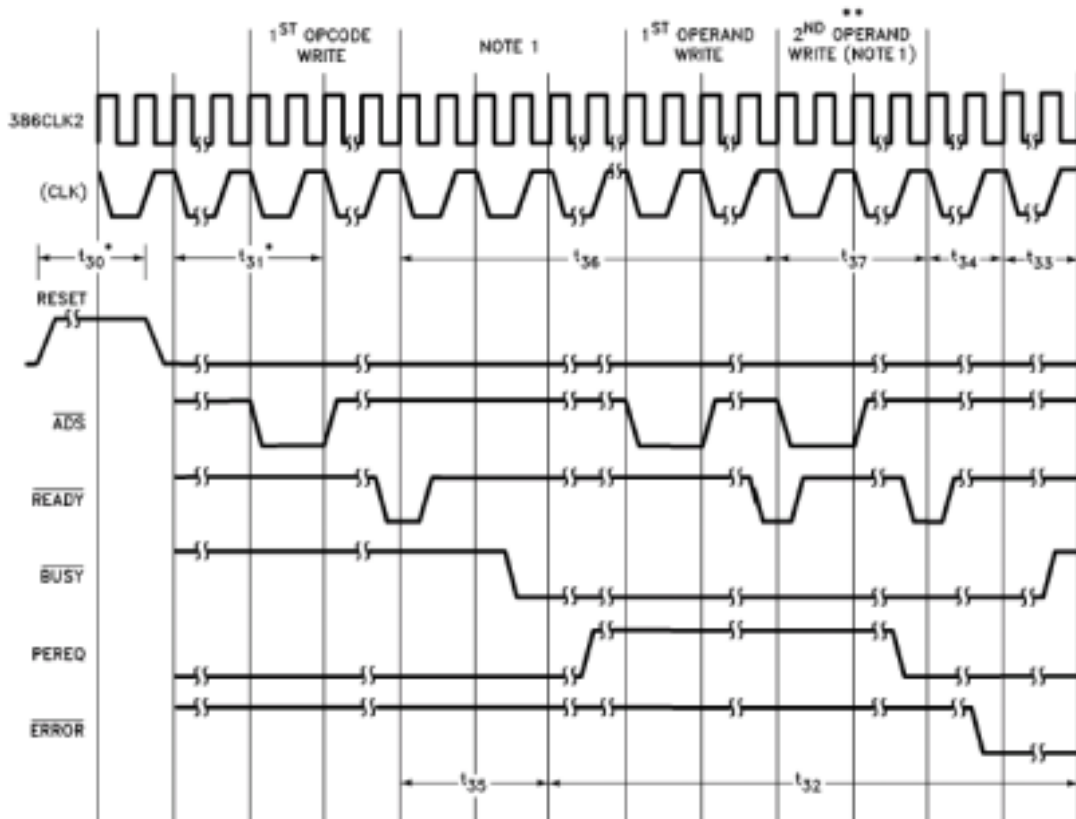
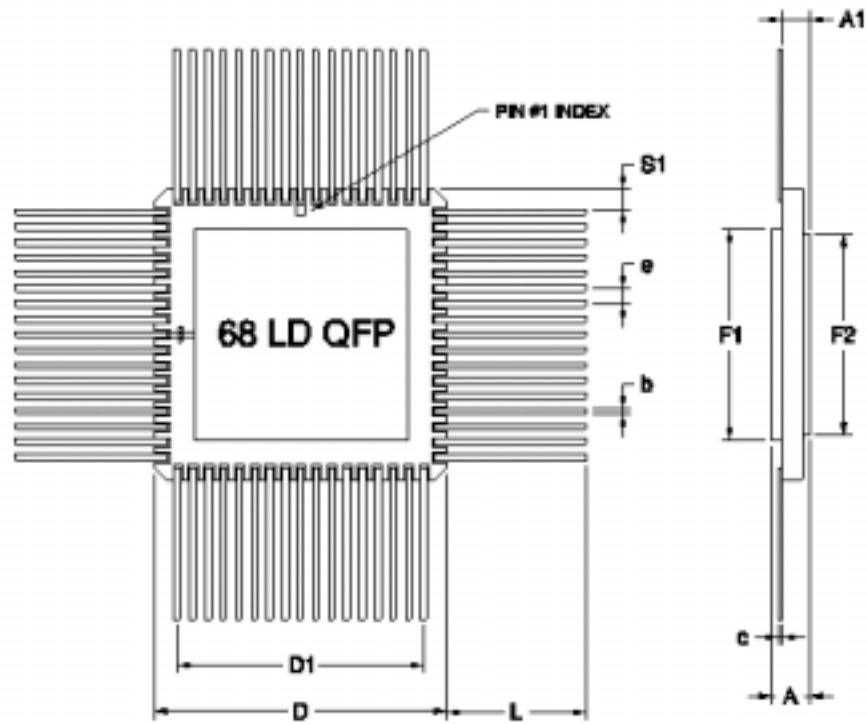

FIGURE 11. TIMING DIAGRAM – OTHER PARAMETERS



\* In 387CLK2's  
 \*\* or last operand

**NOTE:**  
 1. Memory read (operand) cycle is not shown.



14 PIN RAD-PAK® FLAT PACKAGE

SYMBOL	DIMENSION		
	MIN	NOM	MAX
A	0.121	0.135	0.145
b	0.016	0.018	0.020
c	0.008	0.010	0.012
D	0.940	0.950	0.960
D1	0.800 BSC		
e	0.050 BSC		
S1	0.013	0.066	--
F1	0.645	0.650	0.655
F2	0.645	0.650	0.655
L	0.477	0.487	0.497
A1	0.080	0.090	0.100
N	68		

Note: All dimensions in inches.  
Q68-01

## Important Notice:

These data sheets are created using the chip manufacturer's published specifications. Maxwell Technologies verifies functionality by testing key parameters either by 100% testing, sample testing or characterization.

The specifications presented within these data sheets represent the latest and most accurate information available to date. However, these specifications are subject to change without notice and Maxwell Technologies assumes no responsibility for the use of this information.

Maxwell Technologies' products are not authorized for use as critical components in life support devices or systems without express written approval from Maxwell Technologies.

Any claim against Maxwell Technologies must be made within 90 days from the date of shipment from Maxwell Technologies. Maxwell Technologies' liability shall be limited to replacement of defective parts.

## Product Ordering Options

