

MONOLITHIC QUAD H-BRIDGE DRIVER CIRCUIT

DESCRIPTION

The μ PD168101 is monolithic quad H-bridge driver LSI which uses power MOSFETs in the output stages. By using the MOS process, this driver IC has substantially improved the voltage loss of the output stage and power consumption as compared with conventional driver circuits using bipolar transistors.

By eliminating the charge pump circuit, the current during power-OFF is drastically decreased.

In addition, a low-voltage malfunction prevention circuit is also provided that prevents the IC from malfunctioning when the supply voltage drops.

As the package, a 24-pin plastic TSSOP is adopted to enable the creation of compact, slim application sets.

This driver IC can drive two stepping motor at the same time, and is ideal for driving stepping motors in the lens of a camera. It is the best for lens drive drivers, such as a digital camera and a video camera. Moreover, since the input of two terminals is respectively owned to H bridge 1 circuit, a maximum of four loads, such as DC motor, can be driven simultaneously.

FEATURES

- Four H bridge circuits employing power MOSFETs
- Low current consumption by eliminating charge pump
 - V_M pin current when power-OFF: 10 μ A MAX. V_{DD} pin current: 10 μ A MAX.
- Input logic frequency: 100 kHz
- 3-V power supply
 - Minimum operating supply voltage: 2.5 V
- Low voltage malfunction prevention circuit
- 24-pin plastic TSSOP (5.72 mm (225))

ORDERING INFORMATION

Part Number	Package
μ PD168101MA-6A5	24-pin plastic TSSOP (5.72 mm (225))

The information in this document is subject to change without notice. Before using this document, please confirm that this is the latest version.
Not all devices/types available in every country. Please check with local NEC representative for availability and additional information.

ABSOLUTE MAXIMUM RATINGS (T_A = 25°C)

When mounted on a glass epoxy board (10 cm × 10 cm × 1 mm, 15% copper foil)

Parameter	Symbol	Condition	Rating	Unit
Control block supply voltage	V _{DD}		-0.5 to +6.0	V
	V _M		-0.5 to +6.0	V
Input voltage	V _{IN}		-0.5 to V _{DD} + 0.5	V
Output terminal voltage	V _{OUT}		6.2	V
Output current	I _{M(DC)}	DC	±0.35	A/ch
	I _{M(pulse)}	PW ≤ 10 ms, Duty ≤ 5%	±0.7	A/ch
Power consumption	P _T		0.7	W
Peak junction temperature	T _{CH(MAX)}		150	°C
Storage temperature range	T _{stg}		-55 to +150	°C

RECOMMENDED OPERATING CONDITIONS

When mounted on a glass epoxy board (10 cm × 10 cm × 1 mm, 15% copper foil)

Parameter	Symbol	Condition	MIN.	TYP.	MAX.	Unit
Control block supply voltage	V _{DD}		2.5		5.5	V
	V _M		2.7		5.5	V
Output current	I _{M(DC)}	DC	-0.25		+0.25	A
Operating frequency	f _{IN}	IN terminal			100	kHz
Operating temperature range	T _A		-10		85	°C
Peak junction temperature	T _{CH(MAX)}				125	°C

CHARACTERISTICS (Unless otherwise specified, $V_{DD} = V_M = 3\text{ V}$, $T_A = 25^\circ\text{C}$)

Parameter	Symbol	Condition	MIN.	TYP.	MAX.	Unit
Off state V_M pin current	$I_{M(OFF)}$	All control terminal = 0 V Per V_M terminal			10	μA
V_{DD} terminal current at the time of standby	$I_{DD(ST)}$	All control terminal = 0 V			10	μA
V_{DD} terminal current at the time of operation	I_{DD}				1	mA
High level input current	I_{IH}	$V_{IN} = V_{DD}$			0.06	mA
Low level input current	I_{IL}	$V_{IN} = 0\text{ V}$	-1.0			μA
Input pull down resistance	R_{IND}		50		200	kΩ
High level input voltage	V_{IH}	$2.5\text{ V} \leq V_{DD} \leq 5.5\text{ V}$	$0.7 \times V_{DD}$		$V_{DD}+0.3$	V
Low level input voltage	V_{IL}	$2.5\text{ V} \leq V_{DD} \leq 5.5\text{ V}$	-0.3		$0.3 \times V_{DD}$	V
H-bridge ON resistance	R_{ON}	$2.7\text{ V} \leq V_M = V_{DD} \leq 5.5\text{ V}$ $I_M = 0.25\text{ A}$, Upper + lower		0.7	1.1	Ω
Low voltage malfunction prevention circuit operating voltage	V_{DDS1}	$V_M = 5\text{ V}$, $-10^\circ\text{C} \leq T_A \leq +85^\circ\text{C}$	0.8		2.5	V
	V_{DDS2}	$V_M = 3\text{ V}$, $-10^\circ\text{C} \leq T_A \leq +85^\circ\text{C}$	0.65		2.5	V
H bridge output turn-on time 1	t_{ON1}	$R_M = 20\ \Omega$, Figure 1 t_{ON1} : turn-on time from all control = 0 V t_{ON2} : turn-on time at operation		1.0		μs
H bridge output turn-on time 2	t_{ON2}			0.7	2.0	μs
H bridge output turn-off time	t_{OFF}			0.2	0.5	μs
H bridge output rise time	t_r			0.3	1.0	μs
H bridge output fall time	t_f			0.07	0.2	μs

- Remarks 1.** As for thermal shutdown circuit (TSD), junction temperature operates above 150°C . At the time of over thermal detection, current supply is stopped by making all output terminals into high impedance. In addition, thermal shutdown circuit does not operate at the time of standby.
- 2.** A low voltage malfunction operation prevention circuit operates, if a voltage power supply (V_{DD}) becomes less than 2.5 V. All output terminals be high impedance at the time of UVLO operation.

Figure 1. Switching time condition

(1) IN2 = Low-level

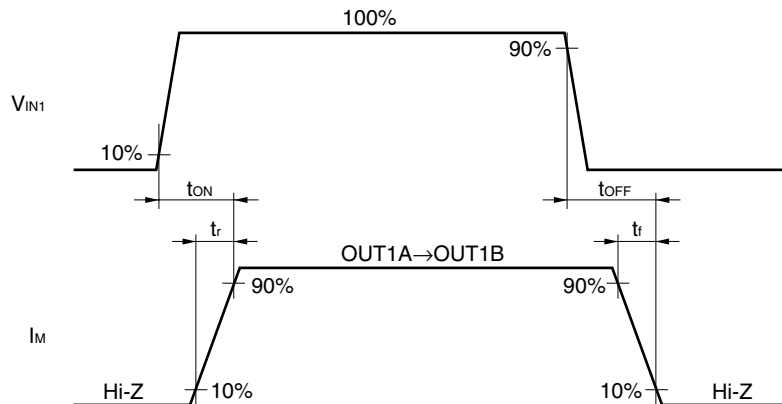

(2) IN2 = High-level

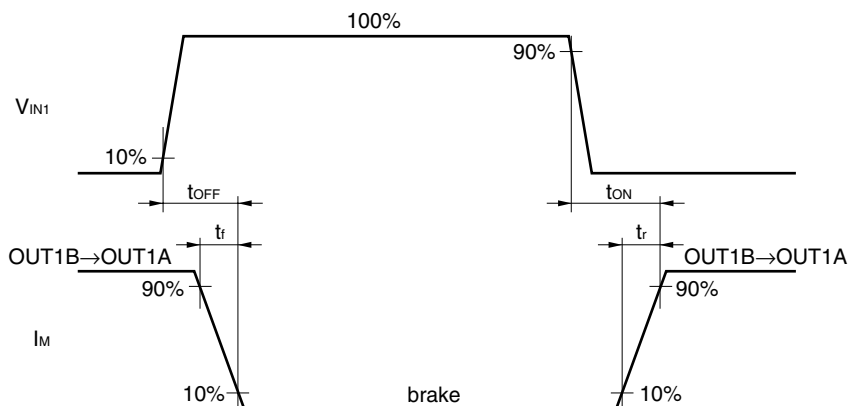

FUNCTION TABLE

The logic of each channel is as follows

Channel 1

IN1	IN2	OUT1A	OUT1B
L	L	Z	Z
L	H	L	H
H	L	H	L
H	H	L	L

Channel 2

IN3	IN4	OUT2A	OUT2B
L	L	Z	Z
L	H	L	H
H	L	H	L
H	H	L	L

Channel 3

IN5	IN6	OUT3A	OUT3B
L	L	Z	Z
L	H	L	H
H	L	H	L
H	H	L	L

Channel 4

IN7	IN8	OUT4A	OUT4B
L	L	Z	Z
L	H	L	H
H	L	H	L
H	H	L	L

H: High-level, L: Low-level, Z: High impedance

When all control pin is low-level, IC becomes stand-by state and current consumption is reduced.

PIN CONNECTION

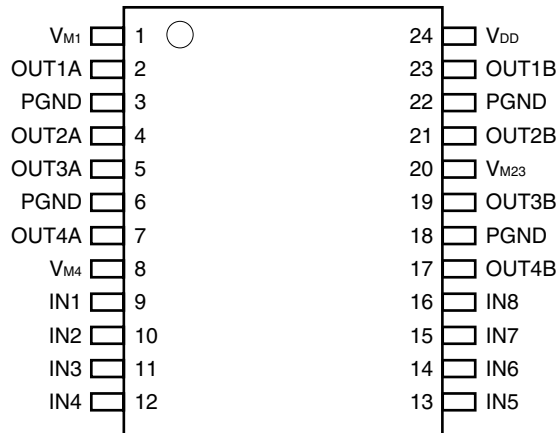

Pin No.	Pin name	Pin function
1	VM1	Output block supply voltage input terminal
2	OUT1A	Output terminal
3	PGND	Ground terminal
4	OUT2A	Output terminal
5	OUT3A	Output terminal
6	PGND	Ground terminal
7	OUT4A	Output terminal
8	VM4	Output block supply voltage input terminal
9	IN1	Control terminal (channel 1)
10	IN2	Control terminal (channel 1)
11	IN3	Control terminal (channel 2)
12	IN4	Control terminal (channel 2)
13	IN5	Control terminal (channel 3)
14	IN6	Control terminal (channel 3)
15	IN7	Control terminal (channel 4)
16	IN8	Control terminal (channel 4)
17	OUT4B	Output terminal
18	PGND	Ground terminal
19	OUT3B	Output terminal
20	VM23	Output block supply voltage input terminal
21	OUT2B	Output terminal
22	PGND	Ground terminal
23	OUT1B	Output terminal
24	VDD	Control block supply voltage input terminal

BLOCK DIAGRAM

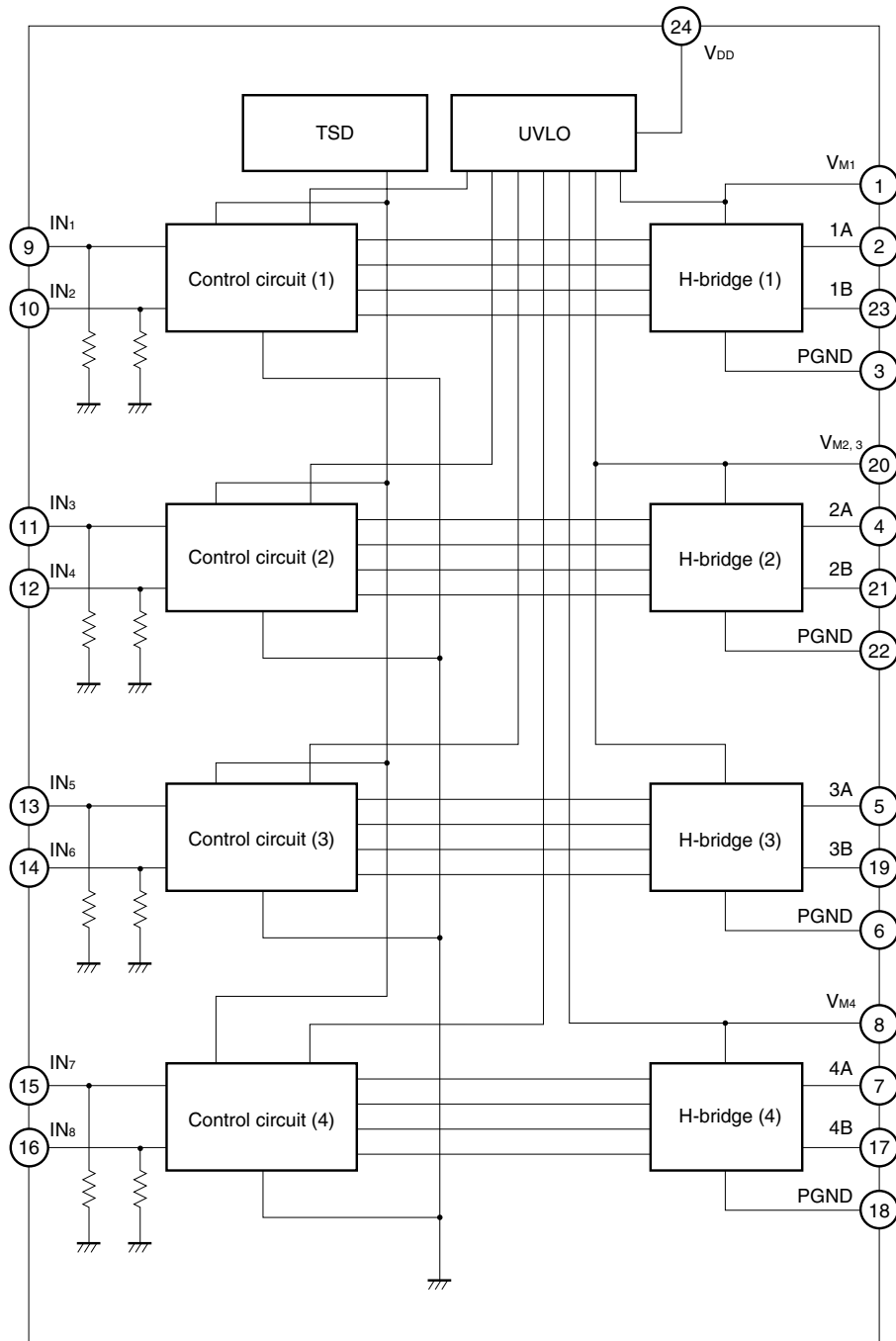

- Cautions**
1. The terminal which has more than one should connect not only one terminal but all terminals.
 2. Pull down resistance is connected to the input terminal. It's not necessary that the input terminal is connected when it isn't used.
 3. The motor part power supply terminals V_{M1} , $V_{M2,3}$, and V_{M4} are separated inside, and can impress an individually different power supply.
 4. The motor part power supply terminal of the output which is not used should impress voltage of recommended operation condition, or should connect to GND.
In addition, if voltage is impressed to V_M terminal even when an input is open, V_M terminal current (10 μA MAX) is flow at the time of standby.

TYPICAL CHARACTERISTICS

P_T vs. T_A characteristics

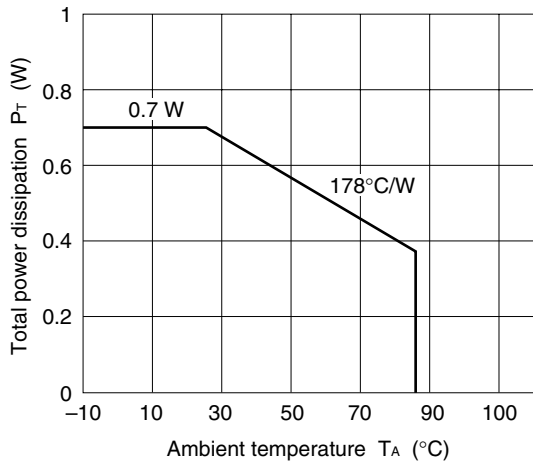

I_{DD} , $I_{DD(ST)}$ vs. V_{DD} characteristics

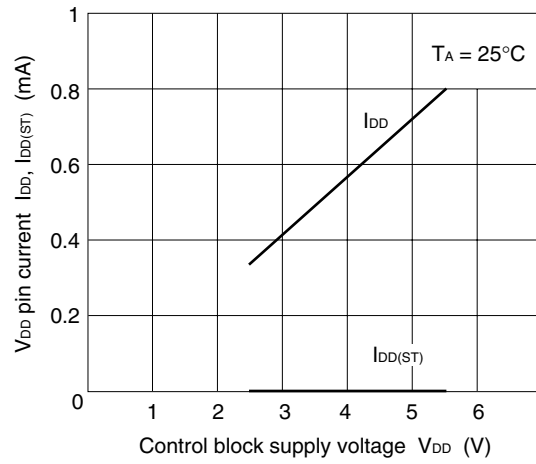

I_M vs. V_M characteristics

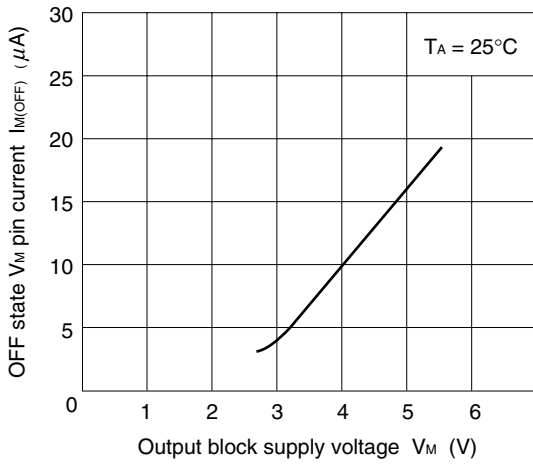

I_{IH} , I_{IL} vs. V_{DD} characteristics

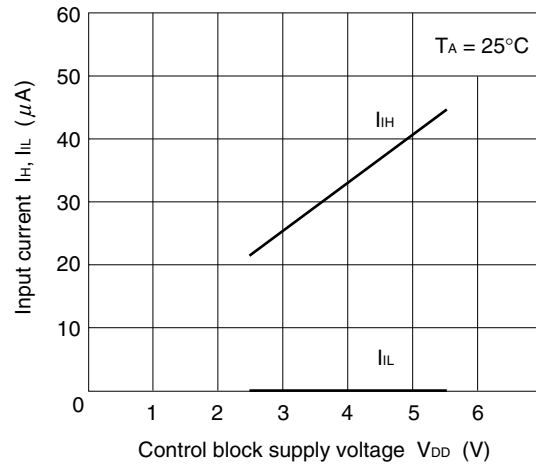

R_{IND} vs. V_{DD} characteristics

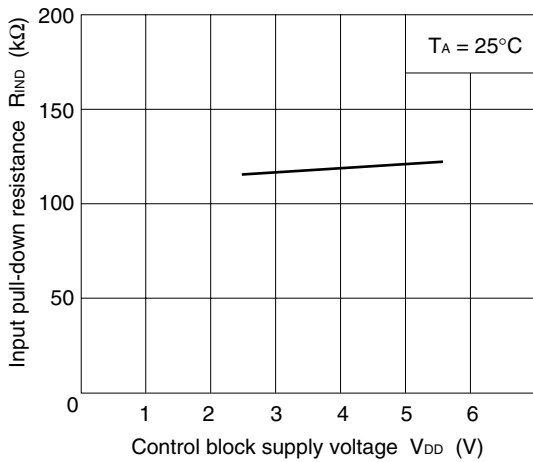

V_{IH} , V_{IL} vs. V_{DD} characteristics

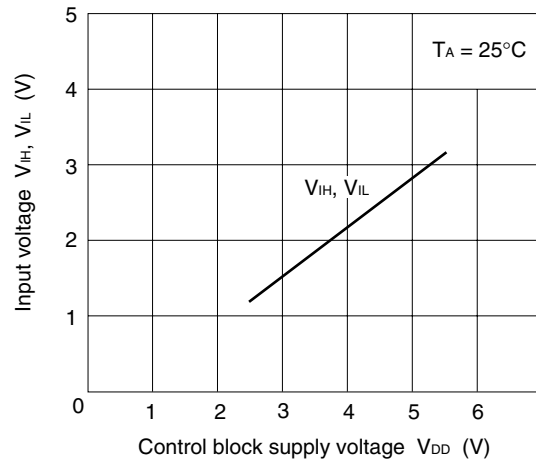

Detect voltage at low voltage characteristics

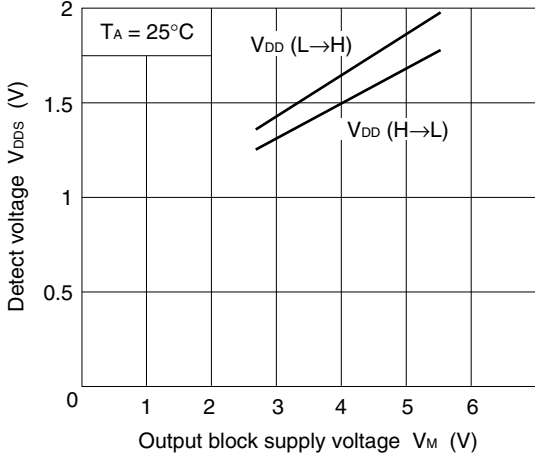

R_{ON} vs. V_M characteristics

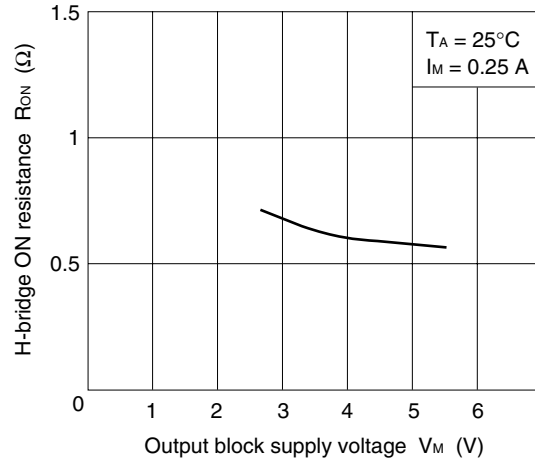

R_{ON} vs. T_A characteristics

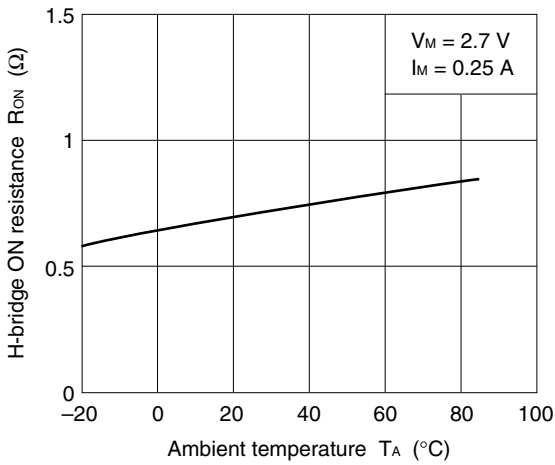

t_{ON1} , t_{ON2} , t_{OFF} vs. V_M characteristics

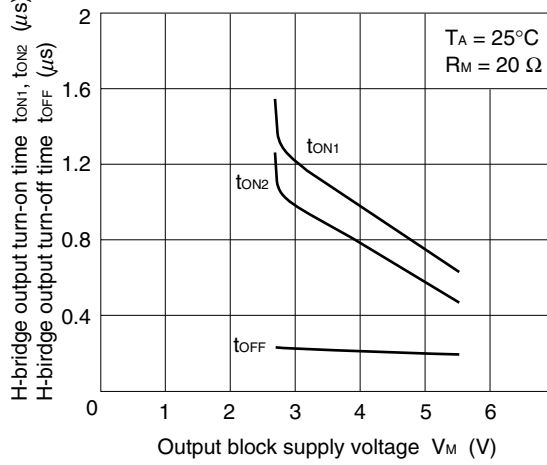

t_r , t_f vs. V_M characteristics

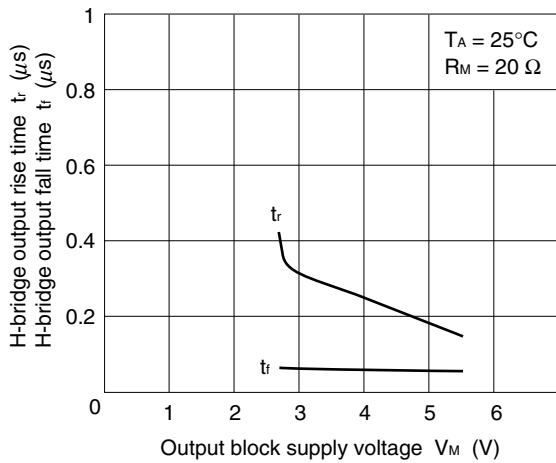

STANDARD CONNECTION EXAMPLE

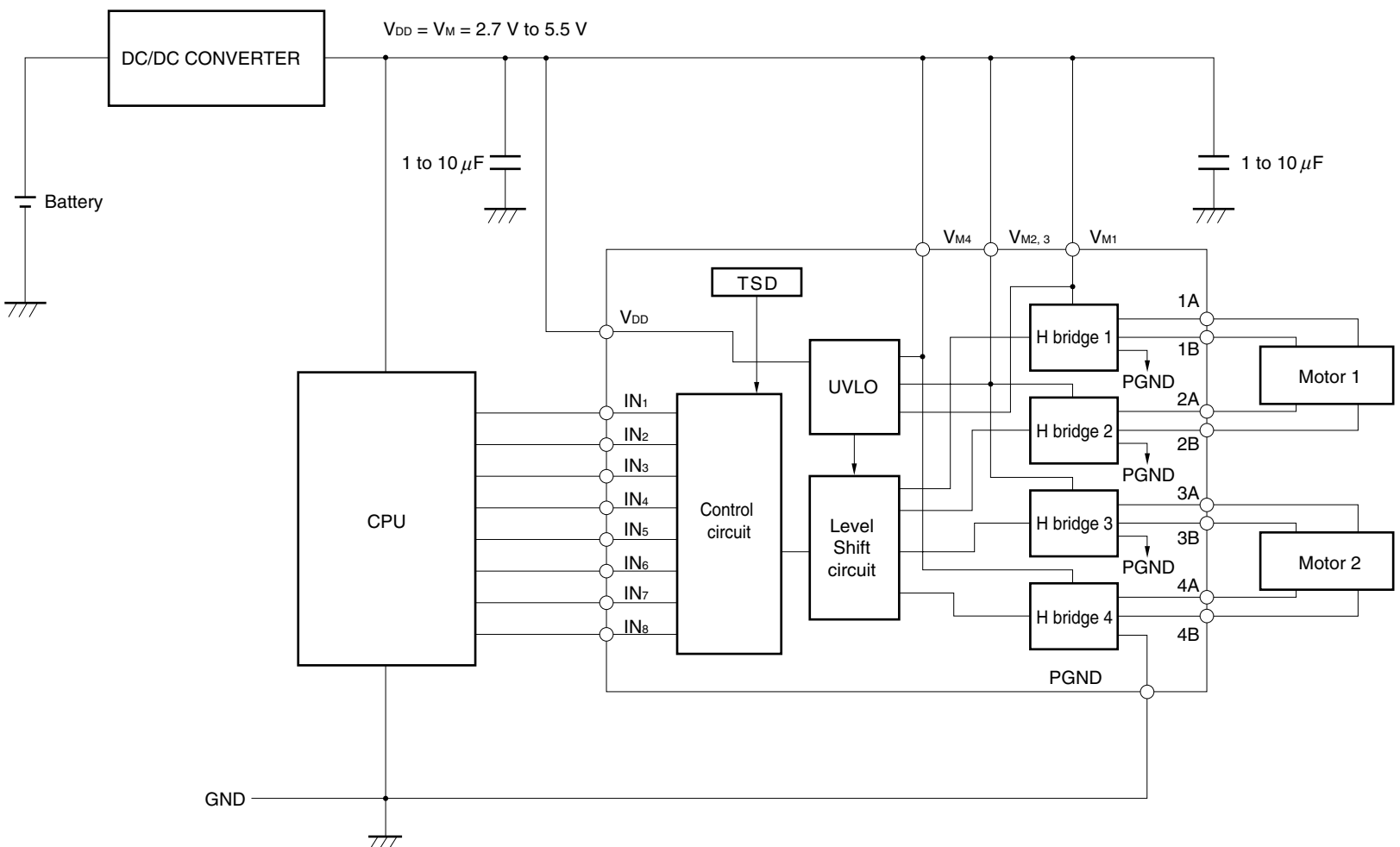

This circuit diagram is an example of connection, and is not a thing aiming at mass production.

PACKAGE DIMENSION

24-PIN PLASTIC TSSOP (5.72 mm (225))

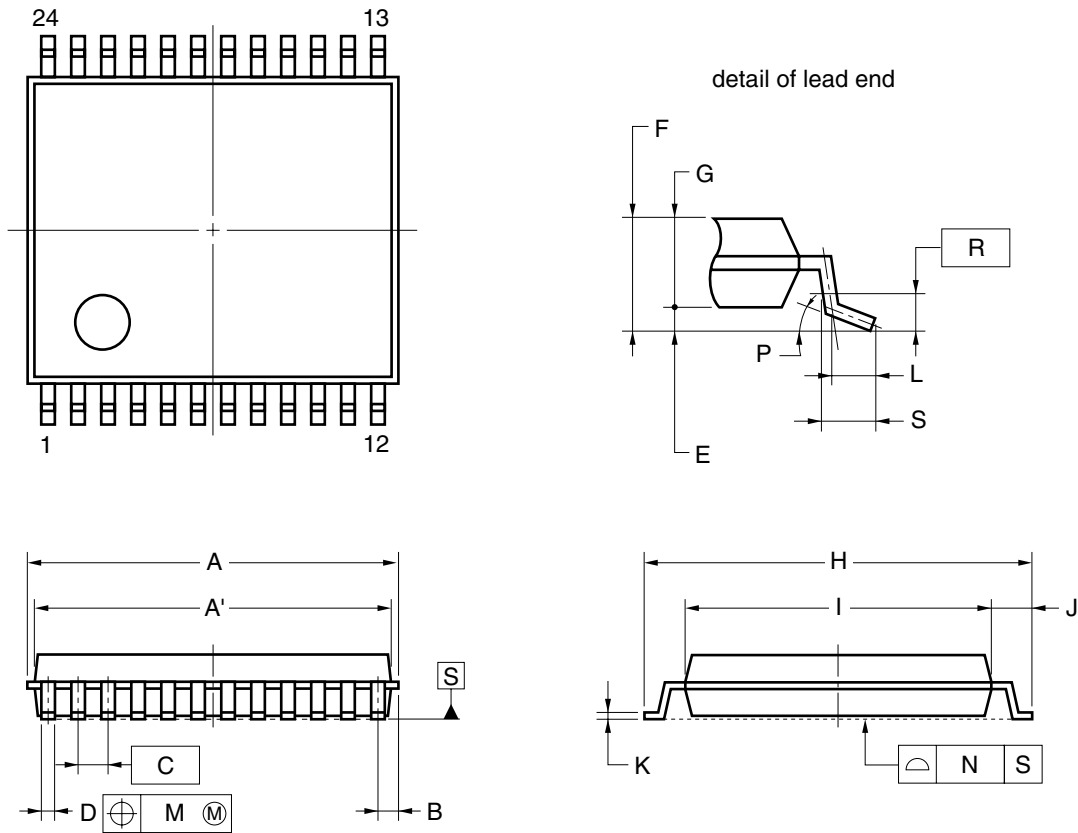

NOTE

Each lead centerline is located within 0.10 mm of its true position (T.P.) at maximum material condition.

ITEM	MILLIMETERS
A	6.65±0.10
A'	6.5±0.1
B	0.575
C	0.5 (T.P.)
D	0.22±0.05
E	0.1±0.05
F	1.2 MAX.
G	1.0±0.05
H	6.4±0.1
I	4.4±0.1
J	1.0±0.1
K	0.17±0.025
L	0.5
M	0.10
N	0.08
P	3°+5° -3°
R	0.25
S	0.6±0.15

P24MA-50-6A5

RECOMMENDED SOLDERING CONDITIONS

Solder this product under the following recommended conditions.

For soldering methods and conditions other than those recommended, consult NEC.

For details of the recommended soldering conditions, refer to information document “**Semiconductor Device Mounting Technology Manual**”.

Soldering Method	Soldering Conditions	Recommended Condition Symbol
Infrared reflow	Package peak temperature: 235°C; Time: 30 secs. max. (210°C min.); Number of times: 3 times max; Number of day: none; Flux: Rosin-based flux with little chlorine content (chlorine: 0.2Wt% max.) is recommended.	IR35-00-3
VPS	Package peak temperature: 215°C; Time: 40 secs. max. (200°C min.); Number of times: 3 times max.; Number of day: none; Flux: Rosin-based flux with little chlorine content (chlorine: 0.2 Wt% max.) is recommended.	VP15-00-3
Wave soldering	Package peak temperature: 260°C; Time: 10 secs. max.; Preheating temperature: 120°C max.; Number of times: once; Flux: Rosin-based flux with little chlorine content (chlorine: 0.2 Wt% max.) is recommended.	WS60-00-1

Caution Do not use two or more soldering methods in combination.

[MEMO]

[MEMO]

NOTES FOR CMOS DEVICES**① PRECAUTION AGAINST ESD FOR SEMICONDUCTORS**

Note:

Strong electric field, when exposed to a MOS device, can cause destruction of the gate oxide and ultimately degrade the device operation. Steps must be taken to stop generation of static electricity as much as possible, and quickly dissipate it once, when it has occurred. Environmental control must be adequate. When it is dry, humidifier should be used. It is recommended to avoid using insulators that easily build static electricity. Semiconductor devices must be stored and transported in an anti-static container, static shielding bag or conductive material. All test and measurement tools including work bench and floor should be grounded. The operator should be grounded using wrist strap. Semiconductor devices must not be touched with bare hands. Similar precautions need to be taken for PW boards with semiconductor devices on it.

② HANDLING OF UNUSED INPUT PINS FOR CMOS

Note:

No connection for CMOS device inputs can be cause of malfunction. If no connection is provided to the input pins, it is possible that an internal input level may be generated due to noise, etc., hence causing malfunction. CMOS devices behave differently than Bipolar or NMOS devices. Input levels of CMOS devices must be fixed high or low by using a pull-up or pull-down circuitry. Each unused pin should be connected to V_{DD} or GND with a resistor, if it is considered to have a possibility of being an output pin. All handling related to the unused pins must be judged device by device and related specifications governing the devices.

③ STATUS BEFORE INITIALIZATION OF MOS DEVICES

Note:

Power-on does not necessarily define initial status of MOS device. Production process of MOS does not define the initial operation status of the device. Immediately after the power source is turned ON, the devices with reset function have not yet been initialized. Hence, power-on does not guarantee out-pin levels, I/O settings or contents of registers. Device is not initialized until the reset signal is received. Reset operation must be executed immediately after power-on for devices having reset function.

Regional Information

Some information contained in this document may vary from country to country. Before using any NEC product in your application, please contact the NEC office in your country to obtain a list of authorized representatives and distributors. They will verify:

- Device availability
- Ordering information
- Product release schedule
- Availability of related technical literature
- Development environment specifications (for example, specifications for third-party tools and components, host computers, power plugs, AC supply voltages, and so forth)
- Network requirements

In addition, trademarks, registered trademarks, export restrictions, and other legal issues may also vary from country to country.

NEC Electronics Inc. (U.S.)

Santa Clara, California
Tel: 408-588-6000
800-366-9782
Fax: 408-588-6130
800-729-9288

NEC Electronics (Germany) GmbH

Duesseldorf, Germany
Tel: 0211-65 03 02
Fax: 0211-65 03 490

NEC Electronics (UK) Ltd.

Milton Keynes, UK
Tel: 01908-691-133
Fax: 01908-670-290

NEC Electronics Italiana s.r.l.

Milano, Italy
Tel: 02-66 75 41
Fax: 02-66 75 42 99

NEC Electronics (Germany) GmbH

Benelux Office
Eindhoven, The Netherlands
Tel: 040-2445845
Fax: 040-2444580

NEC Electronics (France) S.A.

Velizy-Villacoublay, France
Tel: 01-3067-5800
Fax: 01-3067-5899

NEC Electronics (France) S.A.

Madrid Office
Madrid, Spain
Tel: 091-504-2787
Fax: 091-504-2860

NEC Electronics (Germany) GmbH

Scandinavia Office
Taeby, Sweden
Tel: 08-63 80 820
Fax: 08-63 80 388

NEC Electronics Hong Kong Ltd.

Hong Kong
Tel: 2886-9318
Fax: 2886-9022/9044

NEC Electronics Hong Kong Ltd.

Seoul Branch
Seoul, Korea
Tel: 02-528-0303
Fax: 02-528-4411

NEC Electronics Singapore Pte. Ltd.

Novena Square, Singapore
Tel: 253-8311
Fax: 250-3583

NEC Electronics Taiwan Ltd.

Taipei, Taiwan
Tel: 02-2719-2377
Fax: 02-2719-5951

NEC do Brasil S.A.

Electron Devices Division
Guarulhos-SP, Brasil
Tel: 11-6462-6810
Fax: 11-6462-6829

J01.2

- **The information in this document is current as of March, 2001. The information is subject to change without notice. For actual design-in, refer to the latest publications of NEC's data sheets or data books, etc., for the most up-to-date specifications of NEC semiconductor products. Not all products and/or types are available in every country. Please check with an NEC sales representative for availability and additional information.**
- No part of this document may be copied or reproduced in any form or by any means without prior written consent of NEC. NEC assumes no responsibility for any errors that may appear in this document.
- NEC does not assume any liability for infringement of patents, copyrights or other intellectual property rights of third parties by or arising from the use of NEC semiconductor products listed in this document or any other liability arising from the use of such products. No license, express, implied or otherwise, is granted under any patents, copyrights or other intellectual property rights of NEC or others.
- Descriptions of circuits, software and other related information in this document are provided for illustrative purposes in semiconductor product operation and application examples. The incorporation of these circuits, software and information in the design of customer's equipment shall be done under the full responsibility of customer. NEC assumes no responsibility for any losses incurred by customers or third parties arising from the use of these circuits, software and information.
- While NEC endeavours to enhance the quality, reliability and safety of NEC semiconductor products, customers agree and acknowledge that the possibility of defects thereof cannot be eliminated entirely. To minimize risks of damage to property or injury (including death) to persons arising from defects in NEC semiconductor products, customers must incorporate sufficient safety measures in their design, such as redundancy, fire-containment, and anti-failure features.
- NEC semiconductor products are classified into the following three quality grades:
 - "Standard", "Special" and "Specific". The "Specific" quality grade applies only to semiconductor products developed based on a customer-designated "quality assurance program" for a specific application. The recommended applications of a semiconductor product depend on its quality grade, as indicated below. Customers must check the quality grade of each semiconductor product before using it in a particular application.
 - "Standard": Computers, office equipment, communications equipment, test and measurement equipment, audio and visual equipment, home electronic appliances, machine tools, personal electronic equipment and industrial robots
 - "Special": Transportation equipment (automobiles, trains, ships, etc.), traffic control systems, anti-disaster systems, anti-crime systems, safety equipment and medical equipment (not specifically designed for life support)
 - "Specific": Aircraft, aerospace equipment, submersible repeaters, nuclear reactor control systems, life support systems and medical equipment for life support, etc.

The quality grade of NEC semiconductor products is "Standard" unless otherwise expressly specified in NEC's data sheets or data books, etc. If customers wish to use NEC semiconductor products in applications not intended by NEC, they must contact an NEC sales representative in advance to determine NEC's willingness to support a given application.

(Note)

- (1) "NEC" as used in this statement means NEC Corporation and also includes its majority-owned subsidiaries.
- (2) "NEC semiconductor products" means any semiconductor product developed or manufactured by or for NEC (as defined above).