

General Description

The ZA3020 is a monolithic step down switch mode converter with a built in internal Power MOSFET. It achieves 2A continuous output current over a wide input supply range with excellent load and line regulation.

Current mode operation provides fast transient response and eases loop stabilization.

Fault condition protection includes cycle-by-cycle current limiting and thermal shutdown. In shutdown mode the regulator draws 23 μ A of supply current.

The ZA3020 requires a minimum number of readily available standard external components. A synchronization pin allows the part to be driven to 600KHz.

Ordering Information

Part Number *	Package	Temperature
ZA3020DS	SOIC8	-40 to +125 °C

. For Tape & Reel use suffix - Z (e.g. ZA3020DS-Z)

*

Features

- 2A Output Current
- 0.18 Ω Internal Power MOSFET Switch
- Stable with Low ESR Output Ceramic capacitors
- Up to 95% Efficiency
- 20 μ A Shutdown Mode
- Fixed 380kHz frequency
- Thermal Shutdown
- Cycle-by-cycle over current protection
- Wide 4.75 to 25V operating input range
- Output Adjustable from 1.22 to 21V
- Programmable under voltage lockout
- Frequency Synchronization Input
- Available in 8 pin SO package
- **Evaluation Board Available**

Applications

- Distributed Power Systems
- Battery Charger
- Pre-Regulator for Linear Regulators

Figure 1: Typical Application Circuit

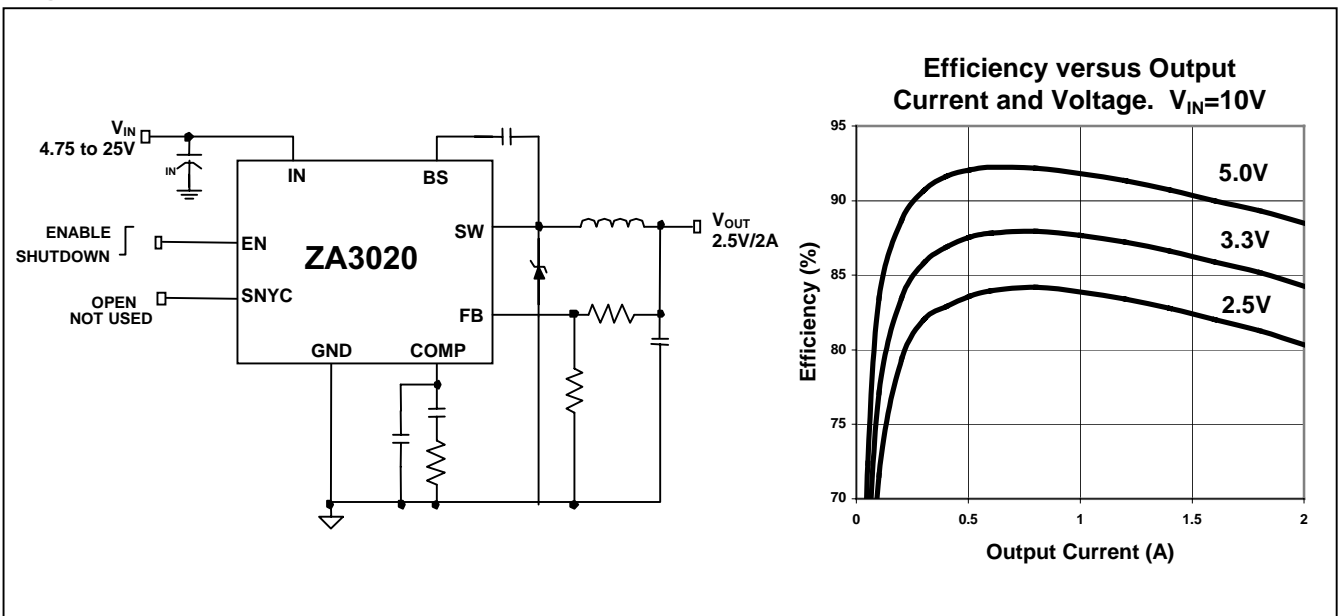

Absolute Maximum Ratings (Note 1)

Supply Voltage (V_{IN})	28V
Switch Voltage (V_{SW})	-1V to $V_{IN} + 1V$
Boost Voltage	$V_{SW} + 6V$
Feedback Voltage (V_{FB})	-0.3 to 6V
Enable/UVLO Voltage (V_{EN})	-0.3 to 6V
Comp Voltage (V_{COMP})	-0.3 to 6V
Sync Voltage (V_{SYNC})	-0.3 to 6V
Junction Temperature	150°C
Lead Temperature	260°C
Storage Temperature	-65 to +150°C

Recommended Operating Conditions (Note 2)

Input Voltage (V_{IN})	4.75V to 25V
Operating Temperature	-40 to +125°C

Package Thermal Characteristics

Thermal Resistance θ_{JA} (SOIC8)	105°C/W
--	---------

Electrical Characteristics (Unless otherwise specified $V_{IN}=12V$, $T_A=25$ C)

Parameters	Condition	Min	Typ	Max	Units
Feedback Voltage	$4.75V \leq V_{IN} \leq 25V$ $V_{COMP} < 2V$	1.198	1.222	1.246	V
Upper Switch On Resistance			0.18		Ω
Lower Switch On Resistance			10		Ω
Upper Switch Leakage	$V_{EN}=0V$; $V_{SW}=0V$		0	10	μA
Current Limit		2.4	2.85	3.3	A
Current Limit Gain. Output Current to Comp Pin Voltage			1.95		A/V
Error Amplifier Voltage Gain			400		V/V
Error Amplifier Transconductance	$\Delta I_C = \pm 10 \mu A$	500	770	1100	μMho
Oscillator Frequency		342	380	418	KHz
Short Circuit Frequency	$V_{FB} = 0V$	30	42	54	KHz
Sync Frequency	Sync Drive 0 to 2.7V	445		600	KHz
Maximum Duty Cycle	$V_{FB} = 1.0V$		90		%
Minimum Duty Cycle	$V_{FB} = 1.5V$			0	%
Enable Threshold	$I_{CC} > 100\mu A$	0.7	1.0	1.3	V
Enable Pull Up Current	$V_{EN} = 0V$	1.15	1.46	1.8	μA
Under Voltage Lockout Threshold High Going		2.37	2.495	2.62	V
Under Voltage Lockout Threshold Hysteresis			210		mV
Supply current (quiescent)	$V_{EN} \leq 0.4V$		23	36	μA
Supply current (operating)	$V_{EN} \geq 2.6V$; $V_{FB} = 1.4V$		1.0	1.2	mA
Thermal Shutdown			160		C

Note 1. Exceeding these ratings may damage the device.

Note 2. The device is not guaranteed to function outside its operating rating.

Note 3. Measured on approximately 1" square of 1 oz. copper surrounding device leads.

Figure 2: Functional Block Diagram

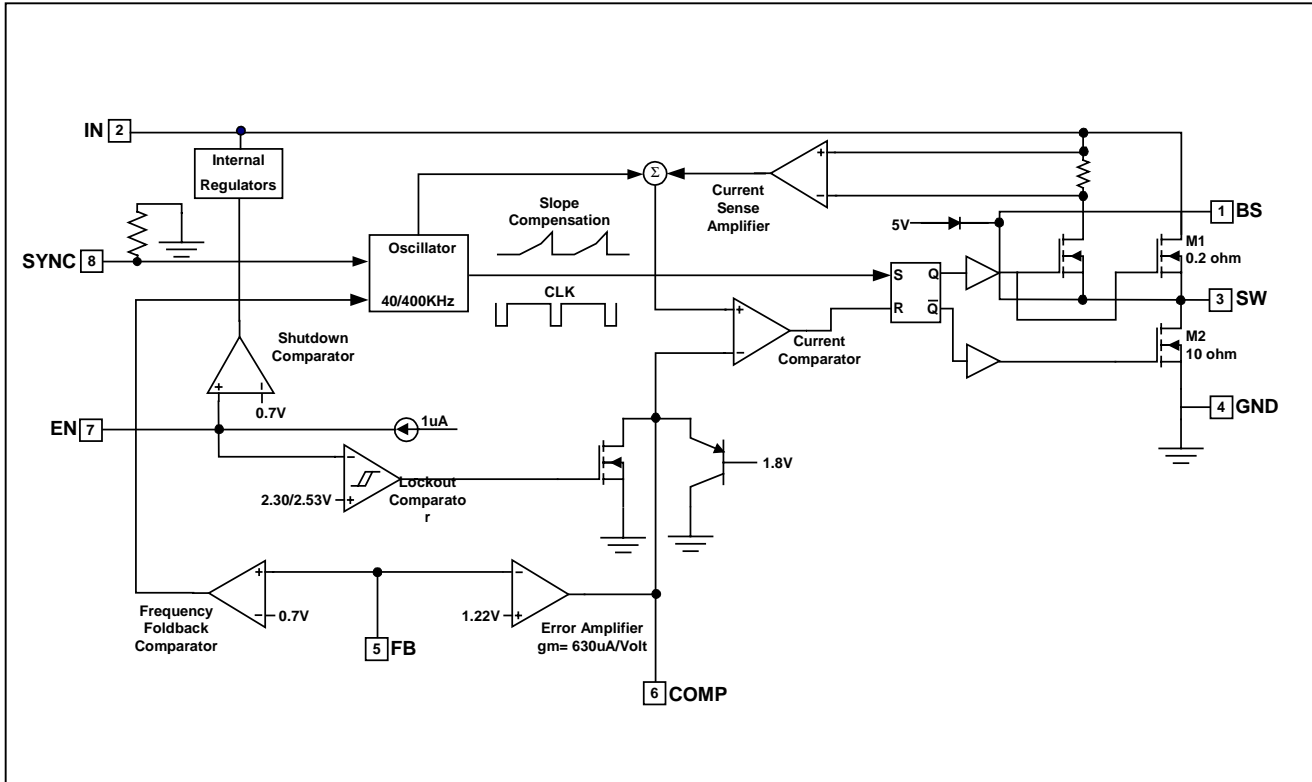

Functional Description

The ZA3020 is a current mode regulator. That is, the compensation pin voltage is proportional to the current delivered to the load.

At the beginning of a cycle: the upper transistor M1 is off; the lower transistor M2 on; the COMP pin voltage is higher than the current sense amplifier output; and the current comparator's output is low. The rising edge of the 380KHz CLK signal sets the RS Flip-Flop. Its output turns off M2 and turns on M1 thus connecting the Switch pin and inductor to the Input supply. The increasing inductor current is sensed and amplified by the Current Sense Amplifier. Ramp compensation is summed to Current Sense Amplifier output and compared to the error amplifier output by the Current Comparator. When the Current Sense Amplifier plus Slope Compensation signal exceeds the Comp pin voltage, the RS Flip-Flop is reset and the chip reverts to its initial M1 off, M2 on state.

If the Current Sense Amplifier plus Slope Compensation signal does not exceed the COMP voltage, then the falling edge of the CLK resets the Flip-Flop.

The output of the Error amplifier integrates the voltage difference between the feedback and the 1.22V bandgap reference. The polarity is such that feedback pin voltages lower than 1.22V increases the COMP pin voltage. Since the COMP pin's voltage is proportional to the peak inductor current an increase in its voltage increases current delivered to the output.

The lower 10Ω switch ensures that the bootstrap capacitor voltage is charged during light load conditions. External Schottky Diode D1 carries most of the inductor current.

Pin Descriptions

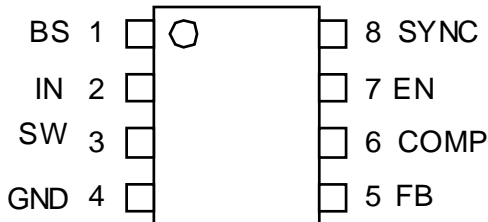

Pin 1: BS - Bootstrap - C5

This capacitor is needed to drive the power switch's gate above the supply voltage. It is connected between SW and Bootstrap pins to effect a floating supply across the power switch driver. The voltage across C5 is about 5V and is supplied by the internal +5V supply when the SW pin voltage is low.

Pin 2: IN - Supply Voltage

The ZA3020 operates from a +4.75V to +25V unregulated input. C1 is needed to prevent large voltage spikes from appearing at the input.

Pin 3: SW - Switch

This connects the inductor to either IN through M1 or to GND through M2.

Pin 4: GND - Ground

This pin is the voltage reference for the regulated voltage. For this reason care must be taken in its layout. This node should be placed outside of the D_{SCH} to C1 ground path to prevent switching current spikes to induce voltage noise into the part.

Pin 5: FB - Feedback

An external resistor divider from the output voltage to GND, tapped to the FB pin sets the output voltage. To prevent current limit run away during a short circuit fault condition the frequency fold back comparator lowers the oscillation frequency when the FB voltage is below 650mV.

Pin 6: COMP - Compensation

This node is the output of the transconductance error amplifier and the input to the current comparator. Frequency compensation is done at this node by connecting a series R-C to ground. See the compensation section for exact details.

Pin 7: EN - Enable/UVLO

A voltage greater than 2.495V enables operation. Leave the input unconnected if unused. An Under Voltage Lockout (UVLO) function can be implemented by the addition of a resistor divider from V_{IN} to GND. For complete low current shutdown its needs to be less than 0.7V.

Pin 8: SYNC - Synchronization Input

This pin is used to synchronize the internal oscillator frequency to an external source. There is an internal 11K Ω pull down resistor to GND hence leave the input unconnected if unused.

Sync Pin Operation

The SYNC pin driving waveform should be a square wave with a rise time of less than 20ns. Minimum Hi voltage level is 2.7V. Low level is less than 0.8V. The frequency of the external Sync signal needs to be greater than 445 KHz.

A rising edge on the SYNC pin forces a reset of the oscillator. The upper DMOS is switched off immediately if it is not already off. 250ns later the upper DMOS turns on connecting SW to V_{IN} .

Applications Information

Bootstrap Capacitor – C6

This bypasses the upper switch gate drive. Its value should be $\geq 4.7nF$. For simplicity of design this capacitor can be the same value as Compensation cap C3.

Compensation Capacitor – C3

This is the system compensation cap that is in series with R3. Using a ceramic 10nF, 50V, X7R capacitor allows it to match C5.

Auxiliary Compensation Capacitor – C6

This is the system compensation cap that connects between the COMP and GND pin. This capacitor rolls off the high frequency noise and gain that can cause duty cycle jitter. On well laid out boards using low ESR Output capacitor (C2) C6 may not be necessary. It $-3dB$ frequency is set by $1/\pi(R3 \times C6)$. For $R3=10K\Omega$ and $C6=100pF$ the cut-off frequency is 159KHz which filters out the 400KHz switching noise and yet is above the GBW target of 10KHz to 80KHz Use a ceramic 100pF, 50V, X7 capacitor.

Compensation Resistor – R3

The loop compensation gain is directly proportional to R3's value. The higher it's value the higher the gain. Calculation of its value is discussed in detail in the Loop Compensation section. Refer Table 4 for recommended values that accompany a surface mount ceramic and special polymer output capacitor.

Feedback Divider Resistors – R2, R1

The Output voltage is set by R2 and R3:

$$V_{OUT} = 1.22V [1 + (R2 / R1)]$$

The maximum recommended value of R1 is 100K Ω . Too high an impedance can make the Feedback node prone to noise injection particularly if unshielded inductors are used. 10K Ω is a good standard value.

Input Bypass Capacitor – C1

C1 is the bulk supply capacitor whose value should be $\geq 10\mu F$. The capacitor can be electrolytic, tantalum or ceramic. However since it absorbs the input switching current it requires an adequate ripple current rating. Its RMS current rating should be greater than approximately 1/2 of the output current.

For insuring stable operation C1 should be placed as close to the IC as possible. Alternately a smaller high quality ceramic 0.1 μF capacitor may be placed closer to the IC and the bulk C1 placed further away. However if using this technique some caution is needed if the bulk C1 is also a high quality ceramic capacitor. Large voltage excursions caused by resonant energy oscillation between the two is possible.

Schottky Catch Diode – D1

D1 supplies most of the current to inductor L1 when V_{SW} is low. The lower the forward Schottky voltage drop (V_{SCH}) the higher the regulator efficiency.

Tables 2 provides the Schottky part numbers based on the maximum input voltage and current rating. Table 3 lists manufacturer's websites.

D1's maximum reverse voltage rating should be greater than the maximum input voltage V_{IN} (Max).

The diode's average current rating must be above the average load current:

$$I_{DIODE} (AVG) = I_{LOAD} \times [V_{IN} - (V_{OUT} + V_{SCH})] / V_{IN}$$

Example:

$$V_{IN} = 12V, V_{OUT} = 3.3V, I_{LOAD} = 1.2A, V_{SCH} = 0.5V.$$

$$I_{DIODE} (AVG) = 1.2A \times [12 - (3.3 + 0.5)] / 12V \\ = 0.82A$$

In this case a 1A diode can be used.

Applications Information Continued

Table 2: Diode Selection Guide

V _{IN} (Max)	1A Diodes	2A Diodes
15V	10BQ15	30BQ15
20V	1N5817 B120 SS12	B220 SK23 SR22
30V	1N5818 B130 MBRS130 SS13	20BQ030 B230 SK23 SR23 SS23

Table 3: Schottky Diode Manufacturers

Vendor	Web Site
Diodes, Inc.	www.diodes.com
Fairchild Semiconductor	www.fairchildsemi.com
General Semiconductor	www.gensemi.com
International Rectifier	www.irf.com
On Semiconductor	www.onsemi.com
Pan Jit International	www.panjit.com.tw

Inductor – L1

Optimal inductor selection involves trade-offs in electrical value, current rating and mechanical sizing.

Table 4 lists the recommended minimum inductor values for common output voltage values. Table 5 Selection guide lists inductors by manufacturer, electrical value, maximum output current, DC resistance, core type, core material and mechanical sizing.

Table IV. Recommended components for standard output voltages

V _{OUT}	R2	L1 minimum
1.22V	0Ω	6.8μH
1.5V	2.32KΩ	6.8μH
1.8V	4.75KΩ	10μH
2.5V	10.5KΩ	10μH
3.3V	16.9KΩ	15μH
5.0V	30.9KΩ	22μH

The Maximum current rating of the inductor should be above the peak operating current:

$$I_{PEAK} = I_{LOAD} + \frac{(V_{OUT})(V_{IN}-V_{OUT})}{2(L)(F)(V_{IN})}$$

Example: V_{IN}=12V V_{OUT}=3.3V, L=15μH, I_{LOAD}=1.2A

$$I_{PEAK} = 1.6 + \frac{(3.3)(12-3.3)}{2(15\mu)(380KHz)(12)}$$

$$I_{PEAK} = 1.809A$$

Using Table 5 select a 15μH inductor with a Max I_{DC} rating of > 1.809A.

Output Capacitor - C2

The selection of the output capacitor is the most critical component of a switching regulator. Its electrical value and equivalent series resistance (ESR) directly affect:

- System stability
- Loop compensation components R3 and C3
- Output ripple voltage

Moreover C2 is frequently the most expensive component of a switching regulator.

Figures 3 and 4 along with Table 4 are schematics for two C2 components that have low ESR value.

Figure 3: ZA3020 with Murata 22 μ F / 10V Ceramic Output

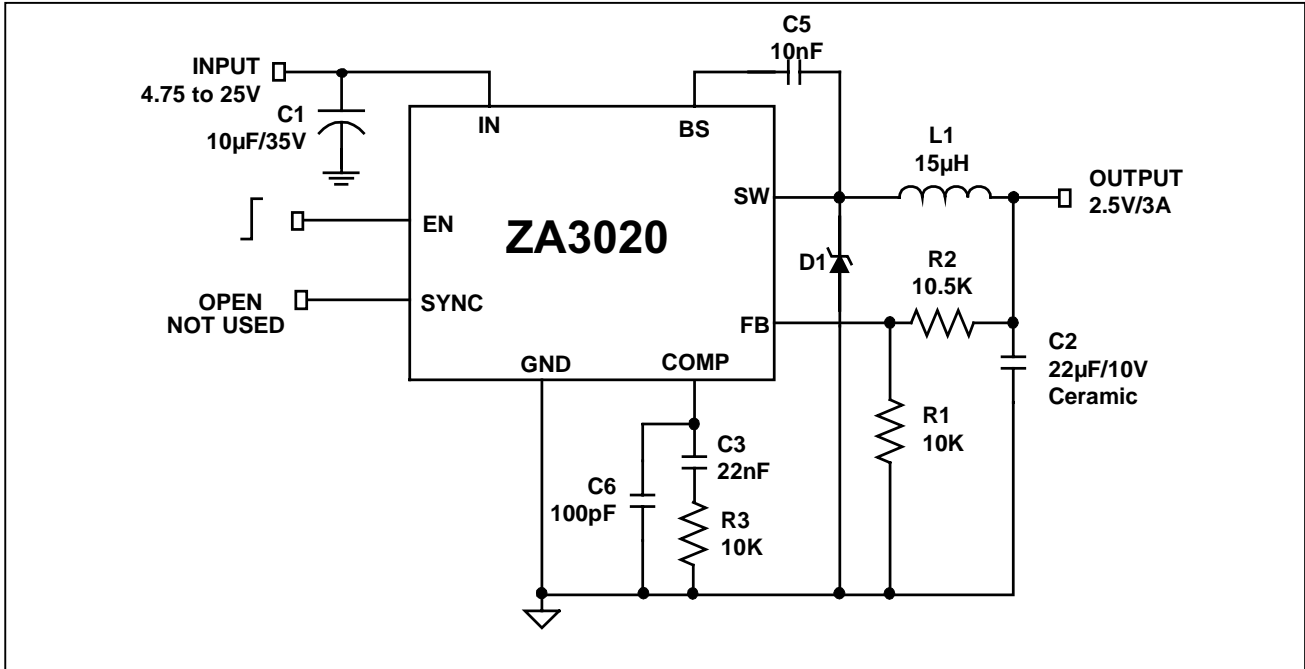

Figure 4: ZA3020 with Panasonic 47 μ F / 6.3V Special Polymer Output Capacitor

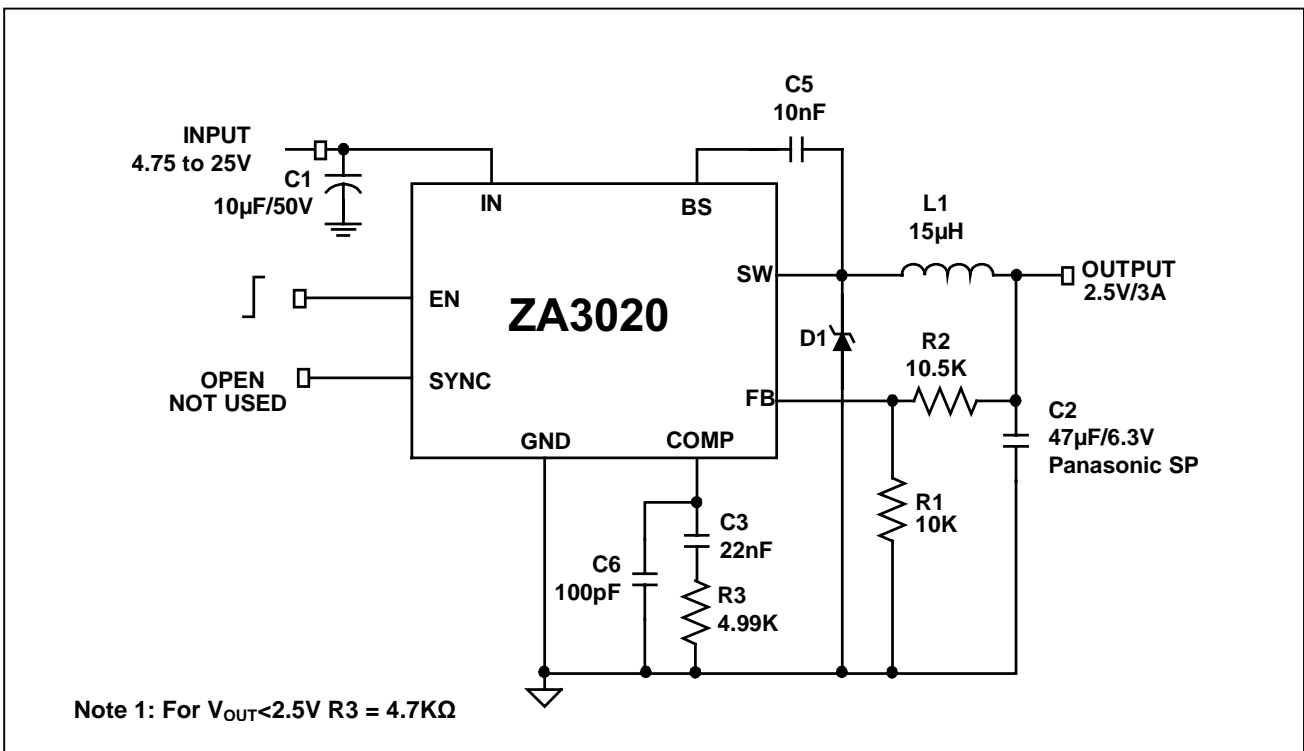
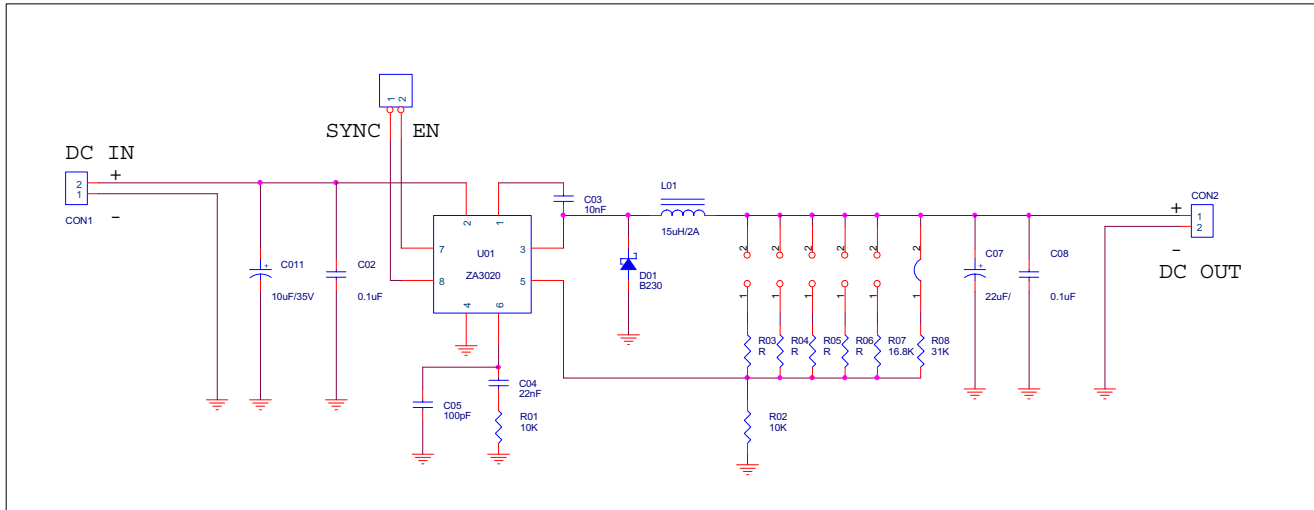

Table 5. Inductor Selection Guide

Vendor/Model	Value (μ H)	Max I_{DC} (A)	Max DCR (Ω)	Core Type	Core Material	Package Dimensions (mm)		
						W	L	H
Sumida								
CR75	10	2.3	0.070	Open	Ferrite	7.0	7.8	5.5
CR75	15	1.8	0.090	Open	Ferrite	7.0	7.8	5.5
CR75	22	1.5	0.110	Open	Ferrite	7.0	7.8	5.5
CDH74	10	2.75	0.056	Open	Ferrite	7.3	8.0	5.2
CDH74	15	2.1	0.083	Open	Ferrite	7.3	8.0	5.2
CDH74	22	1.7	0.130	Open	Ferrite	7.3	8.0	5.2
CDRH5D28	6.8	1.6	0.053	Shielded	Ferrite	5.5	5.7	5.5
CDRH5D28	10	1.3	0.065	Shielded	Ferrite	5.5	5.7	5.5
CDRH5D28	15	1.1	0.103	Shielded	Ferrite	5.5	5.7	5.5
CDRH6D28	6.8	2.3	0.031	Shielded	Ferrite	6.7	6.7	3.0
CDRH6D28	10	1.7	0.065	Shielded	Ferrite	6.7	6.7	3.0
CDRH6D28	15	1.6	0.057	Shielded	Ferrite	6.7	6.7	3.0
CDRH6D28	22	1.3	0.096	Shielded	Ferrite	6.7	6.7	3.0
CDRH6D38	6.8	2.3	0.031	Shielded	Ferrite	6.7	6.7	4.0
CDRH6D38	10	2.0	0.038	Shielded	Ferrite	6.7	6.7	4.0
CDRH6D38	15	1.6	0.057	Shielded	Ferrite	6.7	6.7	4.0
CDRH6D38	22	1.3	0.096	Shielded	Ferrite	6.7	6.7	4.0
CDRH104R	6.8	4.8	0.027	Shielded	Ferrite	10.1	10.0	3.0
CDRH104R	10	4.4	0.035	Shielded	Ferrite	10.1	10.0	3.0
CDRH104R	15	3.6	0.050	Shielded	Ferrite	10.1	10.0	3.0
CDRH104R	22	2.9	0.073	Shielded	Ferrite	10.1	10.0	3.0
Toko								
D53LC Type A	6.8	2.01	0.068	Shielded	Ferrite	5.0	5.0	3.0
D53LC Type A	10	1.77	0.090	Shielded	Ferrite	5.0	5.0	3.0
D53LC Type A	15	1.40	0.142	Shielded	Ferrite	5.0	5.0	3.0
D53LC Type A	22	1.15	0.208	Shielded	Ferrite	5.0	5.0	3.0
D75C	6.8	1.79	0.050	Shielded	Ferrite	7.6	7.6	5.1
D75C	10	1.63	0.055	Shielded	Ferrite	7.6	7.6	5.1
D75C	15	1.33	0.081	Shielded	Ferrite	7.6	7.6	5.1
D75C	22	1.09	0.115	Shielded	Ferrite	7.6	7.6	5.1
D104C	10	4.3	0.0265	Shielded	Ferrite	10.0	10.0	4.3
D104C	16	3.3	0.0492	Shielded	Ferrite	10.0	10.0	4.3
D104C	22	2.5	0.0265	Shielded	Ferrite	10.0	10.0	4.3
D10FL	10	2.26	0.051	Open	Ferrite	9.7	11.5	4.0
D10FL	15	2.00	0.066	Open	Ferrite	9.7	11.5	4.0
D10FL	22	1.83	0.100	Open	Ferrite	9.7	11.5	4.0
Coilcraft								
DO3308	10	2.4	0.030	Open	Ferrite	9.4	13.0	3.0
DO3308	15	2.0	0.040	Open	Ferrite	9.4	13.0	3.0
DO3308	22	1.6	0.050	Open	Ferrite	9.4	13.0	3.0
DO3316	10	3.8	0.030	Open	Ferrite	9.4	13.0	5.1
DO3316	15	3.0	0.040	Open	Ferrite	9.4	13.0	5.1
DO3316	22	2.6	0.050	Open	Ferrite	9.4	13.0	5.1

ZA3020 Demo Board Schematic

This board is laid out to accommodate most commonly used Inductors and Output Capacitors; and to be programmed for most standard Output Voltages. For the required Output voltage solder blob the appropriate J1-6 jumper.



ZA3020 DC-DC

STEP-DOWN CONVERTER

$$V_{out} = 1.222 \frac{R_7 + R_02}{R_02} (V)$$

DEMO BOARD V1.0

4.75 ~ 28V to 1.2 ~ 21V

R?=R03, R04, R05, R06, R07, R08

ZA3020 Demo Board BOM

Item	Quantity	Reference	Part
1	2	C0N1	4 Pin Connector
		C0N2	4 Pin Connector
2	2	C02	0.1uF
		C08	0.1uF
3	1	C03	10nF 0603
4	1	C04	22nF 0603
5	1	C05	100pF 0603
6	1	C011	10uF 35V 1210
7	1	C07	22uF 16V Y5V 1210
8	1	D01	B230/SM 2A 30V Schottky
9	1	L01	15uH
10	2	R01	10K 1%
		R02	10K 1%
11	1	R03	0K 1%
12	1	R04	2.32K 1%
13	1	R05	4.75K 1%
14	1	R06	10.5K 1%
15	1	R07	16.9K 1%
16	1	R08	30.9K 1%
17	1	U01	ZA3020/SO8

Packaging

SOIC8

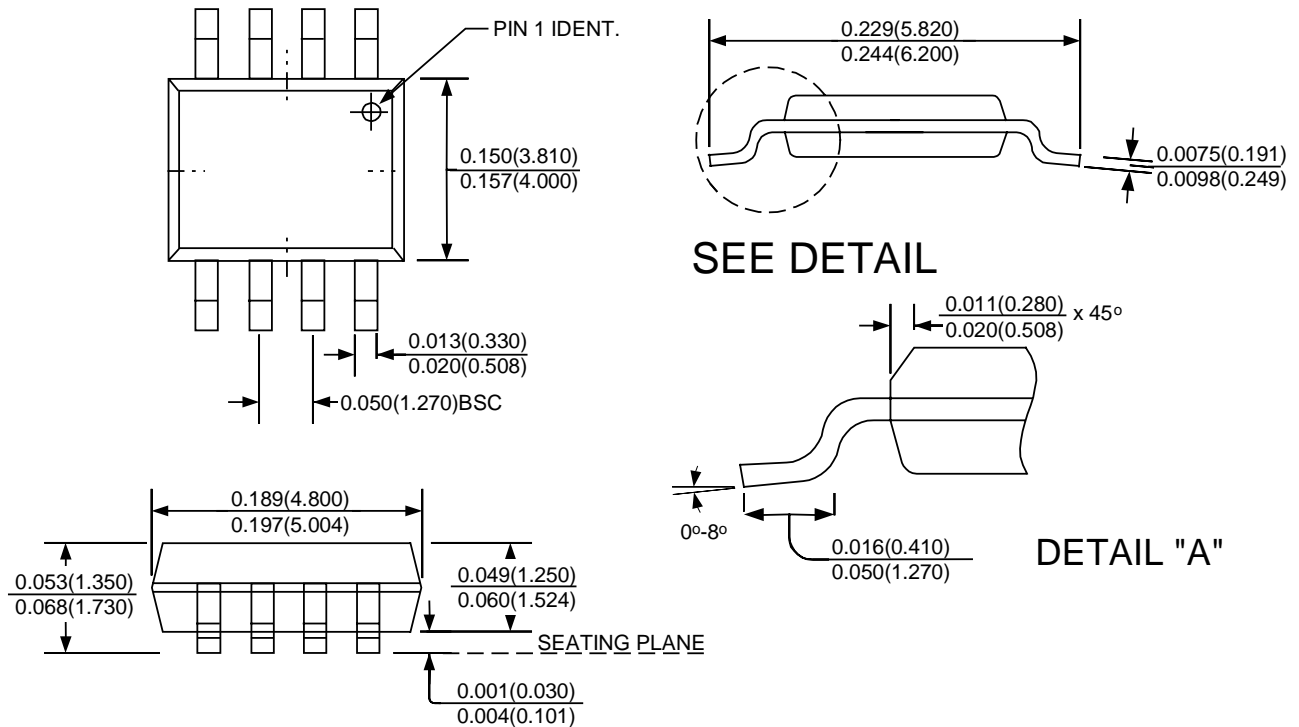

NOTE:

- 1) Control dimension is in inches. Dimension in bracket is millimeters.
- 2) Heat Slug Option Only (N Package)

Notice: Vimicro Corporation believes the information in this document to be accurate and reliable. However, it is subject to change without notice. Please Contact the factory for current specifications No Responsibility is assumed by Vimicro Corporation for its use or fit to any application, nor for infringement of patent or rights of third parties.