

## 2 Megapixel SMIA Camera Module

DATA BRIEF

### Features

- 2 Megapixel resolution sensor (1600 x 1200)
- SMIA 1.0 profile 2 compliant
- Video data interface - CCP 2.0
- Command interface - CCI
- 2.5 V/1.8 V operation
- On-board 10 bit ADC
- Small physical size
- Integral EMC shielding
- Ultra low power standby mode
- On-chip PLL
- On-chip POR
- Smooth frame rate control
- Automatic dark level calibration

### Description

The VS6750 is a 2 Megapixel camera module targeted at mobile applications.

The camera module is SMIA 1.0 profile 2 compliant and is capable of generating raw bayer UXGA images up to a maximum of 30 fps. The VS6750 supports the CCI control and CCP 2.0 data interfaces.

As different phone platforms have varying image processing capabilities and interfaces, it is possible that the system host may not handle the processing tasks required if connecting the VS6750 directly, or that the resulting frame rate performance may be too low. In such cases, a separate hardware accelerator (STV0984) device can be incorporated in the system to provide higher performances and/or a wider choice of interfaces.

VS6750 offers an ultra low power consumption standby mode consuming less than 30  $\mu$ W.

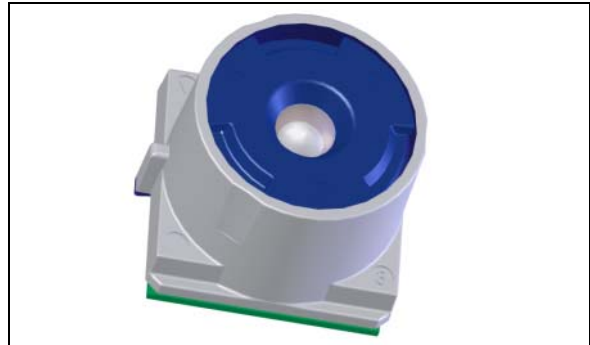

The VS6750 features allow straightforward integration into mobile phone designs: low EMI video interface and package/socket shielding, low wire count (8 total), embedded power management (30  $\mu$ W power-down) and embedded PLL.

A minimal list of external components is required: supply decoupling capacitors, CCI pull-ups and a charge-pump capacitor.

The VS6750 3-element lens design ensures high quality image capture while maintaining low module height. The overall optical stack, including lens system, IR filter and sensor optical structures is developed within ST.

The VS6750 package uses the second generation of SmOP packaging technology. Sensor and lens are assembled in a fully automated test and focus process for high volume and low cost production. This 2 Megapixel sensor fits within the SMIA95 form factor (9.5 x 9.5 x 7.6 mm<sup>3</sup>).

### Applications

- Mobile phone
- PDA
- Wireless security camera

**Figure 1. Application diagram**

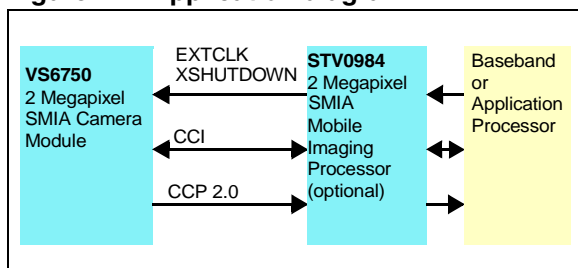

**Figure 2. Block diagram**

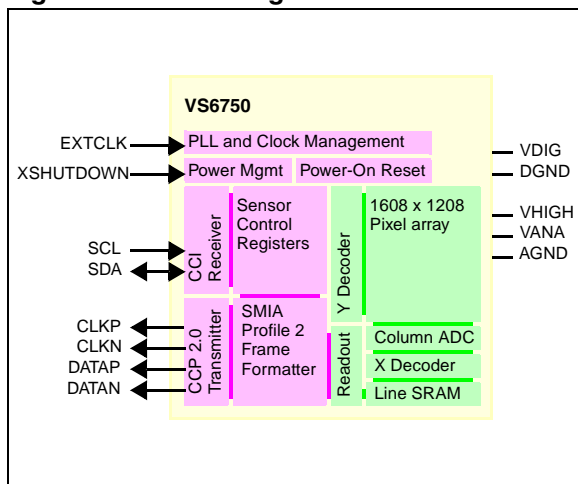

**Figure 3. Outline Drawing**

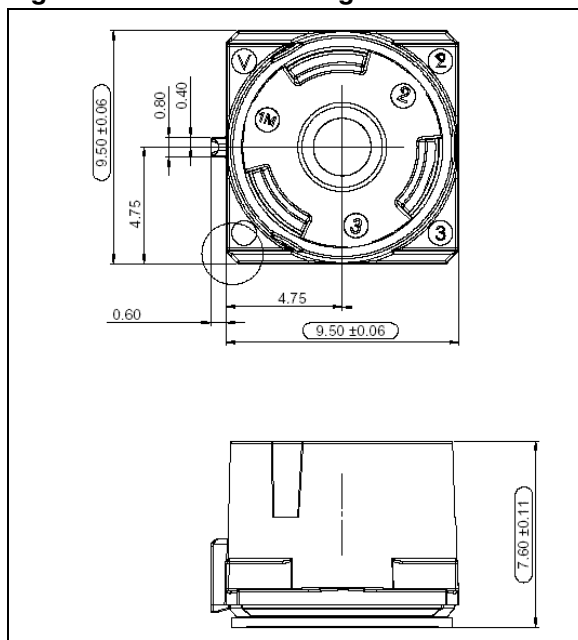

**Table 1. Technical specifications**

Module resolution	1600 x 1200 (UXGA)
Physical pixel array	1608 x 1208
Pixel size	3.0 μm x 3.0 μm
Sensor technology	0.18um HCMOS8is
Exposure control	+120 dB
Analog gain	+24 dB (max.)
Dynamic range	60 dB (typical)
SNR at 50 cd.m <sup>2</sup>	33 dB (typical)
Supply voltage	2V4 - 2V9 (analog supply) 1V7 - 1V9 (digital supply)
Power consumption	<235 mW (@30 frame/s) <30 μW (standby mode)
Lens	50° HFOV, f# 3.2
Depth of Field	70 cm -> infinity
Package type	16 pad SMIA95
TV Distortion	< 2%
Relative illumination	50%
System attach	Socket or Flex

**Table 2. Temperature range**

Storage	-40 to +85°C
Functional	-30 to +70°C
Normal operating	-25 to +55 °C
Optimal operating	+5 to +30°C
Test	23 ± 2°C

**Table 3. Order codes**

Part Number	Description
VS6750S02F/T2	SmOP2 SMIA95 tape and reel

## Revision history

Date	Revision	Changes
21-Sept-2005	1	Initial release.

---

Information furnished is believed to be accurate and reliable. However, STMicroelectronics assumes no responsibility for the consequences of use of such information nor for any infringement of patents or other rights of third parties which may result from its use. No license is granted by implication or otherwise under any patent or patent rights of STMicroelectronics. Specifications mentioned in this publication are subject to change without notice. This publication supersedes and replaces all information previously supplied. STMicroelectronics products are not authorized for use as critical components in life support devices or systems without express written approval of STMicroelectronics.

The ST logo is a registered trademark of STMicroelectronics.  
All other names are the property of their respective owners

© 2005 STMicroelectronics - All rights reserved

STMicroelectronics group of companies

Australia - Belgium - Brazil - Canada - China - Czech Republic - Finland - France - Germany - Hong Kong - India - Israel - Italy - Japan -  
Malaysia - Malta - Morocco - Singapore - Spain - Sweden - Switzerland - United Kingdom - United States of America

[www.st.com](http://www.st.com)

