

DESCRIPTION

This surface mount series of industry recognized voidless-hermetically-sealed Unidirectional Transient Voltage Suppressor (TVS) designs is military qualified to MIL-PRF-19500/552 and are ideal for high-reliability applications where a failure cannot be tolerated. They provide a Working Peak "Standoff" Voltage selection from 5.0 to 51.6 Volts with 1500 W ratings. They are very robust in hard-glass construction and also use an internal metallurgical bond identified as Category I for high reliability applications. The 1500 W series is military qualified to MIL-PRF-19500/552. These devices are also available in axial-leaded packages for thru-hole mounting by deleting the "US" suffix (see separate data sheet for 1N6469 thru 1N6476A). Microsemi also offers numerous other TVS products to meet higher and lower peak pulse power and voltage ratings in both through-hole and surface-mount packages.

APPEARANCE

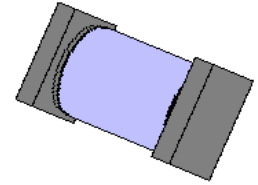

Package "G"
(or "D-5C")

IMPORTANT: For the most current data, consult MICROSEMI's website: <http://www.microsemi.com>

FEATURES

- High surge current and peak pulse power provides transient voltage protection for sensitive circuits
- Triple-layer passivation
- Internal "Category I" metallurgical bonds
- Voidless hermetically sealed glass package
- JAN/TX/TXV military qualifications available per MIL-PRF-19500/552 by adding JAN, JANTX, or JANTXV prefix
- Further options for screening in accordance with MIL-PRF-19500 for JANS by using a "MSP" prefix, e.g. MSP6469, MSP6476, etc.
- Axial-leaded equivalents are also available (see separate data sheet for 1N6469 thru 1N6476)

APPLICATIONS / BENEFITS

- Military and other high reliability transient protection
- Extremely robust construction
- Working Peak "Standoff" Voltage (V_{WM}) from 5.0 to 51.6 V
- Available as 1500 W Peak Pulse Power (P_{PP})
- ESD and EFT protection per IEC61000-4-2 and IEC61000-4-4 respectively
- Secondary lightning protection per select levels in IEC61000-4-5
- Square-end-cap terminals for easy mounting
- Nonsensitive to ESD per MIL-STD-750 Method 1020
- Inherently radiation hard as described in Microsemi MicroNote 050

MAXIMUM RATINGS

- Operating & Storage Temperature: -55°C to $+175^{\circ}\text{C}$
- Peak Pulse Power at 25°C : 1500 Watts @ 10/1000 μs (also see Figures 1,2 and 4)
- Impulse repetition rate (duty factor): 0.01%
- Forward Surge Current: 130 Amps @ 8.33 ms one-half sine wave
- Forward Voltage: 1.5 V @ 4 Amps dc and 4.8 V at 100 Amps (pulsed)
- Steady-State Power: 3.0 W @ $T_A = 25^{\circ}\text{C}$ (see note below and Figure 4)
- Thermal Resistance Junction to End Cap: 20.0°C/W
- Solder Temperatures: 260°C for 10 s (maximum)

MECHANICAL AND PACKAGING

- CASE: Hermetically sealed voidless hard glass with Tungsten slugs
- TERMINATIONS: Axial-leads are Tin/Lead (Sn/Pb) over copper
- MARKING: Body painted and part number, etc.
- POLARITY: Cathode band
- Tape & Reel option: Standard per EIA-481-B
- Weight: 1100 mg
- See package dimensions on last page

NOTE: Steady-state power ratings with reference to ambient are for PC boards where thermal resistance from mounting point to ambient is sufficiently controlled where $T_{J(\text{MAX})}$ is not exceeded.

ELECTRICAL CHARACTERISTICS

TYPE	BREAK DOWN VOLTAGE V(BR) MIN.	BREAKDOWN CURRENT I(BR)	WORKING PEAK VOLTAGE V _{WM}	MAX LEAKAGE CURRENT I _D	MAXIMUM CLAMPING VOLTAGE V _C @ 10/1000 μs	MAXIMUM PEAK PULSE CURRENT I _{PP}		MAXIMUM TEMP. COEF. OF V(BR)
						@8/20 μs	@10/1000 μs	
	Volts	mAdc	Vdc	μAdc	V(pk)	A(pk)	A(pk)	%/°C
1N6469US	5.6	50	5	500	9.0	945	167	-.03, +0.04
1N6470US	6.5	50	6	100	11.0	775	137	0.06
1N6471US	13.6	10	12	20	22.6	374	66	0.085
1N6472US	16.4	10	15	10	26.5	322	57	0.085
1N6473US	27.0	5	24	5	41.4	207	36.5	.096
1N6474US	33.0	1	30.5	5	47.5	181	32	.098
1N6475US	43.7	1	40.3	5	63.5	135	24	.101
1N6476US	54.0	1	51.6	5	78.5	107	19	.103

SYMBOLS & DEFINITIONS

Symbol	Definition
V _{BR}	Minimum Breakdown Voltage: The minimum voltage the device will exhibit at a specified current.
V _{WM}	Working Peak Voltage: The maximum peak voltage that can be applied over the operating temperature range. This is also referred to as Standoff Voltage.
I _D	Maximum Standoff Current: The maximum current that will flow at the specified voltage and temperature.
V _C	Maximum clamping voltage at specified I _{PP} (Peak Pulse Current) at the specified pulse conditions.
P _{PP}	Peak Pulse Power: The peak power dissipation resulting from the peak impulse current I _{PP} .

GRAPHS

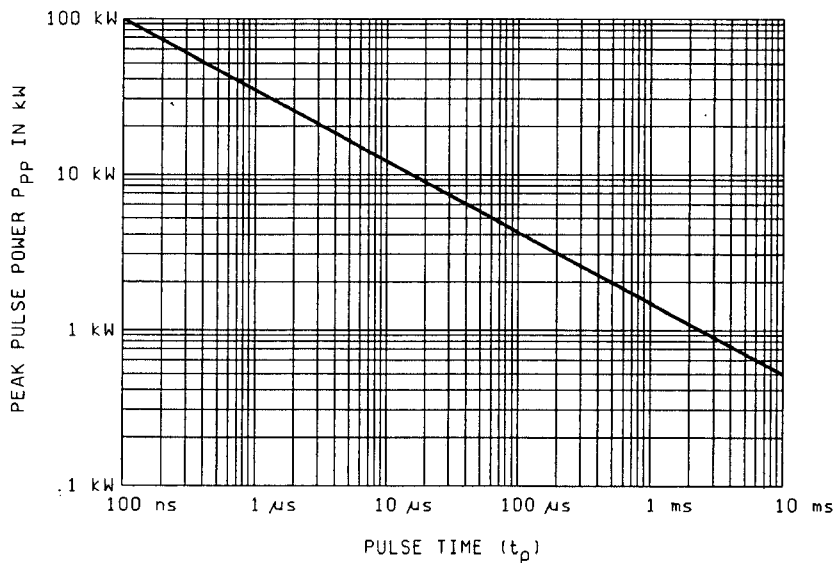

FIG. 1 – Non-repetitive peak pulse power rating curve
NOTE: Peak power defined as peak voltage times peak current

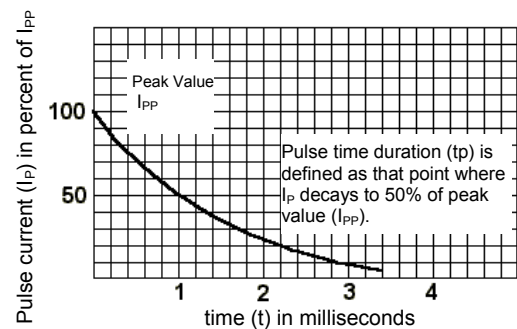

FIG. 2 Pulse wave form for exponential surge for 10/1000 μs

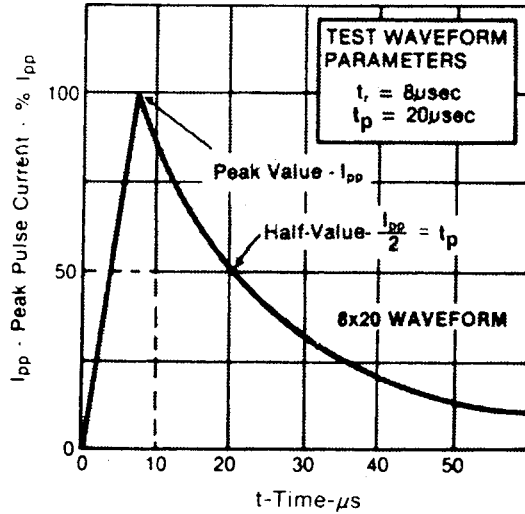

FIGURE 3
8/20 μ s CURRENT IMPULSE WAVEFORM

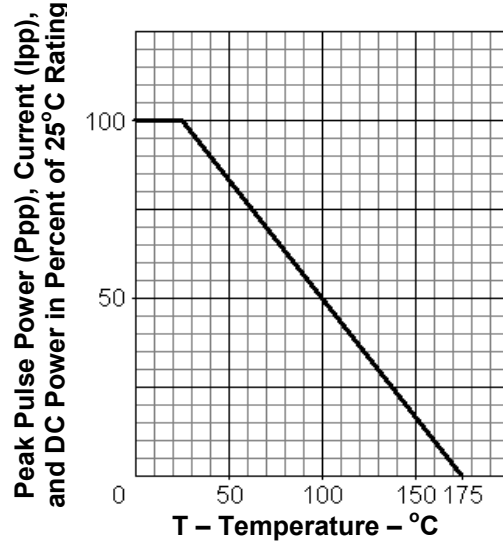
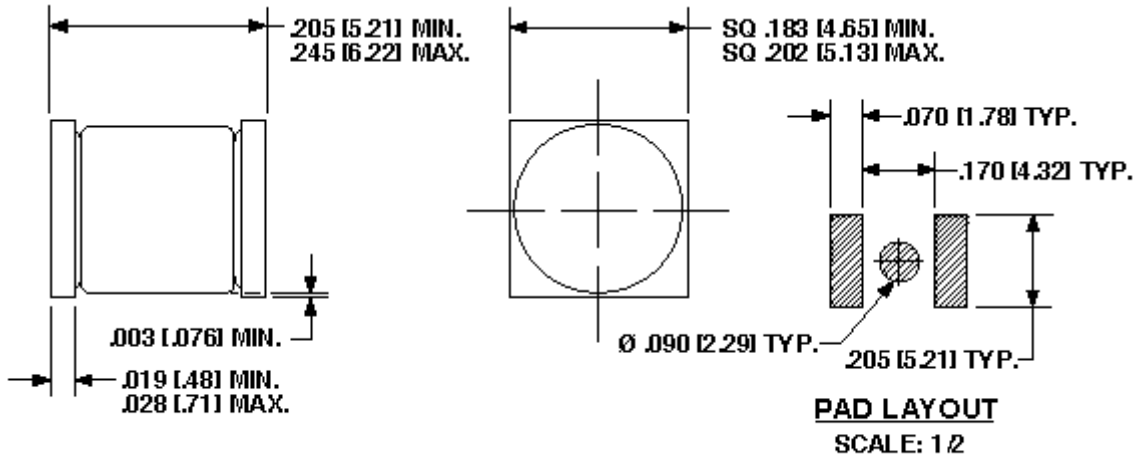

FIGURE 4
DERATING CURVE

PACKAGE DIMENSIONS Inches [mm]



NOTE: DIMENSIONS IN INCHES [MM]
G-MELF-PKG (D-5C)

Note: If mounting requires adhesive separate from the solder, an additional 0.090 inch diameter contact may be placed in the center between the pads as an optional spot for cement as shown in the pad layout.