

1997-4/1  
MITSUBISHI LSIs

# M5M51008BP,FP,VP,RV,KV,KR -55L,-70L,-10L, -55LL,-70LL,-10LL-I

1048576-BIT(131072-WORD BY 8-BIT)CMOS STATIC RAM

## DESCRIPTION

The M5M51008BP,FP,VP,RV,KV,KR are a 1048576-bit CMOS static RAM organized as 131072 word by 8-bit which are fabricated using high-performance triple polysilicon CMOS technology. The use of resistive load NMOS cells and CMOS periphery result in a high density and low power static RAM.

They are low standby current and low operation current and ideal for the battery back-up application.

The M5M51008BVP,RV,KV,KR are packaged in a 32-pin thin small outline package which is a high reliability and high density surface mount device(SMD).Two types of devices are available.

VP,KV(normal lead bend type package),RV,KR(reverse lead bend type package). Using both types of devices, it becomes very easy to design a printed circuit board.

## FEATURES

Type name	Access time (max)	Power supply current	
		Active (1MHz) (max)	stand-by (max)
M5M51008BP,FP,VP,RV,KV,KR-55L	55ns	15mA	200µA (V <sub>CC</sub> =5.5V)
M5M51008BP,FP,VP,RV,KV,KR-70L	70ns		
M5M51008BP,FP,VP,RV,KV,KR-10L	100ns		
M5M51008BP,FP,VP,RV,KV,KR-55LL	55ns	15mA	40µA (V <sub>CC</sub> =5.5V) 0.3µA (V <sub>CC</sub> =3.0V,typ)
M5M51008BP,FP,VP,RV,KV,KR-70LL	70ns		
M5M51008BP,FP,VP,RV,KV,KR-10LL	100ns		

- Single +5V power supply
- Low stand-by current 0.3µA (typ.)
- Directly TTL compatible : All inputs and outputs
- Easy memory expansion and power down by  $\overline{S}_1, S_2$
- Data hold on +2V power supply
- Three-state outputs : OR - tie capability
- $\overline{OE}$  prevents data contention in the I/O bus
- Common data I/O
- Package
  - M5M51008BP ..... 32pin 600mil DIP
  - M5M51008BFP ..... 32pin 525mil SOP
  - M5M51008BVP,RV ..... 32pin 8 X 20 mm<sup>2</sup> TSOP
  - M5M51008BKV,KR ..... 32pin 8 X 13.4 mm<sup>2</sup> TSOP

## APPLICATION

Small capacity memory units

## PIN CONFIGURATION (TOP VIEW)

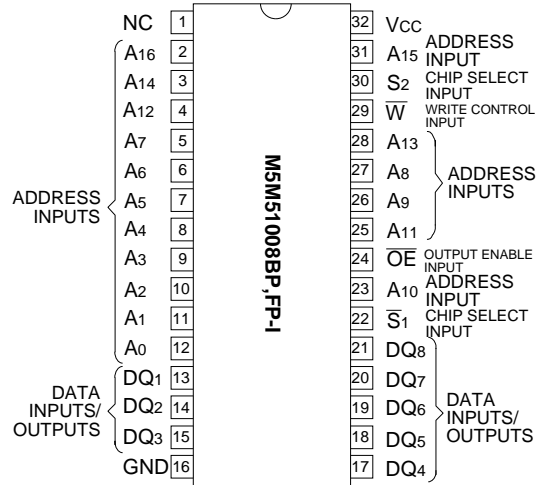

Outline 32P4(P), 32P2M-A(FP)

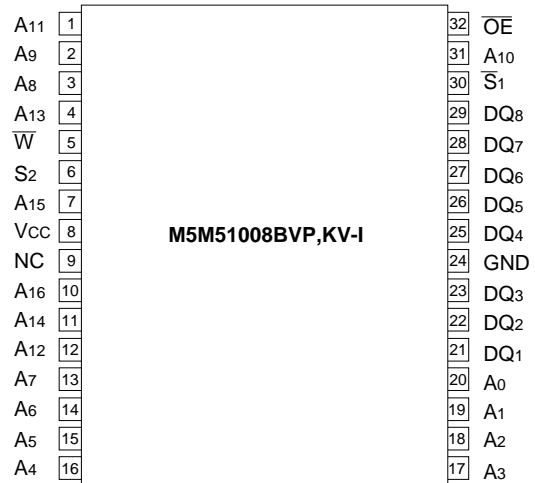

Outline 32P3H-E(VP), 32P3K-B(KV)

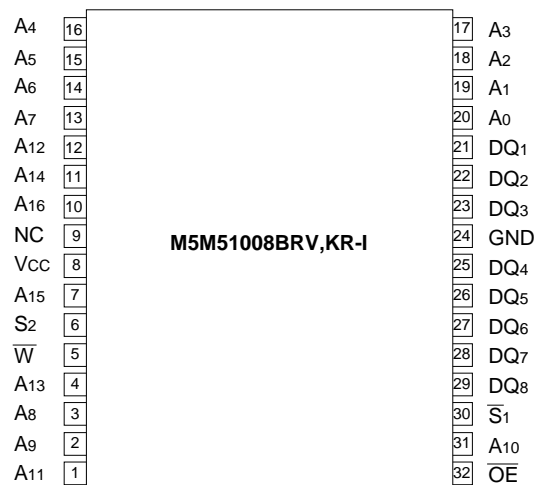

Outline 32P3H-F(RV), 32P3K-C(KR)

NC : NO CONNECTION

1997-4/1  
MITSUBISHI LSIs

# M5M51008BP,FP,VP,RV,KV,KR -55L,-70L,-10L, -55LL,-70LL,-10LL-I

1048576-BIT(131072-WORD BY 8-BIT)CMOS STATIC RAM

## FUNCTION

The operation mode of the M5M51008B series are determined by a combination of the device control inputs  $\bar{S}_1, S_2, \bar{W}$  and  $\bar{OE}$ .

Each mode is summarized in the function table.

A write cycle is executed whenever the low level  $\bar{W}$  overlaps with the low level  $\bar{S}_1$  and the high level  $S_2$ . The address must be set up before the write cycle and must be stable during the entire cycle. The data is latched into a cell on the trailing edge of  $\bar{W}, \bar{S}_1$  or  $S_2$ , whichever occurs first, requiring the set-up and hold time relative to these edge to be maintained. The output enable input  $\bar{OE}$  directly controls the output stage. Setting the  $\bar{OE}$  at a high level, the output stage is in a high-impedance state, and the data bus contention problem in the write cycle is eliminated.

A read cycle is executed by setting  $\bar{W}$  at a high level and  $\bar{OE}$  at a low level while  $\bar{S}_1$  and  $S_2$  are in an active state ( $\bar{S}_1=L, S_2=H$ ).

When setting  $\bar{S}_1$  at a high level or  $S_2$  at a low level, the chip are in a non-selectable mode in which both reading and writing are disabled. In this mode, the output stage is in a high-impedance state, allowing OR-tie with other chips and memory expansion by  $\bar{S}_1$  and  $S_2$ . The power supply current is reduced as low as the stand-by current which is specified as  $I_{CC3}$  or  $I_{CC4}$ , and the memory data can be held at +2V power supply, enabling battery back-up operation during power failure or power-down operation in the non-selected mode.

## FUNCTION TABLE

$\bar{S}_1$	$S_2$	$\bar{W}$	$\bar{OE}$	Mode	DQ	$I_{CC}$
X	L	X	X	Non selection	High-impedance	Stand-by
H	X	X	X	Non selection	High-impedance	Stand-by
L	H	L	X	Write	Din	Active
L	H	H	L	Read	Dout	Active
L	H	H	H		High-impedance	Active

## BLOCK DIAGRAM

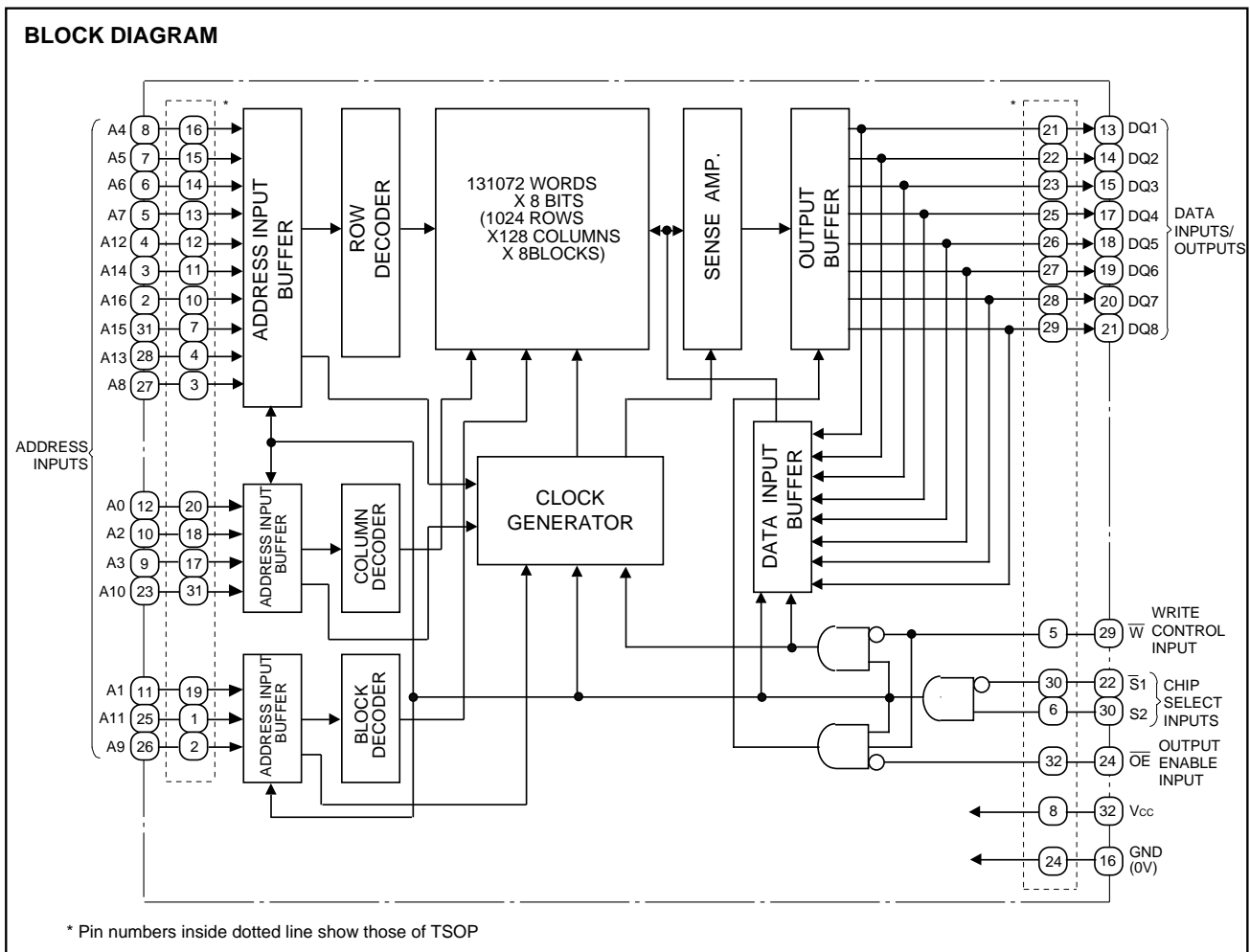

1997-4/1  
MITSUBISHI LSIs

# M5M51008BP,FP,VP,RV,KV,KR -55L,-70L,-10L, -55LL,-70LL,-10LL-I

1048576-BIT(131072-WORD BY 8-BIT)CMOS STATIC RAM

## ABSOLUTE MAXIMUM RATINGS

Symbol	Parameter	Conditions	Ratings	Unit
V <sub>CC</sub>	Supply voltage	With respect to GND	- 0.3*~7	V
V <sub>I</sub>	Input voltage		- 0.3*~V <sub>CC</sub> + 0.3	V
V <sub>O</sub>	Output voltage		0~V <sub>CC</sub>	V
P <sub>d</sub>	Power dissipation	T <sub>a</sub> =25°C	700	mW
T <sub>opr</sub>	Operating temperature		- 40~85	°C
T <sub>stg</sub>	Storage temperature		- 65~150	°C

\* -3.0V in case of AC ( Pulse width 30ns )

## DC ELECTRICAL CHARACTERISTICS (T<sub>a</sub> = -40~85°C, V<sub>CC</sub>=5V±10%, unless otherwise noted)

Symbol	Parameter	Test conditions	Limits			Unit
			Min	Typ	Max	
V <sub>IH</sub>	High-level input voltage		2.2		V <sub>CC</sub> +0.3V	V
V <sub>IL</sub>	Low-level input voltage		-0.3*		0.8	V
V <sub>OH1</sub>	High-level output voltage 1	I <sub>OH</sub> = -0.5mA	2.4			V
V <sub>OH2</sub>	High-level output voltage 2	I <sub>OH</sub> = -0.05mA	V <sub>CC</sub> -0.5V			V
V <sub>OL</sub>	Low-level output voltage	I <sub>OL</sub> =2mA			0.4	V
I <sub>I</sub>	Input current	V <sub>I</sub> =0~V <sub>CC</sub>			±1	μA
I <sub>O</sub>	Output current in off-state	$\bar{S}_1=V_{IH}$ or $S_2=V_{IL}$ or $OE=V_{IH}$ V <sub>I/O</sub> =0~V <sub>CC</sub>			±1	μA
I <sub>CC1</sub>	Active supply current (AC, MOS level)	$\bar{S}_1$ 0.2V, S <sub>2</sub> V <sub>CC</sub> -0.2V, other inputs 0.2V or V <sub>CC</sub> -0.2V Output-open(duty 100%)	Min cycle	35 (40)**	70 (80)**	mA
			1MHz	4	15	
I <sub>CC2</sub>	Active supply current (AC, TTL level)	$\bar{S}_1=V_{IL}$ , S <sub>2</sub> =V <sub>IH</sub> , other inputs=V <sub>IH</sub> or V <sub>IL</sub> Output-open(duty 100%)	Min cycle	38 (43)**	70 (85)**	mA
			1MHz	5	15	
I <sub>CC3</sub>	Stand-by current	1) S <sub>2</sub> 0.2V 2) $\bar{S}_1$ V <sub>CC</sub> -0.2V, S <sub>2</sub> V <sub>CC</sub> -0.2V other inputs=0~V <sub>CC</sub>	-L		100	μA
			-LL		20	
I <sub>CC4</sub>	Stand-by current	$\bar{S}_1=V_{IH}$ or $S_2=V_{IL}$ , other inputs=0~V <sub>CC</sub>			3	mA

\* -3.0V in case of AC ( Pulse width 30ns )

\*\* inside ( ) is a value of -55L,-55LL

## CAPACITANCE (T<sub>a</sub> = -40~85°C, V<sub>CC</sub>=5V±10%, unless otherwise noted)

Symbol	Parameter	Test conditions	Limits			Unit
			Min	Typ	Max	
C <sub>I</sub>	Input capacitance	V <sub>I</sub> =GND, V <sub>I</sub> =25mVrms, f=1MHz			6	pF
C <sub>O</sub>	Output capacitance	V <sub>O</sub> =GND, V <sub>O</sub> =25mVrms, f=1MHz			8	pF

Note 1: Direction for current flowing into an IC is positive (no mark).

2: Typical value is V<sub>CC</sub> = 5V, T<sub>a</sub> = 25°C

1997-4/1  
MITSUBISHI LSIs

# M5M51008BP,FP,VP,RV,KV,KR -55L,-70L,-10L, -55LL,-70LL,-10LL-I

1048576-BIT(131072-WORD BY 8-BIT)CMOS STATIC RAM

**AC ELECTRICAL CHARACTERISTICS** (Ta = -40~85°C, Vcc=5V±10%, unless otherwise noted)

**(1) MEASUREMENT CONDITIONS**

Input pulse level ..... VIH=2.4V, VIL=0.6V (-70L,-10L,-70LL,-10LL)  
 VIH=3.0V, VIL=0.0V (-55L,-55LL)  
 Input rise and fall time ..... 5ns  
 Reference level ..... VOH=VOL=1.5V  
 Output loads ..... Fig.1, CL=100pF (-10L,-10LL,) CL=30pF (-55L,-70L,-55LL,-70LL) CL=5pF (for ten, tdis)  
 Transition is measured ± 500mV from steady state voltage. (for ten, tdis)

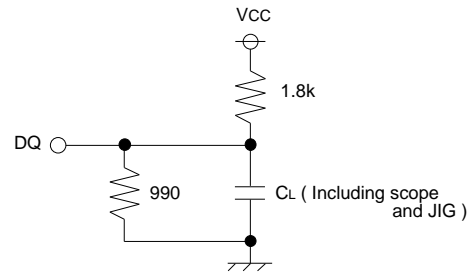

Fig.1 Output load

**(2) READ CYCLE**

Symbol	Parameter	Limits						Unit
		-55L,LL		-70L,LL		-10L,LL		
		Min	Max	Min	Max	Min	Max	
tCR	Read cycle time	55		70		100		ns
ta(A)	Address access time		55		70		100	ns
ta(S1)	Chip select 1 access time		55		70		100	ns
ta(S2)	Chip select 2 access time		55		70		100	ns
ta(OE)	Output enable access time		30		35		50	ns
tdis(S1)	Output disable time after $\overline{S1}$ high		20		25		35	ns
tdis(S2)	Output disable time after $\overline{S2}$ low		20		25		35	ns
tdis(OE)	Output disable time after $\overline{OE}$ high		20		25		35	ns
ten(S1)	Output enable time after $\overline{S1}$ low	5		10		10		ns
ten(S2)	Output enable time after $\overline{S2}$ high	5		10		10		ns
ten(OE)	Output enable time after $\overline{OE}$ low	5		5		5		ns
tV(A)	Data valid time after address	5		10		10		ns

**(3) WRITE CYCLE**

Symbol	Parameter	Limits						Unit
		-55L,LL		-70L,LL		-10L,LL		
		Min	Max	Min	Max	Min	Max	
tcw	Write cycle time	55		70		100		ns
tw(W)	Write pulse width	45		55		75		ns
tsu(A)	Address setup time	0		0		0		ns
tsu(A-WH)	Address setup time with respect to $\overline{W}$	50		65		85		ns
tsu(S1)	Chip select 1 setup time	50		65		85		ns
tsu(S2)	Chip select 2 setup time	50		65		85		ns
tsu(D)	Data setup time	25		30		40		ns
th(D)	Data hold time	0		0		0		ns
trec(W)	Write recovery time	0		0		0		ns
tdis(W)	Output disable time from $\overline{W}$ low		20		25		35	ns
tdis(OE)	Output disable time from $\overline{OE}$ high		20		25		35	ns
ten(W)	Output enable time from $\overline{W}$ high	5		5		5		ns
ten(OE)	Output enable time from $\overline{OE}$ low	5		5		5		ns

1997-4/1  
**MITSUBISHI LSIs**  
**M5M51008BP,FP,VP,RV,KV,KR -55L,-70L,-10L,**  
**-55LL,-70LL,-10LL-I**  
**1048576-BIT(131072-WORD BY 8-BIT)CMOS STATIC RAM**

**(4) TIMING DIAGRAMS**

**Read cycle**

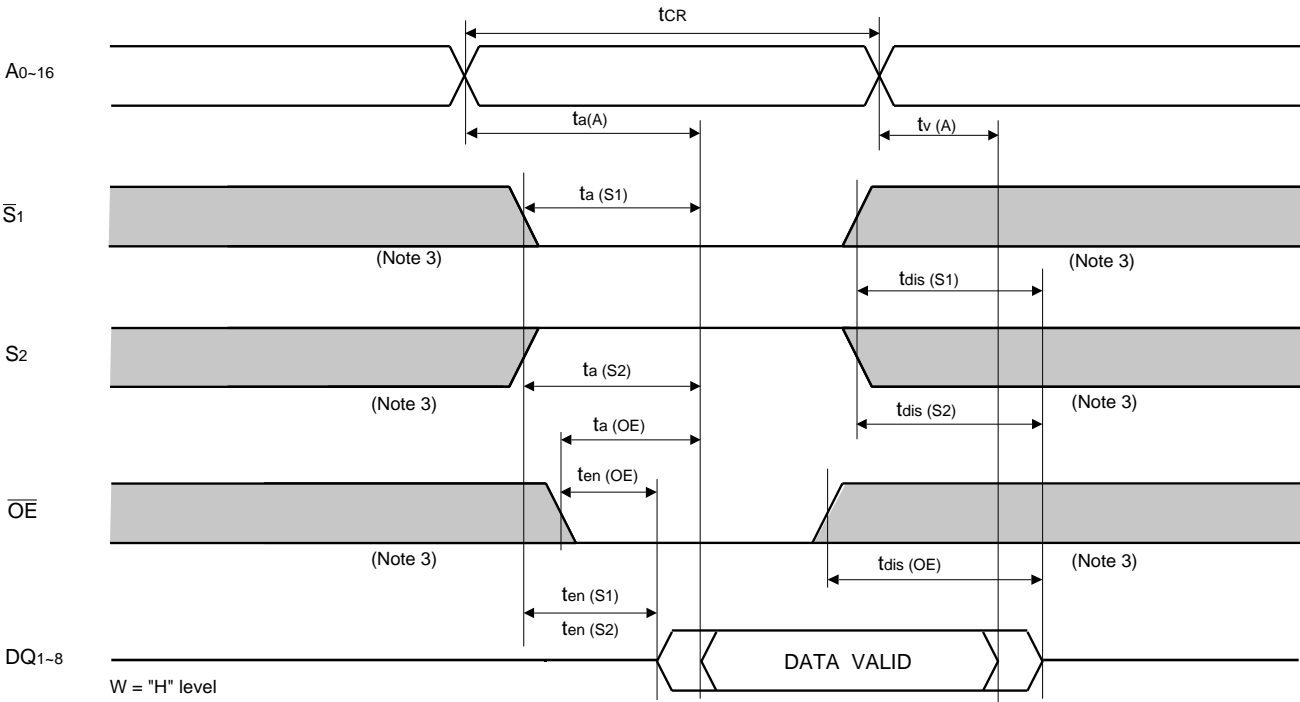

**Write cycle ( $\overline{W}$  control mode)**

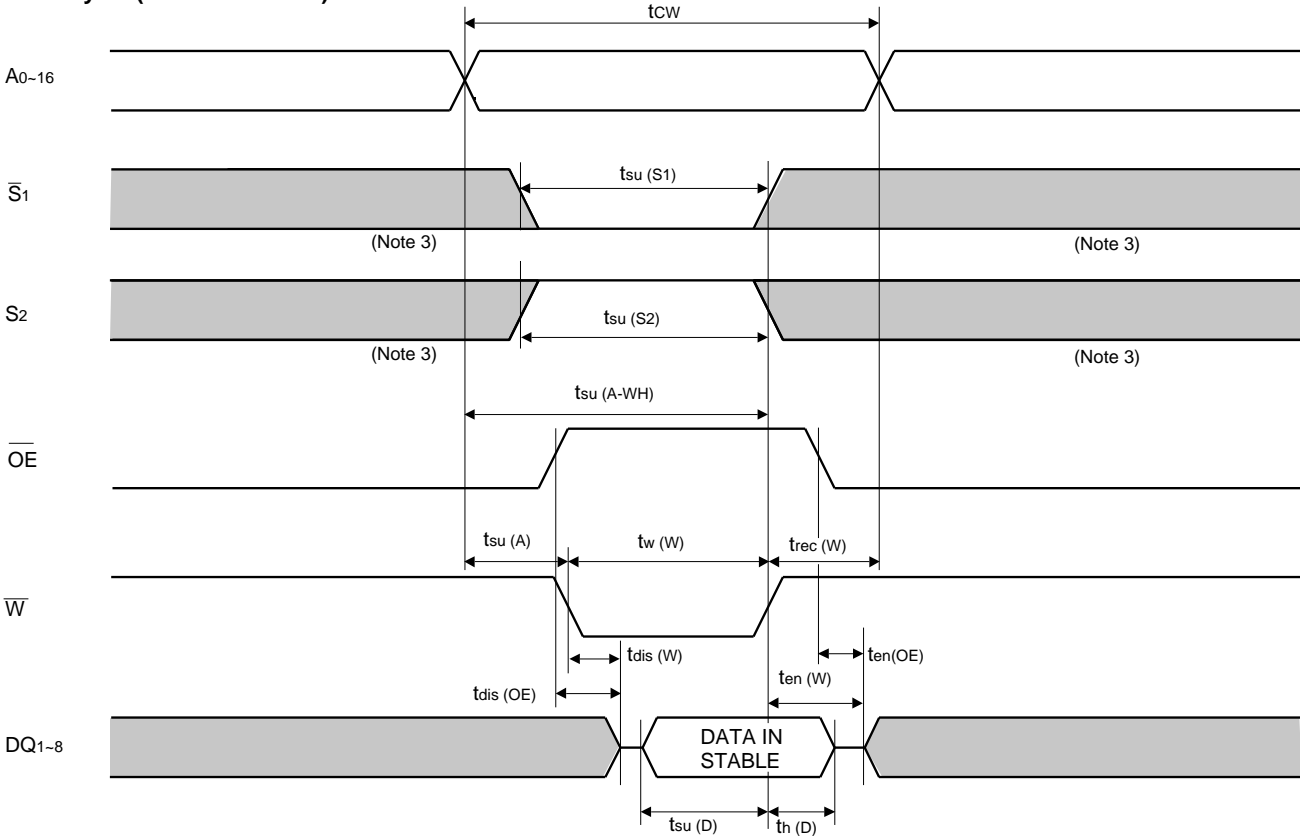

1997-4/1  
MITSUBISHI LSIs

# M5M51008BP,FP,VP,RV,KV,KR -55L,-70L,-10L, -55LL,-70LL,-10LL-I

1048576-BIT(131072-WORD BY 8-BIT)CMOS STATIC RAM

**Write cycle ( $\overline{S1}$  control mode)**

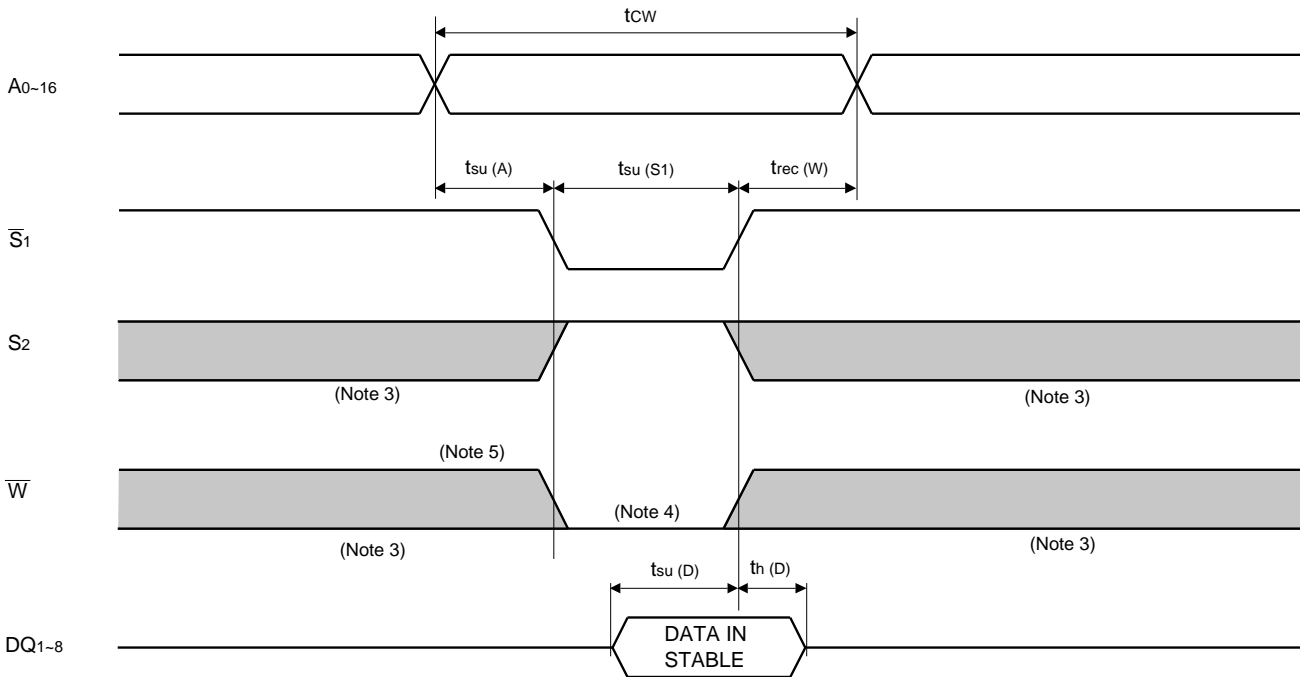

**Write cycle (S2 control mode)**

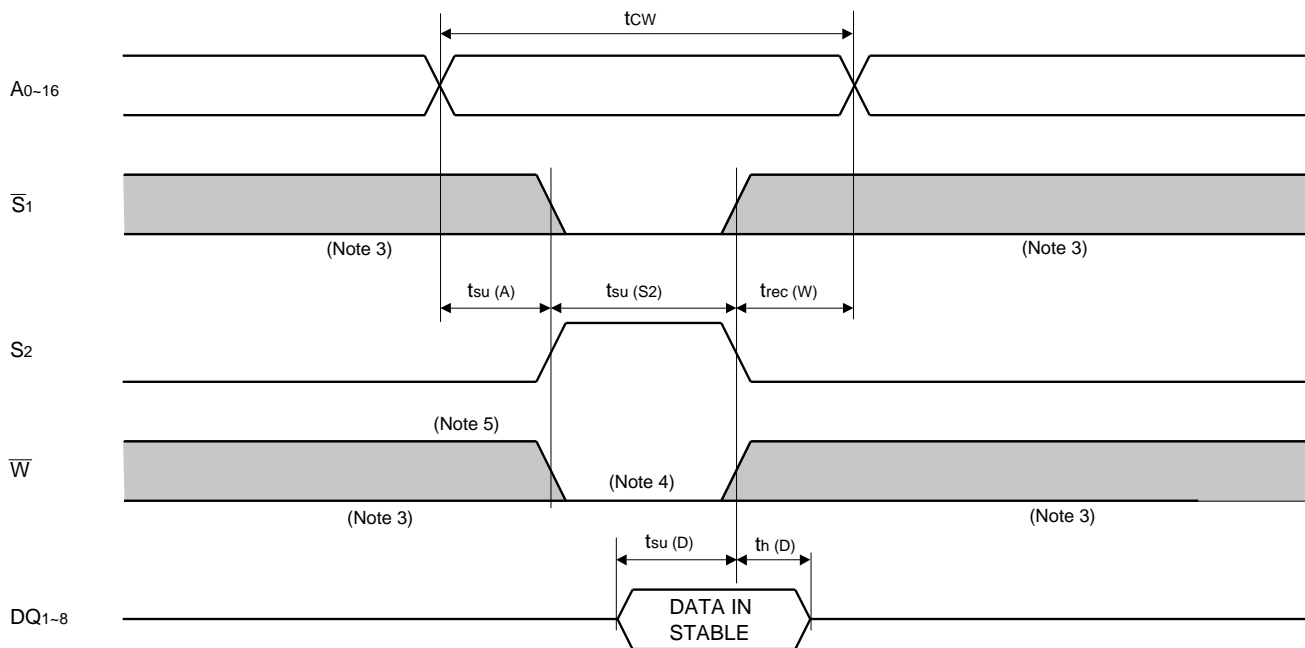

- Note 3: Hatching indicates the state is "don't care".  
 4: Writing is executed while S2 high overlaps  $\overline{S1}$  and  $\overline{W}$  low.  
 5: When the falling edge of  $\overline{W}$  is simultaneously or prior to the falling edge of  $\overline{S1}$  or rising edge of S2, the outputs are maintained in the high impedance state.  
 6: Don't apply inverted phase signal externally when DQ pin is output mode.

1997-4/1  
**MITSUBISHI LSIs**  
**M5M51008BP,FP,VP,RV,KV,KR -55L,-70L,-10L,**  
**-55LL,-70LL,-10LL-I**  
**1048576-BIT(131072-WORD BY 8-BIT)CMOS STATIC RAM**

**POWER DOWN CHARACTERISTICS**

**(1) ELECTRICAL CHARACTERISTICS** (Ta = -40~85°C, unless otherwise noted)

Symbol	Parameter	Test conditions	Limits			Unit
			Min	Typ	Max	
V <sub>CC (PD)</sub>	Power down supply voltage		2			V
V <sub>I (S1)</sub>	Chip select input $\bar{S}_1$	2.2V V <sub>CC(PD)</sub>	2.2			V
		2V V <sub>CC(PD)</sub> 2.2V		V <sub>CC(PD)</sub>		
V <sub>I (S2)</sub>	Chip select input S <sub>2</sub>	4.5V V <sub>CC(PD)</sub>			0.8	V
		V <sub>CC(PD)</sub> < 4.5V			0.2	
I <sub>CC (PD)</sub>	Power down supply current	V <sub>CC</sub> = 3V 1) S <sub>2</sub> 0.2V, other inputs = 0~3V	-L		100	μA
		2) $\bar{S}_1$ V <sub>CC</sub> - 0.2V, S <sub>2</sub> V <sub>CC</sub> - 0.2V other inputs = 0~3V	-LL	0.3	20 (Note 7)	

Note7: I<sub>CC (PD)</sub> = 1μA in case of Ta = 25°C

**(2) TIMING REQUIREMENTS** (Ta = -40~85°C, unless otherwise noted)

Symbol	Parameter	Test conditions	Limits			Unit
			Min	Typ	Max	
t <sub>su (PD)</sub>	Power down set up time		0			ns
t <sub>rec (PD)</sub>	Power down recovery time		5			ms

**(3) POWER DOWN CHARACTERISTICS**

**$\bar{S}_1$  control mode**

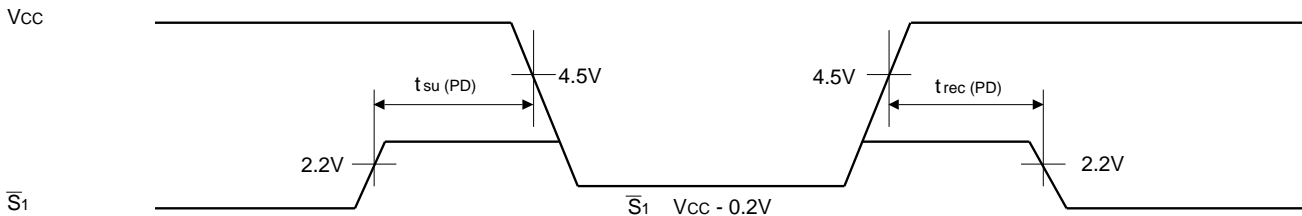

**S<sub>2</sub> control mode**

