

CXK5T81000ATM/AYM/AM -10LLX/12LLX

131072-word × 8-bit High Speed CMOS Static RAM Preliminary

Description

The CXK5T81000ATM/AYM/AM is a high speed CMOS static RAM organized as 131072-words by 8-bits.

Special feature are low power consumption and high speed.

The CXK5T81000ATM/AYM/AM is a suitable RAM for portable equipment with battery back up.

Features

- Extended operating temperature range:
 - 25 to +85°C
- Wide supply voltage range operation: 2.7 to 3.6V
- Fast access time:

		(Access time)	
3.0V operation	-10LLX	100ns	(Max.)
	-12LLX	120ns	(Max.)
3.3V operation	-10LLX	85ns	(Max.)
	-12LLX	100ns	(Max.)
- Low standby current: 28µA (Max.)
- Low data retention current: 24µA (Max.)
- Low voltage data retention: 2.0V (Min.)

• Package line-up

- CXK5T81000ATM/AYM
 - 8mm × 20mm 32 pin TSOP package
- CXK5T81000AM
 - 525mil 32 pin SOP package

Function

131072-word × 8-bit static RAM

Structure

Silicon gate CMOS IC

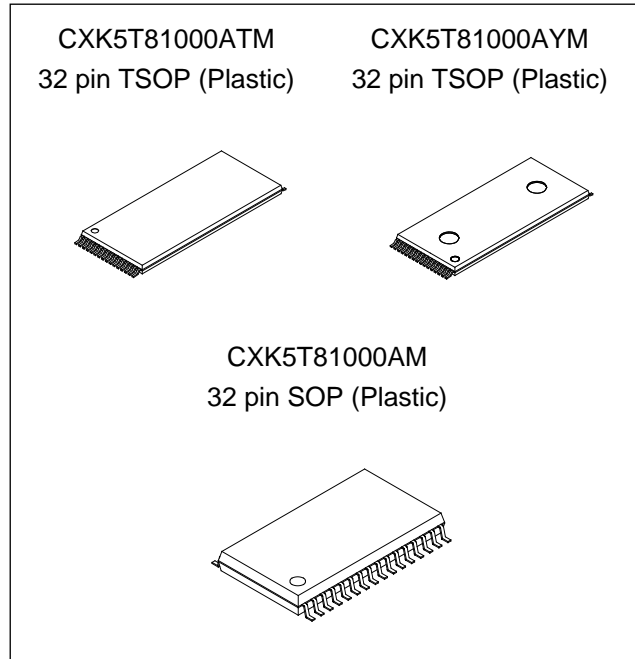

Block Diagram

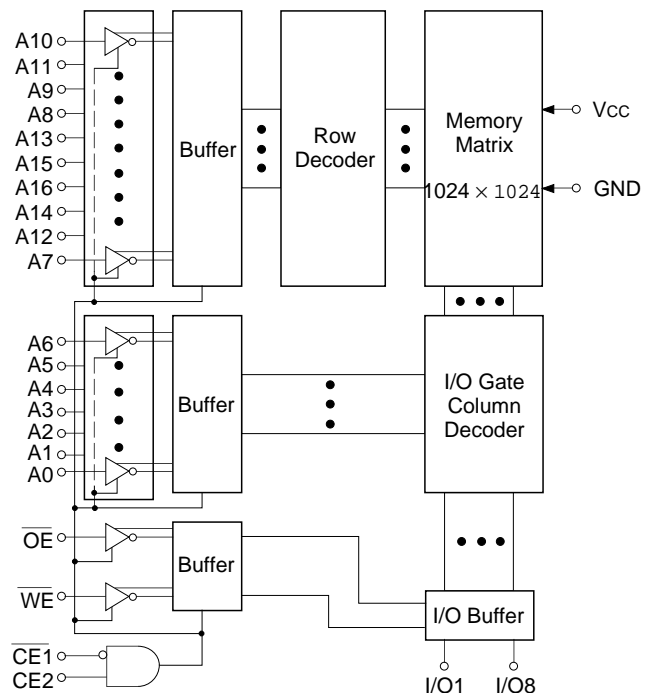

Sony reserves the right to change products and specifications without prior notice. This information does not convey any license by any implication or otherwise under any patents or other right. Application circuits shown, if any, are typical examples illustrating the operation of the devices. Sony cannot assume responsibility for any problems arising out of the use of these circuits.

Pin Configuration (Top View)

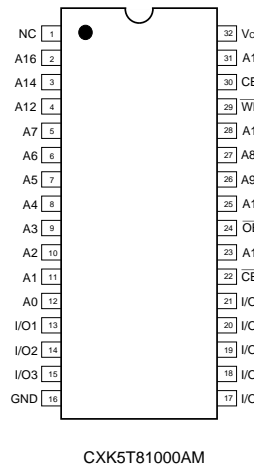
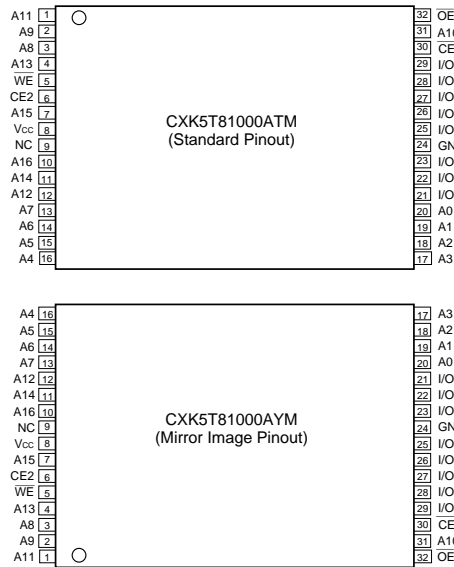

Pin Description

Symbol	Description
A0 to A16	Address input
I/O1 to I/O8	Data input output
$\overline{CE1}$, $\overline{CE2}$	Chip enable 1, 2 input
\overline{WE}	Write enable input
\overline{OE}	Output enable input
Vcc	Power supply
GND	Ground
NC	No connection

Absolute Maximum Ratings

(Ta = 25°C, GND = 0V)

Item	Symbol	Rating	Unit
Supply voltage	Vcc	-0.5 to +4.6	V
Input voltage	V _{IN}	-0.5*1 to Vcc + 0.5	V
Input and output voltage	V _{I/O}	-0.5*1 to Vcc + 0.5	V
Allowable power dissipation	P _D	0.7	W
Operating temperature	T _{opr}	-25 to +85	°C
Storage temperature	T _{stg}	-55 to +150	°C
Soldering temperature · time	T _{solder}	235 · 10	°C · s

*1 V_{IN}, V_{I/O} = -3.0V Min. for pulse width less than 50ns.

Truth Table

$\overline{CE1}$	CE2	\overline{OE}	\overline{WE}	Mode	I/O pin	Vcc Current
H	×	×	×	Not selected	High Z	ISB1, ISB2
×	L	×	×	Not selected	High Z	ISB1, ISB2
L	H	H	H	Output disable	High Z	Icc1, Icc2, Icc3
L	H	L	H	Read	Data out	Icc1, Icc2, Icc3
L	H	×	L	Write	Data in	Icc1, Icc2, Icc3

× : "H" or "L"

DC Recommended Operating Conditions

(Ta = -25 to +85°C, GND = 0V)

Item	Symbol	Vcc = 2.7 to 3.6V			Vcc = 3.3V ± 0.3V			Unit
		Min.	Typ.	Max.	Min.	Typ.	Max.	
Supply voltage	Vcc	2.7	3.3	3.6	3.0	3.3	3.6	V
Input high voltage	V _{IH}	2.4	—	Vcc + 0.3	2.2	—	Vcc + 0.3	
Input low voltage	V _{IL}	-0.3*1	—	0.4	-0.3*1	—	0.6	

*1 V_{IL} = -3.0V Min. for pulse width less than 50ns.

Electrical Characteristics

• DC Characteristics

(Vcc = 2.7 to 3.6V, GND = 0V, Ta = -25 to +85°C)

Item	Symbol	Test conditions	Min.	Typ.*1	Max.	Unit	
Input leakage current	I _{LI}	V _{IN} = GND to Vcc	-1	—	+1	μA	
Output leakage current	I _{LO}	$\overline{CE1} = V_{IH}$ or $CE2 = V_{IL}$ or $\overline{OE} = V_{IH}$ or $\overline{WE} = V_{IL}$ V _{I/O} = GND to Vcc	-1	—	+1	μA	
Operating power supply current	I _{CC1}	$\overline{CE1} = V_{IL}$, $CE2 = V_{IH}$ V _{IN} = V _{IH} or V _{IL} I _{OUT} = 0mA	—	1	3	mA	
Average operating current	I _{CC2}	Min. cycle duty = 100% I _{OUT} = 0mA	10LLX	—	25*2	35*3	mA
			12LLX	—	25	35	
	I _{CC3}	Cycle time 1μs duty = 100% I _{OUT} = 0mA CE1 ≤ 0.2V CE2 ≥ Vcc - 0.2V V _{IL} ≤ 0.2V V _{IH} ≥ Vcc - 0.2V	—	5	10	mA	
Standby current	I _{SB1}	CE2 ≤ 0.2V or { CE1 ≥ Vcc - 0.2V CE2 ≥ Vcc - 0.2V	-25 to +85°C	—	—	28	μA
			-25 to +70°C	—	—	14	
			+25°C	—	0.48	—	
	I _{SB2}	$\overline{CE1} = V_{IH}$ or $CE2 = V_{IL}$	—	0.12	1.4	mA	
Output high voltage	V _{OH}	I _{OH} = -2.0mA	2.4	—	—	V	
Output low voltage	V _{OL}	I _{OL} = 2.0mA	—	—	0.4	V	

*1 Vcc = 3.3V, Ta = 25°C

*2 I_{CC2} = 30mA for 3.3V operation (Vcc = 3.3V ± 0.3V)

*3 I_{CC2} = 40mA for 3.3V operation (Vcc = 3.3V ± 0.3V)

I/O capacitance

(Ta = 25°C, f = 1MHz)

Item	Symbol	Test conditions	Min.	Typ.	Max.	Unit
Input capacitance	C _{IN}	V _{IN} = 0V	—	—	8	pF
I/O capacitance	C _{I/O}	V _{I/O} = 0V	—	—	10	pF

Note) This parameter is sampled and is not 100% tested.

AC Characteristics

• **AC test conditions**

(Ta = -25 to +85°C)

Item	Conditions		
	V _{CC} = 2.7 to 3.6V	V _{CC} = 3.3V ± 0.3V	
Input pulse high level	V _{IH} = 2.4V	V _{IH} = 2.2V	
Input pulse low level	V _{IL} = 0.4V	V _{IL} = 0.6V	
Input rise time	tr = 5ns	tr = 5ns	
Input fall time	tf = 5ns	tf = 5ns	
Input and output reference level	1.4V	1.4V	
Output load conditions	-10LLX	C _L *1 = 100pF, 1TTL	C _L *1 = 30pF, 1TTL
	-12LLX	C _L *1 = 100pF, 1TTL	C _L *1 = 100pF, 1TTL

• Test circuit

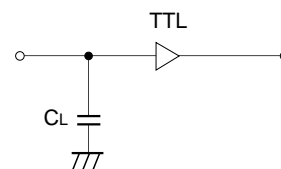

*1 C_L includes scope and jig capacitances.

• Read cycle ($\overline{WE} = "H"$)

Item	Symbol	V _{CC} = 2.7 to 3.6V				V _{CC} = 3.3V ± 0.3V				Unit
		-10LLX		-12LLX		-10LLX		-12LLX		
		Min.	Max.	Min.	Max.	Min.	Max.	Min.	Max.	
Read cycle time	t _{RC}	100	—	120	—	85	—	100	—	ns
Address access time	t _{AA}	—	100	—	120	—	85	—	100	ns
Chip enable access time ($\overline{CE1}$)	t _{CO1}	—	100	—	120	—	85	—	100	ns
Chip enable access time (CE2)	t _{CO2}	—	100	—	120	—	85	—	100	ns
Output enable to output valid	t _{OE}	—	50	—	60	—	40	—	50	ns
Output hold from address change	t _{OH}	10	—	10	—	10	—	10	—	ns
Chip enable to output in low Z ($\overline{CE1}$, CE2)	t _{LZ1} t _{LZ2}	10	—	10	—	10	—	10	—	ns
Output enable to output in low Z (\overline{OE})	t _{OLZ}	5	—	5	—	5	—	5	—	ns
Chip disable to output in high Z ($\overline{CE1}$, CE2)	t _{HZ1} *1 t _{HZ2} *1	—	40	—	40	—	35	—	40	ns
Output disable to output in high Z (\overline{OE})	t _{OHZ} *1	—	35	—	35	—	30	—	35	ns

*1 t_{HZ1}, t_{HZ2} and t_{OHZ} are defined as the time required for outputs to turn to high impedance state and are not referred to as output voltage levels.

• Write cycle

Item	Symbol	V _{CC} = 2.7 to 3.6V				V _{CC} = 3.3V ± 0.3V				Unit
		-10LLX		-12LLX		-10LLX		-12LLX		
		Min.	Max.	Min.	Max.	Min.	Max.	Min.	Max.	
Write cycle time	t _{WC}	100	—	120	—	85	—	100	—	ns
Address valid to end of write	t _{AW}	80	—	100	—	70	—	80	—	ns
Chip enable to end of write	t _{CW}	80	—	100	—	70	—	80	—	ns
Data to write time overlap	t _{DW}	40	—	50	—	35	—	40	—	ns
Data hold from write time	t _{DH}	0	—	0	—	0	—	0	—	ns
Write pulse width	t _{WP}	70	—	70	—	60	—	70	—	ns
Address setup time	t _{AS}	0	—	0	—	0	—	0	—	ns
Write recovery time (\overline{WE})	t _{WR}	0	—	0	—	0	—	0	—	ns
Write recovery time ($\overline{CE1}$, CE2)	t _{WR1}	0	—	0	—	0	—	0	—	ns
Output active from end of write	t _{OW}	5	—	5	—	5	—	5	—	ns
Write to output in high Z	t _{WHZ} *2	—	40	—	40	—	35	—	40	ns

*2 t_{WHZ} is defined as the time required for outputs to turn to high impedance state and is not referred to as output voltage level.

Timing Waveform

- Read cycle (1) : $\overline{CE1} = \overline{OE} = V_{IL}$, $CE2 = V_{IH}$, $\overline{WE} = V_{IH}$

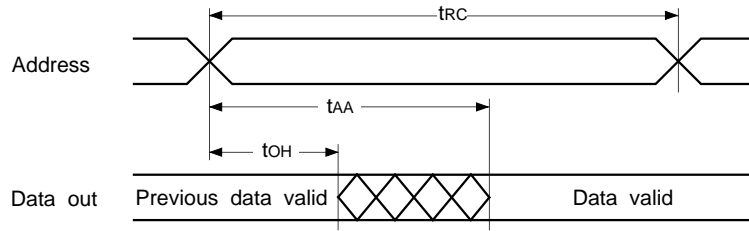

- Read cycle (2) : $\overline{WE} = V_{IH}$

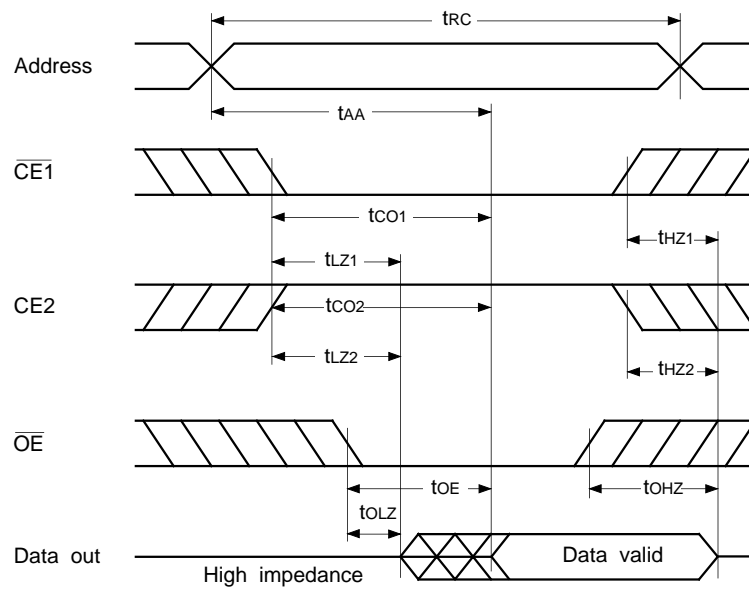

• Write cycle (1) : \overline{WE} control

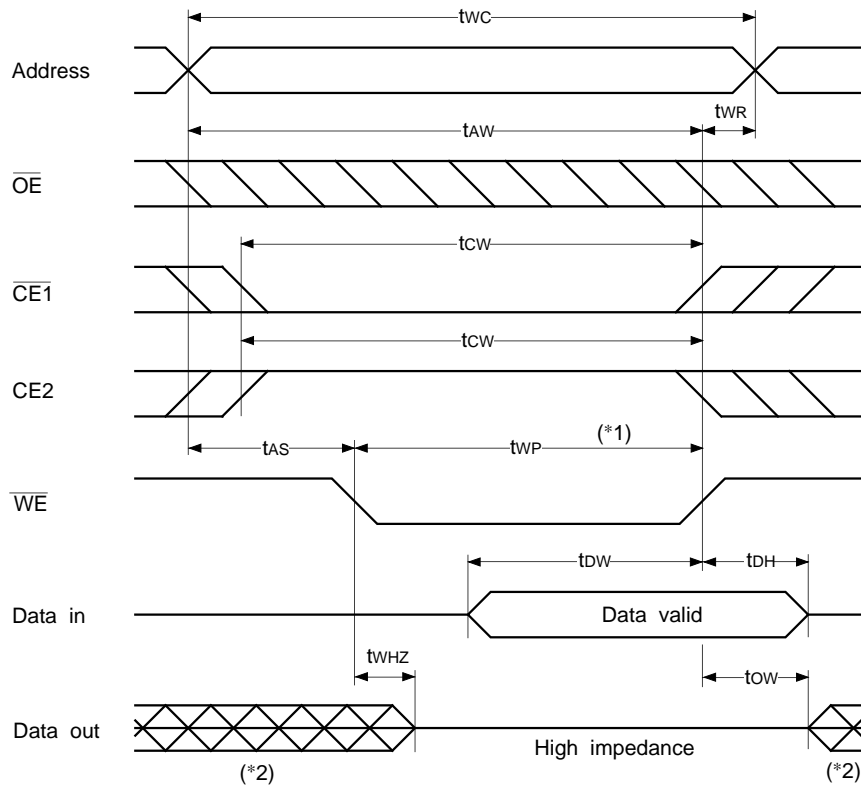

• Write cycle (2) : $\overline{CE1}$ control

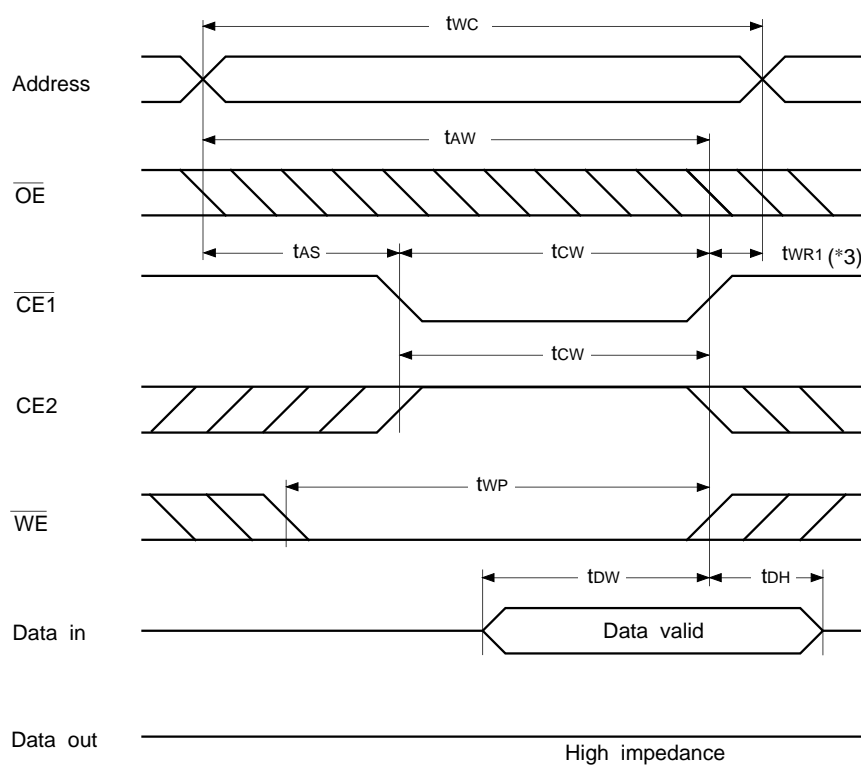

• Write cycle (3) : CE2 control

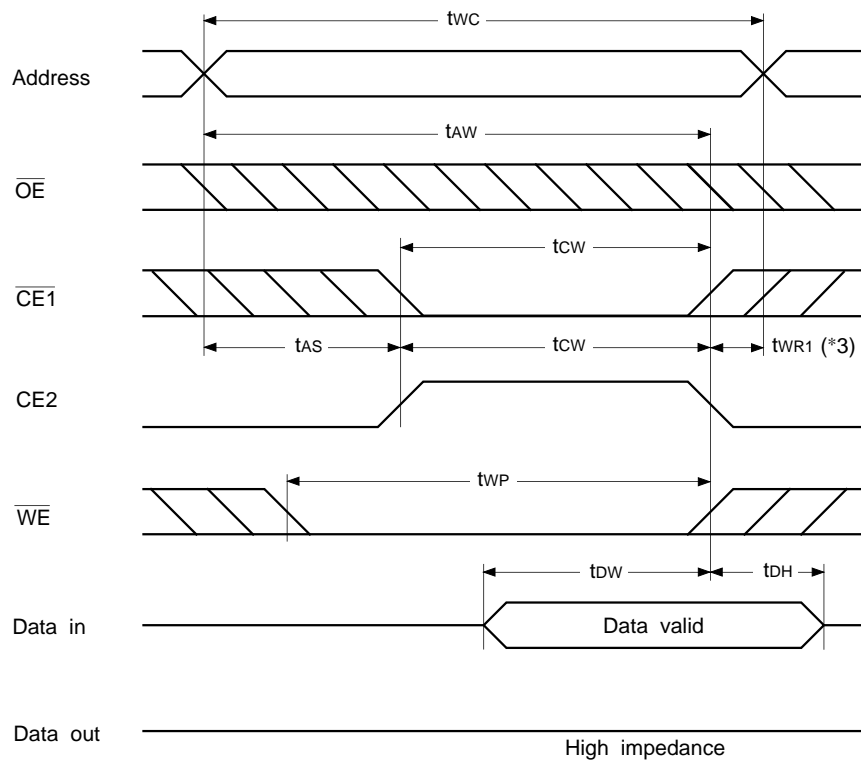

*1 Write is executed when both $\overline{CE1}$ and \overline{WE} are at low and CE2 is at high simultaneously.

*2 Do not apply the data input voltage of the opposite phase to the output while I/O pin is in output condition.

*3 t_{WR1} is tested from either the rising edge of $\overline{CE1}$ or the falling edge of CE2, whichever comes earlier, until the end of the write cycle.

Data retention waveform

• Low supply voltage data retention waveform (1) ($\overline{CE1}$ control)

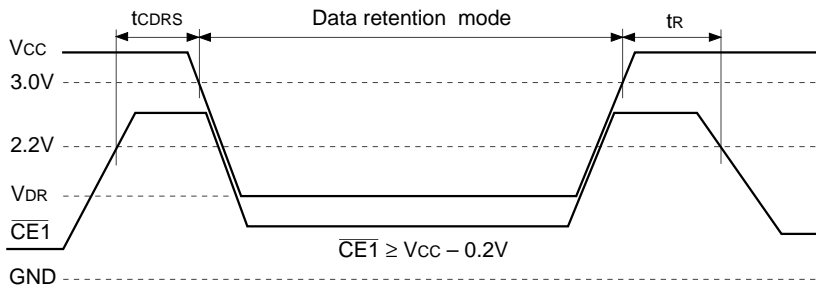

• Low supply voltage data retention waveform (2) (CE2 control)

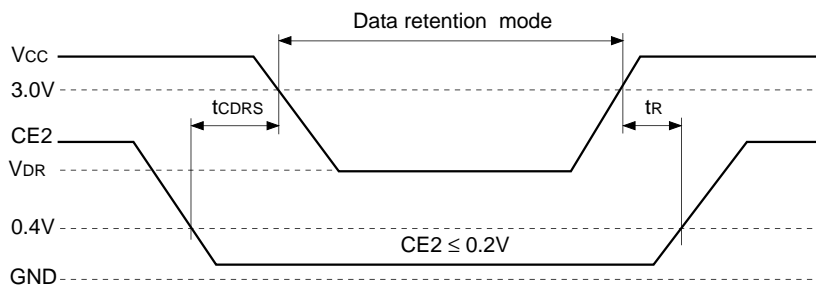

Data Retention Characteristics

($T_a = -25$ to $+85^\circ\text{C}$)

Item	Symbol	Test conditions	Min.	Typ.	Max.	Unit	
Data retention voltage	V_{DR}	*1	2.0	—	3.6	V	
Data retention current	I_{CCDR1}	$V_{CC} = 3.0V^{*1}$	-25 to $+85^\circ\text{C}$	—	—	24	μA
			-25 to $+70^\circ\text{C}$	—	—	12	
			$+25^\circ\text{C}$	—	0.4	—	
	I_{CCDR2}	$V_{CC} = 2.0$ to $3.6V^{*1}$	—	0.48^{*2}	28	μA	
Data retention setup time	t_{CDRS}	Chip disable to data retention mode	0	—	—	ns	
Recovery time	t_R		5	—	—	ns	

*1 $\overline{CE1} \geq V_{CC} - 0.2V$, $CE2 \geq V_{CC} - 0.2V$ ($\overline{CE1}$ control) or $CE2 \leq 0.2V$ (CE2 control)

*2 $V_{CC} = 3.3V$, $T_a = 25^\circ\text{C}$

Package Outline Unit: mm

CXK5T81000ATM

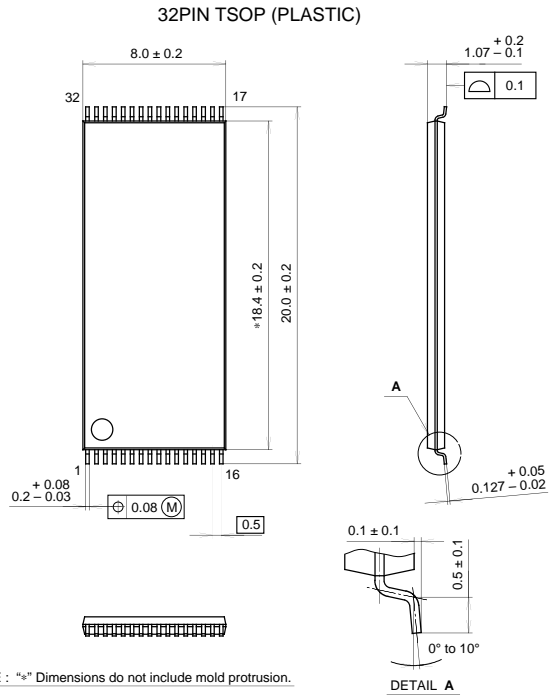

PACKAGE STRUCTURE

SONY CODE	TSOP-32P-L01
EIAJ CODE	TSOP032-P-0820
JEDEC CODE	

PACKAGE MATERIAL	EPOXY RESIN
LEAD TREATMENT	SOLDER PLATING
LEAD MATERIAL	42 ALLOY
PACKAGE WEIGHT	0.3g

CXK5T81000AYM

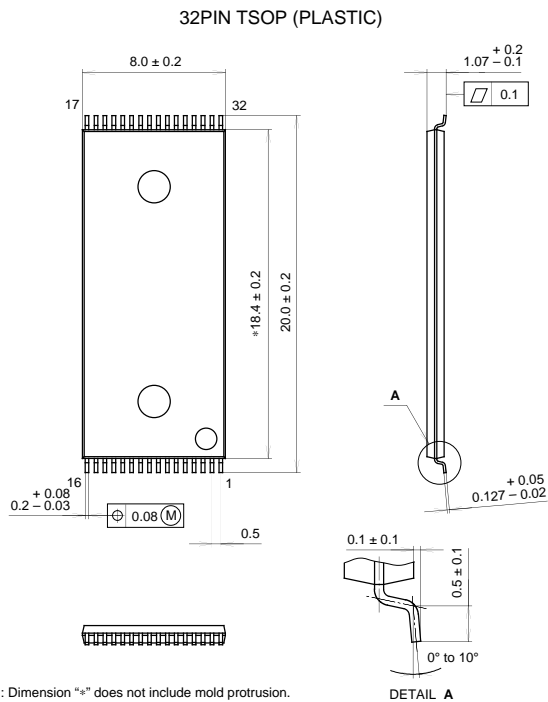

PACKAGE STRUCTURE

SONY CODE	TSOP-32P-L01R
EIAJ CODE	TSOP032-P-0820-B
JEDEC CODE	

PACKAGE MATERIAL	EPOXY RESIN
LEAD TREATMENT	SOLDER PLATING
LEAD MATERIAL	42 ALLOY
PACKAGE WEIGHT	0.3g

CXK5T81000AM

32PIN SOP (PLASTIC)

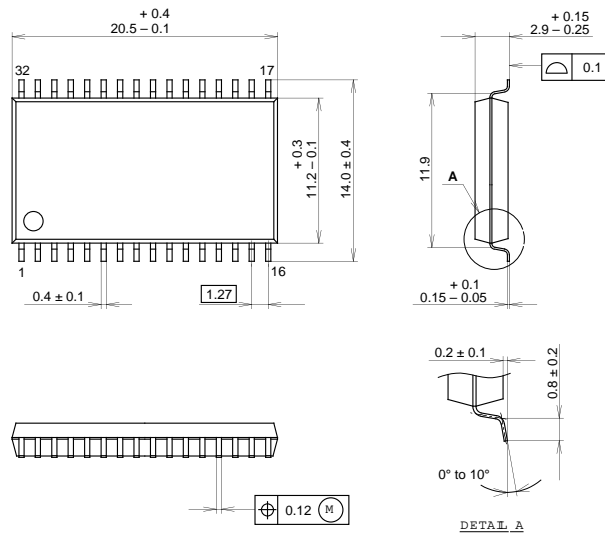

PACKAGE STRUCTURE

SONY CODE	SOP-32P-L02
EIAJ CODE	SOP032-P-0525
JEDEC CODE	—

PACKAGE MATERIAL	EPOXY RESIN
LEAD TREATMENT	SOLDER PLATING
LEAD MATERIAL	42 ALLOY
PACKAGE WEIGHT	1.2g