



PROGRAMMABLE SINGLE PHASE ENERGY METERING IC WITH TAMPER DETECTION

PRELIMINARY DATA

- INTEGRATED LINEAR VREGS TO SUPPLY THE DIGITAL AND ANALOG CORES
- ADVANCED BICMOS TECHNOLOGY FOR HIGH PERFORMANCE
- OTP FOR CALIBRATION AND CONFIGURATION
- INTEGRATED OSCILLATOR WITH EXTERNAL RESISTOR OR CRYSTAL
- MONITOR BOTH LIVE AND NEUTRAL FOR TAMPER DETECTION
- SIGMA DELTA 1st ORDER CONVERTER
- POWER SUPPLY CURRENT LESS THAN 6mA
- SUPPORT 50 ÷ 60 Hz – IEC 62052-11, IEC 62053-2X SPECIFICATION FOR CLASS 0.5 AC WATT METERS
- PRECISION VOLTAGE REFERENCE ON CHIP: 1.25 V AND 30 ppm/°C MAX
- TSSOP20 PACKAGE

DESCRIPTION

The STPM01 is designed for effective measurement of active energy in a power line system using the Rogowski and/or Shunt principle. This device can be implemented as a single chip 1-phase energy meter or as a peripheral measurement in a microprocessor based 1-phase or 3-phase energy meter.

The STPM01 consists, essentially, of two parts: the analog part and the digital part. The former, is composed by preamplifier and 1st order $\Sigma\Delta$ AD converter blocks, Bandgap voltage reference, Lowdrop voltage regulator and a pair of DC buffer, the latter, is composed by system control, clock generator, hard wired DSP and SPI interface. There is also a OTP block, which is controlled

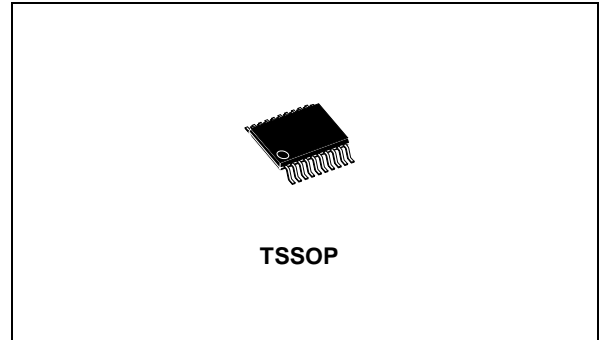

through the SPI by means of a dedicated command set. The configured bits are used for testing, configuration and calibration purpose.

From a pair of $\Sigma\Delta$ output signals coming from analog section, a DSP unit computes the amount of consummated active, reactive and apparent energy, RMS values of voltage and current value. The results of computation are available as pulse frequency and states on the digital outputs of the device or as data bits in a data stream, which can be read from the device by means of SPI interface. This system bus interface is used also during production testing of the device and/or for temporary or permanent programming of bits of internal OTP.

In the STPM01 the calibration is very easy: an output signal with pulse frequency proportional to energy is generated, this signal is used to enable the calibration of the energy meter.

When the device is fully configured and calibrated, a dedicated bit of OTP block, can be written permanently in order to prevent accidental entering into some test mode or changing any configuration.

Table 1: Order Codes

Type	Temperature Range	Package	Comments
STPM01	-40 to 85 °C	TSSOP20 (Tape & Reel)	2500 parts per reel

Figure 1: Pin Configuration

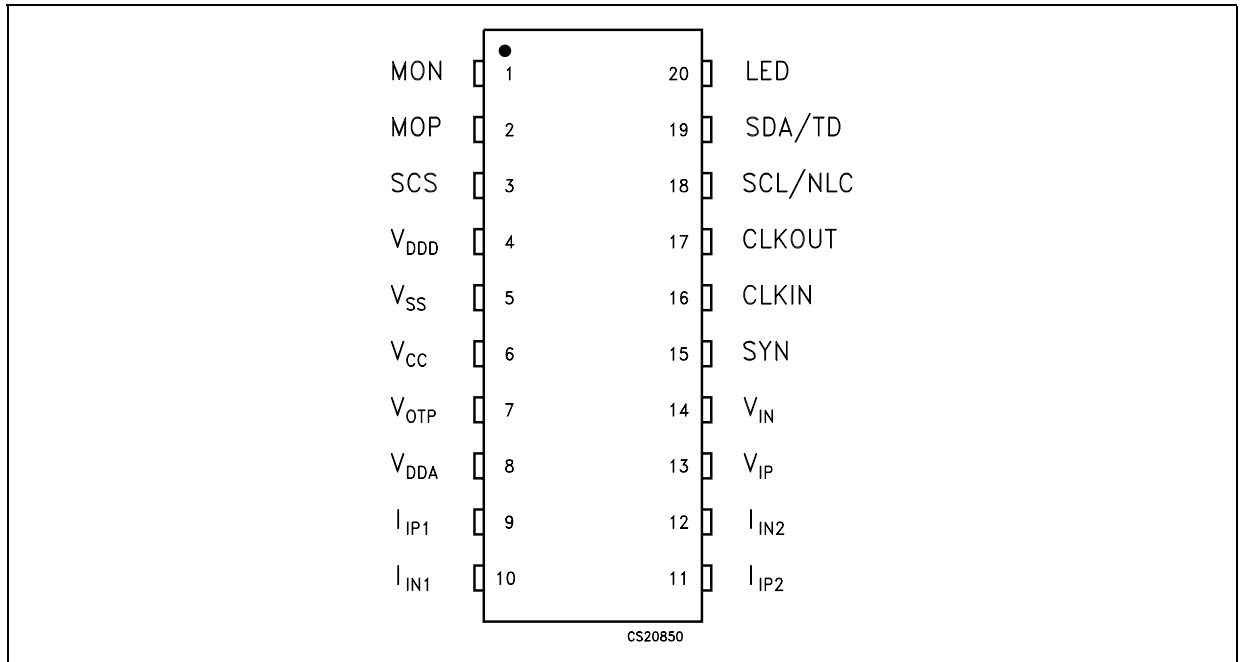

Table 2: Pin Description

PIN N°	SYMBOL	NAME AND FUNCTION
1, 2	MON, MOP	Motor pulse outputs. These outputs are used to driver in impulse counter or a stepper motor. They can also be used for reactive energy pulses LED indicator, or for output $\Sigma\Delta$ signal of analog current/voltage channel respectively, or for test mode i/o $\Sigma\Delta$ signal for analog current/ voltage channel respectively
3	SCS	Chip select - data transmission enable: a falling edge in this pin places the device in communication mode. Bringing SCS high places the serial bus in high impedance
4	V _{DDD}	Output of internal LowDrop regulator and power supply for digital core
5	V _{SS}	Ground: this pin provides a supply return and analog signal reference level.
6	V _{CC}	Positive Power Supply. Typically +5V
7	V _{OTP}	Power for programming OTP cells
8	V _{DDA}	Output of internal LowDrop regulator and power supply for analog core and OTP cells
9, 10	I _{IP1} , I _{IN1}	Analog input: +and – current (respectively) channel 1
11, 12	I _{IP2} , I _{IN2}	Analog input: +and – current (respectively) channel 2
13, 14	V _{IP} , V _{IN}	Analog input: +and – voltage (respectively) intended for use with the voltage transducer
15	SYN	Select data in or data out on SDA or Measurement latching for transmission or output for negative power
16	CLKIN	Input of internal crystal oscillator or input for external measure clock or current setting input for internal RC oscillator
17	CLKOUT	Output of internal RC or crystal oscillator
18	SCL/NLC	Serial clock input for the synchronous serial interface or for No Load Condition Led indicator
19	SDA/TD	Serial Data. Send and receiver data synchronous within CLK, or Tamper Detected Led indicator
20	LED	Signal for active energy pulses LED indicator or signal of analog current channel multiplex (available only when used as peripheral and if $\Sigma\Delta$ signal outputs are selected)

Figure 2: Block Diagram

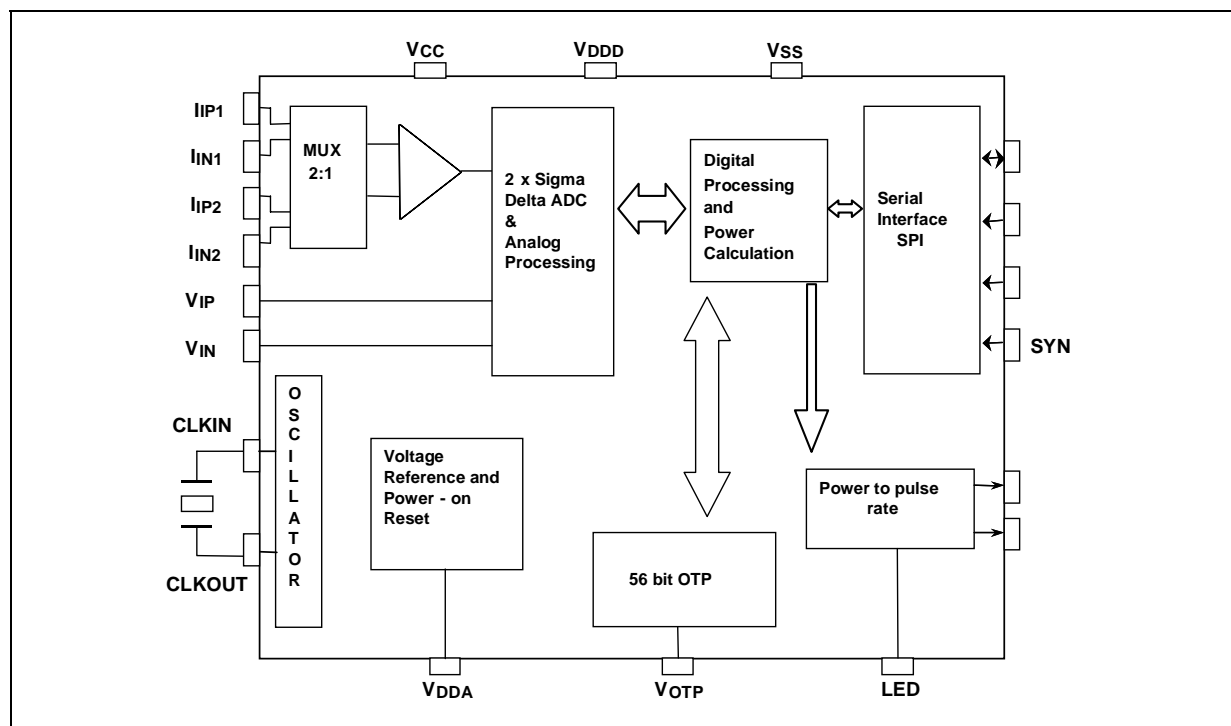

Table 3: Absolute Maximum Ratings

Symbol	Parameter	Value	Unit
V_{CC}	Supply Voltage	-0.3 to 6	V
I_{PIN}	Current on any pin	± 150	mA
T_A	Operating Temperature Range	-40 to +85	$^{\circ}C$

Absolute Maximum Ratings are those values beyond which damage to the device may occur. Functional operation under these condition is not implied.

Table 4: Electrical Characteristics (Typical values are at $T_A = 25^{\circ}C$, and $V_{CC} = 5V$)

Symbol	Parameter	Test Conditions	Min.	Typ.	Max.	Unit
V_{CC}	Supply Voltage Positive		3.165		5.5	V
I_{CC}	Supply Current Positive	4MHz, $V_{CC} = 5V$			4	mA
		8MHz, $V_{CC} = 5V$			6	
POR	Power On Reset on V_{CC}			2.5		V
V_{DDA}	Analog Supply Voltage	No Calibration		$3 \pm 5\%$		V
V_{DDD}	Digital core power supply			$1.5 \pm 5\%$		V
F	Nominal Line frequency			$50/60 \pm 5\%$		Hz
f_{clk}	Clock frequency		2		10	MHz
V_{PRG}	OTP Programming Level			14	20	V
I_{PRG}	OTP Programming Current			2.5		mA
t_{PRG}	OTP Programming Time		100		300	μs

Table 5: Analog Inputs Characteristics (IIP1, IIN1, IIP2, IIN2, VIP, VIN TO VSS)
(Typical values are at $T_A = 25^\circ\text{C}$, and $V_{CC} = 5\text{V}$)

Symbol	Parameter	Test Conditions	Min.	Typ.	Max.	Unit
V_{MAX}	Maximum Signal Levels		-0.2		0.2	V
f_{BAND}	Bandwidth			10		KHz
V_{OFF}	Offset				± 20	mV
Z_{IN}	Impedance of VIP, VIN		100		400	$K\Omega$
Z_{IN}	Impedance of IIP, IIN			100		$K\Omega$
G_{ER}	Gain Error			± 10		%
I_{LEAK}	Leakage Current		-1		1	μA

Table 6: Digital I/O Characteristics (SDA, CLKIN, CLKOUT, SCS, SYN, LED)
(Typical values are at $T_A = 25^\circ\text{C}$, and $V_{CC} = 5\text{V}$)

Symbol	Parameter	Test Conditions	Min.	Typ.	Max.	Unit
V_{IH}	Input High Voltage		$0.75V_{CC}$		$V_{CC}+0.2$	V
V_{IL}	Input Low Voltage		-0.3		$0.25V_{CC}$	V
V_{OH}	Output High Voltage	$I_O = -2\text{ mA}$	$V_{CC}-0.4$			V
V_{OL}	Output Low Voltage	$I_O = 2\text{ mA}$			0.4	V
I_{LEAK}	Pull up Current			15		μA
t_{TR}	Transition time	$C_L = 50\text{ pF}$			10	ns

Table 7: Power I/O Characteristics (MOP, MON) ($V_{CC} = 5\text{V}$, $V_{SS} = \text{GND}$, $T_A = -40$ to 85°C , unless otherwise specified. Typical values are at $T_A = 25^\circ\text{C}$)

Symbol	Parameter	Test Conditions	Min.	Typ.	Max.	Unit
V_{OH}	Output High Voltage	$I_O = -14\text{ mA}$	$V_{CC}-0.5$			V
V_{OL}	Output Low Voltage	$I_O = 14\text{ mA}$			0.5	V
t_{TR}	Transition time	$C_L = 50\text{ pF}$	5	10		μs

Table 8: Crystal Connection (Typical values are at $T_A = 25^\circ\text{C}$, and $V_{CC} = 5\text{V}$)

Symbol	Parameter	Test Conditions	Min.	Typ.	Max.	Unit
$V_{IH}(\text{CLKIN})$	High level input voltage on CLKIN		$0.8V_{DD}$		V_{DD}	V
$V_{IL}(\text{CLKIN})$	Low level input voltage on CLKIN		0		$0.3V_{DD}$	V
I_I	Input current on CLKIN				± 1	μA
R_P	External Resistor		1		4	$M\Omega$
C_P	External Capacitors			22		pF
f_{CLKOUT}	Nominal frequency		4	4.194		MHz
			8	8.192		
I_{CLKIN}	Settling current (RC Oscillator)	$f_{\text{CLKOUT}} = 4\text{ MHz}$	40		60	μA

Table 9: On Chip Reference (Typical values are at $T_A = 25^\circ\text{C}$, and $V_{CC} = 5\text{V}$)

Symbol	Parameter	Test Conditions	Min.	Typ.	Max.	Unit
T_C	Temperature Coefficient	After Calibration		30	50	ppm/ $^\circ\text{C}$
V_{GB}	Analog Reference Voltage			1.23 \pm 1%		V

Table 10: SPI Interface Timings (Typical values are at $T_A = 25^\circ\text{C}$, and $V_{CC} = 5\text{V}$)

Symbol	Parameter	Test Conditions	Min.	Typ.	Max.	Unit
F_{SCLKr}	Data read speed				32	MHz
F_{SCLKw}	Data write speed				100	KHz
t_{DS}	Data setup time		20			ns
t_{DH}	Data hold time		0			ns
t_{ON}	Data driver on time				20	ns
t_{OFF}	Data driver off time				20	ns
t_{SYN}	SYN active width		$2/f_{CLK}$			ns

TSSOP20 MECHANICAL DATA

DIM.	mm.			inch		
	MIN.	TYP	MAX.	MIN.	TYP.	MAX.
A			1.2			0.047
A1	0.05		0.15	0.002	0.004	0.006
A2	0.8	1	1.05	0.031	0.039	0.041
b	0.19		0.30	0.007		0.012
c	0.09		0.20	0.004		0.0079
D	6.4	6.5	6.6	0.252	0.256	0.260
E	6.2	6.4	6.6	0.244	0.252	0.260
E1	4.3	4.4	4.48	0.169	0.173	0.176
e		0.65 BSC			0.0256 BSC	
K	0°		8°	0°		8°
L	0.45	0.60	0.75	0.018	0.024	0.030

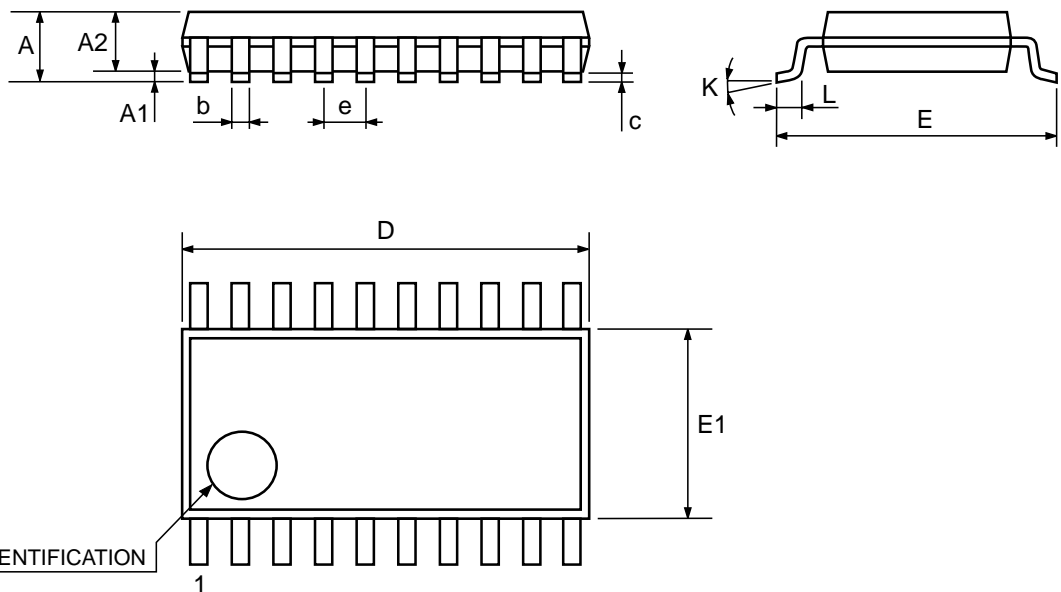

0087225C

Tape & Reel TSSOP20 MECHANICAL DATA

DIM.	mm.			inch		
	MIN.	TYP	MAX.	MIN.	TYP.	MAX.
A			330			12.992
C	12.8		13.2	0.504		0.519
D	20.2			0.795		
N	60			2.362		
T			22.4			0.882
Ao	6.8		7	0.268		0.276
Bo	6.9		7.1	0.272		0.280
Ko	1.7		1.9	0.067		0.075
Po	3.9		4.1	0.153		0.161
P	11.9		12.1	0.468		0.476

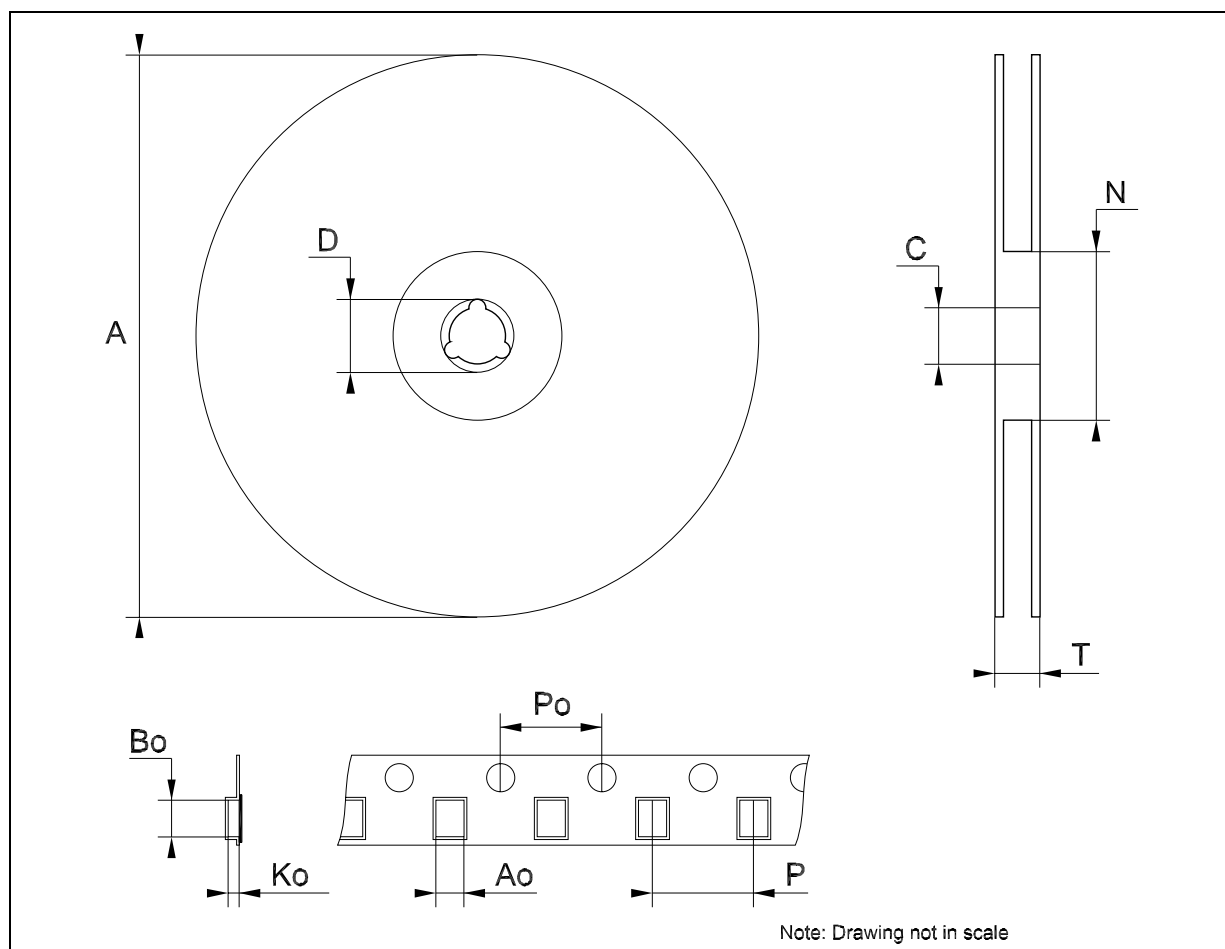

Table 11: Revision History

Date	Revision	Description of Changes
28-Sep-2004	1	Preliminary Data.

Information furnished is believed to be accurate and reliable. However, STMicroelectronics assumes no responsibility for the consequences of use of such information nor for any infringement of patents or other rights of third parties which may result from its use. No license is granted by implication or otherwise under any patent or patent rights of STMicroelectronics. Specifications mentioned in this publication are subject to change without notice. This publication supersedes and replaces all information previously supplied. STMicroelectronics products are not authorized for use as critical components in life support devices or systems without express written approval of STMicroelectronics.

The ST logo is a registered trademark of STMicroelectronics

All other names are the property of their respective owners

© 2004 STMicroelectronics - All Rights Reserved

STMicroelectronics group of companies

Australia - Belgium - Brazil - Canada - China - Czech Republic - Finland - France - Germany - Hong Kong - India - Israel - Italy - Japan - Malaysia - Malta - Morocco - Singapore - Spain - Sweden - Switzerland - United Kingdom - United States of America

www.st.com