

**W81386D**  
**Winbond USB Interface**  
**MS/SD/MMC Reader**

## W81386D Data Sheet Revision History

	Pages	Dates	Version	Web Version	Main Contents
1		07/2001	0.50		First published.
2					
3					
4					
5					
6					
7					
8					
9					
10					

Please note that all data and specifications are subject to change without notice. All the trademarks of products and companies mentioned in this data sheet belong to their respective owners.

### **LIFE SUPPORT APPLICATIONS**

These products are not designed for use in life support appliances, devices, or systems where malfunction of these products can reasonably be expected to result in personal injury. Winbond customers using or selling these products for use in such applications do so at their own risk and agree to fully indemnify Winbond for any damages resulting from such improper use or sales.

## Table of Content

<b>1. GENERAL DESCRIPTION .....</b>	<b>1</b>
<b>2. FEATURES .....</b>	<b>1</b>
<b>3. PIN CONFIGURATION .....</b>	<b>2</b>
<b>4. PIN DESCRIPTIONS .....</b>	<b>3</b>
<b>5. BLOCK DIAGRAM.....</b>	<b>6</b>
<b>6. USB INTERFACE CIRCUIT .....</b>	<b>7</b>
<b>7. SERIAL EEPROM INTERFACE DESCRIPTION AND MODE SETTING .....</b>	<b>8</b>
7.1 The Data Format of Serial EEPROM .....	8
7.2 LED Indicator and Mode Setting (when SEM_CS = High) .....	10
<b>8. ELECTRICAL CHARACTERISTICS .....</b>	<b>12</b>
8.1 Maximum Ratings* .....	12
8.2 Recommended Operating Conditions .....	12
8.3 Power Supply Characteristics .....	12
8.4 Digital Characteristics.....	13
8.5 Timing Characteristics.....	13
<b>9. HOW TO READ THE TOP MARKING .....</b>	<b>16</b>
<b>10. PACKAGE DIMENSIONS.....</b>	<b>17</b>
<b>11. REFERENCE SCHEMATIC .....</b>	<b>18</b>



## PRELIMINARY

### 1. GENERAL DESCRIPTION

The W81386D is a high-integrated USB1.1 full-speed MS/SD/MMC reader controller. W81386D is an USB full-speed device, which can provide up to 12Mb/s data transfer rate. W81386D meets USB bus-powered device spec with embedded 5V-3.3V power regulator, external power adopter is no needed, and USB plug and play feature provides nice user experience. W81386D is a single chip solution with 48-pin LQFP streamline package, which can be easily integrated into PC, NB, or external peripheral device to implement MS/SD/MMC reader function.

### 2. FEATURES

- High integrated single chip solution
- Compliant with USB Specification Version 1.1
- Compliant with MS (Memory Stick™) Specification Version 1.3
- Compliant with SD (Secure Digital) Specification Version 1.0
- Compliant with MMC Specification Version 2.2
- USB bus-powered device compliant
- 6MHz clock input to eliminate EMI effect
- Optional serial EEPROM interface for vendor ID and product ID download
- USB full speed device with 12Mb/s transmitting rate
- Support suspend and resume function
- Remote wake up supported
- Two or three LED mode supported, to indicate power on, card insert, and data access with hardware setting selection
- Power saving mode supported
- Built-in 5V to 3.3V regulator
- Implement over current detection circuit for abnormal card insertion protection
- 48 pin LQFP package

### Ordering Information

Part Number	Package Type	Production Flow
W81386D	48-PIN LQFP	Commercial, 0°C to +70°C

## 3. PIN CONFIGURATION

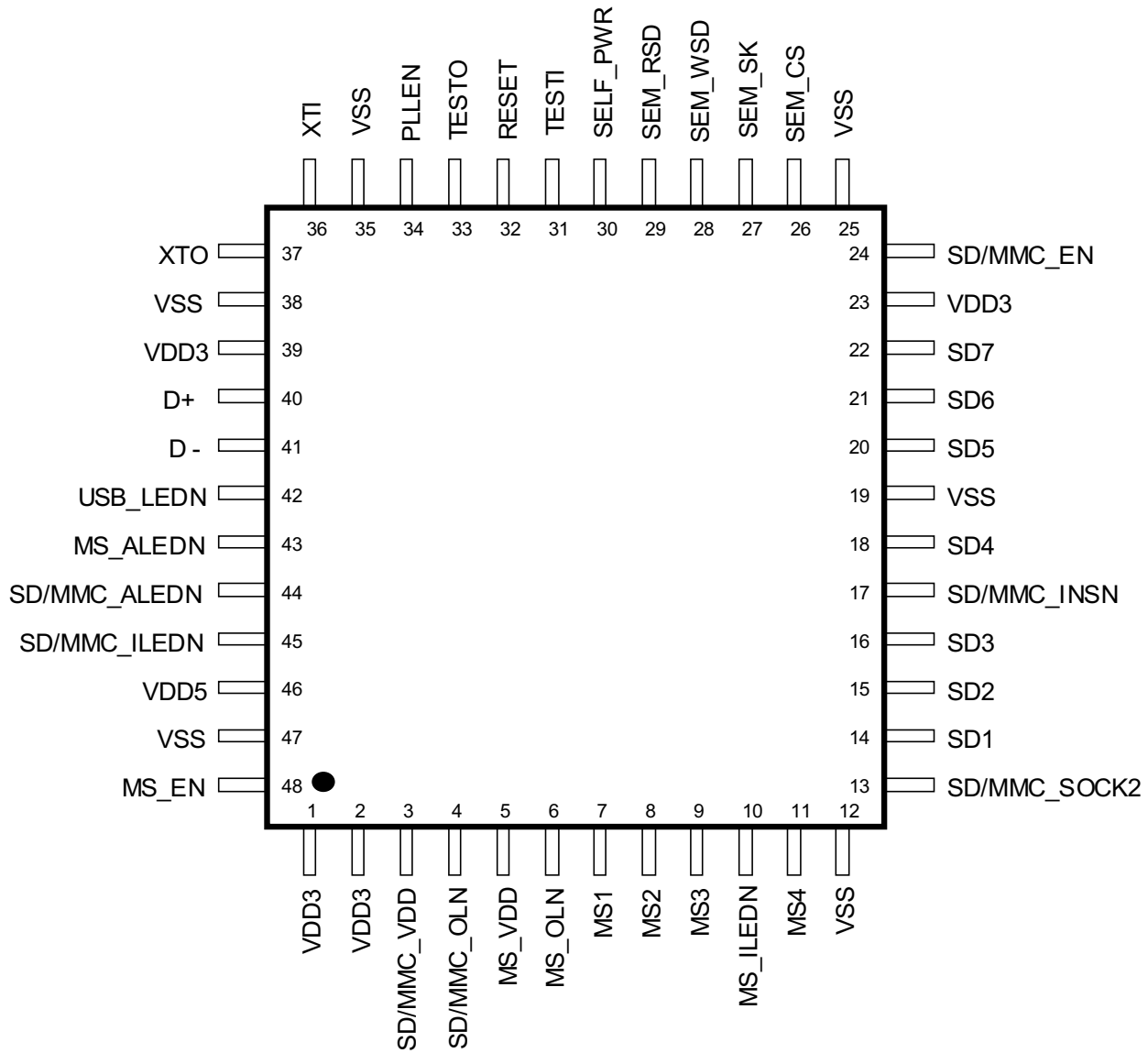

## 4. PIN DESCRIPTIONS

PIN	NAME	TYPE <sup>*1</sup>	DESCRIPTION
<b>MS Interface:</b>			
7	MS1	DO	Memory Stick connection pin #1
8	MS2	SDO/SDI	Memory Stick connection pin #2
9	MS3	DI	Memory Stick connection pin #3
11	MS4	DO	Memory Stick connection pin #4
5	MS_VDD	DO	Power output signal for Memory Stick card.
48	MS_EN	DI	Memory Stick enable pin <sup>*2</sup> . The description is at Note 2.
6	MS_OLN	SDI	Schmitt trigger input pin, used to detect the signal of over-loading from external over-current detect component. This pin is active low.
<b>SD/MMC Interface:</b>			
14	SD1	SDO/SDI	SD connection pin#1
15	SD2	SDO/SDI	SD connection pin#2
16	SD3	DO/DI	SD connection pin#3
18	SD4	DO	SD connection pin#4
20	SD5	SDO/SDI	SD connection pin#5
21	SD6	SDO/SDI	SD connection pin#6
22	SD7	DI	SD connection pin#7
3	SD/ MMC_VDD	DO	Power output signal for SD/ MMC memory card.
24	SD/ MMC_EN	DI	SD/MMC enable pin <sup>*2</sup> . The description is at Note 2.
4	SD/ MMC_OLN	SDI	Schmitt trigger input pin, used to detect the signal of over-loading from external over-current detect component. This pin is active low.
13	SD/MMC_SOCKET2	DI	SD/MMC socket mode setting. When use Socket1 <sup>*3</sup> , set this pin to 0 -- connect to GND. When use Socket2 <sup>*3</sup> , set this pin to 1 -- connect to VDD3.
17	SD/MMC_INSN	DI	SD/MMC card insert detection. Need external pull-up resistor to VDD3. And if use Socket2 <sup>*3</sup> , connect to card-detect pin of the socket.



PRELIMINARY

## 4. Pin Descriptions continued

PIN	NAME	TYPE <sup>*1</sup>	DESCRIPTION
<b>USB Interface:</b>			
40	D+	AIO	USB D plus signal.
41	D-	AIO	USB D minus signal.
<b>Crystal Driver:</b>			
6	XTI	DI	Clock driver input signal for 6MHz crystal, may be used as the external clock 48MHz(oscillator) input.
37	XTO	DO	Clock driver output signal.
34	PLLEN	DI	Internal PLL enable. When use 6MHz, set this pin to 0 -- connect to GND. When use 48MHz, set this pin to 1 -- connect to VDD3.
<b>Serial EEPROM Interface:</b>			
26	SEM_CS	DI/DO	DO: Serial EEPROM chip select. DI: Connect to VDD3 for default VID/PID setting.
27	SEM_SK	DO/DI	Serial EEPROM Serial Clock. The setting pin of LED indicate mode in default setting.
28	SEM_WSD	DO/DI	Serial EEPROM command Write Serial Data. The setting pin of LED indicate mode in default setting.
29	SEM_RSD	SDI	Serial EEPROM Read Serial Data. Remote wake up set pin in default setting
<b>LED indicator:</b>			
42	USB_LEDN	DO	LED indicator for USB port. (active low)
43	MS_ALEDN	DO	LED indicator for MS card accessing (active low)
10	MS_ILEDN	DO	LED indicator for MS card insert.(active low)
45	SD/MMC_ILEDN	DO	LED indicator for SD/ MMC card insert. (active low)
44	SD/ MMC_ALEDN	DO	LED indicator for SD/ MMC card accessing. (active low)
<b>Other Signal:</b>			
32	RESET	SDI	Reset input, hardware reset input, active high.
30	SELF_PWR	DI	If it is high, SELF_PWR configured, pull low.
31	TESTI	DI	Test Input, must left open when in normal operation.
33	TESTO	DO	Test output, must float in normal operation.



**PRELIMINARY**

4. Pin Descriptions continued

PIN	NAME	TYPE <sup>*1</sup>	DESCRIPTION
<b>Power:</b>			
46	VDD5	PI	Power 5V.
1, 2, 23, 39	VDD3	PO	Embedded regulator power 3.3V output, need to connect a 10uF capacitor. This pin should not provide power to external components or circuit.
12, 19, 25, 35, 38, 47	VSS	G	Ground.

Note 1: Type: AI is Analog Input, AO is Analog Output, DI is Digital Input, DO is Digital Output, PI is Power Input, PO is Power Output, G is Ground and S is Schmitt trigger.

Note 2: MS\_EN and SD/MMC\_EN are mode enable pins.

MS_EN	SD/MMC_EN	Description
Low	High	Enable Memory Stick only.
High	Low	Enable SD/MMC only.
Low	Low	Enable both Memory Stick and SD/MMC. And LED indicator mode is individual mode. (Sec. 7.2)
High	High	Enable both Memory Stick and SD/MMC. And LED indicator mode is sharing mode. (Sec. 7.2)

Note 3:Socket1 means a SD/MMC card socket, which is without additional card detect switch.

Socket2 means a SD/MMC card socket, which is with additional card detect switch.



5. BLOCK DIAGRAM

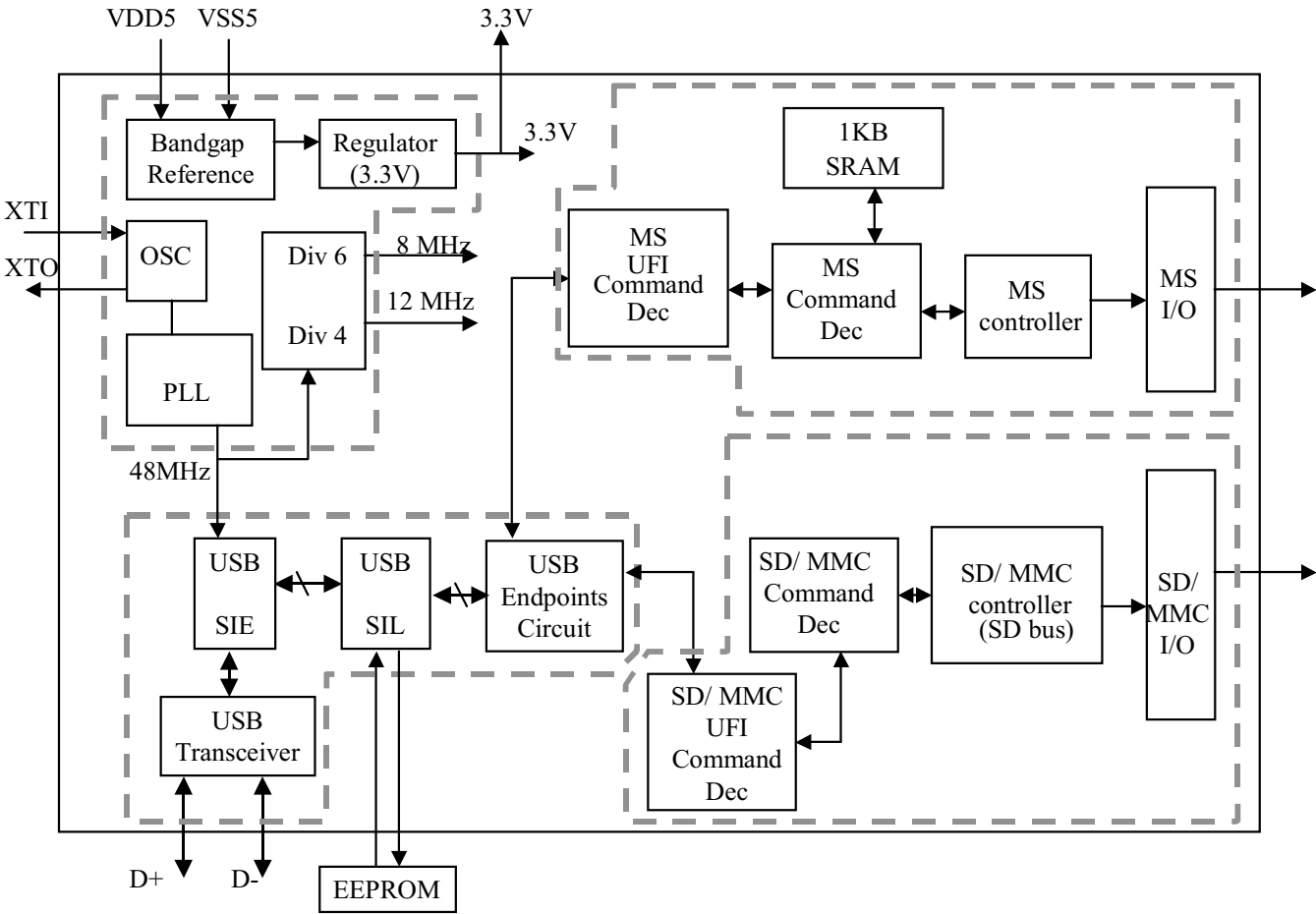

Fig. 5-1 Block Diagram of W81386

### 6. USB INTERFACE CIRCUIT

USB interface circuit includes USB transceiver, USB serial interface engine (SIE), USB transaction control logic, USB endpoint control logic and endpoint circuit. The USB transaction control logic and USB endpoint control logic also called USB serial interface logic (SIL). Figure 6-1 shows the detail block diagram of USB interface circuit.

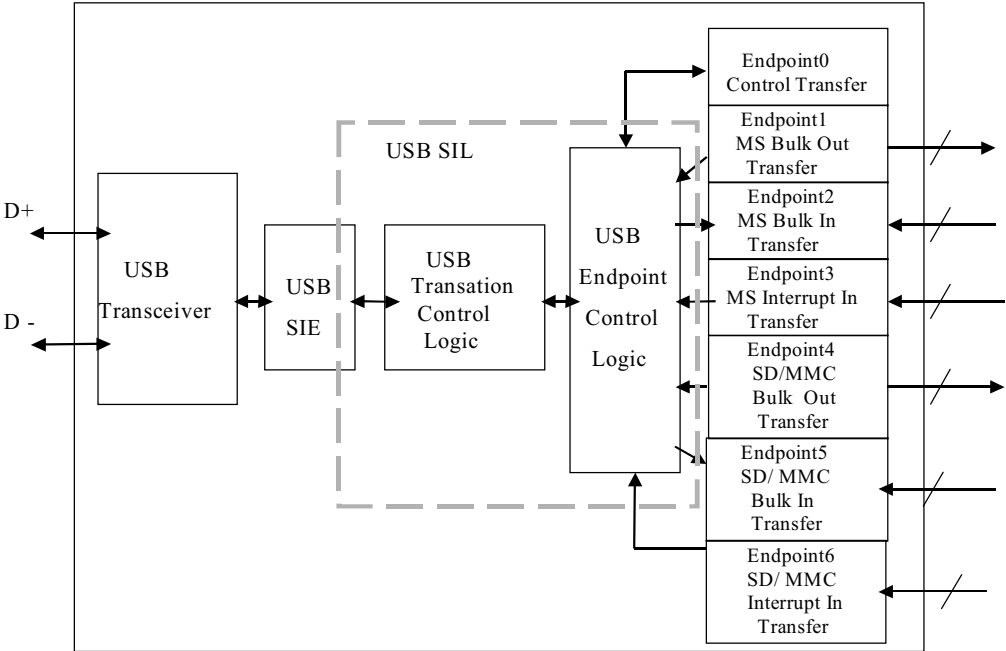

Fig6-1 Block Diagram of USB Interface Circuit

## 7. SERIAL EEPROM INTERFACE DESCRIPTION AND MODE SETTING

The serial EEPROM (93C46) is optional for some of parameter setting. If SEM\_CS = high(short to VDD3) is used to set the default parameter mode (like default USB VID/PID). And the LED indicator mode set at SEM\_SK and SEM\_WSD pins. If the pin SEM\_CS is Open and the serial EEPROM is existent, the parameters should load from the serial EPPROM.

### 7.1 The Data Format of Serial EEPROM

If the parameter is read from serial EEPROM, the LED indicator mode is set in one byte data stored in the EEPROM.

#### Data record in 93C46 for setting:

- Only one set of VID, PID, power setting, string descriptor, and LED setting in the 93C46.

Address*	Content	Description
0	iVender / Device Desc, Low-byte.	Vender ID.
1	iVender / Device Desc, High-byte.	Vender ID.
2	iProduct / Device Desc, Low-byte.	Product ID.
3	iProduct / Device Desc, High-byte.	Product ID.
4	bcdDevice / Device Desc, Low-byte.	Device releaseNo. in bcd code.
5	bcdDevice / Device Desc, High-byte.	Device releaseNo. in bcd code.
6	bmAttribute / Configuration Desc.	Bit7: Reserved and must set 1. Bit6: Self Powered. Bit5: Remote wake up enable. Bit[4:0]: Reserved.
7	MaxPower / Configuration Desc.	Maximum Power consumption = n x 2 mA.
8	USB iProduct and LED setting.	Bit [2:1] is the same state setting of SEM_SK and SEM_WSD when default setting during reset. Bit 7 = 1 is enable USB iProduct string. Bit 7 = 0 is disable USB iProduct string.
9	LED flash period setting.	Fine tune the access LED flash periods, the maximum value is about 1 Hz.
10	String length.(must set less than or equal to 48)	String length of USB iProduct string,the maximum string length is 46 characters
11	0x00	Must be 0x00.
12	0x03.	Must 0x03 value.

## PRELIMINARY

<b>Address*</b>	<b>Content</b>	<b>Description</b>
13~57	String content.	Each character use two bytes, 45 characters at most in the string. One byte of data 00 between each character should not write in the 93C46, the data 00 may be filled in the unused content if the number of characters is less than 45.
58~65	Reserve	Reserve
66~81	UFI response data (Product Identification).	16 bytes Product Identification of UFI inquiry data, independent of MS interface or SD/MMC interface. The order should be reverse



PRELIMINARY

## 7.2 LED Indicator and Mode Setting (when SEM\_CS = High)

The LED driver outputs are all active low, and use 5V VDD for the LED power. It should avoid the internal regulator to drive LEDs.

USB\_LEDN, MS\_ALEDN and SD/MMC\_ALEDN can be use in two LED indicate mode or three LED indicate mode. If SEM\_CS short to VDD3 is used to set the default parameter mode, the LED indicate mode also set at SEM\_SK and SEM\_WSD pins during reset. SEM\_SK = Low (open) is 3\_LED mode, SEM\_SK = High(short to VDD3) is 2\_LED mode. The SEM\_WSD is effective in 3\_LED mode, ALED will not flash when SEM\_WSD = Low (open) ALED will flash when SEM\_WSD = High (short to VDD3).

### Mode setting table:

SEM_CS	SEM_SK	SEM_WSD	SEM_RSD	Function
1	0	0	X	Default VID/PID and string descriptor, 3_LED and ALED no flash.
1	0	1	X	Default VID/PID and string descriptor, 3_LED and ALED flash.
1	1	X	X	Default VID/PID and string descriptor, 2_LED and ALED flash.
1	X	X	0	Default VID/PID and string descriptor, remote wake up enable.
1	X	X	1	Default VID/PID and string descriptor, remote wake up disable.

\* 1 is short to VDD3 and 0 is open on the board for SEM\_CS, SEM\_SK, SEM\_WSD. 0 for SEM\_RSD must be connected to GND.

### LED light state table:

State →	Power Down	USB Activity	Card Inserting		Card Accessing		
			3_LED	2_LED	3_LED	3_LED/flash	2_LED
USB_LEDN	Off	On	On	On	On	On	On
MS_ILEDN, SD/MMC_ILEDN	Off	Off	On	Off	On	On	Off
MS_ALEDN, SD/MMC_ALEDN	Off	Off	Off	On	On	Flash	Flash

## PRELIMINARY

### LED indicator setting:

When MS\_EN and SD\_EN can be selected by user (MS and SD/MMC for the customer), the MS\_EN and SD/MMC\_EN also can be select the LED driver:

- MS\_EN = high, SD/MMC\_EN = low: MS disable and SD/MMC enable, MS\_ALED off always.
- MS\_EN = low, SD/MMC\_EN = high: MS enable and SD/MMC disable, SD/MMC\_ILED and SD/MMC\_ALED off always.
- MS\_EN = low, SD/MMC\_EN = low: both MS enable and SD/MMC enable, MS\_ILED for MS card insert, MS\_ALED is for MS accessing, SD/MMC\_ILED and SD/MMC\_ALED are for SD/MMC card insert and accessing.
- MS\_EN = high, SD/MMC\_EN = high: both MS enable and SD/MMC enable, the MS card insert or SD/MMC card insert will reflect on the SD/MMC\_ILED status, the MS accessing or SD/MMC accessing will reflect on the SD/MMC\_ALED.

## 8. ELECTRICAL CHARACTERISTICS

### 8.1 Maximum Ratings\*

	Parameter	Symbol	Rating	Units
1	Supply Voltage with respect to $V_{AVSS}$	$V_{VDD5}$	-0.3 to 6	V
2	Supply Voltage with respect to $V_{VSS}$	$V_{VDD3}$	-0.3 to 6	V
3	Current at any pin other than supplies		0 to 10	mA
4	Storage Temperature	$T_{st}$	-65 to 150	°C

\*Exceeding these values may cause permanent damage

### 8.2 Recommended Operating Conditions

	Characteristics	Symbol	Rating	Unit
1	Operation Voltage (referenced to AVSS pin).	$V_{VDD5}$	4.0 to 5.5	V
2	Operation Voltage (referenced to VSS pin).	$V_{VDD3}$	3.6 to 3.6	V
5	Clock Frequency at XTI pin	$f_{XTL}$	6 or 48	MHz
6	Clock Frequency Tolerance	$\Delta f_C$	325 or 2500	PPM
7	Operation Temperature	$T_{op}$	0 to 70	°C

### 8.3 Power Supply Characteristics

	Parameter	Condition	Symbol	Min	Typ‡	Max	Units	Notes
1	Standby Supply Current	Power Supply	$I_Q$		378	500	uA	1
2	Operating Supply Current				34		mA	2

‡: Typical figure are at  $V_{VDD5} = 5.0V$  and temperature = 25 °C and are for design aid only, not guaranteed and not subject to production testing.

Note1: All input pins are  $V_{VDD}$  or  $V_{VSS}$ , configured as power down mode, output without loading and no clock input on the XTI pins.

## PRELIMINARY

Note2: 6MHz external clock input on the XTI pin, output without loading. For two interface, and access two cards at the same time.

### 8.4 Digital Characteristics

	Parameter	Condition	Symbol	Min	Typ‡	Max	Units	Notes
1	Output High Voltage	2mA load	V <sub>OH</sub>	0.9			VDD3	1
2	Output Low Voltage	2mA load	V <sub>OL</sub>			0.1	VDD3	1
3	Output High Voltage at CLK output	2mA load		0.9			VDD3	
4	Output Los Voltage at CLK output	2mA load				0.1	VDD3	
5	High Level Input Voltage		V <sub>IH</sub>	0.7			VDD3	
6	Low Level Input Voltage		V <sub>IL</sub>			0.3	VDD3	
7	Input Current		I <sub>in</sub>			1	uA	
8	Input Capacitance		C <sub>in</sub>		10		pF	

‡: Typical figure are at V<sub>VDD3</sub> = 3.3V and temperature = 25 °C and are for design aid only, not guaranteed and not subject to production testing.

Note1: All input pins except CLK output.

### 8.5 Timing Characteristics

	Parameter	Symbol	Min	Typ	Max	Units	Note
1	XTI	fXTI	6 or 48			MHz	1
2	XTI duty cycle		40%	-	60%	1 clock	
3	XTO delay time	fXTO <sub>d</sub>	-	-	5	ns	
<b>MS Serial Interface Signals referenced to MCLK(figure 8-1)</b>							
1	BS output delay	tBSd		3	5	ns	
2	SDIO output delay time	tSDIOd		5	8	ns	





PRELIMINARY

3	SDIO input setup time	tSDIOsu	10			ns	
4	SDIO input hold time	tSDIOh	5			ns	
<b>SD/MMC Serial Interface Signals referenced to SDCLK(figure 8-2)</b>							
1	Input CMD, DAT setup time	tCMDsu tDATsu	5			ns	
2	Input CMD, DAT hold time	tCMDh tDATh	5			ns	
3	Output CMD Delay time	tCMDd		7	14	ns	
4	Output DAT Delay time	tDATd		4	14	ns	

Note1: external clock input.

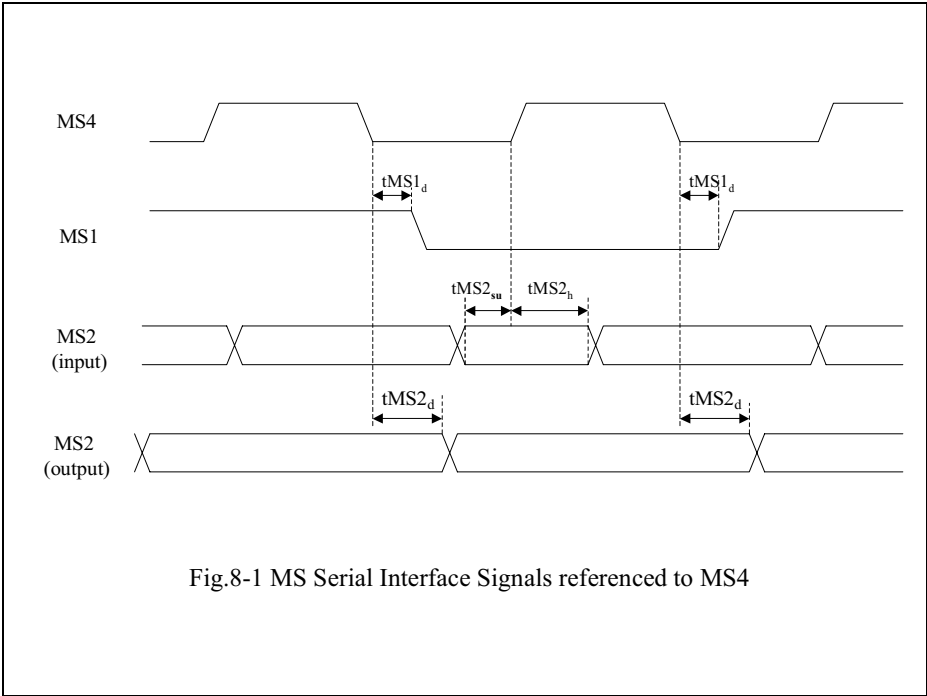
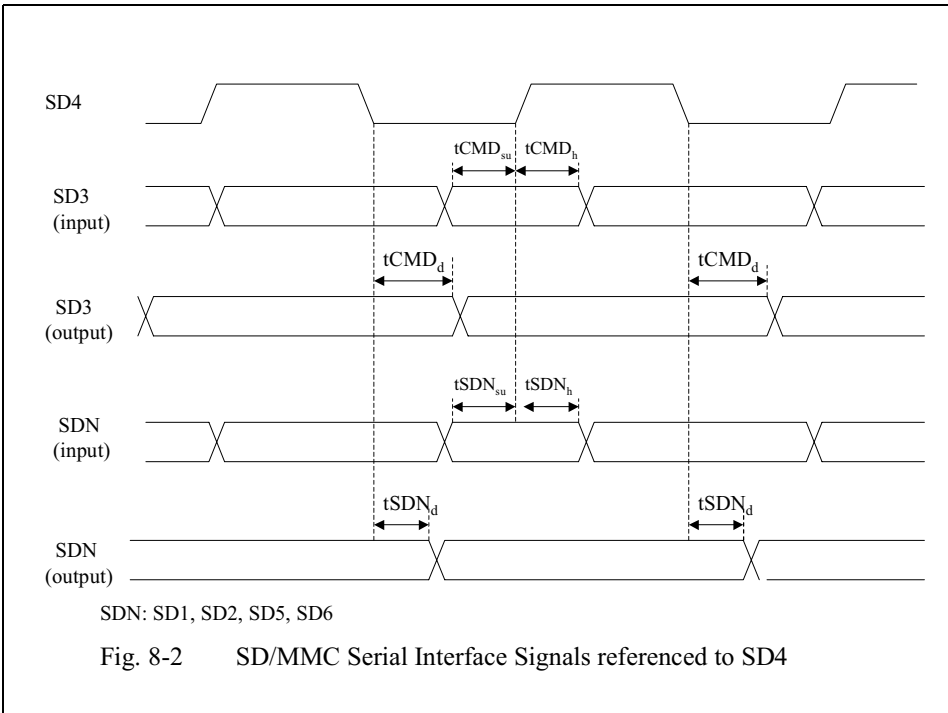

Fig.8-1 MS Serial Interface Signals referenced to MS4





PRELIMINARY

## 9. HOW TO READ THE TOP MARKING

The top marking of W81386D

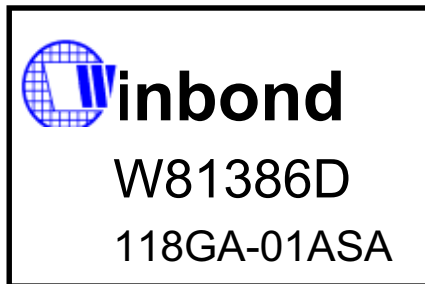

1st line: Winbond logo

2nd line: Part number of W81386D

3rd line: Tracking code 118 G A 01A SA

118: packages made in '01, week 18

G: assembly house ID; A means ASE, O means OSE, G means GR

A: IC revision; A means version A, B means version B

01A: for internal use

SA: for internal use

PRELIMINARY

## 10. PACKAGE DIMENSIONS

48-LQFP(7x7x1.4mm footprint 2.0mm)

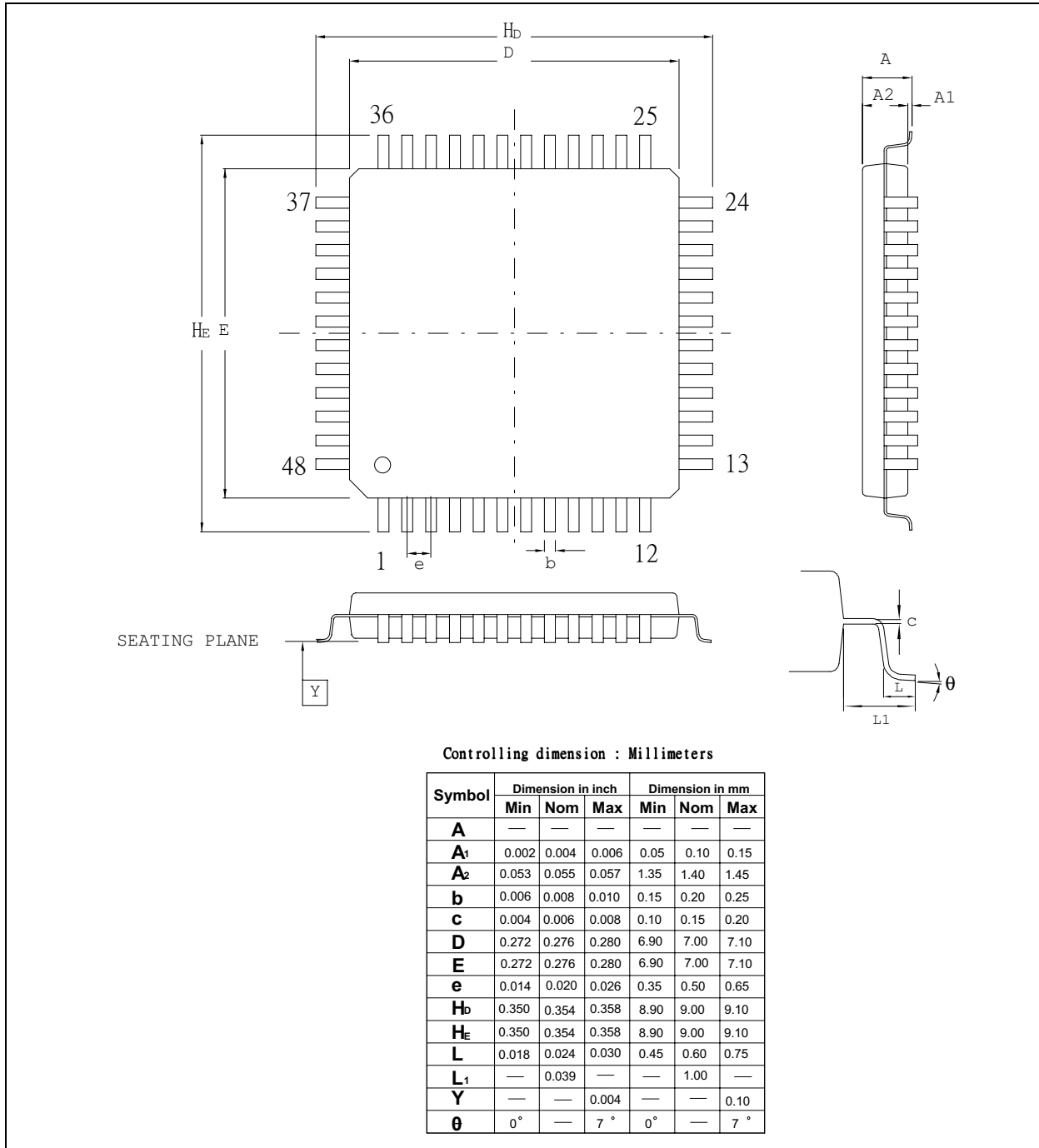

## 11. REFERENCE SCHEMATIC

Winbond USB MS/SD reader

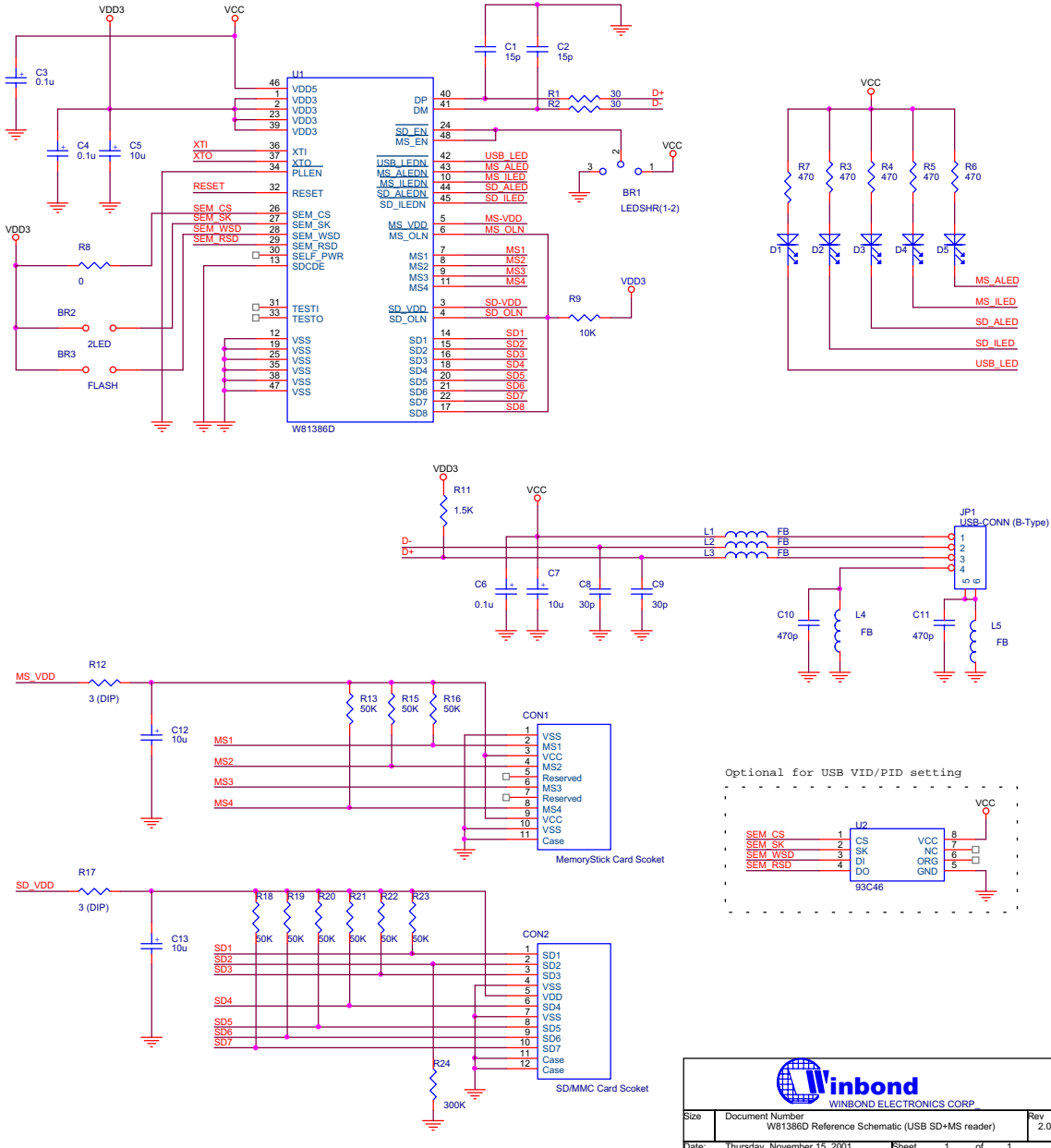

WINBOND ELECTRONICS CORP.		
Size	Document Number	Rev
	W81386D Reference Schematic (USB+MS reader)	2.0
Date:	Thursday, November 15, 2001	Sheet 1 of 1

### Winbond USB MS reader

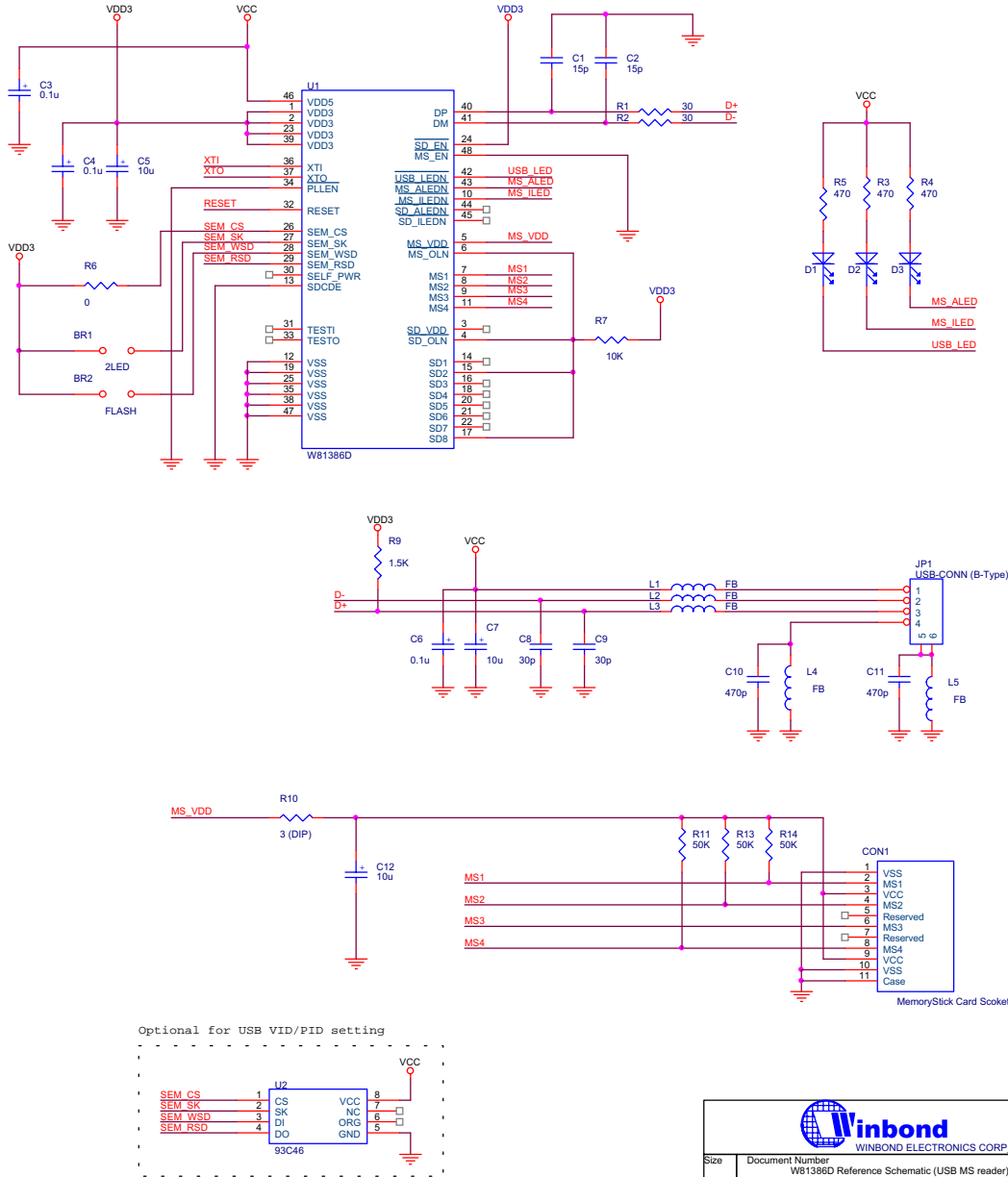

 WINBOND ELECTRONICS CORP.		
Size	Document Number	Rev
	W81386D Reference Schematic (USB MS reader)	2.0
Date:	Thursday, November 15, 2001	Sheet 1 of 1

# W81386D



PRELIMINARY

## Winbond USB SD reader

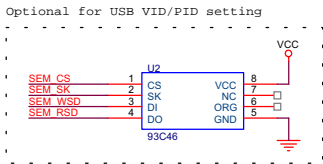
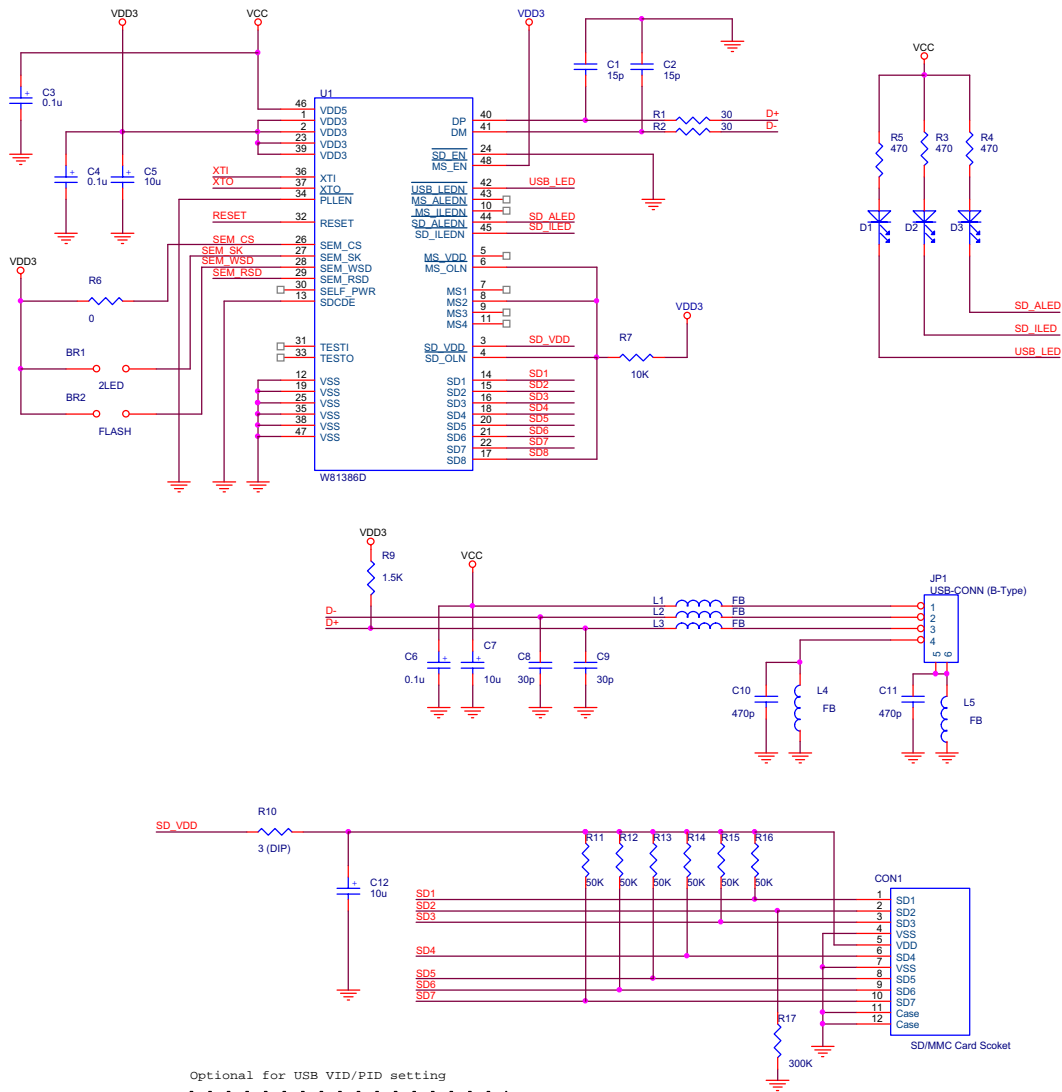

 WINBOND ELECTRONICS CORP.		
Size	Document Number	Rev
	W81386D Reference Schematic (USB SD reader)	2.0
Date:	Thursday, November 15, 2001	Sheet 1 of 1



**PRELIMINARY**



**Headquarters**

No. 4, Creation Rd. III  
Science-Based Industrial Park  
Hsinchu, Taiwan  
TEL: 886-35-770066  
FAX: 886-35-789467  
www: <http://www.winbond.com.tw/>

**Taipei Office**

11F, No. 115, Sec. 3, Min-Sheng East Rd.  
Taipei, Taiwan  
TEL: 886-2-7190505  
FAX: 886-2-7197502  
TLX: 16485 WINTPE

**Winbond Electronics (H.K.) Ltd.**

Rm. 803, World Trade Square, Tower II  
123 Hoi Bun Rd., Kwun Tong  
Kowloon, Hong Kong  
TEL: 852-27516023-7  
FAX: 852-27552064

**Winbond Electronics**

**(North America) Corp.**  
2730 Orchard Parkway  
San Jose, CA 95134 U.S.A.  
TEL: 1-408-9436666  
FAX: 1-408-9436668

**Please note that all data and specifications are subject to change without notice. All the trademarks of products and companies mentioned in this data sheet belong to their respective owners.**