



TK2051

STEREO 50W (8Ω) CLASS-T™ DIGITAL AUDIO AMPLIFIER DRIVER USING DIGITAL POWER PROCESSING (DPP™) TECHNOLOGY

Technical Information

Revision 1.1 – August 2002

GENERAL DESCRIPTION

The TK2051 (TC2000/TP2051 chipset) is a 50W continuous average power per channel, Class-T Digital Audio Power Amplifier using Tripath's proprietary Digital Power Processing™ technology. Class-T amplifiers offer both the audio fidelity of Class-AB and the power efficiency of Class-D amplifiers.

APPLICATIONS

- 5.1-Channel DVD
- Mini/Micro Component Systems
- Home Theater
- Stereo applications (6Ω / 8Ω)
- Mono applications (4Ω)

BENEFITS

- Single Supply Operation
- Very High Efficiency
- Wide Dynamic Range
- Compact layout

FEATURES

- Class-T Architecture
- High Output power
 - 35W @ 6Ω, < 1% THD+N
 - 50W @ 8Ω, < 3% THD+N
 - 117W @ 4Ω, < 10.0% THD+N (paralleled outputs)
- Audiophile Quality Sound
 - 0.007% THD+N @ 30W 8Ω
 - 0.005% THD+N @ 70W 4Ω (paralleled outputs)
- High Efficiency
 - 92% @ 60W 8Ω
 - 85% @ 46W 6Ω
 - 89% @ 117W 4Ω (paralleled outputs)
- Dynamic Range >100 dB

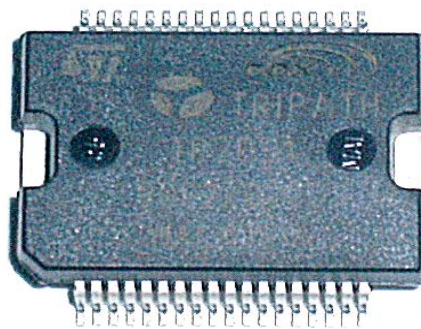
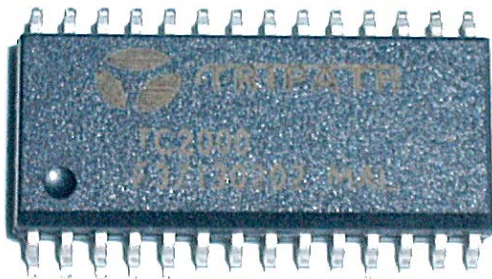

ABSOLUTE MAXIMUM RATINGS – TC2000 (Note 1)

SYMBOL	PARAMETER	Value	UNITS
V ₅	5V Power Supply	6	V
V _{logic}	Input Logic Level	V ₅ +0.3V	V
TA	Operating Free-air Temperature Range	-40 to 85	°C
T _{STORE}	Storage Temperature Range	-55 to 150	°C
T _{JMAX}	Maximum Junction Temperature	150	°C
ESD _{HB}	ESD Susceptibility – Human Body Model (Note 2), all pins	2000	V

Note 1: Absolute Maximum Ratings indicate limits beyond which damage to the device may occur.

See the table below for Operating Conditions.

Note 2: Human body model, 100pF discharged through a 1.5KΩ resistor.

ABSOLUTE MAXIMUM RATINGS – TP2051 (Note 1)

SYMBOL	PARAMETER	Value	UNITS
V _{CC}	Power Supply	40	V
V _{logic}	Input Logic Level	5.5	V
TA	Operating Free-air Temperature Range	0 to 70	°C
T _{STORE}	Storage Temperature Range	-40 to 150	°C
T _{JMAX}	Maximum Junction Temperature	150	°C
ESD _{HB}	ESD Susceptibility – Human Body Model (Note 2), all pins	2000	V

OPERATING CONDITIONS – TC2000 (Note 1)

SYMBOL	PARAMETER	MIN.	TYP.	MAX.	UNITS
V ₅	Supply Voltage	4.5	5	5.5	V
V _{HI}	Logic Input High	V ₅ -1.0			V
V _{LO}	Logic Input Low			1	V
T _A	Operating Temperature Range	-40	25	85	°C

OPERATING CONDITIONS – TP2051 (Note 1)

SYMBOL	PARAMETER	MIN.	TYP.	MAX.	UNITS
V _{CC}	Power Supply	10		36	V
V _{HI}	Logic Input High	I _{bias} /10 + 500mV			V
V _{LO}	Logic Input Low			I _{bias} /5 + 1V	V
T _A	Operating Temperature Range	0	25	70	°C

THERMAL CHARACTERISTICS**TC2000**

SYMBOL	PARAMETER	Value	UNITS
θ _{JA}	Junction-to-ambient Thermal Resistance (still air)	80	°C/W

TP2051

SYMBOL	PARAMETER	Value	UNITS
θ _{JC}	Junction-to-case Thermal Resistance	2.5	°C/W

ELECTRICAL CHARACTERISTICS – TC2000

SYMBOL	PARAMETER	MIN.	TYP.	MAX.	UNITS
I _S	Supply Current		60		mA
f _{sw}	Switching Frequency		650		kHz
V _{IN}	Input Sensitivity	0		1.5	V
V _{OUTH}	High Output Voltage	V5-0.5			V
V _{OUTLO}	Low Output Voltage			100	mV
R _{IN}	Input Impedance		2		k Ω
	Input DC Bias		2.5		V

ELECTRICAL CHARACTERISTICS – TP2051

T_A = 25 °C. See Application/Test Circuit. Unless otherwise noted, the supply voltage is V_{CC} = 28V.

SYMBOL	PARAMETER	CONDITIONS	MIN.	TYP.	MAX.	UNITS
I _q	Quiescent Current (No load, Mute = 0V)	V _{CC} = +28V		125		mA
		V ₅ = 5V		27	60	mA
I _{MUTE}	Mute Supply Current (No load, Mute = 5V)	V _{CC} = +31V		28		mA
		V ₅ = 5V		7		mA
V _{IH}	High-level input voltage (MUTE)	I _{IH} = See Mute Control Section	3.5			V
V _{IL}	Low-level input voltage (MUTE)	I _{IL} = See Mute Control Section			1.0	V
I _{SC}	Short circuit current limit	V _{CC} = +30V, T=25°C	3.5	5	6.5	A

PERFORMANCE CHARACTERISTICS – TK2051

T_A = 25 °C. Unless otherwise noted, V_{CC} = 30V, f=1kHz, and the measurement bandwidth is 20kHz.

SYMBOL	PARAMETER	CONDITIONS	MIN.	TYP.	MAX.	UNITS
P _{OUT}	Output Power (Continuous Average/Channel) (Note 13)	V _{CC} = +30V, R _L = 8 Ω		30		W
		THD+N < 0.01%		50		W
		THD+N < 3.0%		60		W
		THD+N < 10.0%				W
		V _{CC} = +23.5V, R _L = 6 Ω		30		W
		THD+N < 0.05%		40		W
		THD+N < 5.0%		45		W
		V _{CC} = +30V, R _L = 4 Ω (par. output)		75		W
		THD+N < 0.01%		117		W
THD + N	Total Harmonic Distortion Plus Noise	P _{OUT} = 40W/Channel, R _L = 8 Ω		0.03		%
		V _{CC} = +30V				%
		P _{OUT} = 30W/Channel, R _L = 6 Ω		0.03		%
IHF-IM	IHF Intermodulation Distortion	19kHz, 20kHz, 1:1 (IHF), R _L = 8 Ω		0.05		%
		P _{OUT} = 30W/Channel				%
SNR	Signal-to-Noise Ratio	A-Weighted 0dB = 50W/Channel, R _L = 8 Ω		103		dB
CS	Channel Separation	0dB = 10W, R _L = 8 Ω , f=1kHz		95		dB
A _V	Amplifier Gain	P _{OUT} = 10W/Channel, R _L = 8 Ω , See Application / Test Circuit		15		V/V
A _{ERROR}	Channel to Channel Gain Error	P _{OUT} = 10W/Channel, R _L = 8 Ω See Application / Test Circuit			0.5	dB
η	Power Efficiency	P _{OUT} = 60W/Channel, R _L = 8 Ω		92		%
		P _{OUT} = 45W/Channel, R _L = 6 Ω		85		%
e _N	Output Noise Voltage	A-Weighted, input AC grounded		135		μ V

TC2000 AUDIO SIGNAL PROCESSOR PIN DESCRIPTIONS

Pin	Function	Description
1	BIASCAP	Bandgap reference times two (typically 2.5VDC). Used to set the common mode voltage for the input op amps. This pin is not capable of driving external circuitry.
2, 6	FDBKP2, FDBKP1	Positive switching feedback.
3	DCMP	Internal mode selection. This pin must be grounded for proper device operation.
4, 7	FDBKN2, FDBKN1	Negative switching feedback.
5	VPWR	Test pin. Must be left floating.
8	HMUTE	Logic output. A logic high indicates both amplifiers are muted, due to the mute pin state, or a "fault".
9, 12	Y1, Y2	Non-inverted switching modulator outputs.
10, 11	Y1B, Y2B	Inverted switching modulator outputs.
13	NC	No connect
14	OCD2	Over Current Detect.
15	REF	Internal reference voltage; approximately 1.2 VDC.
16	OCD1	Over Current Detect. This pin must be grounded for proper device operation.
17	VnnSense	Negative power stage over/under supply voltage sense resistor tie point.
18	OVRLDB	A logic low output indicates the input signal has overloaded the amplifier.
19	VppSense	Positive power stage over/under supply voltage sense resistor tie point.
20	AGND	Ground
21	V5	5 Volt power supply input.
22, 27	Oaout1, Oaout2	Input stage output pins.
23, 28	Inv1, Inv2	Single-ended inputs. Inputs are a "virtual" ground of an inverting opamp with approximately 2.4VDC bias.
24	MUTE	When set to logic high, both amplifiers are muted and in idle mode. When low (grounded), both amplifiers are fully operational. If left floating, the device stays in the mute mode. Ground if not used.
25, 26	BBM0, BBM1	Break-before-make timing control to prevent shoot-through in the output FETs.

TC2000 AUDIO SIGNAL PROCESSOR PINOUT

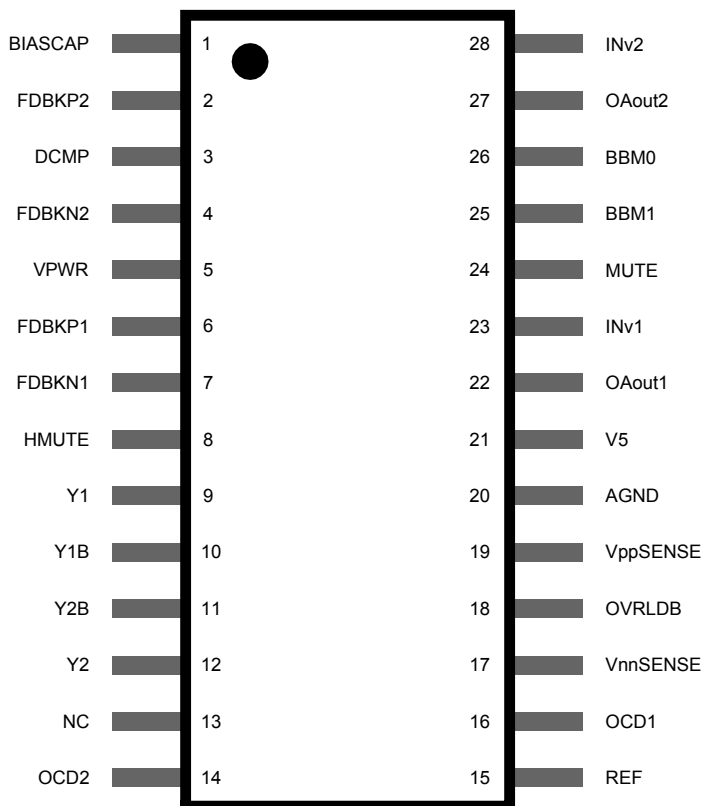

TP2051 POWER STAGE PIN DESCRIPTIONS

Pin	Function	Description
1	GND-SUB	Substrate ground
35,36	VccSign	Signal positive supply
15	Vcc1A	Positive supply
12	Vcc1B	Positive supply
7	Vcc2A	Positive supply
4	Vcc2B	Positive supply
14	GND1A	Negative supply
13	GND1B	Negative supply
6	GND2A	Negative supply
5	GND2B	Negative supply
16,17	OUT1A	Output half bridge 1A
10,11	OUT1B	Output half bridge 1B
8,9	OUT2A	Output half bridge 2A
2,3	OUT2B	Output half bridge 2B
29	IN1A	Input of half bridge 1A
30	IN1B	Input of half bridge 1B
31	IN2A	Input of half bridge 2A
32	IN2B	Input of half bridge 2B
21,22	Vdd	5V regulator referenced to ground
33,34	Vss	5V regulator referenced to Vcc
25	PWRDN	Stand-by pin
26	TRI-STATE	Hi-Z pin
27	FAULT	Fault output
24	CONFIG	Config input
28	TH-WAR	Thermal warning output
19	GND-clean	Logic ground
23	IBIAS	Logic high voltage
18	NC	Not connected
20	GND-Reg	Ground for Vdd regulator

TP2051 POWER STAGE PINOUT

(Top view with heat slug down)

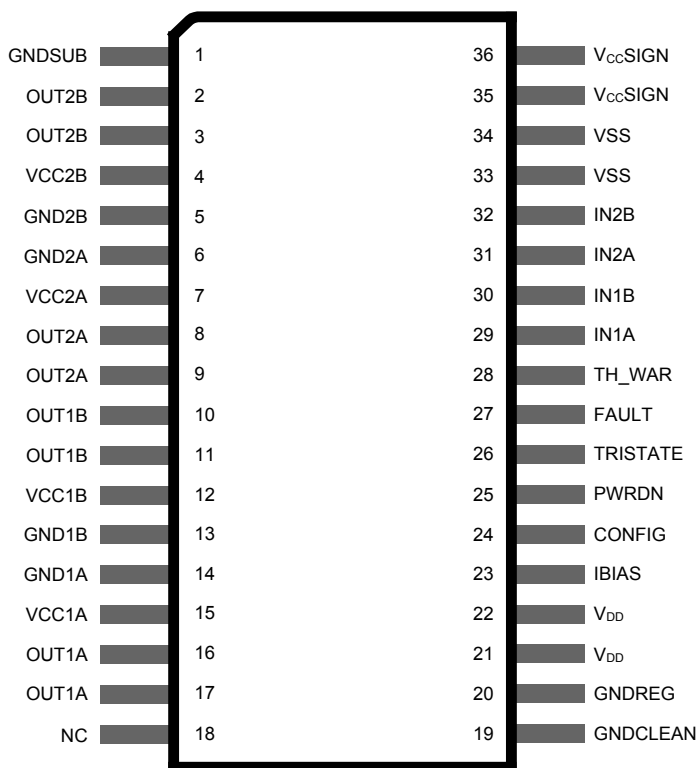

APPLICATION / TEST DIAGRAMS

Inputs and TC2000

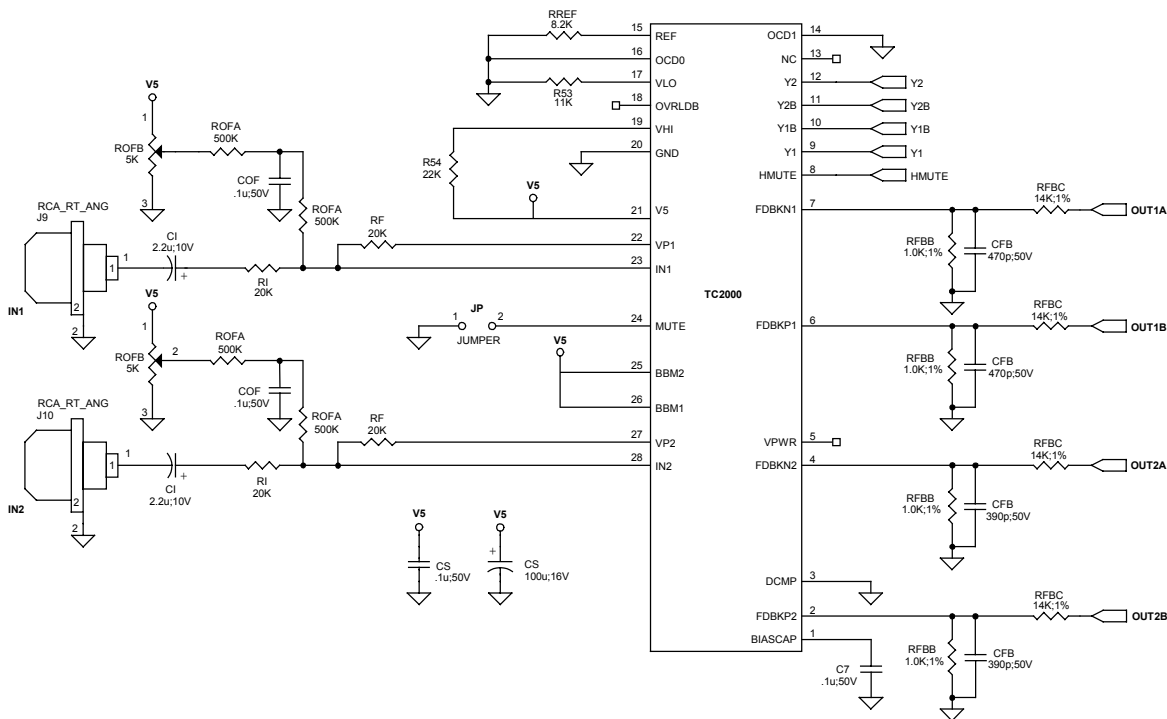

TP2051 and Outputs

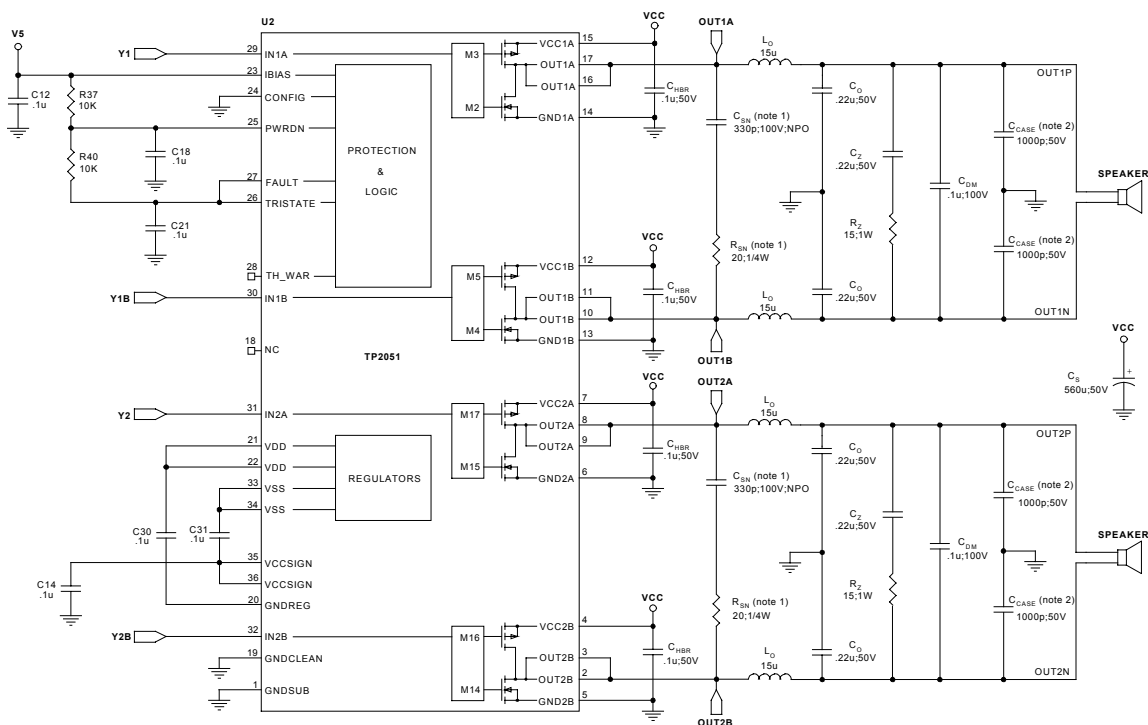

NOTE 1: C_{SN}/R_{SN} are optional locations, loaded only if required to reduce overshoot

NOTE 2: C_{CASE} (4 locations) represent bypass capacitors mounted at the exit of the speaker cable from the cabinet. They are optional and are used for EMI suppression. Lead lengths on these components must be kept short to be effective. They are shown in this schematic for reference.

APPLICATION / TEST DIAGRAMS FOR PARALLEL OPERATION

Inputs and TC2000

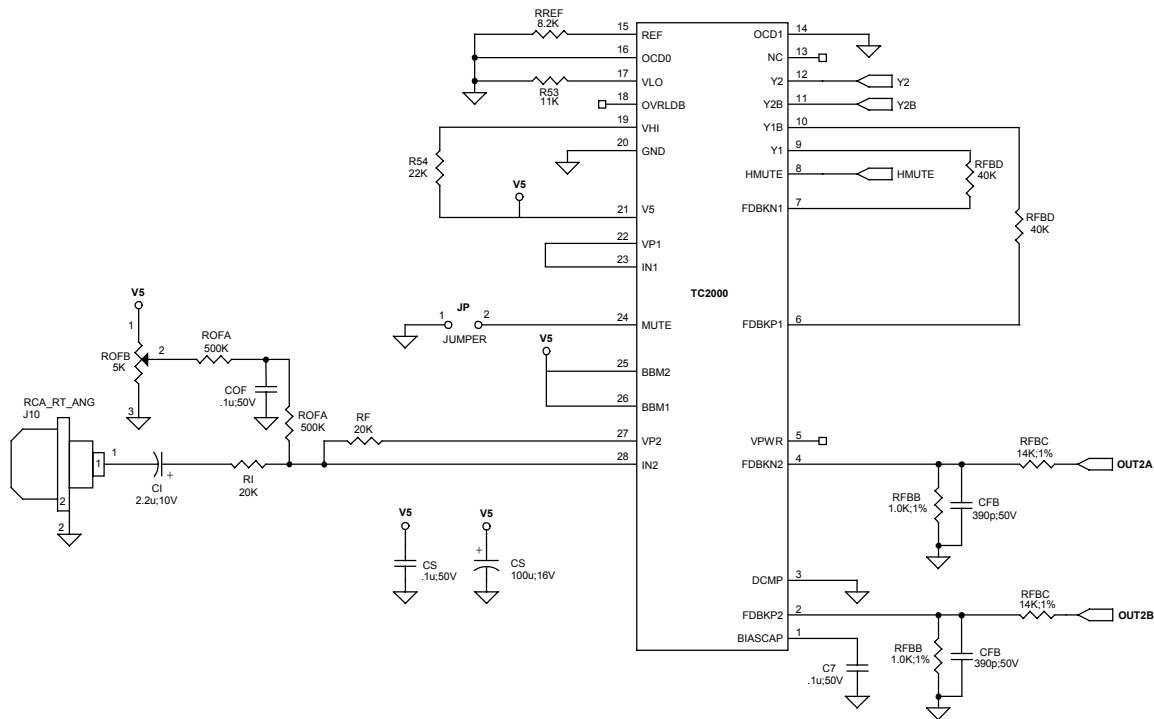

TP2051 and Outputs

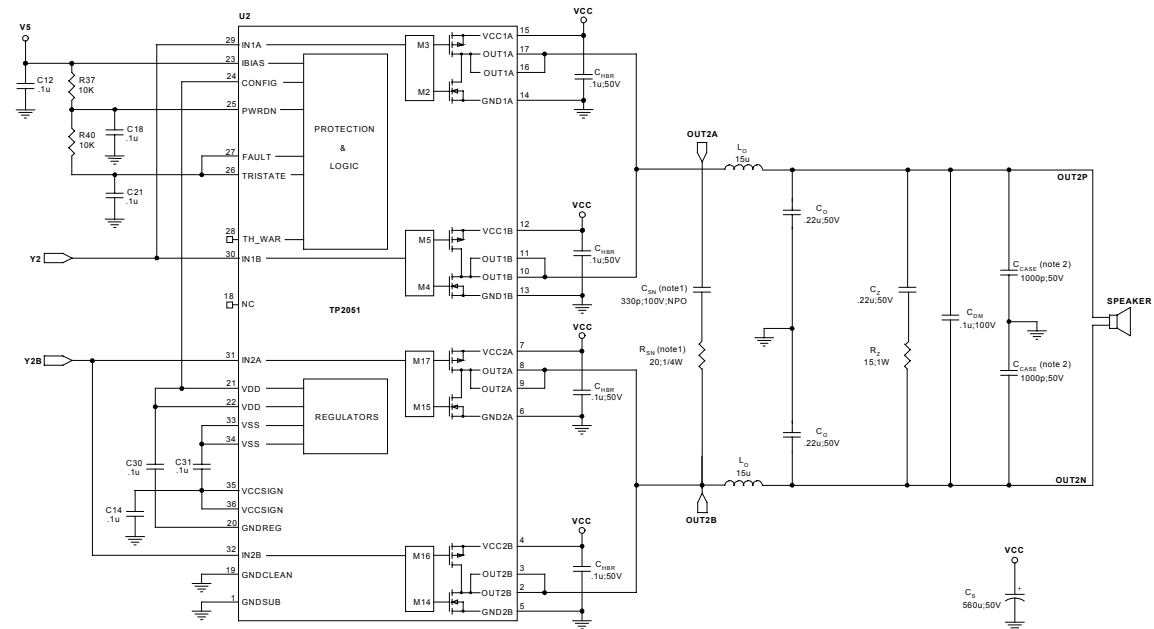

NOTE 1: C_{SN}/R_{SN} are optional locations, loaded only if required to reduce overshoot

NOTE 2: C_{CASE} (4 locations) represent bypass capacitors mounted at the exit of the speaker cable from the cabinet. They are optional and are used for EMI suppression. Lead lengths on these components must be kept short to be effective. They are shown in this schematic for reference.

EXTERNAL COMPONENTS DESCRIPTION (Refer to the Application/Test Circuit)

Components	Description
R _I	Inverting input resistance to provide AC gain in conjunction with R _F . This input is biased at the BIASCAP voltage (approximately 2.5VDC).
R _F	Feedback resistor to set AC gain in conjunction with R _I . Please refer to the Amplifier Gain paragraph, in the Application Information section.
C _I	AC input coupling capacitor, which, in conjunction with R _I , forms a high pass filter at $f_c = 1/(2\pi R_I C_I)$.
R _{FBB}	Feedback divider resistor connected to AGND. The value of this resistor depends on the supply voltage setting and helps set the TK2051 gain in conjunction with R _I , R _F , R _{FBA} , and R _{FBC} . Please see the Modulator Feedback Design paragraphs in the Application Information Section.
R _{FBC}	Feedback resistor connected from either the OUT1A/OUT2A to FDBKP1/FDBKP2 or OUT1B/OUT2B to FDBKN1/FDBKN2. The value of this resistor depends on the supply voltage setting and helps set the TK2051 gain in conjunction with R _I , R _F , R _{FBA} , and R _{FBB} . It should be noted that the resistor from OUT1/OUT2 to FBKOUT1/FBKOUT2 must have a power rating of greater than $P_{DISS} = VPP^2/(2R_{FBC})$. Please see the Modulator Feedback Design paragraphs in the Application Information Section.
C _{FB}	Feedback delay capacitor that both lowers the idle switching frequency and filters very high frequency noise from the feedback signal, which improves amplifier performance. The value of C _{FB} should be offset between channel 1 and channel 2 so that the idle switching difference is greater than 40kHz. Please refer to the Application / Test Circuit.
R _{OFB}	Potentiometer used to manually trim the DC offset on the output of the TK2051.
R _{OFA}	Resistor that limits the manual DC offset trim range and allows for more precise adjustment.
R _{REF}	Bias resistor. Locate close to pin 15 and ground at pin 20.
C _S	Supply decoupling for the power supply pins. For optimum performance, these components should be located close to the TC2000/TP2051 and returned to their respective ground as shown in the Application/Test Circuit.
C _Z	Zobel capacitor, which in conjunction with R _Z , terminates the output filter at high frequencies. Use a high quality film capacitor capable of sustaining the ripple current caused by the switching outputs.
R _Z	Zobel resistor, which in conjunction with C _Z , terminates the output filter at high frequencies. The combination of R _Z and C _Z minimizes peaking of the output filter under both no load conditions or with real world loads, including loudspeakers which usually exhibit a rising impedance with increasing frequency. The recommended power rating is 1 Watt.
L _O	Output inductor, which in conjunction with C _O , demodulates (filters) the switching waveform into an audio signal. Forms a second order filter with a cutoff frequency of $f_c = 1/(2\pi\sqrt{L_O C_O})$ and a quality factor of $Q = R_L C_O / \sqrt{L_O C_O}$.
C _O	Output capacitor, which, in conjunction with L _O , demodulates (filters) the switching waveform into an audio signal. Forms a second order low-pass filter with a cutoff frequency of $f_c = 1/(2\pi\sqrt{L_O C_O})$ and a quality factor of $Q = R_L C_O / \sqrt{L_O C_O}$. Use a high quality film capacitor capable of sustaining the ripple current caused by the switching outputs. Electrolytic capacitors should not be used.
C _{HBR}	High-frequency bypass capacitor for V _{CC} – GND on each supply pin. A 50V rating is required for this component.
C _{SN}	Optional snubber capacitor, which in conjunction with R _{SN} , reduces overshoot on non-optimal layouts. Only required if switching output overshoot is above rated voltage of TP2501. Use low-dissipation type (NPO).
R _{SN}	Optional snubber resistor, which in conjunction with C _{SN} , reduces overshoot on non-optimal layouts. Only required if switching output overshoot is above rated voltage of TP2501. Required ¼ Watt rating.
C _{DM}	Differential mode capacitor.

TYPICAL PERFORMANCE CHARACTERISTICS

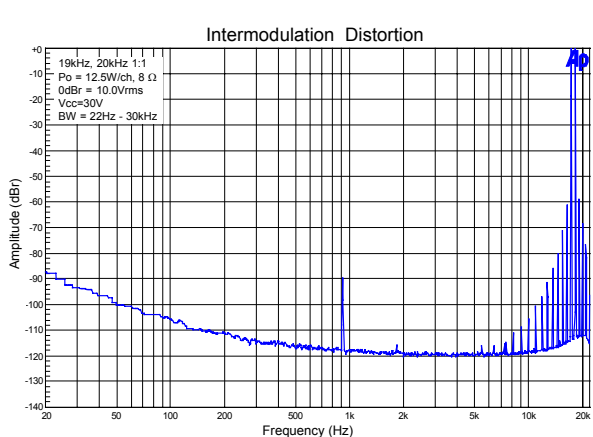
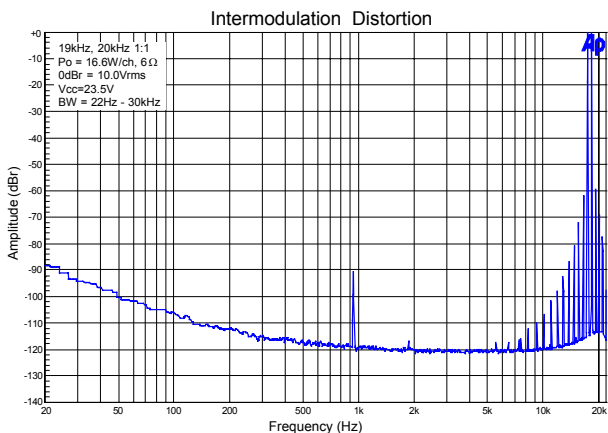
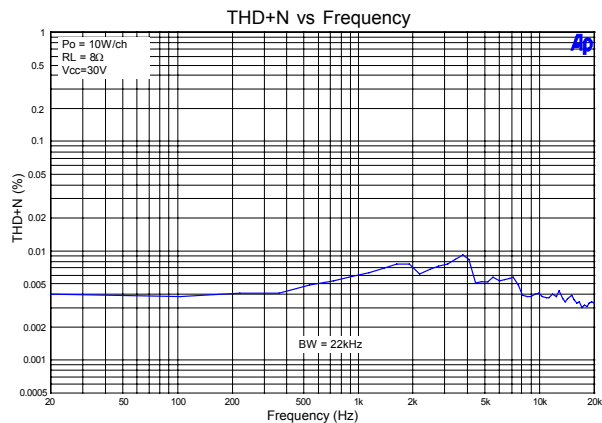
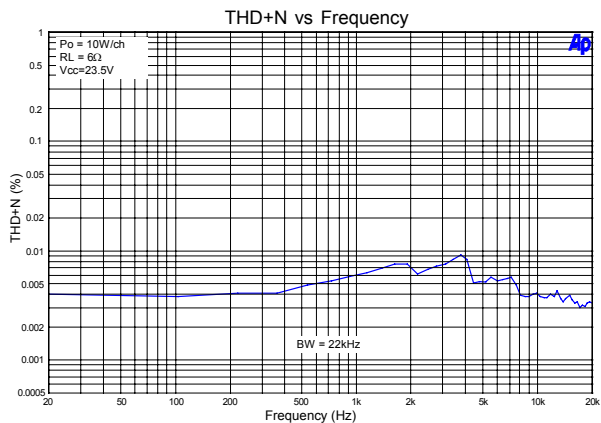
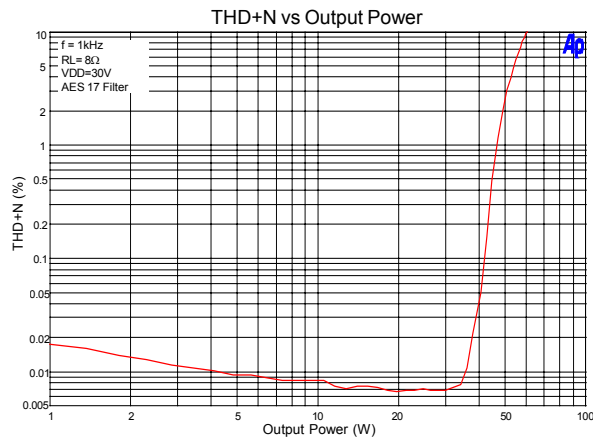
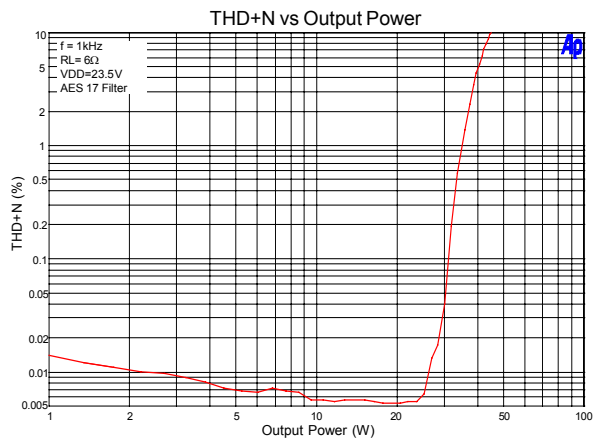

TYPICAL PERFORMANCE CHARACTERISTICS (cont'd)

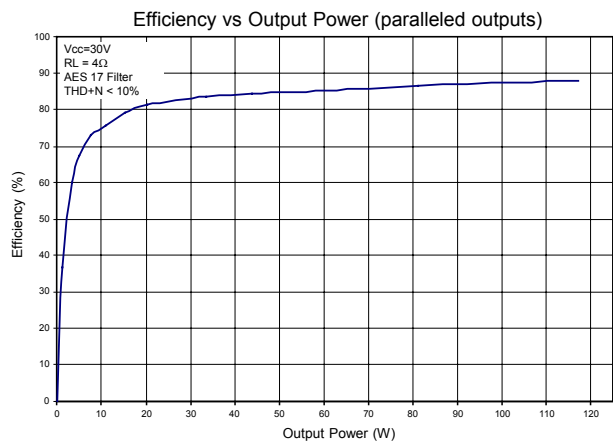
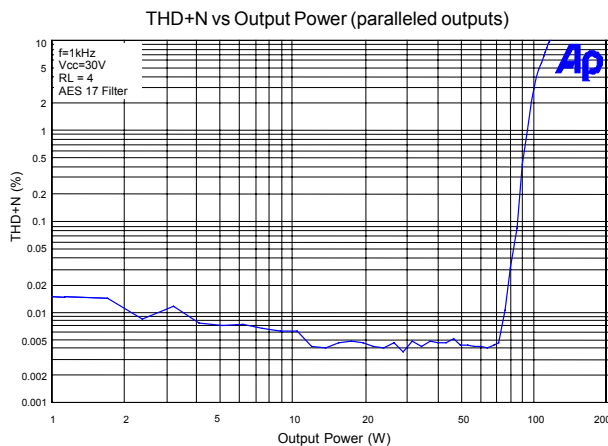
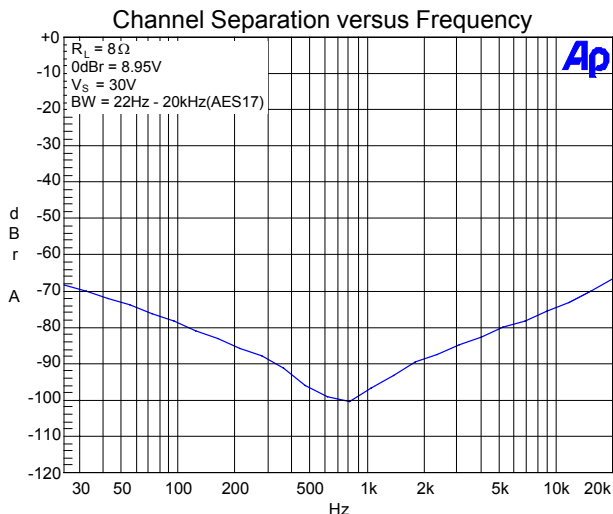
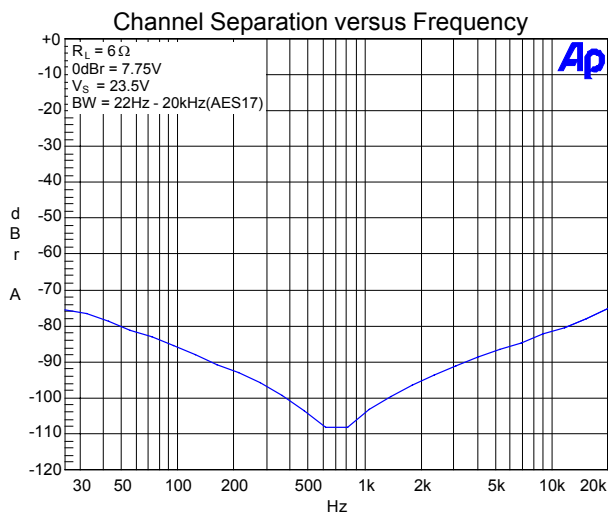
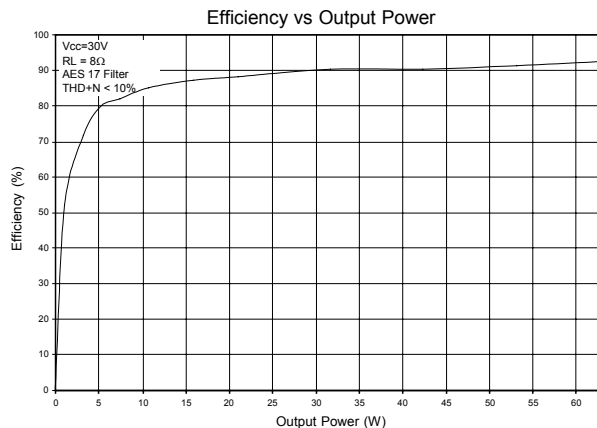
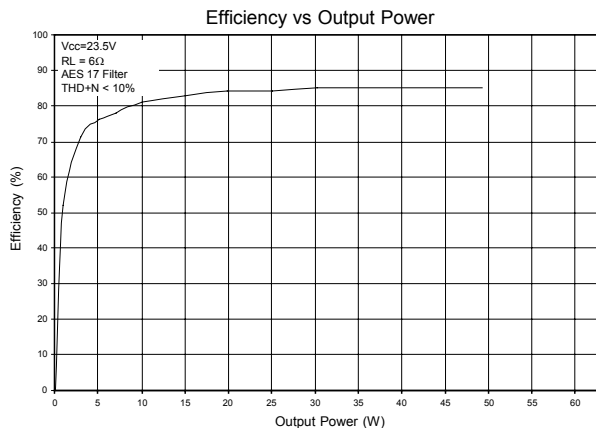

APPLICATION INFORMATION

TK2051 Basic Amplifier Operation

The TC2000 is a 5V CMOS signal processor that amplifies the audio input signal and converts the audio signal to a switching pattern. This switching pattern is spread spectrum with a typical idle switching frequency of about 700kHz. The switching patterns for the two channels are not synchronized and the idle switching frequencies should differ by at least 40kHz to avoid increasing the audio band noise floor. The idle frequency difference can be accomplished by offsetting the value of C_{FB} for each channel. Typical values of C_{FB} are 470pF for channel 1 and 390pF for channel 2.

The TP2051 is a MOSFET output stage that level-shifts the signal processor's 5V switching patterns to the power supply voltages and drives the power MOSFETs. The power MOSFETs are N-channel devices configured in full-bridges and are used to supply power to the output load. The outputs of the power MOSFETs must be low pass filtered to remove the high frequency switching pattern. A residual voltage from the switching pattern will remain on the speaker outputs when the recommended output LC filter is used, but this signal is outside of the audio band and will not affect audio performance.

Circuit Board Layout

The TK2051 is a power (high current) amplifier that operates at relatively high switching frequencies. The output of the amplifier switches between VPP and VNN at high speeds while driving large currents. This high-frequency digital signal is passed through an LC low-pass filter to recover the amplified audio signal. Since the amplifier must drive the inductive LC output filter and speaker loads, the amplifier outputs can be pulled above the supply voltage and below ground by the energy in the output inductance. To avoid subjecting the TK2051 to potentially damaging voltage stress, it is critical to have a good printed circuit board layout. It is recommended that Tripath's layout and application circuit be used for all applications and only be deviated from after careful analysis of the effects of any changes.

The following components are important to place near their associated TC2000/TP2051 pins and are ranked in order of layout importance, either for proper device operation or performance considerations.

- The capacitors C_{HBR} provide high frequency bypassing of the amplifier power supplies and will serve to reduce spikes across the supply rails. C_{HBR} should be kept within 1/8" (3mm) of the VCC pins. Please note that the four VCC pins must be decoupled separately. In addition, the voltage rating for C_{HBR} should be 50V as this capacitor is exposed to the full supply range. Similarly, capacitor C_S (one place) should be located as close as possible to the VCC pins on TP2051.
- C_{FB} removes very high frequency components from the amplifier feedback signals and lowers the output switching frequency by delaying the feedback signals. In addition, the value of C_{FB} is different for channel 1 and channel 2 to keep the average switching frequency difference greater than 40kHz. This minimizes in-band audio noise.
- To minimize noise pickup and minimize THD+N, R_{FBC} should be located as close to the TC2000 as possible. Make sure that the routing of the high voltage feedback lines is kept far away from the input op amps or significant noise coupling may occur. It is best to shield the high voltage feedback lines by using a ground plane around these traces as well as the input section.

In general, to enable placement as close to the TC2000/TP2051, and minimize PCB parasitics, the capacitors listed above should be surface mount types.

Some components are not sensitive to location but are very sensitive to layout and trace routing.

- To maximize the damping factor and reduce distortion and noise, the modulator feedback connections should be routed directly to the pins of the output inductors, L_O .
- The modulator feedback resistors, R_{FBA} and R_{FBB} should all be grounded and attached to 5V together. These connections will serve to minimize common mode noise via the differential feedback.

TK2051 Grounding

Proper grounding techniques are required to maximize TK2051 functionality and performance. Parametric parameters such as THD+N, noise floor and cross talk can be adversely affected if proper grounding techniques are not implemented on the PCB layout. The following discussion highlights some recommendations about grounding both with respect to the TK2051 as well as general “audio system” design rules.

The TK2051 is divided into two sections: the input section, and the output (high power) section. On the TK2051 evaluation board, the ground is also divided into distinct sections, one for the input and one for the output. To minimize ground loops and keep the audio noise floor as low as possible, the input and output ground must be only connected at a single point. Depending on the system design, the single point connection may be in the form of a ferrite bead or a PCB trace.

Modulator Feedback Design

The modulator converts the signal from the input stage to the high-voltage output signal. The optimum gain of the modulator is determined from the maximum allowable feedback level for the modulator and maximum supply voltage for the power stage. Depending on the maximum supply voltage, the feedback ratio will need to be adjusted to maximize performance. The values of R_{FBB} and R_{FBC} (see explanation below) define the gain of the modulator. Once these values are chosen, based on the maximum supply voltage, the gain of the modulator will be fixed even with as the supply voltage fluctuates due to current draw.

For the best signal-to-noise ratio and lowest distortion, the maximum differential modulator feedback voltage should be approximately 4Vpp. This will keep the gain of the modulator as low as possible and still allow headroom so that the feedback signal does not clip the modulator feedback stage.

The modulator feedback resistors are:

$$R_{FBB} = \text{User specified; typically } 1\text{k}\Omega$$

$$R_{FBC} = \left(\frac{V_{CC} * R_{FBB}}{2V} \right) - R_{FBB}$$

TK2051 Amplifier Gain

The gain of the TK2051 is the product of the input stage gain and the modulator gain. Please refer to the sections, Input Stage Design, and Modulator Feedback Design, for a complete explanation of how to determine the external component values.

$$A_{VTK2051} = A_{VINPSTAGE} * A_{V\text{ MODULATOR}}$$

$$A_{VTK2051} \approx \frac{R_F}{R_I} \left(\frac{R_{FBC} + R_{FBB}}{R_{FBB}} \right)$$

For example, using a TK2051 with the following external components,

$$\begin{aligned} R_I &= 20k\Omega \\ R_F &= 20k\Omega \\ R_{FBB} &= 1k\Omega \\ R_{FBC} &= 14k\Omega \end{aligned}$$

$$A_{VTK2051} \approx \frac{20k\Omega}{20k\Omega} \left(\frac{14k\Omega + 1k\Omega}{1k\Omega} \right) = 15 \frac{V}{V}$$

Input Stage Design

The TC2000 input stage is configured as an inverting amplifier, allowing the system designer flexibility in setting the input stage gain and frequency response. Figure 1 shows a typical application where the input stage is a constant gain inverting amplifier. The input stage gain should be set so that the maximum input signal level will drive the input stage output to 4Vpp.

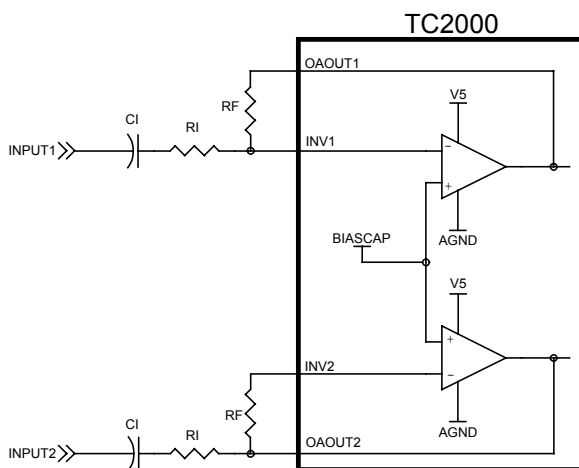

Figure 1: Input Stage

The gain of the input stage, above the low frequency high pass filter point, is that of a simple inverting amplifier: It should be noted that the input amplifiers are biased at approximately 2.5VDC. Thus, the polarity of C_I must be followed as shown in Figure 1 for a standard ground referenced input signal

$$A_{VINPSTAG} = - \frac{R_F}{R_I}$$

Input Capacitor Selection

C_I can be calculated once a value for R_I has been determined. C_I and R_I determine the input low frequency pole. Typically this pole is set below 10Hz. C_I is calculated according to:

$$C_I = \frac{1}{2\pi f_P R_I}$$

where:

R_I = Input resistor value in ohms.

f_P = Input low frequency pole (typically 10Hz or below)

Mute Control

When a logic high signal is supplied to MUTE, both amplifier channels are muted (both high- and low-side transistors are turned off). When a logic level low is supplied to MUTE, both amplifiers are fully operational. There is a delay of approximately 200 milliseconds between the de-assertion of MUTE and the un-muting of the TK2051.

To ensure proper device operation, including minimization of turn on/off transients that can result in undesirable audio artifacts, Tripath recommends that the TK2051 device be muted prior to power up or power down of the 5V supply. The “sensing” of the V5 supply can be easily accomplished by using a “microcontroller supervisor” or equivalent to drive the TC2000 mute pin high when the V5 voltage is below 4.5V. This will ensure proper operation of the TK2051 input circuitry. A micro-controller supervisor such as the MCP101-450 from Microchip Corporation has been used by Tripath to implement clean power up/down operation.

If turn-on and/or turn-off noise is still present with a TK2051 amplifier, the cause may be other circuitry external to the TK2051. While the TK2051 has circuitry to suppress turn-on and turn-off transients, the combination of power supply and other audio circuitry with the TK2051 in a particular application may exhibit audible transients. One solution that will completely eliminate turn-on and turn-off pops and clicks is to use a relay to connect/disconnect that amplifier from the speakers with the appropriate timing during power on/off.

TK2051 Output Capability

The TK2051 can drive two 8 Ohm loads with 45 Watts each at less than 0.05% THD+N. The maximum sustained amplifier output power will be determined by a number of factors including the TC2000/TP2051 junction temperatures, the load impedance and the power supply voltage.

Tripath does not recommend driving loads below 6 Ohms single ended as the amplifier efficiency will be reduced and the amplifier will reach it's current limit at relatively low power output levels. With the outputs connected in parallel, however, the TK2051 is capable of driving single channel loads down to 4 Ohms with very high power capability. In such applications, special consideration must be give to cooling of the TP2051 power device.

Paralleled Outputs

For stereo mode operation, the TK2051 is a dual full bridge. For parallel mode operation, the TK2051 can be configured as a single full bridge with double current capability by connecting the CONFIG pin to the Vdd pin of the TP2051. Please refer to the Applications/Test Diagram for Parallel Operation.

Output Voltage Offset

The TK2051 does not have internal compensation for DC offset. If offset is a consideration for the intended application, trimming of the input offset voltage will be required. Tripath has had success with both active and passive circuits for this purpose; please consult with the Tripath applications team for further information or review the EB-TK2051 datasheet for a full description of input trimming.

Output Filter Design

Tripath amplifiers generally have a higher switching frequency than PWM implementations, allowing the use of higher cutoff frequency filters and reducing the load dependent peaking/drooping in the 20kHz audio band. This is especially important for applications where the end customer may attach any speaker to the amplifier (as opposed to a system where speakers are shipped with the amplifier), since speakers are not purely resistive loads and the impedance they present changes over frequency and from speaker model to speaker model. An RC network, or “Zobel” (R_z , C_z) should be placed at the filter output to control the impedance “seen” by the TP2051 when not attached to a

speaker load. The TK2051 works well with a 2nd order, 80kHz LC filter with $L_O = 10\mu\text{H}$ and $C_O = 0.47\mu\text{F}$ and $R_Z = 10\ \Omega/1\text{W}$ and $C_Z = 0.47\mu\text{F}$.

NOTE: Output inductor selection is a critical design step. The core material and geometry of the output filter inductor affects the TK2051 distortion levels, efficiency, power dissipation and EMI output.

Minimum and Maximum Supply Voltage Operating Range

The TK2051 can operate over a wide range of power supply voltages from +12V to +30V. In order to optimize operation for either the low or high range, the user must select the proper values for R_{FBB} , and R_{FBC} .

Protection Circuits

The TK2051 is protected against over-current, over / under-voltage and over-temperature conditions.

Over-temperature Protection

An over-temperature fault occurs if the junction temperature of the part exceeds approximately 165°C. The thermal hysteresis of the part is approximately 30°C, therefore the fault will automatically clear when the junction temperature drops below 135°C.

HMUTE

The HMUTE pin is a 5V logic output that indicates various fault conditions within the device. It is not normally used in product applications.

OVRLDB

The OVRLDB pin is a 5V logic output that is asserted just at the onset of clipping. When low, it indicates that the level of the input signal has overloaded the amplifier resulting in increased distortion at the output. The OVRLDB signal can be used to control a distortion indicator light or LED through a simple buffer circuit, as the OVRLDB cannot drive an LED directly. There is a 20K resistor on chip in series with the OVRLDB output.

Performance Measurements of the TK2051

The TK2051 operates by generating a high frequency switching signal based on the audio input. This signal is sent through a low-pass filter (external to the Tripath amplifier) that recovers an amplified version of the audio input. The frequency of the switching pattern is spread spectrum in nature and typically varies between 100kHz and 1MHz, which is well above the 20Hz – 20kHz audio band. The pattern itself does not alter or distort the audio input signal, but it does introduce some inaudible components.

The measurements of certain performance parameters, particularly noise related specifications such as THD+N, are significantly affected by the design of the low-pass filter used on the output as well as the bandwidth setting of the measurement instrument used. Unless the filter has a very sharp roll-off just beyond the audio band or the bandwidth of the measurement instrument is limited, some of the inaudible noise components introduced by the TK2051 amplifier switching pattern will degrade the measurement.

One feature of the TK2051 is that it does not require large multi-pole filters to achieve excellent performance in listening tests, usually a more critical factor than performance measurements. Though using a multi-pole filter may remove high-frequency noise and improve THD+N type measurements (when they are made with wide-bandwidth measuring equipment), these same filters

degrade frequency response. The TK2051 Evaluation Board uses the Application/Test Circuit of this data sheet, which has a simple two-pole output filter and excellent performance in listening tests. Measurements in this data sheet were taken using this same circuit with a limited bandwidth setting in the measurement instrument.

PACKAGE INFORMATION - TC2000

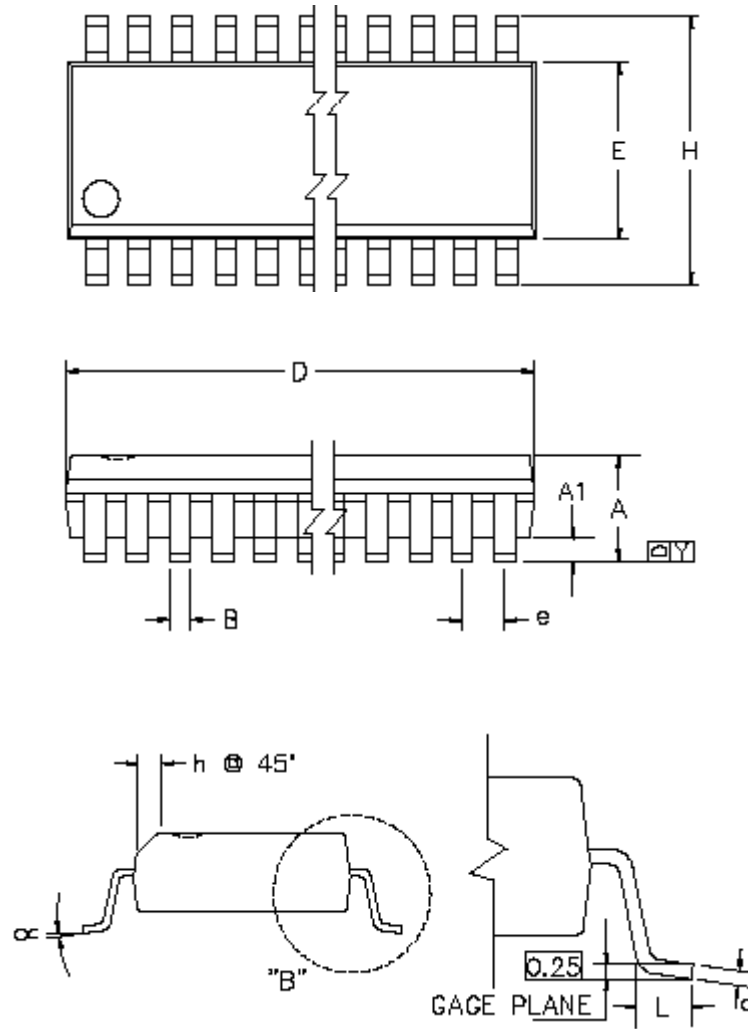

CONTROL DIMENSIONS ARE IN MM						
SYMBOL	MILLIMETER			INCH		
	MIN	NOM	MAX	MIN	NOM	MAX
A	2.35	2.54	2.65	0.092	0.100	0.104
A1	0.10	0.17	0.30	0.004	0.006	0.012
B	0.33	0.42	0.51	0.013	0.016	0.020
C	0.23	0.25	0.32	0.009	0.010	0.012
E	7.40	7.50	7.60	0.291	0.295	0.299
e		1.27			0.050	
H	10.00	10.30	10.65	0.394	0.406	0.419
h	0.25	0.50	0.75	0.009	0.020	0.029
L	0.40	0.70	1.27	0.015	0.028	0.050
α	0°		8°	0°		8°
Y	0		0.10	0		0.004
D	17.70	17.90	18.10	0.697	0.705	0.712

Package Information - TP2051

DIM.	mm			inch		
	MIN.	TYP.	MAX.	MIN.	TYP.	MAX.
A			3.60			0.141
a1	0.10		0.30	0.004		0.012
a2			3.30			0.130
a3	0		0.10	0		0.004
b	0.22		0.38	0.008		0.015
c	0.23		0.32	0.009		0.012
D (1)	15.80		16.00	0.622		0.630
D1	9.40		9.80	0.370		0.385
E	13.90		14.50	0.547		0.570
e		0.65			0.025	
e3		11.05			0.435	
E1 (1)	10.90		11.10	0.429		0.437
E2			2.90			0.114
E3	5.80		6.20	0.228		0.244
E4	2.90		3.20	0.114		0.126
G	0		0.10	0		0.004
H	15.50		15.90	0.610		0.626
h			1.10			0.043
L	0.80		1.10	0.031		0.043
N	10°(max.)					
S	8°(max.)					

(1): "D" and "E1" do not include mold flash or protrusions
 - Mold flash or protrusions shall not exceed 0.15mm (0.006 inch)
 - Critical dimensions are "a3", "E" and "G".

OUTLINE AND MECHANICAL DATA

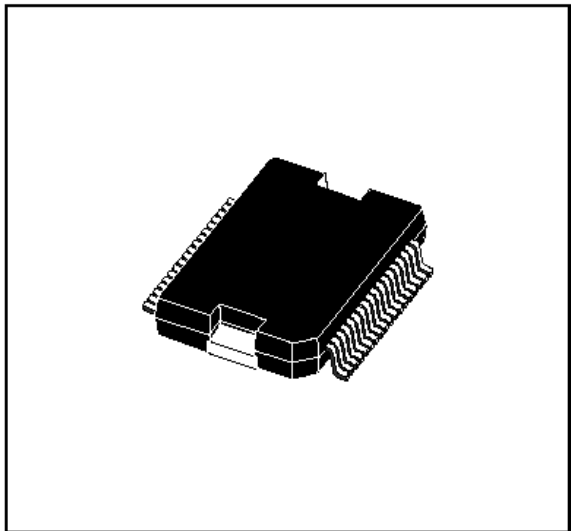

PowerSO36

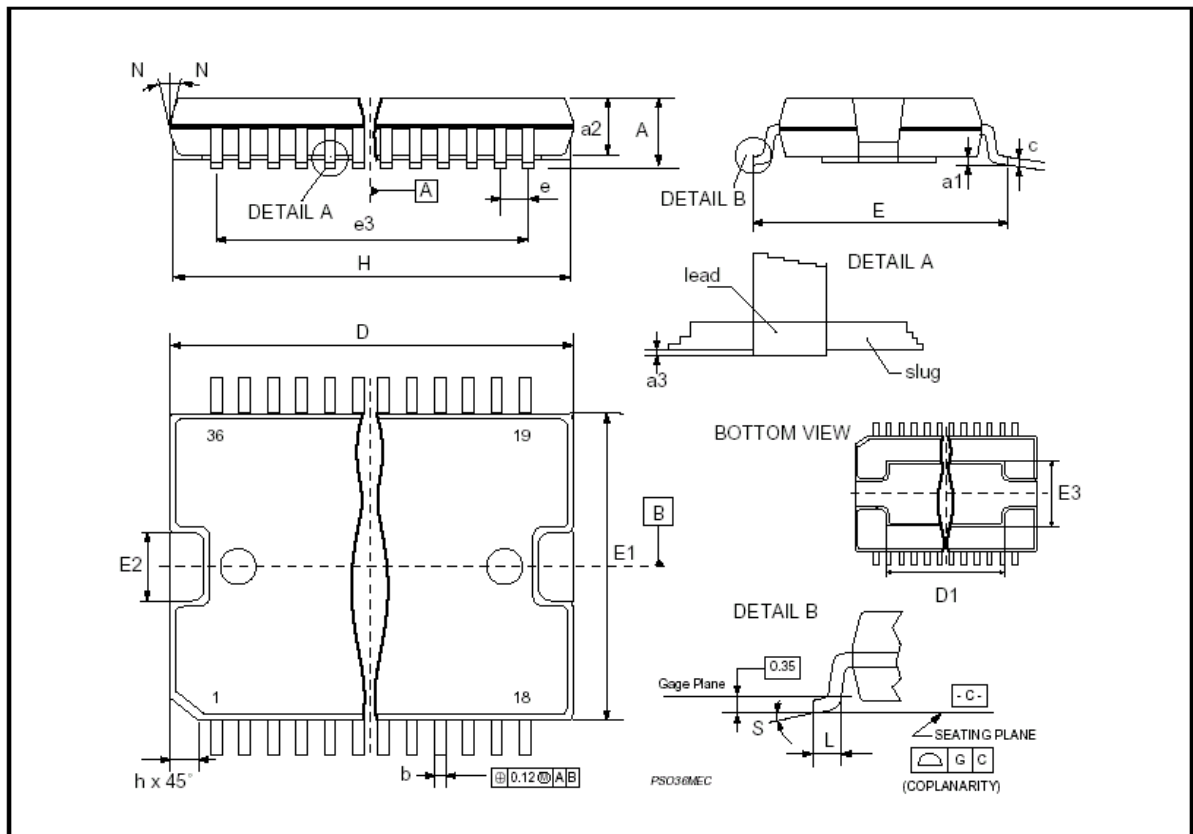

Tripath and Digital Power Processing are trademarks of Tripath Technology Inc. Other trademarks referenced in this document are owned by their respective companies.

Tripath Technology Inc. reserves the right to make changes without further notice to any products herein to improve reliability, function or design. Tripath does not assume any liability arising out of the application or use of any product or circuit described herein; neither does it convey any license under its patent rights, nor the rights of others.

TRIPATH'S PRODUCTS ARE NOT AUTHORIZED FOR USE AS CRITICAL COMPONENTS IN LIFE SUPPORT DEVICES OR SYSTEMS WITHOUT THE EXPRESS WRITTEN CONSENT OF THE PRESIDENT OF TRIPATH TECHNOLOGY INC. As used herein:

1. Life support devices or systems are devices or systems which, (a) are intended for surgical implant into the body, or (b) support or sustain life, and whose failure to perform, when properly used in accordance with instructions for use provided in this labeling, can be reasonably expected to result in significant injury to the user.
2. A critical component is any component of a life support device or system whose failure to perform can be reasonably expected to cause the failure of the life support device or system, or to affect its safety or effectiveness.

For more information on Tripath products, visit our web site at: <http://www.tripath.com>

Other useful documents concerning the TK2051 available on the Tripath website.

EB-TK2051 Evaluation Board – TK2051 Evaluation Board Document
RB-TK2051 Two Channel Reference board – RB-TK2051 Board Design Document
RB-TK2051 Six Channel Board – Six-channel reference design using the TK2051

Contact Information

TRIPATH TECHNOLOGY, INC

2560 Orchard Parkway, San Jose, CA 95131
408.750.3000 - P
408.750.3001 - F

For more Sales Information, please visit us @ www.tripath.com/cont_s.htm
For more Technical Information, please visit us @ www.tripath.com/data.htm

This datasheet has been download from:

www.datasheetcatalog.com

Datasheets for electronics components.