

SPANSION™ Flash Memory

Data Sheet



September 2003

This document specifies SPANSION™ memory products that are now offered by both Advanced Micro Devices and Fujitsu. Although the document is marked with the name of the company that originally developed the specification, these products will be offered to customers of both AMD and Fujitsu.

Continuity of Specifications

There is no change to this datasheet as a result of offering the device as a SPANSION™ product. Future routine revisions will occur when appropriate, and changes will be noted in a revision summary.

Continuity of Ordering Part Numbers

AMD and Fujitsu continue to support existing part numbers beginning with "Am" and "MBM". To order these products, please use only the Ordering Part Numbers listed in this document.

For More Information

Please contact your local AMD or Fujitsu sales office for additional information about SPANSION™ memory solutions.



FLASH MEMORY

CMOS

32 M (4 M × 8/2 M × 16) BIT

MBM29LV320TE 80/90/100

MBM29LV320BE 80/90/100

DESCRIPTION

The MBM29LV320TE/BE is 32 M-bit, 3.0 V-only Flash memory organized as 4 M bytes of 8 bits each or 2 M words of 16 bits each. The device is offered in a 48-pin TSOP (1) and 63-ball FBGA packages. This device is designed to be programmed in-system with the standard system 3.0 V V_{CC} supply. 12.0 V V_{PP} and 5.0 V V_{CC} are not required for write or erase operations. The device can also be reprogrammed in standard EPROM programmers.

The standard device offers access times 80 ns, 90 ns and 100 ns, allowing operation of high-speed microprocessors without wait state. To eliminate bus contention the device has separate chip enable (\overline{CE}), write enable (\overline{WE}) and output enable (\overline{OE}) controls.

(Continued)

PRODUCT LINE UP

Part No.	MBM29LV320TE/BE		
	80	90	100
Power Supply Voltage (V)	$V_{CC} = 3.3 V_{\pm 0.3 V}$		$V_{CC} = 3.0 V_{\pm 0.6 V}$
Max Address Access Time (ns)	80	90	100
Max \overline{CE} Access Time (ns)	80	90	100
Max \overline{OE} Access Time (ns)	30	35	35

PACKAGES

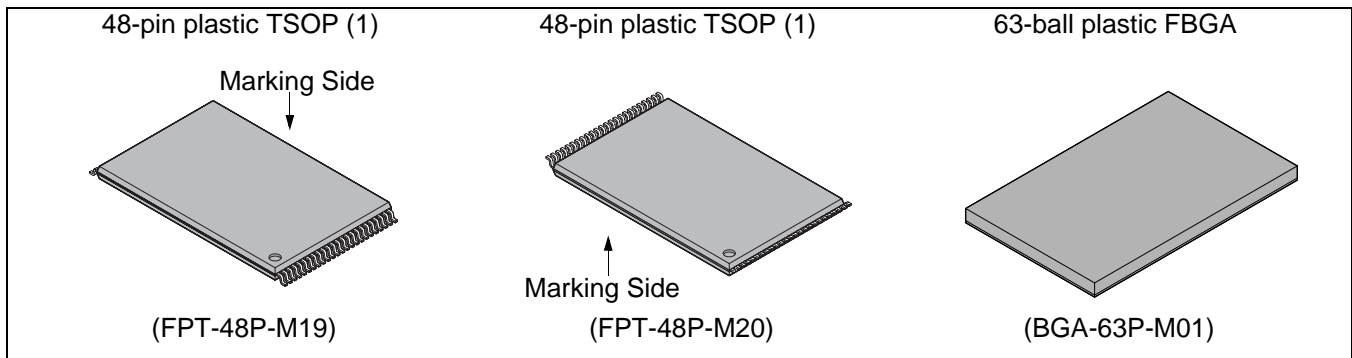

MBM29LV320TE/BE_{80/90/10}

(Continued)

The device is pin and command set compatible with JEDEC standard E²PROMs. Commands are written to the command register using standard microprocessor write timings. Register contents serve as input to an internal state-machine which controls the erase and programming circuitry. Write cycles also internally latch addresses and data needed for the programming and erase operations. Reading data out of the device is similar to reading from 5.0 V and 12.0 V Flash or EPROM devices.

The device is programmed by executing the program command sequence. This invokes the Embedded Program Algorithm which is an internal algorithm that automatically times the program pulse widths and verifies proper cell margin. Typically, each sector can be programmed and verified in about 0.5 seconds. Erase is accomplished by executing the erase command sequence. This invokes the Embedded Erase Algorithm which is an internal algorithm that automatically preprograms the array if it is not already programmed before executing the erase operation. During erase, the device automatically time the erase pulse widths and verify proper cell margin.

A sector is Typically erased and verified in 1.0 second. (If already completely preprogrammed.)

The device also features a sector erase architecture. The sector mode allows each sector to be erased and reprogrammed without affecting other sectors. The device is erased when shipped from the factory.

The device features single 3.0 V power supply operation for both read and write functions. Internally generated and regulated voltages are provided for the program and erase operations. A low V_{CC} detector automatically inhibits write operations on the loss of power. The end of program or erase is detected by Data Polling of DQ₇, by the Toggle Bit feature on DQ₆, or the RY/ $\overline{\text{BY}}$ output pin. Once the end of a program or erase cycle is completed, the device internally resets to the read mode.

The device also has a hardware $\overline{\text{RESET}}$ pin. When this pin is driven low, execution of any Embedded Program Algorithm or Embedded Erase Algorithm is terminated. The internal state machine is then reset to the read mode. The $\overline{\text{RESET}}$ pin may be tied to the system reset circuitry. Therefore, if a system reset occurs during the Embedded Program Algorithm or Embedded Erase Algorithm, the device is automatically reset to the read mode and will have erroneous data stored in the address locations being programmed or erased. These locations need re-writing after the reset. Resetting the device enables the system's microprocessor to read the boot-up firmware from the Flash memory.

Fujitsu Flash technology combines years of EPROM and E²PROM experience to produce the highest levels of quality, reliability, and cost effectiveness. The device memory electrically erase the entire chip or all bits within a sector simultaneously via Fowler-Nordheim tunneling. The bytes/words are programmed one byte/word at a time using the EPROM programming mechanism of hot electron injection.

■ FEATURES

- **0.23 μ m Process Technology**
- **Single 3.0 V Read, Program, and Erase**
Minimized system level power requirements
- **Compatible with JEDEC-standard Commands**
Use the same software commands as E²PROMs
- **Compatible with JEDEC-standard Worldwide Pinouts**
48-pin TSOP (1) (Package suffix : TN – Normal Bend Type, TR – Reversed Bend Type)
63-ball FBGA (Package suffix : PBT)
- **Minimum 100,000 Program/Erase Cycles**
- **High Performance**
80 ns maximum access time
- **Sector Erase Architecture**
Eight 4 K word and sixty-three 32 K word sectors in word mode
Eight 8 K byte and sixty-three 64 K byte sectors in byte mode
Any combination of sectors can be concurrently erased. Also supports full chip erase.
- **Boot Code Sector Architecture**
T = Top sector
B = Bottom sector
- **HiddenROM Region**
256 byte of HiddenROM, accessible through a new “HiddenROM Enable” command sequence
Factory serialized and protected to provide a secure electronic serial number (ESN)
- **WP/ACC Input Pin**
At V_{IL}, allows protection of boot sectors, regardless of sector protection/unprotection status
At V_{ACC}, increases program performance
- **Embedded Erase™* Algorithms**
Automatically pre-programs and erases the chip or any sector
- **Embedded Program™* Algorithms**
Automatically writes and verifies data at specified address
- **Data Polling and Toggle Bit feature for detection of program or erase cycle completion**
- **Ready/Busy output (RY/BY)**
Hardware method for detection of program or erase cycle completion
- **Automatic sleep mode**
When addresses remain stable, automatically switch themselves to low power mode.
- **Low V_{CC} write inhibit \leq 2.5 V**
- **Erase Suspend/Resume**
Suspends the erase operation to allow a read data and/or program in another sector within the same device
- **Sector group protection**
Hardware method disables any combination of sector groups from program or erase operations
- **Sector Group Protection Set function by Extended sector group protection command**
- **Fast Programming Function by Extended Command**
- **Temporary sector group unprotection**
Temporary sector group unprotection via the $\overline{\text{RESET}}$ pin.
- **In accordance with CFI (Common Flash Memory Interface)**

*: Embedded Erase™ and Embedded Program™ are trademarks of Advanced Micro Devices, Inc.

MBM29LV320TE/BE_{80/90/10}

■ PIN ASSIGNMENTS

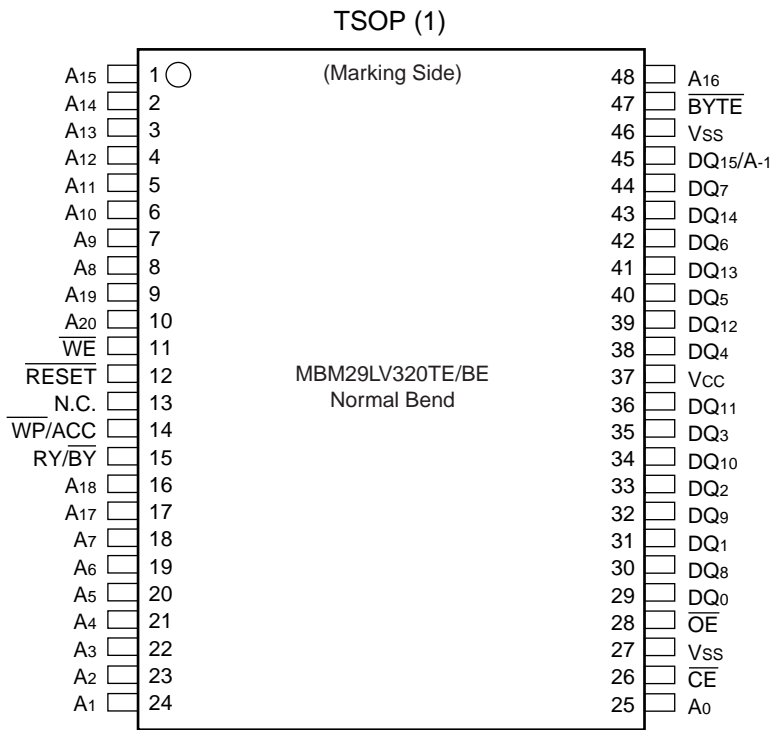

(FPT-48P-M19)

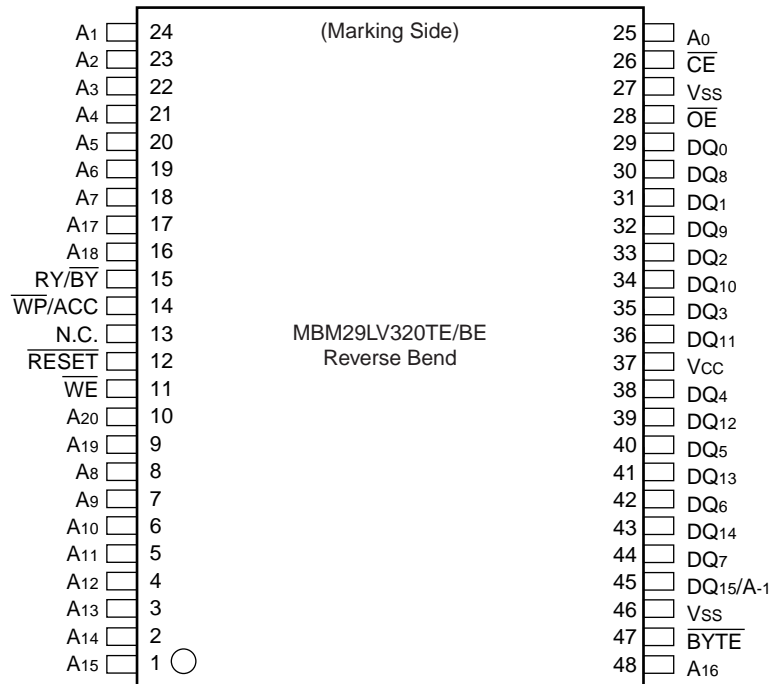

(FPT-48P-M20)

(Continued)

(Continued)

FBGA
(TOP VIEW)
Marking Side

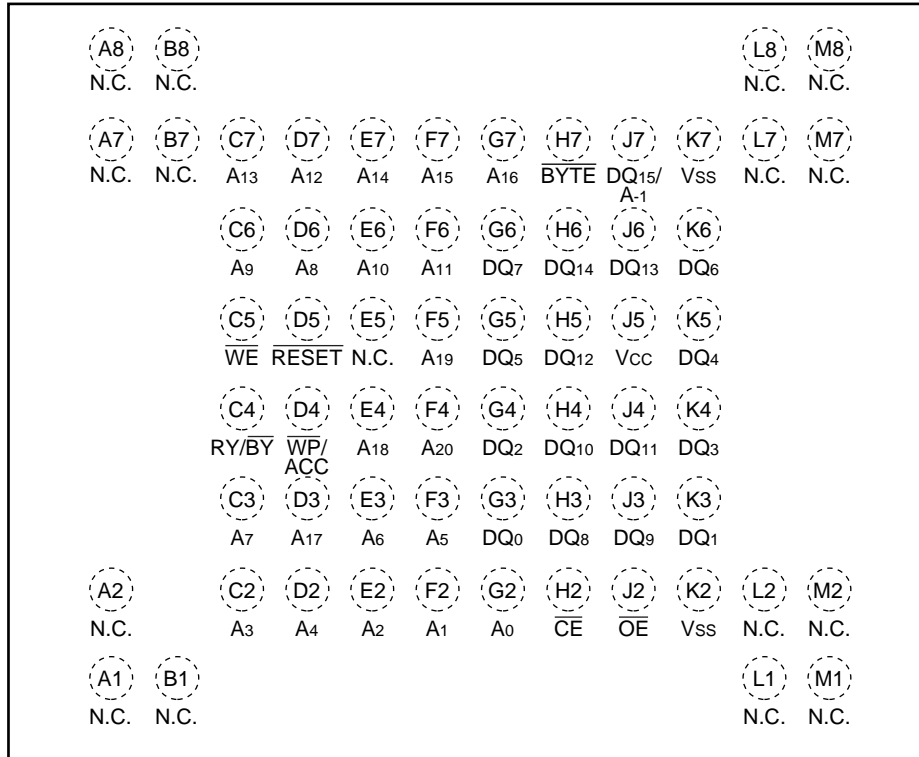

(BGA-63P-M01)

MBM29LV320TE/BE_{80/90/10}

■ PIN DESCRIPTION

MBM29LV320 TE/BE Pin Configuration Table

Pin	Function
A ₂₀ to A ₀ , A ₋₁	Address Inputs
DQ ₁₅ to DQ ₀	Data Inputs/Outputs
$\overline{\text{CE}}$	Chip Enable
$\overline{\text{OE}}$	Output Enable
$\overline{\text{WE}}$	Write Enable
$\overline{\text{RESET}}$	Hardware Reset Pin/Temporary Sector Group Unprotection
RY/ $\overline{\text{BY}}$	Ready/Busy Output
$\overline{\text{BYTE}}$	Selects 8-bit or 16-bit mode
$\overline{\text{WP/ACC}}$	Hardware Write Protection/Program Acceleration
N.C.	No Internal Connection
V _{SS}	Device Ground
V _{CC}	Device Power Supply

■ BLOCK DIAGRAM

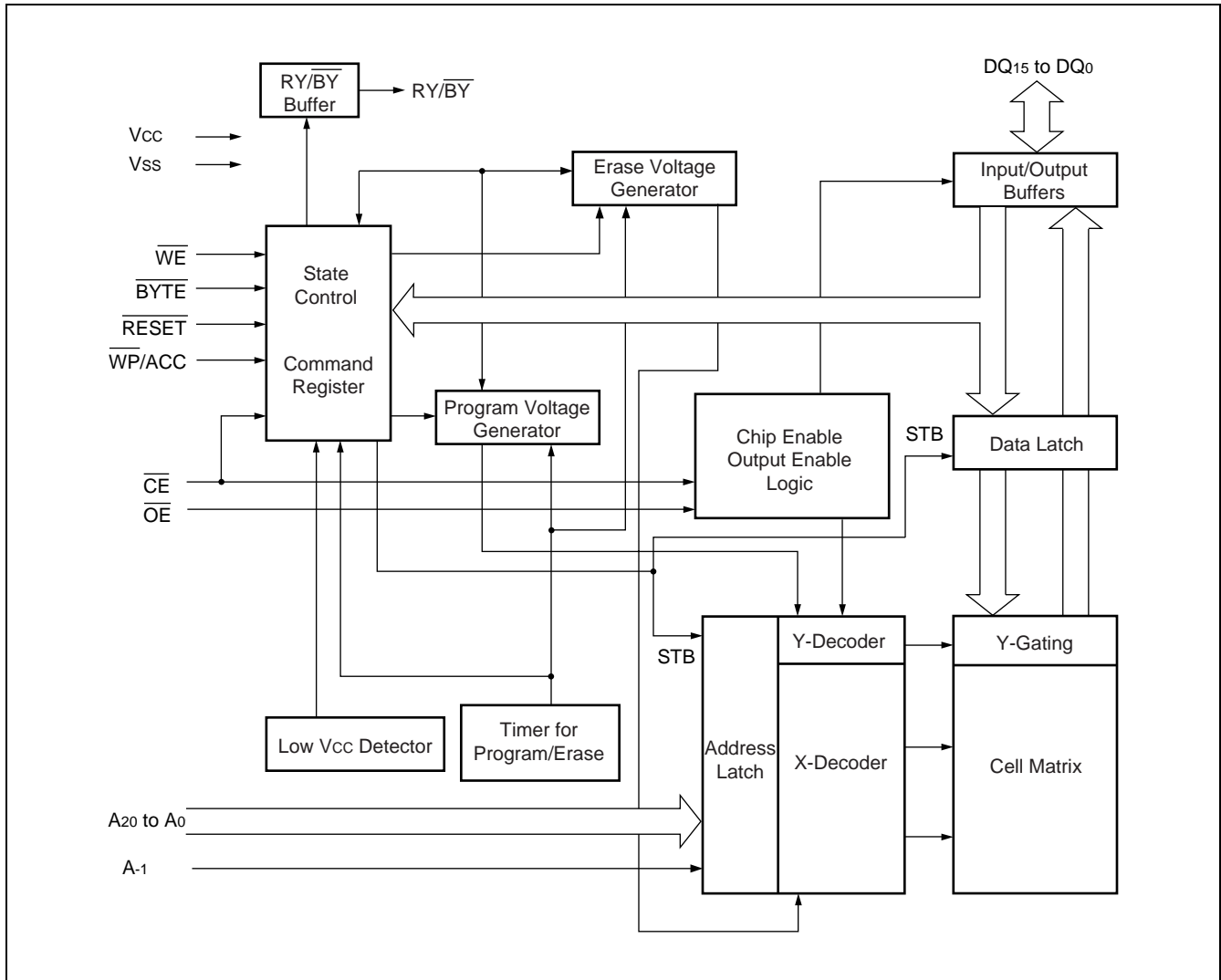

■ LOGIC SYMBOL

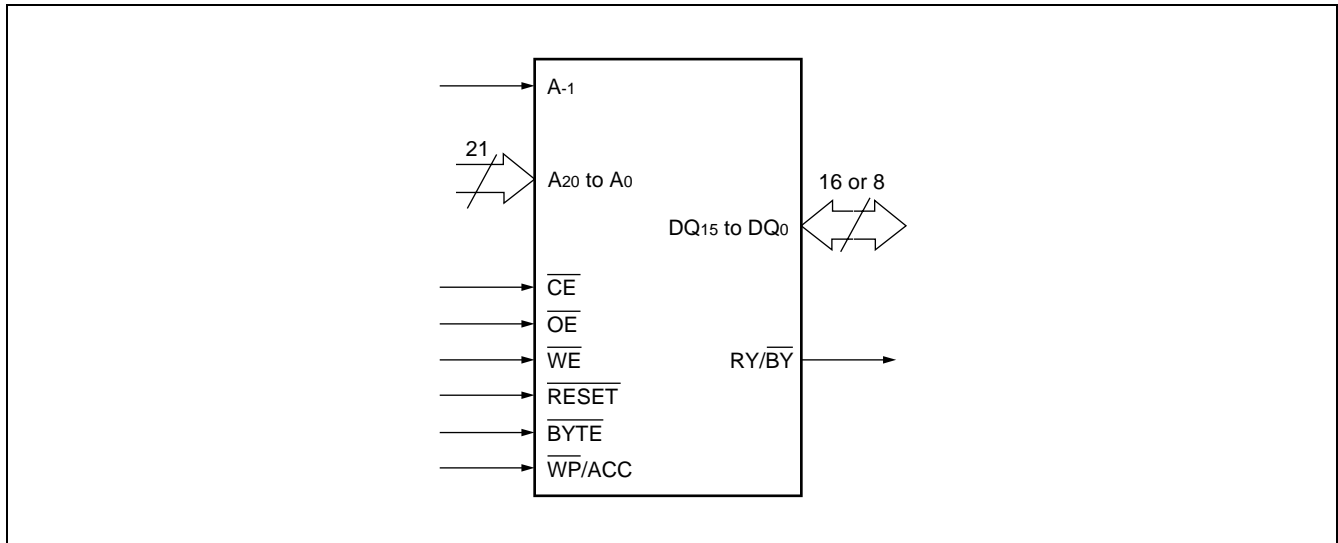

MBM29LV320TE/BE_{80/90/10}

■ DEVICE BUS OPERATION

MBM29LV320TE/BE User Bus Operations Table ($\overline{\text{BYTE}} = V_{IH}$)

Operation	$\overline{\text{CE}}$	$\overline{\text{OE}}$	$\overline{\text{WE}}$	A ₀	A ₁	A ₆	A ₉	DQ ₁₅ to DQ ₀	$\overline{\text{RESET}}$	$\overline{\text{WP/ACC}}$
Auto-Select Manufacturer Code *1	L	L	H	L	L	L	V _{ID}	Code	H	X
Auto-Select Device Code *1	L	L	H	H	L	L	V _{ID}	Code	H	X
Extended Auto-Select Device Code *1	L	L	H	H	H	L	V _{ID}	Code	H	X
Read *3	L	L	H	A ₀	A ₁	A ₆	A ₉	D _{OUT}	H	X
Standby	H	X	X	X	X	X	X	High-Z	H	X
Output Disable	L	H	H	X	X	X	X	High-Z	H	X
Write (Program/Erase)	L	H	L	A ₀	A ₁	A ₆	A ₉	D _{IN}	H	X
Enable Sector Group Protection *2, *4	L	V _{ID}		L	H	L	V _{ID}	X	H	X *6
Verify Sector Group Protection *2, *4	L	L	H	L	H	L	V _{ID}	Code	H	X *6
Temporary Sector Group Unprotection *5	X	X	X	X	X	X	X	X	V _{ID}	X *6
Reset (Hardware) /Standby	X	X	X	X	X	X	X	High-Z	L	X
Boot Block Sector Write Protection	X	X	X	X	X	X	X	X	X	L

Legend : L = V_{IL}, H = V_{IH}, X = V_{IL} or V_{IH},  = Pulse input. See “■DC CHARACTERISTICS” for voltage levels.

*1: Manufacturer and device codes are accessed via a command register write sequence. See “MBM29LV320TE/BE Command Definitions Table”.

*2: See the section on “7. Sector Group Protection” in ■FUNCTIONAL DESCRIPTION.

*3: $\overline{\text{WE}}$ can be V_{IL} if $\overline{\text{OE}}$ is V_{IL}, $\overline{\text{OE}}$ at V_{IH} initiates the write operations.

*4: V_{CC} = 3.3 V ± 10%

*5: Also used for the extended sector group protection.

*6: Conditional exceptions are to be noticed as follows: For MBM29LV320TE (SA22, 23), $\overline{\text{WP/ACC}} = V_{IH}$.
For MBM29LV320BE (SA0, 1), $\overline{\text{WP/ACC}} = V_{IH}$.

MBM29LV320TE/BE_{80/90/10}

MBM29LV320TE/BE User Bus Operations Table ($\overline{\text{BYTE}} = V_{IL}$)

Operation	$\overline{\text{CE}}$	$\overline{\text{OE}}$	$\overline{\text{WE}}$	DQ ₁₅ / A ₋₁	A ₀	A ₁	A ₆	A ₉	DQ ₇ to DQ ₀	$\overline{\text{RESET}}$	$\overline{\text{WP/ACC}}$
Auto-Select Manufacturer Code *1	L	L	H	L	L	L	L	V _{ID}	Code	H	X
Auto-Select Device Code *1	L	L	H	L	H	L	L	V _{ID}	Code	H	X
Extended Auto-Select Device Code *1	L	L	H	L	H	H	L	V _{ID}	Code	H	X
Read *3	L	L	H	A ₋₁	A ₀	A ₁	A ₆	A ₉	D _{OUT}	H	X
Standby	H	X	X	X	X	X	X	X	High-Z	H	X
Output Disable	L	H	H	X	X	X	X	X	High-Z	H	X
Write (Program/Erase)	L	H	L	A ₋₁	A ₀	A ₁	A ₆	A ₉	D _{IN}	H	X
Enable Sector Group Protection *2, *4	L	V _{ID}		L	L	H	L	V _{ID}	X	H	X *6
Verify Sector Group Protection *2, *4	L	L	H	L	L	H	L	V _{ID}	Code	H	X *6
Temporary Sector Group Unprotection *5	X	X	X	X	X	X	X	X	X	V _{ID}	X *6
Reset (Hardware) /Standby	X	X	X	X	X	X	X	X	High-Z	L	X
Boot Block Sector Write Protection	X	X	X	X	X	X	X	X	X	X	L

Legend : L = V_{IL}, H = V_{IH}, X = V_{IL} or V_{IH},  = Pulse input. See “■DC CHARACTERISTICS” for voltage levels.

*1: Manufacturer and device codes may also be accessed via a command register write sequence. See “MBM29LV320TE/BE Command Definitions Table”.

*2: See the section on “7. Sector Group Protection” in ■FUNCTIONAL DESCRIPTION.

*3: $\overline{\text{WE}}$ can be V_{IL} if $\overline{\text{OE}}$ is V_{IL}, $\overline{\text{OE}}$ at V_{IH} initiates the write operations.

*4: V_{CC} = 3.3 V ± 10%

*5: It is also used for the extended sector group protection.

*6: Conditional exceptions are to be noticed as follows: For MBM29LV320TE (SA22, 23), $\overline{\text{WP/ACC}} = V_{IH}$.
For MBM29LV320BE (SA0, 1), $\overline{\text{WP/ACC}} = V_{IH}$.

MBM29LV320TE/BE_{80/90/10}

MBM29LV320TE/BE Command Definitions Table

Command Sequence		Bus Write Cycles Req'd	First Bus Write Cycle		Second Bus Write Cycle		Third Bus Write Cycle		Fourth Bus Read/Write Cycle		Fifth Bus Write Cycle		Sixth Bus Write Cycle	
			Addr.	Data	Addr.	Data	Addr.	Data	Addr.	Data	Addr.	Data	Addr.	Data
Read/Reset ⁶	Word	1	XXXh	F0h	—	—	—	—	—	—	—	—	—	—
	Byte													
Read/Reset ⁶	Word	3	555h	AAh	2AAh	55h	555h	F0h	RA ^{*7}	RD ^{*7}	—	—	—	—
	Byte		AAAh		555h		AAAh							
Autoselect	Word	3	555h	AAh	2AAh	55h	555h	90h	IA ^{*7}	ID ^{*7}	—	—	—	—
	Byte		AAAh		555h		AAAh							
Program	Word	4	555h	AAh	2AAh	55h	555h	A0h	PA	PD	—	—	—	—
	Byte		AAAh		555h		AAAh							
Chip Erase	Word	6	555h	AAh	2AAh	55h	555h	80h	555h	AAh	2AAh	55h	555h	10h
	Byte		AAAh		555h		AAAh		555h		AAAh			
Sector Erase	Word	6	555h	AAh	2AAh	55h	555h	80h	555h	AAh	2AAh	55h	SA	30h
	Byte		AAAh		555h		AAAh		555h		AAAh			
Erase Suspend		1	XXXh	B0h	—	—	—	—	—	—	—	—	—	—
Erase Resume		1	XXXh	30h	—	—	—	—	—	—	—	—	—	—
Set to Fast Mode	Word	3	555h	AAh	2AAh	55h	555h	20h	—	—	—	—	—	—
	Byte		AAAh		555h		AAAh							
Fast Program ^{*1}	Word	2	XXXh	A0h	PA	PD	—	—	—	—	—	—	—	—
	Byte		XXXh											
Reset from Fast Mode ^{*1}	Word	2	XXXh	90h	XXXh	F0h	—	—	—	—	—	—	—	—
	Byte		XXXh											
Extended Sector Group Protection ^{*2}	Word	3	XXXh	60h	SPA	60h	SPA	40h	SPA ^{*7}	SD ^{*7}	—	—	—	—
	Byte													
Query ^{*3}	Word	1	55h	98h	—	—	—	—	—	—	—	—	—	—
	Byte		AAh											
HiddenROM Entry	Word	3	555h	AAh	2AAh	55h	555h	88h	—	—	—	—	—	—
	Byte		AAAh		555h		AAAh							
HiddenROM Program ^{*4}	Word	4	555h	AAh	2AAh	55h	555h	A0h	(HRA) PA	PD	—	—	—	—
	Byte		AAAh		555h		AAAh							
HiddenROM Erase ^{*4}	Word	6	555h	AAh	2AAh	55h	555h	80h	555h	AAh	2AAh	55h	HRA	30h
	Byte		AAAh		555h		AAAh		555h		AAAh			
HiddenROM Exit ^{*4}	Word	4	555h	AAh	2AAh	55h	555h	90h	XXXh	00h	—	—	—	—
	Byte		AAAh		555h		AAAh							

(Continued)

MBM29LV320TE/BE_{80/90/10}

MBM29LV320TE/BE Sector Group Protection Verify Autoselect Codes Table

Type		A ₂₀ to A ₁₂	A ₆	A ₁	A ₀	A ₋₁ *1	Code (HEX)	
Manufacture's Code		Byte	SA	V _{IL}	V _{IL}	V _{IL}	V _{IL}	04h
		Word					X	0004h
Device Code	MBM29LV320TE	Byte	SA	V _{IL}	V _{IL}	V _{IH}	V _{IL}	F6h
		Word					X	22F6h
	MBM29LV320BE	Byte	SA	V _{IL}	V _{IL}	V _{IH}	V _{IL}	F9h
		Word					X	22F9h
Extend Device Code	MBM29LV320TE/BE	Byte	SA	V _{IL}	V _{IH}	V _{IH}	V _{IL}	19h
		Word					X	0019h
Sector Group Protection		Byte	Sector Group Addresses	V _{IL}	V _{IH}	V _{IL}	V _{IL}	01h*2
		Word					X	0001h*2

*1 : A₋₁ is for byte mode. At byte mode, DQ₁₄ to DQ₈ are High-Z and DQ₁₅ is A₋₁, the lowest address.

*2 : Outputs 01h at protected sector group addresses and outputs 00h at unprotected sector group addresses.

Extended Autoselect Code Table

Type		Code	DQ ₁₅	DQ ₁₄	DQ ₁₃	DQ ₁₂	DQ ₁₁	DQ ₁₀	DQ ₉	DQ ₈	DQ ₇	DQ ₆	DQ ₅	DQ ₄	DQ ₃	DQ ₂	DQ ₁	DQ ₀	
Manufacturer's Code	(B)*	04h	A ₋₁	HZ	HZ	HZ	HZ	HZ	HZ	HZ	0	0	0	0	0	1	0	0	
	(W)	0004h	0	0	0	0	0	0	0	0	0	0	0	0	0	1	0	0	
Device Code	MBM29LV320TE	(B)*	F6h	A ₋₁	HZ	HZ	HZ	HZ	HZ	HZ	1	1	1	1	0	1	1	0	
		(W)	22F6h	0	0	1	0	0	0	1	0	1	1	1	1	0	1	1	0
	MBM29LV320BE	(B)*	F9h	A ₋₁	HZ	HZ	HZ	HZ	HZ	HZ	1	1	1	1	1	0	0	0	1
		(W)	22F9h	0	0	1	0	0	0	1	0	1	1	1	1	1	0	0	1
Extend Device Code	MBM29LV320TE/BE	(B)*	19h	A ₋₁	HZ	HZ	HZ	HZ	HZ	HZ	0	0	0	1	1	0	0	1	
		(W)	0019h	0	0	0	0	0	0	0	0	0	0	1	1	0	0	1	
Sector Group Protection	(B)*	01h	A ₋₁	HZ	HZ	HZ	HZ	HZ	HZ	HZ	0	0	0	0	0	0	0	1	
	(W)	0001h	0	0	0	0	0	0	0	0	0	0	0	0	0	0	0	1	

(B) : Byte mode
(W) : Word mode
HZ: High-Z

* : At byte mode, DQ₁₄ to DQ₈ are High-Z and DQ₁₅ is A₋₁, the lowest address.

■ FLEXIBLE SECTOR-ERASE ARCHITECTURE

Sector Address Table (MBM29LV320TE)

Sector	Sector Address										Sector Size (Kbytes/ Kwords)	(x8) Address Range	(x16) Address Range
	A ₂₀	A ₁₉	A ₁₈	A ₁₇	A ₁₆	A ₁₅	A ₁₄	A ₁₃	A ₁₂	A ₁₁			
SA0	0	0	0	0	0	0	X	X	X	X	64/32	000000h to 00FFFFh	000000h to 007FFFh
SA1	0	0	0	0	0	1	X	X	X	X	64/32	010000h to 01FFFFh	008000h to 00FFFFh
SA2	0	0	0	0	1	0	X	X	X	X	64/32	020000h to 02FFFFh	010000h to 017FFFh
SA3	0	0	0	0	1	1	X	X	X	X	64/32	030000h to 03FFFFh	018000h to 01FFFFh
SA4	0	0	0	1	0	0	X	X	X	X	64/32	040000h to 04FFFFh	020000h to 027FFFh
SA5	0	0	0	1	0	1	X	X	X	X	64/32	050000h to 05FFFFh	028000h to 02FFFFh
SA6	0	0	0	1	1	0	X	X	X	X	64/32	060000h to 06FFFFh	030000h to 037FFFh
SA7	0	0	0	1	1	1	X	X	X	X	64/32	070000h to 07FFFFh	038000h to 03FFFFh
SA8	0	0	1	0	0	0	X	X	X	X	64/32	080000h to 08FFFFh	040000h to 047FFFh
SA9	0	0	1	0	0	1	X	X	X	X	64/32	090000h to 09FFFFh	048000h to 04FFFFh
SA10	0	0	1	0	1	0	X	X	X	X	64/32	0A0000h to 0AFFFFh	050000h to 057FFFh
SA11	0	0	1	0	1	1	X	X	X	X	64/32	0B0000h to 0BFFFFh	058000h to 05FFFFh
SA12	0	0	1	1	0	0	X	X	X	X	64/32	0C0000h to 0CFFFFh	060000h to 067FFFh
SA13	0	0	1	1	0	1	X	X	X	X	64/32	0D0000h to 0DFFFFh	068000h to 06FFFFh
SA14	0	0	1	1	1	0	X	X	X	X	64/32	0E0000h to 0EFFFFh	070000h to 077FFFh
SA15	0	0	1	1	1	1	X	X	X	X	64/32	0F0000h to 0FFFFFFh	078000h to 07FFFFh
SA16	0	1	0	0	0	0	X	X	X	X	64/32	100000h to 10FFFFh	080000h to 087FFFh
SA17	0	1	0	0	0	1	X	X	X	X	64/32	110000h to 11FFFFh	088000h to 08FFFFh
SA18	0	1	0	0	1	0	X	X	X	X	64/32	120000h to 12FFFFh	090000h to 097FFFh
SA19	0	1	0	0	1	1	X	X	X	X	64/32	130000h to 13FFFFh	098000h to 09FFFFh
SA20	0	1	0	1	0	0	X	X	X	X	64/32	140000h to 14FFFFh	0A0000h to 0A7FFFh
SA21	0	1	0	1	0	1	X	X	X	X	64/32	150000h to 15FFFFh	0A8000h to 0AFFFFh
SA22	0	1	0	1	1	0	X	X	X	X	64/32	160000h to 16FFFFh	0B0000h to 0B7FFFh
SA23	0	1	0	1	1	1	X	X	X	X	64/32	170000h to 17FFFFh	0B8000h to 0BFFFFh
SA24	0	1	1	0	0	0	X	X	X	X	64/32	180000h to 18FFFFh	0C0000h to 0C7FFFh
SA25	0	1	1	0	0	1	X	X	X	X	64/32	190000h to 19FFFFh	0C8000h to 0CFFFFh
SA26	0	1	1	0	1	0	X	X	X	X	64/32	1A0000h to 1AFFFFh	0D0000h to 0D7FFFh
SA27	0	1	1	0	1	1	X	X	X	X	64/32	1B0000h to 1BFFFFh	0D8000h to 0DFFFFh
SA28	0	1	1	1	0	0	X	X	X	X	64/32	1C0000h to 1CFFFFh	0E0000h to 0E7FFFh
SA29	0	1	1	1	0	1	X	X	X	X	64/32	1D0000h to 1DFFFFh	0E8000h to 0EFFFFh
SA30	0	1	1	1	1	0	X	X	X	X	64/32	1E0000h to 1EFFFFh	0F0000h to 0F7FFFh
SA31	0	1	1	1	1	1	X	X	X	X	64/32	1F0000h to 1FFFFFFh	0F8000h to 0FFFFFFh

(Continued)

MBM29LV320TE/BE_{80/90/10}

Sector	Sector Address										Sector Size (Kbytes/ Kwords)	(×8) Address Range	(×16) Address Range
	A ₂₀	A ₁₉	A ₁₈	A ₁₇	A ₁₆	A ₁₅	A ₁₄	A ₁₃	A ₁₂	A ₁₁			
SA32	1	0	0	0	0	0	X	X	X	X	64/32	200000h to 20FFFFh	100000h to 107FFFh
SA33	1	0	0	0	0	1	X	X	X	X	64/32	210000h to 21FFFFh	108000h to 10FFFFh
SA34	1	0	0	0	1	0	X	X	X	X	64/32	220000h to 22FFFFh	110000h to 117FFFh
SA35	1	0	0	0	1	1	X	X	X	X	64/32	230000h to 23FFFFh	118000h to 11FFFFh
SA36	1	0	0	1	0	0	X	X	X	X	64/32	240000h to 24FFFFh	120000h to 127FFFh
SA37	1	0	0	1	0	1	X	X	X	X	64/32	250000h to 25FFFFh	128000h to 12FFFFh
SA38	1	0	0	1	1	0	X	X	X	X	64/32	260000h to 26FFFFh	130000h to 137FFFh
SA39	1	0	0	1	1	1	X	X	X	X	64/32	270000h to 27FFFFh	138000h to 13FFFFh
SA40	1	0	1	0	0	0	X	X	X	X	64/32	280000h to 28FFFFh	140000h to 147FFFh
SA41	1	0	1	0	0	1	X	X	X	X	64/32	290000h to 29FFFFh	148000h to 14FFFFh
SA42	1	0	1	0	1	0	X	X	X	X	64/32	2A0000h to 2AFFFFh	150000h to 157FFFh
SA43	1	0	1	0	1	1	X	X	X	X	64/32	2B0000h to 2BFFFFh	158000h to 15FFFFh
SA44	1	0	1	1	0	0	X	X	X	X	64/32	2C0000h to 2CFFFFh	160000h to 167FFFh
SA45	1	0	1	1	0	1	X	X	X	X	64/32	2D0000h to 2DFFFFh	168000h to 16FFFFh
SA46	1	0	1	1	1	0	X	X	X	X	64/32	2E0000h to 2EFFFFh	170000h to 177FFFh
SA47	1	0	1	1	1	1	X	X	X	X	64/32	2F0000h to 2FFFFFh	178000h to 17FFFFh
SA48	1	1	0	0	0	0	X	X	X	X	64/32	300000h to 30FFFFh	180000h to 187FFFh
SA49	1	1	0	0	0	1	X	X	X	X	64/32	310000h to 31FFFFh	188000h to 18FFFFh
SA50	1	1	0	0	1	0	X	X	X	X	64/32	320000h to 32FFFFh	190000h to 197FFFh
SA51	1	1	0	0	1	1	X	X	X	X	64/32	330000h to 33FFFFh	198000h to 19FFFFh
SA52	1	1	0	1	0	0	X	X	X	X	64/32	340000h to 34FFFFh	1A0000h to 1A7FFFh
SA53	1	1	0	1	0	1	X	X	X	X	64/32	350000h to 35FFFFh	1A8000h to 1AFFFFh
SA54	1	1	0	1	1	0	X	X	X	X	64/32	360000h to 36FFFFh	1B0000h to 1B7FFFh
SA55	1	1	0	1	1	1	X	X	X	X	64/32	370000h to 37FFFFh	1B8000h to 1BFFFFh
SA56	1	1	1	0	0	0	X	X	X	X	64/32	380000h to 38FFFFh	1C0000h to 1C7FFFh
SA57	1	1	1	0	0	1	X	X	X	X	64/32	390000h to 39FFFFh	1C8000h to 1CFFFFh
SA58	1	1	1	0	1	0	X	X	X	X	64/32	3A0000h to 3AFFFFh	1D0000h to 1D7FFFh
SA59	1	1	1	0	1	1	X	X	X	X	64/32	3B0000h to 3BFFFFh	1D8000h to 1DFFFFh
SA60	1	1	1	1	0	0	X	X	X	X	64/32	3C0000h to 3CFFFFh	1E0000h to 1E7FFFh
SA61	1	1	1	1	0	1	X	X	X	X	64/32	3D0000h to 3DFFFFh	1E8000h to 1EFFFFh
SA62	1	1	1	1	1	0	X	X	X	X	64/32	3E0000h to 3EFFFFh	1F0000h to 1F7FFFh
SA63	1	1	1	1	1	1	0	0	0	X	8/4	3F0000h to 3F1FFFh	1F8000h to 1F8FFFh
SA64	1	1	1	1	1	1	0	0	1	X	8/4	3F2000h to 3F3FFFh	1F9000h to 1F9FFFh

(Continued)

MBM29LV320TE/BE_{80/90/10}

(Continued)

Sector	Sector Address										Sector Size (Kbytes/ Kwords)	(×8) Address Range	(×16) Address Range
	A ₂₀	A ₁₉	A ₁₈	A ₁₇	A ₁₆	A ₁₅	A ₁₄	A ₁₃	A ₁₂	A ₁₁			
SA65	1	1	1	1	1	1	0	1	0	X	8/4	3F4000h to 3F5FFFh	1FA000h to 1FAFFFh
SA66	1	1	1	1	1	1	0	1	1	X	8/4	3F6000h to 3F7FFFh	1FB000h to 1FBFFFh
SA67	1	1	1	1	1	1	1	0	0	X	8/4	3F8000h to 3F9FFFh	1FC000h to 1FCFFFh
SA68	1	1	1	1	1	1	1	0	1	X	8/4	3FA000h to 3FBFFFh	1FD000h to 1FDFFFh
SA69	1	1	1	1	1	1	1	1	0	X	8/4	3FC000h to 3FDFFFh	1FE000h to 1FEFFFh
SA70	1	1	1	1	1	1	1	1	1	X	8/4	3FE000h to 3FFFFFh	1FF000h to 1FFFFFFh

Note : The address range is A₂₀ : A₋₁ if in byte mode ($\overline{\text{BYTE}} = V_{IL}$).
 The address range is A₂₀ : A₀ if in word mode ($\text{BYTE} = V_{IH}$).

MBM29LV320TE/BE_{80/90/10}

Sector Address Table (MBM29LV320BE)

Sector	Sector Address										Sector Size (Kbytes/ Kwords)	(x8) Address Range	(x16) Address Range
	A ₂₀	A ₁₉	A ₁₈	A ₁₇	A ₁₆	A ₁₅	A ₁₄	A ₁₃	A ₁₂	A ₁₁			
SA70	1	1	1	1	1	1	X	X	X	X	64/32	3F0000h to 3FFFFFFh	1F8000h to 1FFFFFFh
SA69	1	1	1	1	1	0	X	X	X	X	64/32	3E0000h to 3FFFFFFh	1F0000h to 1F7FFFh
SA68	1	1	1	1	0	1	X	X	X	X	64/32	3D0000h to 3FFFFFFh	1E8000h to 1EFFFFh
SA67	1	1	1	1	0	0	X	X	X	X	64/32	3C0000h to 3FFFFFFh	1E0000h to 1E7FFFh
SA66	1	1	1	0	1	1	X	X	X	X	64/32	3B0000h to 3FFFFFFh	1D8000h to 1DFFFFh
SA65	1	1	1	0	1	0	X	X	X	X	64/32	3A0000h to 3FFFFFFh	1D0000h to 1D7FFFh
SA64	1	1	1	0	0	1	X	X	X	X	64/32	390000h to 39FFFFh	1C8000h to 1CFFFFh
SA63	1	1	1	0	0	0	X	X	X	X	64/32	380000h to 38FFFFh	1C0000h to 1C7FFFh
SA62	1	1	0	1	1	1	X	X	X	X	64/32	370000h to 37FFFFh	1B8000h to 1BFFFFh
SA61	1	1	0	1	1	0	X	X	X	X	64/32	360000h to 36FFFFh	1B0000h to 1B7FFFh
SA60	1	1	0	1	0	1	X	X	X	X	64/32	350000h to 35FFFFh	1A8000h to 1AFFFFh
SA59	1	1	0	1	0	0	X	X	X	X	64/32	340000h to 34FFFFh	1A0000h to 1A7FFFh
SA58	1	1	0	0	1	1	X	X	X	X	64/32	330000h to 33FFFFh	198000h to 19FFFFh
SA57	1	1	0	0	1	0	X	X	X	X	64/32	320000h to 32FFFFh	190000h to 197FFFh
SA56	1	1	0	0	0	1	X	X	X	X	64/32	310000h to 31FFFFh	188000h to 18FFFFh
SA55	1	1	0	0	0	0	X	X	X	X	64/32	300000h to 30FFFFh	180000h to 187FFFh
SA54	1	0	1	1	1	1	X	X	X	X	64/32	2F0000h to 2FFFFFFh	178000h to 17FFFFh
SA53	1	0	1	1	1	0	X	X	X	X	64/32	2E0000h to 2FFFFFFh	170000h to 177FFFh
SA52	1	0	1	1	0	1	X	X	X	X	64/32	2D0000h to 2DFFFFh	168000h to 16FFFFh
SA51	1	0	1	1	0	0	X	X	X	X	64/32	2C0000h to 2CFFFFh	160000h to 167FFFh
SA50	1	0	1	0	1	1	X	X	X	X	64/32	2B0000h to 2BFFFFh	158000h to 15FFFFh
SA49	1	0	1	0	1	0	X	X	X	X	64/32	2A0000h to 2AFFFFh	150000h to 157FFFh
SA48	1	0	1	0	0	1	X	X	X	X	64/32	290000h to 29FFFFh	148000h to 14FFFFh
SA47	1	0	1	0	0	0	X	X	X	X	64/32	280000h to 28FFFFh	140000h to 147FFFh
SA46	1	0	0	1	1	1	X	X	X	X	64/32	270000h to 27FFFFh	138000h to 13FFFFh
SA45	1	0	0	1	1	0	X	X	X	X	64/32	260000h to 26FFFFh	130000h to 137FFFh
SA44	1	0	0	1	0	1	X	X	X	X	64/32	250000h to 25FFFFh	128000h to 12FFFFh
SA43	1	0	0	1	0	0	X	X	X	X	64/32	240000h to 24FFFFh	120000h to 127FFFh
SA42	1	0	0	0	1	1	X	X	X	X	64/32	230000h to 23FFFFh	118000h to 11FFFFh
SA41	1	0	0	0	1	0	X	X	X	X	64/32	220000h to 22FFFFh	110000h to 117FFFh
SA40	1	0	0	0	0	1	X	X	X	X	64/32	210000h to 21FFFFh	108000h to 10FFFFh
SA39	1	0	0	0	0	0	X	X	X	X	64/32	200000h to 20FFFFh	100000h to 107FFFh
SA38	0	1	1	1	1	1	X	X	X	X	64/32	1F0000h to 1FFFFFFh	0F8000h to 0FFFFFFh

(Continued)

MBM29LV320TE/BE_{80/90/10}

Sector	Sector Address										Sector Size (Kbytes/ Kwords)	(×8) Address Range	(×16) Address Range
	A ₂₀	A ₁₉	A ₁₈	A ₁₇	A ₁₆	A ₁₅	A ₁₄	A ₁₃	A ₁₂	A ₁₁			
SA37	0	1	1	1	1	0	X	X	X	X	64/32	1E0000h to 1EFFFFh	0F0000h to 0F7FFFh
SA36	0	1	1	1	0	1	X	X	X	X	64/32	1D0000h to 1DFFFFh	0E8000h to 0EFFFFh
SA35	0	1	1	1	0	0	X	X	X	X	64/32	1C0000h to 1CFFFFh	0E0000h to 0E7FFFh
SA34	0	1	1	0	1	1	X	X	X	X	64/32	1B0000h to 1BFFFFh	0D8000h to 0DFFFFh
SA33	0	1	1	0	1	0	X	X	X	X	64/32	1A0000h to 1AFFFFh	0D0000h to 0D7FFFh
SA32	0	1	1	0	0	1	X	X	X	X	64/32	190000h to 19FFFFh	0C8000h to 0CFFFFh
SA31	0	1	1	0	0	0	X	X	X	X	64/32	180000h to 18FFFFh	0C0000h to 0C7FFFh
SA30	0	1	0	1	1	1	X	X	X	X	64/32	170000h to 17FFFFh	0B8000h to 0BFFFFh
SA29	0	1	0	1	1	0	X	X	X	X	64/32	160000h to 16FFFFh	0B0000h to 0B7FFFh
SA28	0	1	0	1	0	1	X	X	X	X	64/32	150000h to 15FFFFh	0A8000h to 0AFFFFh
SA27	0	1	0	1	0	0	X	X	X	X	64/32	140000h to 14FFFFh	0A0000h to 0A7FFFh
SA26	0	1	0	0	1	1	X	X	X	X	64/32	130000h to 13FFFFh	098000h to 09FFFFh
SA25	0	1	0	0	1	0	X	X	X	X	64/32	120000h to 12FFFFh	090000h to 097FFFh
SA24	0	1	0	0	0	1	X	X	X	X	64/32	110000h to 11FFFFh	088000h to 08FFFFh
SA23	0	1	0	0	0	0	X	X	X	X	64/32	100000h to 10FFFFh	080000h to 087FFFh
SA22	0	0	1	1	1	1	X	X	X	X	64/32	0F0000h to 0FFFFFh	078000h to 07FFFFh
SA21	0	0	1	1	1	0	X	X	X	X	64/32	0E0000h to 0EFFFFh	070000h to 077FFFh
SA20	0	0	1	1	0	1	X	X	X	X	64/32	0D0000h to 0DFFFFh	068000h to 06FFFFh
SA19	0	0	1	1	0	0	X	X	X	X	64/32	0C0000h to 0CFFFFh	060000h to 067FFFh
SA18	0	0	1	0	1	1	X	X	X	X	64/32	0B0000h to 0BFFFFh	058000h to 05FFFFh
SA17	0	0	1	0	1	0	X	X	X	X	64/32	0A0000h to 0AFFFFh	050000h to 057FFFh
SA16	0	0	1	0	0	1	X	X	X	X	64/32	090000h to 09FFFFh	048000h to 04FFFFh
SA15	0	0	1	0	0	0	X	X	X	X	64/32	080000h to 08FFFFh	040000h to 047FFFh
SA14	0	0	0	1	1	1	X	X	X	X	64/32	070000h to 07FFFFh	038000h to 03FFFFh
SA13	0	0	0	1	1	0	X	X	X	X	64/32	060000h to 06FFFFh	030000h to 037FFFh
SA12	0	0	0	1	0	1	X	X	X	X	64/32	050000h to 05FFFFh	028000h to 02FFFFh
SA11	0	0	0	1	0	0	X	X	X	X	64/32	040000h to 04FFFFh	020000h to 027FFFh
SA10	0	0	0	0	1	1	X	X	X	X	64/32	030000h to 03FFFFh	018000h to 01FFFFh
SA9	0	0	0	0	1	0	X	X	X	X	64/32	020000h to 02FFFFh	010000h to 017FFFh
SA8	0	0	0	0	0	1	X	X	X	X	64/32	010000h to 01FFFFh	008000h to 00FFFFh
SA7	0	0	0	0	0	0	1	1	1	X	8/4	00E000h to 00FFFFh	007000h to 007FFFh
SA6	0	0	0	0	0	0	1	1	0	X	8/4	00C000h to 00DFFFh	006000h to 006FFFh
SA5	0	0	0	0	0	0	1	0	1	X	8/4	00A000h to 00BFFFh	005000h to 005FFFh

(Continued)

MBM29LV320TE/BE_{80/90/10}

(Continued)

Sector	Sector Address										Sector Size (Kbytes/ Kwords)	(×8) Address Range	(×16) Address Range
	A ₂₀	A ₁₉	A ₁₈	A ₁₇	A ₁₆	A ₁₅	A ₁₄	A ₁₃	A ₁₂	A ₁₁			
SA4	0	0	0	0	0	0	1	0	0	X	8/4	008000h to 009FFFh	004000h to 004FFFh
SA3	0	0	0	0	0	0	0	1	1	X	8/4	006000h to 007FFFh	003000h to 003FFFh
SA2	0	0	0	0	0	0	0	1	0	X	8/4	004000h to 005FFFh	002000h to 002FFFh
SA1	0	0	0	0	0	0	0	0	1	X	8/4	002000h to 003FFFh	001000h to 001FFFh
SA0	0	0	0	0	0	0	0	0	0	X	8/4	000000h to 001FFFh	000000h to 000FFFh

Note : The address range is A₂₀ : A₋₁ if in byte mode ($\overline{\text{BYTE}} = V_{IL}$).
 The address range is A₂₀ : A₀ if in word mode ($\overline{\text{BYTE}} = V_{IH}$).

MBM29LV320TE/BE_{80/90/10}

**Sector Group Address Table (MBM29LV320TE)
(Top Boot Block)**

Sector Group	A ₂₀	A ₁₉	A ₁₈	A ₁₇	A ₁₆	A ₁₅	A ₁₄	A ₁₃	A ₁₂	Sectors
SGA0	0	0	0	0	X	X	X	X	X	SA0 to SA3
SGA1	0	0	0	1	X	X	X	X	X	SA4 to SA7
SGA2	0	0	1	0	X	X	X	X	X	SA8 to SA11
SGA3	0	0	1	1	X	X	X	X	X	SA12 to SA15
SGA4	0	1	0	0	X	X	X	X	X	SA16 to SA19
SGA5	0	1	0	1	X	X	X	X	X	SA20 to SA23
SGA6	0	1	1	0	X	X	X	X	X	SA24 to SA27
SGA7	0	1	1	1	X	X	X	X	X	SA28 to SA31
SGA8	1	0	0	0	X	X	X	X	X	SA32 to SA35
SGA9	1	0	0	1	X	X	X	X	X	SA36 to SA39
SGA10	1	0	1	0	X	X	X	X	X	SA40 to SA43
SGA11	1	0	1	1	X	X	X	X	X	SA44 to SA47
SGA12	1	1	0	0	X	X	X	X	X	SA48 to SA51
SGA13	1	1	0	1	X	X	X	X	X	SA52 to SA55
SGA14	1	1	1	0	X	X	X	X	X	SA56 to SA59
SGA15	1	1	1	1	0	0	X	X	X	SA60 to SA62
					0	1				
					1	0				
SGA16	1	1	1	1	1	1	0	0	0	SA63
SGA17	1	1	1	1	1	1	0	0	1	SA64
SGA18	1	1	1	1	1	1	0	1	0	SA65
SGA19	1	1	1	1	1	1	0	1	1	SA66
SGA20	1	1	1	1	1	1	1	0	0	SA67
SGA21	1	1	1	1	1	1	1	0	1	SA68
SGA22	1	1	1	1	1	1	1	1	0	SA69
SGA23	1	1	1	1	1	1	1	1	1	SA70

MBM29LV320TE/BE_{80/90/10}

**Sector Group Address Table (MBM29LV320BE)
(Bottom Boot Block)**

Sector Group	A ₂₀	A ₁₉	A ₁₈	A ₁₇	A ₁₆	A ₁₅	A ₁₄	A ₁₃	A ₁₂	Sectors
SGA0	0	0	0	0	0	0	0	0	0	SA0
SGA1	0	0	0	0	0	0	0	0	1	SA1
SGA2	0	0	0	0	0	0	0	1	0	SA2
SGA3	0	0	0	0	0	0	0	1	1	SA3
SGA4	0	0	0	0	0	0	1	0	0	SA4
SGA5	0	0	0	0	0	0	1	0	1	SA5
SGA6	0	0	0	0	0	0	1	1	0	SA6
SGA7	0	0	0	0	0	0	1	1	1	SA7
SGA8	0	0	0	0	0	1	X	X	X	SA8 to SA10
					1	0				
					1	1				
SGA9	0	0	0	1	X	X	X	X	X	SA11 to SA14
SGA10	0	0	1	0	X	X	X	X	X	SA15 to SA18
SGA11	0	0	1	1	X	X	X	X	X	SA19 to SA22
SGA12	0	1	0	0	X	X	X	X	X	SA23 to SA26
SGA13	0	1	0	1	X	X	X	X	X	SA27 to SA30
SGA14	0	1	1	0	X	X	X	X	X	SA31 to SA34
SGA15	0	1	1	1	X	X	X	X	X	SA35 to SA38
SGA16	1	0	0	0	X	X	X	X	X	SA39 to SA42
SGA17	1	0	0	1	X	X	X	X	X	SA43 to SA46
SGA18	1	0	1	0	X	X	X	X	X	SA47 to SA50
SGA19	1	0	1	1	X	X	X	X	X	SA51 to SA54
SGA20	1	1	0	0	X	X	X	X	X	SA55 to SA58
SGA21	1	1	0	1	X	X	X	X	X	SA59 to SA62
SGA22	1	1	1	0	X	X	X	X	X	SA63 to SA66
SGA23	1	1	1	1	X	X	X	X	X	SA67 to SA70

Common Flash Memory Interface Code Table

Description	A ₆ to A ₀	DQ ₁₅ to DQ ₀
Query-unique ASCII string "QRY"	10h 11h 12h	0051h 0052h 0059h
Primary OEM Command Set 02h : AMD/FJ standard type	13h 14h	0002h 0000h
Address for Primary Extended Table	15h 16h	0040h 0000h
Alternate OEM Command Set (00h = not applicable)	17h 18h	0000h 0000h
Address for Alternate OEM Extended Table	19h 1Ah	0000h 0000h
V _{CC} Min Voltage (write/erase) DQ ₇ to DQ ₄ : 1 V, DQ ₃ to DQ ₀ : 100 mV	1Bh	0027h
V _{CC} Max (write/erase) DQ ₇ to DQ ₄ : 1 V, DQ ₃ to DQ ₀ : 100 mV	1Ch	0036h
V _{PP} Min voltage	1Dh	0000h
V _{PP} Max voltage	1Eh	0000h
Typical timeout per single byte/word write 2 ^N μs	1Fh	0004h
Typical timeout for Min size buffer write 2 ^N μs	20h	0000h
Typical timeout per individual sector erase 2 ^N ms	21h	000Ah
Typical timeout for full chip erase 2 ^N ms	22h	0000h
Max timeout for byte/word write 2 ^N times typical	23h	0005h
Max timeout for buffer write 2 ^N times typical	24h	0000h
Max timeout per individual sector erase 2 ^N times typical	25h	0004h
Max timeout for full chip erase 2 ^N times typical	26h	0000h
Device Size = 2 ^N byte	27h	0016h
Flash Device Interface description 02h : ×8/×16	28h 29h	0002h 0000h
Max number of byte in multi-byte write = 2 ^N	2Ah 2Bh	0000h 0000h
Number of Erase Block Regions within device	2Ch	0002h
Erase Block Region 1 Information	2Dh 2Eh 2Fh 30h	0007h 0000h 0020h 0000h
Erase Block Region 2 Information	31h 32h 33h 34h	003Eh 0000h 0000h 0001h

(Continued)

MBM29LV320TE/BE_{80/90/10}

(Continued)

Description	A ₆ to A ₀	DQ ₁₅ to DQ ₀
Query-unique ASCII string "PRI"	40h 41h 42h	0050h 0052h 0049h
Major version number, ASCII	43h	0031h
Minor version number, ASCII	44h	0031h
Address Sensitive Unlock 00h = Required	45h	0000h
Erase Suspend 02h = To Read & Write	46h	0002h
Sector Protection X = Number of sectors in per group	47h	0004h
Sector Temporary Unprotection 01h = Supported	48h	0001h
Sector Protection Algorithm	49h	0004h
Number of Sector for Bank 2 00h = Not Supported	4Ah	0000h
Burst Mode Type 00h = Not Supported	4Bh	0000h
Page Mode Type 00h = Not Supported	4Ch	0000h
V _{ACC} (Acceleration) Supply Minimum DQ ₇ to DQ ₄ : 1 V, DQ ₃ to DQ ₀ : 100 mV	4Dh	00B5h
V _{ACC} (Acceleration) Supply Maximum DQ ₇ to DQ ₄ : 1 V, DQ ₃ to DQ ₀ : 100 mV	4Eh	00C5h
Boot Type 02h = MBM29LV320BE 03h = MBM29LV320TE	4Fh	00XXh

■ FUNCTIONAL DESCRIPTION

1. Read Mode

The device has two control functions which must be satisfied in order to obtain data at the outputs. \overline{CE} is the power control and should be used for a device selection. \overline{OE} is the output control and used to gate data to the output pins if a device is selected.

Address access time (t_{ACC}) is equal to the delay from stable addresses to valid output data. The chip enable access time (t_{CE}) is the delay from stable addresses and stable \overline{CE} to valid data at the output pins. The output enable access time is the delay from the falling edge of \overline{OE} to valid data at the output pins. Assuming the addresses have been stable for at least $t_{ACC-tOE}$ time. When reading out data without changing addresses after power-up, input hardware reset or to change \overline{CE} pin from "H" or "L".

2. Standby Mode

There are two ways to implement the standby mode on the device, one using both the \overline{CE} and \overline{RESET} pins; the other via the \overline{RESET} pin only.

When using both pins, CMOS standby mode is achieved with \overline{CE} and \overline{RESET} inputs both held at $V_{CC} \pm 0.3 V$. Under this condition the current consumed is less than 5 μA Max During Embedded Algorithm operation, V_{CC} active current (I_{CC2}) is required even when $\overline{CE} = "H"$. The device can be read with standard access time (t_{CE}) from either of these standby modes.

When using the \overline{RESET} pin only, CMOS standby mode is achieved with \overline{RESET} input held at $V_{SS} \pm 0.3 V$ ($\overline{CE} = "H"$ or "L"). Under this condition the current consumed is less than 5 μA Max Once the \overline{RESET} pin is taken high, the device requires t_{RH} as wake up time for outputs to be valid for read access.

In the standby mode the outputs are in the high impedance state independently of the \overline{OE} input.

3. Automatic Sleep Mode

There is a function called automatic sleep mode to restrain power consumption during read-out of the device data. This mode can be useful in the application such as a handy terminal which requires low power consumption.

To activate this mode, the device automatically switches themselves to low power mode when the device addresses remain stable during access time of 150 ns. It is not necessary to control \overline{CE} , \overline{WE} , and \overline{OE} on the mode. Under the mode, the current consumed is typically 1 μA (CMOS Level).

During simultaneous operation, V_{CC} active current (I_{CC2}) is required.

Since the data are latched during this mode, the data are read-out continuously. If the addresses are changed, the mode is canceled automatically, and the device read the data for changed addresses.

4. Output Disable

With the \overline{OE} input at logic high level (V_{IH}), output from the device is disabled. This will causes the output pins to be in a high impedance state.

5. Autoselect

Autoselect mode allows reading out of a binary code from the device and will identify its manufacturer and type. This mode is intended for use by programming equipment for the purpose of automatically matching the device to be programmed with its corresponding programming algorithm. This mode is functional over the entire temperature range of the device.

To activate this mode, the programming equipment must force V_{ID} (11.5 V to 12.5 V) on address pin A_9 . Two identifier bytes may then be sequenced from the device outputs by toggling address A_0 from V_{IL} to V_{IH} . All addresses are DON'T CARES except A_6 , A_1 , and A_0 (A_{-1}). (See "MBM29LV320TE/BE User Bus Operations Tables ($\overline{BYTE} = V_{IH}$ and $\overline{BYTE} = V_{IL}$)" in ■DEVICE BUS OPERATIONS.)

The manufacturer and device codes may also be read via the command register, for instances when the device is erased or programmed in a system without access to high voltage on the A_9 pin. The command sequence is illustrated in "MBM29LV320TE/BE Command Definitions Table" (■DEVICE BUS OPERATIONS) (See "2. Autoselect Command" in ■COMAND DIFINITIONS).

Word 0 ($A_0 = V_{IL}$) represents the manufacturer's code (Fujitsu = 04h) and word 1 ($A_0 = V_{IH}$) represents the device identifier code. Word 3 ($A_1 = A_0 = V_{IH}$) represents the extended device code. These three bytes/words are given in "MBM29LV320TE/BE Sector Group Protection Verify Autoselect Codes Table" and "Extended Autoselect Code Table" (■DEVICE BUS OPERATIONS). In order to read the proper device codes when executing the autoselect, A_1 must be V_{IL} . (See "MBM29LV320TE/BE Sector Group Protection Verify Autoselect Codes Table" and "Extended Autoselect Code Table" in ■DEVICE BUS OPERATIONS.)

6. Write

The device erasure and programming are accomplished via the command register. The contents of the register serve as inputs to the internal state machine. The state machine outputs dictate the device function.

The command register itself does not occupy any addressable memory location. The register is a latch used to store the commands, along with the address and data information needed to execute the command. The command register is written by bringing \overline{WE} to V_{IL} , while \overline{CE} is at V_{IL} and \overline{OE} is at V_{IH} . Addresses are latched on the falling edge of \overline{WE} or \overline{CE} , whichever starts later; while data is latched on the rising edge of \overline{WE} or \overline{CE} , whichever starts first. Standard microprocessor write timings are used.

See "Read Only Operation Characteristics" in ■AC CHARACTERISTICS for specific timing parameters.

7. Sector Group Protection

The device features hardware sector group protection. This feature disables both program and erase operations in any combination of twenty five sector groups of memory. See "Sector Group Address Tables (MBM29LV320TE/BE)" in ■FLEXIBLE SECTOR-ERASE ARCHITECTURE. The sector group protection feature is enabled using programming equipment at the user's site. The device is shipped with all sector groups unprotected.

To activate it, the programming equipment must force V_{ID} on address pin A_9 and control pin \overline{OE} , (suggest $V_{ID} = 11.5\text{ V}$), $\overline{CE} = V_{IL}$ and $A_6 = A_0 = V_{IL}$, $A_1 = V_{IH}$. The sector group addresses (A_{20} , A_{19} , A_{18} , A_{17} , A_{16} , A_{15} , A_{14} , A_{13} , and A_{12}) should be set to the sector to be protected. "Sector Address Tables (MBM29LV320TE/BE)" in ■FLEXIBLE SECTOR-ERASE ARCHITECTURE define the sector address for each of the seventy one (71) individual sectors, and "Sector Group Address Tables (MBM29LV320TE/BE)" in ■FLEXIBLE SECTOR-ERASE ARCHITECTURE define the sector group address for each of the twenty five (25) individual group sectors. Programming of the protection circuitry begins on the falling edge of the \overline{WE} pulse and is terminated with the rising edge of the same. Sector group addresses must be held constant during the \overline{WE} pulse. See "14. Sector Group Protection Timing Diagram" in ■TIMING DIAGRAM and "5. Sector Group Protection Algorithm" in ■FLOW CHART for sector group protection waveforms and algorithm.

To verify programming of the protection circuitry, the programming equipment must force V_{ID} on address pin A_9 with \overline{CE} and \overline{OE} at V_{IL} and \overline{WE} at V_{IH} . Scanning the sector group addresses (A_{20} , A_{19} , A_{18} , A_{17} , A_{16} , A_{15} , A_{14} , A_{13} , and A_{12}) while $(A_6, A_1, A_0) = (0, 1, 0)$ produces a logic "1" code at device output DQ_0 for a protected sector. Otherwise the device produces "0" for unprotected sector. In this mode, the lower order addresses, except for A_0 , A_1 , and A_6 are DON'T CARES. Address locations with $A_1 = V_{IL}$ are reserved for Autoselect manufacturer and device codes. A_{-1} requires to apply V_{IL} on byte mode.

It is also possible to determine if a sector group is protected in the system by writing an Autoselect command. Performing a read operation at the address location XX02h, where the higher order addresses (A_{20} , A_{19} , A_{18} , A_{17} , A_{16} , A_{15} , A_{14} , A_{13} , and A_{12}) are the desired sector group address will produce a logical "1" at DQ_0 for a protected sector group. See "MBM29LV320TE/BE Sector Group Protection Verify Autoselect Codes Table" and "Extended Autoselect Code Table" in ■DEVICE BUS OPERATIONS for Autoselect codes.

8. Temporary Sector Group Unprotection

This feature allows temporary unprotection of previously protected sector groups of the device in order to change data. The Sector Group Unprotection mode is activated by setting the \overline{RESET} pin to high voltage (V_{ID}). During this mode, formerly protected sector groups can be programmed or erased by selecting the sector group addresses. Once the V_{ID} is taken away from the \overline{RESET} pin, all the previously protected sector groups will be protected again. See "15. Temporary Sector Group Unprotection Timing Diagram" in ■TIMING DIAGRAM and "6. Temporary Sector Group Unprotection Algorithm" in ■FLOW CHART.

9. Extended Sector Group Protection

In addition to normal sector group protection, the device has Extended Sector Group Protection as extended function. This function enables to protect sector group by forcing V_{ID} on \overline{RESET} pin and write a command sequence. Unlike conventional procedure, it is not necessary to force V_{ID} and control timing for control pins. The extended sector group protection requires V_{ID} on \overline{RESET} pin only. With this condition, the operation is initiated by writing the set-up command (60h) into the command register. Then, the sector group addresses pins (A_{20} , A_{19} , A_{18} , A_{17} , A_{16} , A_{15} , A_{14} , A_{13} and A_{12}) and (A_6 , A_1 , A_0) = (0, 1, 0) should be set to the sector group to be protected (recommend to set V_{IL} for the other addresses pins), and write extended sector group protection command (60h). A sector group is typically protected in 250 μ s. To verify programming of the protection circuitry, the sector group addresses pins (A_{20} , A_{19} , A_{18} , A_{17} , A_{16} , A_{15} , A_{14} , A_{13} and A_{12}) and (A_6 , A_1 , A_0) = (0, 1, 0) should be set and write a command (40h). Following the command write, a logic "1" at device output DQ_0 will produce for protected sector in the read operation. If the output is logic "0", please repeat to write extended sector group protection command (60h) again. To terminate the operation, it is necessary to set \overline{RESET} pin to V_{IH} . (See "16. Extended Sector Group Protection Timing Diagram" in ■TIMING DIAGRAM and "7. Extended Sector Group Protection Algorithm" in ■FLOW CHART.)

10. \overline{RESET}

Hardware Reset

The device resets by driving \overline{RESET} pin to V_{IL} . The \overline{RESET} pin has pulse requirement and has to be kept low (V_{IL}) for at least " t_{RP} " in order to properly reset internal state machine. Any operation in the process of being executed is terminated and the internal state machine is reset to the read mode " t_{READY} " after the \overline{RESET} pin is driven low. Furthermore once the \overline{RESET} pin goes high, the device requires an additional " t_{RH} " before it allows read access. When the \overline{RESET} pin is low, the device is in the standby mode for the duration of the pulse and all the data output pins are tri-stated. If a hardware reset occurs during program or erase operation, the data at that particular location will be corrupted. Please note that the RY/BY output signal should be ignored during the \overline{RESET} pulse. See "10. \overline{RESET} , RY/BY Timing Diagram" in ■TIMING DIAGRAM for the timing diagram. See "8. Temporary Sector Group Unprotection" for additional functionality.

11. Boot Block Sector Protection

The Write Protection function provides hardware method of protecting certain boot sectors without using V_{ID} . This function is provided by the \overline{WP}/ACC pin.

If the system asserts V_{IL} on the \overline{WP}/ACC pin, the device disables program and erase functions in the two "outermost" 8 K byte boot sectors (MBM29LV320TE : SA69 and SA70, MBM29LV320BE : SA0 and SA1) independently of whether those sectors are protected or unprotected using the method described in "Sector Group Protection". The two outermost 8 K byte boot sectors are the two sectors containing the lowest addresses in a bottom-boot-configured device, or the two sectors containing the highest addresses in a top-boot-configured device.

If the system asserts V_{IH} on the \overline{WP}/ACC pin, the device reverts to whether the two outermost 8 K byte boot sectors were last set to be protected or unprotected. That is, sector group protection or unprotection for these two sectors depends on whether they were last protected or unprotected using the method described in "Sector Group Protection".

12. Accelerated Program Operation

The device offers accelerated program operation which enables the programming in high speed. If the system asserts V_{ACC} to the \overline{WP}/ACC pin, the device automatically enters the acceleration mode and the time required for program operation will reduce to about 60%. This function is primarily intended to allow high speed program, so caution is needed as the sector group becomes temporarily unprotected.

The system uses fast program command sequence when programming during acceleration mode. Set command to fast mode and reset command from fast mode are not necessary. When the device enters the acceleration mode, the device automatically set to fast mode. Therefore the present sequence is used for programming and detection of completion during acceleration mode.

Removing V_{ACC} from the \overline{WP}/ACC pin returns the device to normal operation. Do not remove V_{ACC} from \overline{WP}/ACC pin while programming. See "17. Accelerated Program Timing Diagram" in ■TIMING DIAGRAM.

Erase operation during Accelerated Program Operation is strictly prohibited.

■ COMMAND DEFINITIONS

The device operations are selected by writing specific address and data sequences into the command register. Writing incorrect address and data values or writing them in the improper sequence will reset the device to the read mode. “MBM29LV320TE/BE Command Definitions Table” in ■DEVICE BUS OPERATIONS defines the valid register command sequences. Note that the Erase Suspend (B0h) and Erase Resume (30h) commands are valid only while the Sector Erase operation is in progress. Moreover both Read/Reset commands are functionally equivalent, resetting the device to the read mode. Please note that commands are always written at DQ₇ to DQ₀ and DQ₁₅ to DQ₈ bits are ignored.

1. Read/Reset Command

In order to return from Autoselect mode or Exceeded Timing Limits (DQ₅ = 1) to Read/Reset mode, the Read/Reset operation is initiated by writing the Read/Reset command sequence into the command register. Microprocessor read cycles retrieve array data from the memory. The device remain enabled for reads until the command register contents are altered.

The device automatically powers up in the Read/Reset state. In this case, a command sequence is not required to read data. Standard microprocessor read cycles retrieves array data. This default value ensures that no spurious alteration of the memory content occurs during the power transition. See “■AC CHARACTERISTICS” for the specific timing parameters.

2. Autoselect Command

Flash memories are intended for use in applications where the local CPU alters memory contents. As such, manufacture and device codes must be accessible while the device resides in the target system. PROM programmers typically access the signature codes by raising A₉ to a high voltage. However multiplexing high voltage onto the address lines is not generally desired system design practice.

The device contains Autoselect command operation to supplement traditional PROM programming methodology. The operation is initiated by writing the Autoselect command sequence into the command register.

Following the command write, a read cycle from address (XX) 00h retrieves the manufacture code of 04h. A read cycle from address (XX) 01h for ×16 ((XX) 02h for ×8) returns the device code. A read cycle from address (XX) 03h for ×16 ((XX) 06h for ×8) returns the extended device code. (See “MBM29LV320TE/BE Sector Group Protection Verify Autoselect Codes Table” and “Extended Autoselect Code Table” in ■DEVICE BUS OPERATIONS.)

The sector state (protection or unprotection) is informed by address (XX) 02h for ×16 ((XX) 04h for ×8). Scanning the sector group addresses (A₂₀, A₁₉, A₁₈, A₁₇, A₁₆, A₁₅, A₁₄, A₁₃, and A₁₂) while (A₆, A₁, A₀) = (0, 1, 0) will produce a logic “1” at device output DQ₀ for a protected sector group. The programming verification should be performed by verify sector group protection on the protected sector. (See “MBM29LV320TE/BE User Bus Operations Tables (BYTE = V_{IH} and BYTE = V_{IL})” in ■DEVICE BUS OPERATIONS.)

To terminate the operation, it is necessary to write the Read/Reset command sequence into the register. To execute the Autoselect command during the operation, writing Read/Reset command sequence must precede the Autoselect command.

3. Byte/Word Programming

The device is programmed on a byte-by-byte (or word-by-word) basis. Programming is a four bus cycle operation. There are two “unlock” write cycles. These are followed by the program set-up command and data write cycles. Addresses are latched on the falling edge of \overline{CE} or \overline{WE} , whichever happens later and the data is latched on the rising edge of \overline{CE} or \overline{WE} , whichever happens first. The rising edge of \overline{CE} or \overline{WE} (whichever happens first) begins programming. Upon executing the Embedded Program Algorithm command sequence, the system is not required to provide further controls or timings. The device automatically provides adequate internally generated program pulses and verify programmed cell margin.

The system can determine the status of the program operation by using DQ₇ (\overline{Data} Polling), DQ₆ (Toggle Bit), or RY/ \overline{BY} . The \overline{Data} Polling and Toggle Bit must be performed at the memory location being programmed.

The automatic programming operation is completed when the data on DQ₇ is equivalent to data written to this bit at which the device return to the read mode and addresses are no longer latched. See “Hardware Sequence Flags Table”. Therefore the device requires that a valid address to the device be supplied by the system at this particular instance of time. Hence Data Polling must be performed at the memory location being programmed.

Any commands written to the chip during this period will be ignored. If hardware reset occurs during the programming operation, it is impossible to guarantee the data are being written.

Programming is allowed in any sequence and across sector boundaries. Beware that a data “0” cannot be programmed back to a “1”. Attempting to do so may either hang up the device or result in an apparent success according to the data polling algorithm but a read from Read/Reset mode will show that the data is still “0”. Only erase operations can convert “0”s to “1”s.

“1. Embedded Program™ Algorithm” in ■FLOW CHART illustrates the Embedded Program™ Algorithm using typical command strings and bus operations.

4. Chip Erase

Chip erase is a six bus cycle operation. There are two “unlock” write cycles. These are followed by writing the “set-up” command. Two more “unlock” write cycles are then followed by the chip erase command.

Chip erase does not require the user to program prior to erase. Upon executing the Embedded Erase Algorithm command sequence the device automatically programs and verifies the entire memory for an all zero data pattern prior to electrical erase (Preprogram function). The system is not required to provide any controls or timings during these operations.

The system can determine the erase operation status by using DQ₇ ($\overline{\text{Data Polling}}$), DQ₆ (Toggle Bit), or RY/ $\overline{\text{BY}}$. The chip erase begins on the rising edge of the last $\overline{\text{CE}}$ or $\overline{\text{WE}}$, whichever happens first in the command sequence and terminates when the data on DQ₇ is “1” (See “12. Write Operation Status”.) at which time the device returns to read the mode.

Chip Erase Time; Sector Erase Time × All sectors + Chip Program Time (Preprogramming)

“2. Embedded Erase™ Algorithm” in ■FLOW CHART illustrates the Embedded Erase™ Algorithm using typical command strings and bus operations.

5. Sector Erase

Sector erase is a six bus cycle operation. There are two “unlock” write cycles. These are followed by writing the “set-up” command. Two more “unlock” write cycles are then followed by the Sector Erase command. The sector address (any address location within the desired sector) is latched on the falling edge of $\overline{\text{CE}}$ or $\overline{\text{WE}}$ whichever starts later, while the command (Data = 30h) is latched on the rising edge of $\overline{\text{CE}}$ or $\overline{\text{WE}}$ which happens first. After time-out of “t_{row}” from the rising edge of the last sector erase command, the sector erase operation will begin.

Multiple sectors are erased concurrently by writing the six bus cycle operations on “MBM29LV320TE/BE Command Definitions Table” in ■DEVICE BUS OPERATIONS. This sequence is followed with writes of the Sector Erase command to addresses in other sectors desired to be concurrently erased. The time between writes must be less than “t_{row}” otherwise that command will not be accepted and erasure will not start. It is recommended that processor interrupts be disabled during this time to guarantee this condition. The interrupts can be re-enabled after the last Sector Erase command is written. A time-out of “t_{row}” from the rising edge of last $\overline{\text{CE}}$ or $\overline{\text{WE}}$ whichever starts first initiates the execution of the Sector Erase command(s). If another falling edge of $\overline{\text{CE}}$ or $\overline{\text{WE}}$, whichever starts first occurs within the “t_{row}” time-out window the timer is reset. (Monitor DQ₃ to determine if the sector erase timer window is still open, see “16. DQ₃”, Sector Erase Timer.) Any command other than Sector Erase or Erase Suspend during this time-out period will reset the device to the read mode, ignoring the previous command string. Resetting the device once execution has begun will corrupt the data in the sector. In that case, restart the erase on those sectors and allow them to complete. (See “12. Write Operation Status” for Sector Erase Timer operation.) Loading the sector erase buffer may be done in any sequence and with any number of sectors (0 to 70).

Sector erase does not require the user to program the device prior to erase. The device automatically program all memory locations in the sector (s) to be erased prior to electrical erase (Preprogram function). When erasing

a sector or sectors the remaining unselected sectors are not affected. The system is not required to provide any controls or timings during these operations.

The system can determine the status of the erase operation by using DQ_7 ($\overline{\text{Data}}$ Polling), DQ_6 (Toggle Bit), or $RY/\overline{\text{BY}}$.

The sector erase begins after the “ t_{row} ” time out from the rising edge of $\overline{\text{CE}}$ or $\overline{\text{WE}}$ whichever starts first for the last sector erase command pulse and terminates when the data on DQ_7 is “1” (See “12. Write Operation Status”). at which the device return to the read mode. $\overline{\text{Data}}$ polling and Toggle Bit must be performed at an address within any of the sectors being erased.

Multiple Sector Erase Time; [Sector Erase Time + Sector Program Time (Preprogramming)] × Number of Sector Erase

“2. Embedded Erase™ Algorithm” in ■FLOW CHART illustrates the Embedded Erase™ Algorithm using typical command strings and bus operations.

6. Erase Suspend/Resume

The Erase Suspend command allows the user to interrupt a Sector Erase operation and then perform data reads from or programs to a sector not being erased. This command is applicable ONLY during the Sector Erase operation which includes the time-out period for sector erase. The Erase Suspend command will be ignored if written during the Chip Erase operation or Embedded Program Algorithm. Writing the Erase Suspend command (B0h) during the Sector Erase time-out results in immediate termination of the time-out period and suspension of the erase operation.

Writing the Erase Resume command (30h) resumes the erase operation. The addresses are “DON'T CARES” when writing the Erase Suspend or Erase Resume command.

When the Erase Suspend command is written during the Sector Erase operation, the device will take a maximum of “ t_{SPD} ” to suspend the erase operation. When the device has entered the erase-suspended mode, the $RY/\overline{\text{BY}}$ output pin is at high impedance state and the DQ_7 bit is at logic “1”, and DQ_6 stops toggling. The user must use the address of the erasing sector for reading DQ_6 and DQ_7 to determine if the erase operation is suspended. Further writes of the Erase Suspend command are ignored.

When the erase operation is suspended, the device defaults to the erase-suspend-read mode. Reading data in this mode is the same as reading from the standard read mode except that the data must be read from sectors that have not been erase-suspended. Successively reading from the erase-suspended sector while the device is in the erase-suspend-read mode will cause DQ_2 to toggle. See “17. DQ_2 ”.

After entering the erase-suspend-read mode, the users can program the device by writing the appropriate command sequence for Program. This program mode is known as the erase-suspend-program mode. Again, programming in this mode is the same as programming in the regular Program mode except that the data must be programmed to sectors that are not erase-suspended. Successively reading from the erase-suspended sector while the device is in the erase-suspend-program mode causes DQ_2 to toggle. The end of the erase-suspended Program operation is detected by the $RY/\overline{\text{BY}}$ output pin, $\overline{\text{Data}}$ polling of DQ_7 or by the Toggle Bit I (DQ_6) which is the same as the regular Program operation. Note that DQ_7 must be read from the Program address while DQ_6 can be read from any address.

To resume the operation of Sector Erase, the Resume command (30h) should be written. Any further writes of the Resume command at this point is ignored. Another Erase Suspend command is written after the chip resumes erasing.

7. Extended Command

(1) Fast Mode

Fast Mode function. This mode dispenses with the initial two unlock cycles required in the standard program command sequence by writing Fast Mode command into the command register. In this mode the required bus cycle for programming is two cycles instead of four bus cycles in standard program command. The read operation is also executed after exiting this mode. During the Fast mode, do not write any command other than the Fast program/Fast mode reset command. To exit this mode, it is necessary to write Fast Mode Reset command into the command register. (See “8. Embedded Program™ Algorithm for Fast Mode” in ■FLOW CHART.) The V_{CC} active current is required even $\overline{\text{CE}} = V_{\text{IH}}$ during Fast Mode.

(2) Fast Programming

During Fast Mode, the programming can be executed with two bus cycles operation. The Embedded Program Algorithm is executed by writing program set-up command (A0h) and data write cycles (PA/PD). (See “8. Embedded Program™ Algorithm for Fast Mode” in ■FLOW CHART.)

(3) CFI (Common Flash Memory Interface)

The CFI (Common Flash Memory Interface) specification outlines device and host system software interrogation handshake which allows specific vendor-specified software algorithms to be used for entire families of device. This allows device-independent, JEDEC ID-independent, and forward-and backward-compatible software support for the specified flash device families. See “Common Flash Memory Interface Code Table” in ■FLEXIBLE SECTOR-ERASE ARCHITECTURE for details.

The operation is initiated by writing the query command (98h) into the command register. Following the command write, a read cycle from specific address retrieves device information. Please note that output data of upper byte (DQ₁₅ to DQ₈) is “0” in word mode (16 bit) read. See “Common Flash Memory Interface Code Table” in ■FLEXIBLE SECTOR-ERASE ARCHITECTURE. To terminate operation, it is necessary to write the read/reset command sequence into the register. (See “Common Flash Memory Interface Code Table” in ■FLEXIBLE SECTOR-ERASE ARCHITECTURE.)

8. HiddenROM Region

The HiddenROM feature provides a Flash memory region that the system may access through a new command sequence. This is primarily intended for customers who wish to use an Electronic Serial Number (ESN) in the device with the ESN protected against modification. Once the HiddenROM region is protected, any further modification of that region is impossible. This ensures the security of the ESN once the product is shipped to the field.

The HiddenROM region is 256 bytes in length and is stored at the same address of the “outermost” 8 K byte boot sector. The MBM29LV320TE occupies the address of the byte mode 3FFFC0h to 3FFFFFFh (word mode 1FFFE0h to 1FFFFFFh) and the MBM29LV320BE type occupies the address of the byte mode 000000h to 000080h (word mode 000000h to 000040h) . After the system writes Enter HiddenROM command sequence, the system can read the HiddenROM region by using the addresses normally occupied by the boot sector. That is, the device sends all commands that would normally be sent to the boot sector to the HiddenROM region. This mode of operation continues until the system issues the Exit HiddenROM command sequence, or until power is removed from the device. On power-up, or following a hardware reset, the device reverts to sending commands to the boot sector.

9. HiddenROM Entry Command

The device has a HiddenROM area with One Time Protect function. This area is to enter the security code and to enable the change of the code once set. Program/erase is possible in this area until it is protected. However once it is protected, it is impossible to unprotect so please use this with caution.

HiddenROM area is 256 byte and in the same address area of “outermost” 8 K byte boot block. Therefore, write the HiddenROM entry command sequence to enter the HiddenROM area. It is called as HiddenROM mode when the HiddenROM area appears.

Sector other than the boot block area could be read during HiddenROM mode. Read/Program of the HiddenROM area is possible during HiddenROM mode. Write the HiddenROM reset command sequence to exit the HiddenROM mode.

10. HiddenROM Program Command

To program the data to the HiddenROM area, write the HiddenROM program command sequence during HiddenROM mode. This command is the same as the program command in usual except to write the command during HiddenROM mode. Therefore the detection of completion method is the same as, using the DQ₇ data polling, DQ₆ toggle bit and RY/ $\overline{\text{BY}}$ pin. Need to pay attention to the address to be programmed. If the address other than the HiddenROM area is selected to program, data of the address will be changed.

Please note that the sector erase command is prohibited during HiddenROM mode. If the sector erase command is appeared in this mode, data of the address will be erased.

11. HiddenROM Protect Command

There are two methods to protect the HiddenROM area. One of them is to write the sector group protect setup command (60h) , set the sector address in the HiddenROM area and $(A_6, A_1, A_0) = (0,1,0)$, and write the sector group protect command (60h) during the HiddenROM mode. The same command sequence could be used because it is the same with the extension sector group protect except that it is in the HiddenROM mode and it does not apply high voltage to \overline{RESET} pin. Please see “9. Extended Sector Group Protection” in ■FUNCTIONAL DESCRIPTION for details of extention sector group protect setting.

The other is to apply high voltage (V_{ID}) to A_9 and \overline{OE} , set the sector address in the HiddenROM area and $(A_6, A_1, A_0) = (0,1,0)$, and apply the write pulse during the HiddenROM mode. To verify the protect circuit, apply high voltage (V_{ID}) to A_9 , specify $(A_6, A_1, A_0) = (0,1,0)$ and the sector address in the HiddenROM area, and read. When “1” appears on DQ_0 , the protect setting is completed. “0” will appear on DQ_0 if it is not protected. Please apply write pulse agian. The same command sequence could be used for the above method because other than the HiddenROM mode, it is the same as the sector group protect in the past. Please see “7. Sector Group Protection” in ■FUNCTIONAL DESCRIPTION for details of the sector group protect setting.

Other sector group will be effected if the address other than those for HiddenROM area is selected for the sector group address, so please be carefull. Once it is protected, protection can not be cancelled, so please pay the closest attention.

12. Write Operation Status

Details in “Hardware Sequence Flags Table” are all the status flags that can be used to check the status of the device for current mode operation. During sector erase, the part provides the status flags automatically to the I/O ports. The information on DQ_2 is address sensitive. This means that if an address from an erasing sector is consecutively read, then the DQ_2 bit will toggle. However, DQ_2 will not toggle if an address from a non-erasing sector is consecutively read. This allows users to determine which sectors are in erase.

Once erase suspend is entered, address sensitivity still applies. If the address of a non-erasing sector (that is, one available for read) is provided, then stored data can be read from the device. If the address of an erasing sector (that is, one unavailable for read) is applied, the device will output its status bits.

Hardware Sequence Flags Table

Status		\overline{DQ}_7	DQ_6	DQ_5	DQ_3	DQ_2	
In Progress	Embedded Program Algorithm	\overline{DQ}_7	Toggle	0	0	1	
	Embedded Erase Algorithm	0	Toggle	0	1	Toggle *1	
	Erase Suspended Mode	Erase Suspend Read (Erase Suspended Sector)	1	1	0	0	Toggle
		Erase Suspend Read (Non-Erase Suspended Sector)	Data	Data	Data	Data	Data
	Erase Suspend Program (Non-Erase Suspended Sector)	\overline{DQ}_7	Toggle	0	0	1 *2	
Exceeded Time Limits	Embedded Program Algorithm	\overline{DQ}_7	Toggle	1	0	1	
	Embedded Erase Algorithm	0	Toggle	1	1	N/A	
	Erase Suspended Mode	Erase Suspend Program (Non-Erase Suspended Sector)	\overline{DQ}_7	Toggle	1	0	N/A

*1: Successive reads from the erasing or erase-suspend sector cause DQ_2 to toggle.

*2: Reading from non-erase suspend sector address indicates logic “1” at the DQ_2 bit.

13. DQ₇

Data Polling

The device features $\overline{\text{Data}}$ Polling as a method to indicate to the host that the Embedded Algorithms are in progress or completed. During the Embedded Program Algorithm an attempt to read the device produces a complement of data last written to DQ₇. Upon completion of the Embedded Program Algorithm, an attempt to read device produces true data last written to DQ₇. During the Embedded Erase Algorithm, an attempt to read device produces a “0” at the DQ₇ output. Upon completion of the Embedded Erase Algorithm an attempt to read device produces a “1” on DQ₇. The flowchart for $\overline{\text{Data}}$ Polling (DQ₇) is shown in “3. $\overline{\text{Data}}$ Polling Algorithm” (■FLOW CHART).

For programming, the $\overline{\text{Data}}$ Polling is valid after the rising edge of the fourth write pulse in the four write pulse sequence.

For chip erase and sector erase, the $\overline{\text{Data}}$ Polling is valid after the rising edge of the sixth write pulse in the six write pulse sequence. $\overline{\text{Data}}$ Polling must be performed at sector address within any of the sectors being erased, not a protected sectors. Otherwise, the status may be invalid.

Once the Embedded Algorithm operation is close to being completed, the device data pins (DQ₇) may change asynchronously while the output enable ($\overline{\text{OE}}$) is asserted low. This means that the device is driving status information on DQ₇ at one instant of time and then that byte's valid data the next instant of time. Depending on when the system samples the DQ₇ output, it may read the status or valid data. Even if the device has completed the Embedded Algorithm operation and DQ₇ has a valid data, the data outputs on DQ₀ to DQ₆ may be still invalid. The valid data on DQ₀ to DQ₇ will be read on the successive read attempts.

The $\overline{\text{Data}}$ Polling feature is only active during the Embedded Programming Algorithm, Embedded Erase Algorithm, Erase Suspend mode or sector erase time-out. (See “Hardware Sequence Flags” Table.)

See “6. $\overline{\text{Data}}$ Polling during Embedded Algorithm Operation Timing Diagram” in ■TIMING DIAGRAM for the $\overline{\text{Data}}$ Polling timing specifications and diagrams.

14. DQ₆

Toggle Bit I

The device also features the “Toggle Bit I” as a method to indicate to the host system that the Embedded Algorithms are in progress or completed.

During Embedded Program or Erase Algorithm cycle, successive attempts to read ($\overline{\text{CE}}$ or $\overline{\text{OE}}$ toggling) data from the device results in DQ₆ toggling between one and zero. Once the Embedded Program or Erase Algorithm cycle is completed, DQ₆ stops toggling and valid data is read on the next successive attempts. During programming, the Toggle Bit I is valid after the rising edge of the fourth write pulse in the four write pulse sequence. For chip erase and sector erase, the Toggle Bit I is valid after the rising edge of the sixth write pulse in the six write pulse sequence. The Toggle Bit I is active during the sector time out.

In program operation, if the sector being written to be protected, the toggle bit toggles for about 1 μs and then stops toggling with data unchanged. In erase operation, the device erases all selected sectors except for ones that are protected. If all selected sectors are protected, chip toggles the toggle bit for about 400 μs and then drop back into read mode, having data unchanged.

Either $\overline{\text{CE}}$ or $\overline{\text{OE}}$ toggling causes DQ₆ to toggle.

See “7. Toggle Bit I during Embedded Algorithm Operation Timing Diagram” in ■TIMING DIAGRAM for the Toggle Bit I timing specifications and diagrams.

15. DQ₅

Exceeded Timing Limits

DQ₅ indicates if the program or erase time has exceeded the specified limits (internal pulse count) . Under these conditions DQ₅ produces a “1”. This is a failure condition which indicates that the program or erase cycle was not successfully completed. $\overline{\text{Data}}$ Polling is the only operating function of device under this condition. The $\overline{\text{CE}}$ circuit partially powers down device under these conditions (to approximately 2 mA) . The $\overline{\text{OE}}$ and $\overline{\text{WE}}$ pins

control the output disable functions as described in “MBM29LV320TE/BE User Bus Operations Tables ($\overline{\text{BYTE}} = V_{IH}$ and $\overline{\text{BYTE}} = V_{IL}$)” (■DEVICE BUS OPERATIONS).

The DQ₅ failure condition may also appear if a user tries to program a non blank location without erasing. In this case the device locks out and never complete the Embedded Algorithm operation. Hence, the system never read valid data on DQ₇ bit and DQ₆ never stop toggling. Once the device has exceeded timing limits, the DQ₅ bit indicates a “1.” Please note that this is not a device failure condition since device was incorrectly used. If this occurs, reset device with command sequence.

16. DQ₃

Sector Erase Timer

After completion of the initial sector erase command sequence the sector erase time-out will begin. DQ₃ remains low until the time-out is completed. $\overline{\text{Data}}$ Polling and Toggle Bit are valid after the initial sector erase command sequence.

If $\overline{\text{Data}}$ Polling or Toggle Bit I indicates device has been written with a valid erase command, DQ₃ may be used to determine if the sector erase timer window is still open. If DQ₃ is high (“1”) the internally controlled erase cycle has begun; attempts to write subsequent commands to the device be ignored until the erase operation is completed as indicated by $\overline{\text{Data}}$ Polling or Toggle Bit I. If DQ₃ is low (“0”), the device will accept additional sector erase commands. To insure the command has been accepted, the system software should check the status of DQ₃ prior to and following each subsequent Sector Erase command. If DQ₃ were high on the second status check, the command may not have been accepted.

See “Hardware Sequence Flags Table”.

17. DQ₂

Toggle Bit II

This toggle bit II, along with DQ₆, can be used to determine whether the device is in the Embedded Erase Algorithm or in Erase Suspend.

Successive reads from the erasing sector cause DQ₂ to toggle during the Embedded Erase Algorithm. If the device is in the erase-suspended-read mode, successive reads from the erase-suspended sector causes DQ₂ to toggle. When the device is in the erase-suspended-program mode, successive reads from the byte address of the non-erase suspended sector indicate a logic “1” at the DQ₂ bit.

DQ₆ is different from DQ₂ in that DQ₆ toggles only when the standard program or erase, or erase suspend program operation is in progress. The behavior of these two status bits, along with that of DQ₇, is summarized as follows :

For example, DQ₂ and DQ₆ are used together to determine if the erase-suspend-read mode is in progress. (DQ₂ toggles while DQ₆ does not.) See also “Toggle Bit Status Table” and “8. DQ₂ vs DQ₆” in ■TIMING DIAGRAM.

Furthermore, DQ₂ is used to determine which sector is being erased. When the device is in the erase mode, DQ₂ toggles if this bit is read from an erasing sector.

18. Reading Toggle Bits DQ₆/DQ₂

Whenever the system initially begins reading toggle bit status, it must read DQ₇ to DQ₀ at least twice in a row to determine whether a toggle bit is toggling. Typically, a system would note and store the value of the toggle bit after the first read. After the second read, the system would compare the new value of the toggle bit with the first read. If the toggle bit is not toggling, indicates that the device has completed the program or erase operation. The system can read array data on DQ₇ to DQ₀ on the following read cycle.

However if after the initial two read cycles, the system determines that the toggle bit is still toggling, the system also should note whether the value of DQ₅ is high (see “15. DQ₅”) . If it is the system should then determine again whether the toggle bit is toggling, since the toggle bit may have stopped toggling just as DQ₅ went high. If the toggle bit is no longer toggling, the device has successfully completed the program or erase operation. If it is still toggling, the device did not complete the operation successfully, and the system must write the reset command to return to reading array data.

The remaining scenario is that the system initially determines that the toggle bit is toggling and DQ₅ has not gone high. The system may continue to monitor the toggle bit and DQ₅ through successive read cycles, deter-

mining the status as described in the previous paragraph. Alternatively, the system may choose to perform other system tasks. In this case, the system must start at the beginning of the algorithm when it returns to determine the status of the operation. See “4. Toggle Bit Algorithm” in ■FLOW CHART.

Toggle Bit Status Table

Mode	DQ ₇	DQ ₆	DQ ₂
Program	$\overline{DQ_7}$	Toggle	1
Erase	0	Toggle	Toggle* ¹
Erase-Suspend Read (Erase-Suspended Sector)	1	1	Toggle
Erase-Suspend Program	$\overline{DQ_7}$	Toggle	1* ²

*1 : Successive reads from the erasing or erase-suspend sector cause DQ₂ to toggle.

*2 : Reading from non-erase suspend sector address indicates logic “1” at the DQ₂ bit.

19. RY/ \overline{BY}

Ready/Busy

The device provides a RY/ \overline{BY} open-drain output pin as a way to indicate to the host system that the Embedded Algorithms are either in progress or has been completed. If output is low, the device is busy with either a program or erase operation. If output is high, the device is ready to accept any read/write or erase operation. When the RY/ \overline{BY} pin is low, the device will not accept any additional program or erase commands. If the device is placed in an Erase Suspend mode, RY/ \overline{BY} output is high.

During programming, RY/ \overline{BY} pin is driven low after the rising edge of the fourth write pulse. During an erase operation, RY/ \overline{BY} pin is driven low after the rising edge of the sixth write pulse. RY/ \overline{BY} pin indicates a busy condition during \overline{RESET} pulse. See “9. RY/ \overline{BY} Timing Diagram during Program/Erase operations” and “10. \overline{RESET} , RY/ \overline{BY} Timing Diagram” in ■TIMING DIAGRAM for a detailed timing diagram. RY/ \overline{BY} pin is pulled high in standby mode.

Since this is an open-drain output, the pull-up resistor needs to be connected to V_{CC}; multiples of devices may be connected to the host system via more than one RY/ \overline{BY} pin in parallel.

20. Byte/Word Configuration

\overline{BYTE} pin selects byte (8-bit) mode or word (16-bit) mode for device. When this pin is driven high, the device operates in word (16-bit) mode. Data is read and programmed at DQ₁₅ to DQ₀. When this pin is driven low, the device operates in byte (8-bit) mode. Under this mode, DQ₁₅/A₋₁ pin becomes the lowest address bit, and DQ₁₄ to DQ₈ bits are tri-stated. However, the command bus cycle is always an 8-bit operation and hence commands are written at DQ₁₅ to DQ₈ and the DQ₇ to DQ₀ bits are ignored. See “11. Word Mode Configuration Timing Diagram”, “12. Byte Mode Configuration Timing Diagram” and “13. \overline{BYTE} Timing Diagram for Write Operations” in ■TIMING DIAGRAM the detail .

21. Data Protection

The device is designed to offer protection against accidental erasure or programming caused by spurious system level signals that may exist during power transitions. During power up device automatically resets internal state machine in Read mode. Also, with its control register architecture, alteration of memory contents only occurs after successful completion of specific multi-bus cycle command sequences.

The device also incorporates several features to prevent inadvertent write cycles resulting from V_{CC} power-up and power-down transitions or system noise.

22. Low V_{CC} Write Inhibit

To avoid initiation of a write cycle during V_{CC} power-up and power-down, write cycle is locked out for V_{CC} less than V_{LKO} (Min) . If V_{CC} < V_{LKO}, the command register is disabled and all internal program/erase circuits are disabled. Under this condition the device resets to the read mode. Subsequent writes are ignored until the V_{CC} level is greater than V_{LKO}. It is the users responsibility to ensure that the control pins are logically correct to prevent unintentional writes when V_{CC} is above V_{LKO} (Min) .

If Embedded Erase Algorithm is interrupted, there is possibility that the erasing sector (s) cannot be used.

23. Write Pulse “Glitch” Protection

Noise pulses of less than 3 ns (Typ) on \overline{OE} , \overline{CE} , or \overline{WE} does not initiate write cycle.

24. Logical Inhibit

Writing is inhibited by holding any one of $\overline{OE} = V_{IL}$, $\overline{CE} = V_{IH}$, or $\overline{WE} = V_{IH}$. To initiate a write cycle \overline{CE} and \overline{WE} must be logical zero while \overline{OE} is a logical one.

25. Power-Up Write Inhibit

Power-up of the device with $\overline{WE} = \overline{CE} = V_{IL}$ and $\overline{OE} = V_{IH}$ does not accept commands on the rising edge of \overline{WE} . The internal state machine is automatically reset to the read mode on power-up.

26. Sector Group Protection

Device user is able to protect each sector group individually to store and protect data. Protection circuit voids both write and erase commands that are addressed to protected sectors.

Any commands to write or erase addressed to protected sector are ignore. (See “7. Sector Group Protection” in ■FUNCTIONAL DESCRIPTION.)

■ ABSOLUTE MAXIMUM RATINGS

Parameter	Symbol	Rating		Unit
		Min	Max	
Storage Temperature	T _{stg}	-55	+125	°C
Ambient Temperature with Power Applied	T _A	-40	+85	°C
Voltage with Respect to Ground All pins except A ₉ , $\overline{\text{OE}}$, and $\overline{\text{RESET}}$ *1, *2	V _{IN} , V _{OUT}	-0.5	V _{CC} + 0.5	V
Power Supply Voltage *1	V _{CC}	-0.5	+4.0	V
A ₉ , $\overline{\text{OE}}$, and $\overline{\text{RESET}}$ *1, *3	V _{IN}	-0.5	+13.0	V
$\overline{\text{WP/ACC}}$ *1, *4	V _{ACC}	-0.5	+13.0	V

*1 : Voltage is defined on the basis of V_{SS} = GND = 0 V.

*2 : Minimum DC voltage on input or I/O pins is -0.5 V. During voltage transitions, input or I/O pins may undershoot V_{SS} to -2.0 V for periods of up to 20 ns. Maximum DC voltage on input or I/O pins is V_{CC} + 0.5 V. During voltage transitions, input or I/O pins may overshoot to V_{CC} + 2.0 V for periods of up to 20 ns.

*3 : Minimum DC input voltage on A₉, $\overline{\text{OE}}$ and $\overline{\text{RESET}}$ pins is -0.5 V. During voltage transitions, A₉, $\overline{\text{OE}}$ and $\overline{\text{RESET}}$ pins may undershoot V_{SS} to -2.0 V for periods of up to 20 ns. Voltage difference between input and supply voltage (V_{IN} - V_{CC}) does not exceed +9.0 V. Maximum DC input voltage on A₉, $\overline{\text{OE}}$ and $\overline{\text{RESET}}$ pins is +13.0 V which may overshoot to +14.0 V for periods of up to 20 ns.

*4 : Minimum DC input voltage on $\overline{\text{WP/ACC}}$ pin is -0.5 V. During voltage transitions, $\overline{\text{WP/ACC}}$ pin may undershoot V_{SS} to -2.0 V for periods of up to 20 ns. Maximum DC input voltage on $\overline{\text{WP/ACC}}$ pin is +13.0 V which may overshoot to +12.0 V for periods of up to 20 ns when V_{CC} is applied.

WARNING: Semiconductor devices can be permanently damaged by application of stress (voltage, current, temperature, etc.) in excess of absolute maximum ratings. Do not exceed these ratings.

■ RECOMMENDED OPERATING CONDITIONS

Parameter	Symbol	Part No.	Value		Unit
			Min	Max	
Ambient Temperature	T _A	MBM29LV320TE/BE 80/90/10	-40	+85	°C
Power Supply Voltage*	V _{CC}	MBM29LV320TE/BE 80/90	+3.0	+3.6	V
		MBM29LV320TE/BE 10	+2.7	+3.6	

* : Voltage is defined on the basis of V_{SS} = GND = 0 V.

WARNING: The recommended operating conditions are required in order to ensure the normal operation of the semiconductor device. All of the device's electrical characteristics are warranted when the device is operated within these ranges.

Always use semiconductor devices within their recommended operating condition ranges. Operation outside these ranges may adversely affect reliability and could result in device failure.

No warranty is made with respect to uses, operating conditions, or combinations not represented on the data sheet. Users considering application outside the listed conditions are advised to contact their FUJITSU representatives beforehand.

■ MAXIMUM OVERSHOOT/MAXIMUM UNDERSHOOT

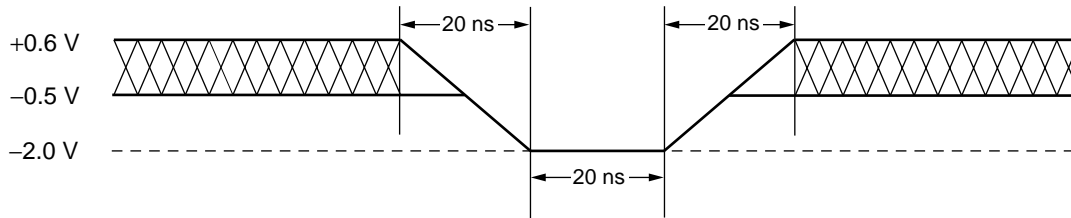

Maximum Undershoot Waveform

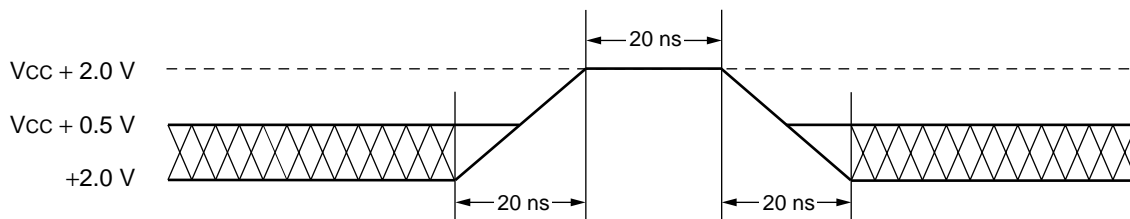

Maximum Overshoot Waveform 1

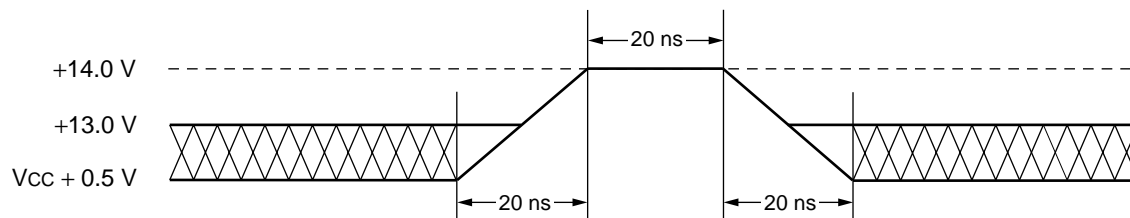

Note : This waveform is applied for A_9 , \overline{OE} , and \overline{RESET} .

Maximum Overshoot Waveform 2

■ DC CHARACTERISTICS

Parameter	Symbol	Conditions	Min	Max	Unit	
Input Leakage Current	I_{LI}	$V_{IN} = V_{SS}$ to V_{CC} , $V_{CC} = V_{CC}$ Max	-1.0	+1.0	μA	
Output Leakage Current	I_{LO}	$V_{OUT} = V_{SS}$ to V_{CC} , $V_{CC} = V_{CC}$ Max	-1.0	+1.0	μA	
A_9 , \overline{OE} , \overline{RESET} Inputs Leakage Current	I_{LIT}	$V_{CC} = V_{CC}$ Max, A_9 , \overline{OE} , $\overline{RESET} = 12.5$ V	—	35	μA	
V _{CC} Active Current *1	I_{CC1}	$\overline{CE} = V_{IL}$, $\overline{OE} = V_{IH}$, $f = 5$ MHz	Byte	—	16	mA
			Word	—	18	
		$\overline{CE} = V_{IL}$, $\overline{OE} = V_{IH}$, $f = 1$ MHz	Byte	—	7	mA
			Word	—	7	
V _{CC} Active Current *2	I_{CC2}	$\overline{CE} = V_{IL}$, $\overline{OE} = V_{IH}$	—	40	mA	
V _{CC} Current (Standby)	I_{CC3}	$V_{CC} = V_{CC}$ Max, $\overline{CE} = V_{CC} \pm 0.3$ V, $\overline{RESET} = V_{CC} \pm 0.3$ V	—	5	μA	
V _{CC} Current (Standby, Reset)	I_{CC4}	$V_{CC} = V_{CC}$ Max, $\overline{WE}/\overline{ACC} = V_{CC} \pm 0.3$ V, $\overline{RESET} = V_{SS} \pm 0.3$ V	—	5	μA	
V _{CC} Current (Automatic Sleep Mode) *3	I_{CC5}	$V_{CC} = V_{CC}$ Max, $\overline{CE} = V_{SS} \pm 0.3$ V, $\overline{RESET} = V_{CC} \pm 0.3$ V $V_{IN} = V_{CC} \pm 0.3$ V or $V_{SS} \pm 0.3$ V	—	5	μA	
$\overline{WP}/\overline{ACC}$ Accelerated Program Current	I_{ACC}	$V_{CC} = V_{CC}$ Max, $\overline{WP}/\overline{ACC} = V_{ACC}$ Max	—	20	mA	
Input Low Voltage	V_{IL}	—	-0.5	+0.6	V	
Input High Voltage	V_{IH}	—	2.0	$V_{CC} + 0.3$	V	
Voltage for $\overline{WP}/\overline{ACC}$ Sector Protection/Unprotection and Program Acceleration	V_{ACC}	—	11.5	12.5	V	
Voltage for Autoselect and Sector Group Protection (A_9 , \overline{OE} , \overline{RESET}) *4	V_{ID}	—	11.5	12.5	V	
Output Low Voltage	V_{OL}	$I_{OL} = 4.0$ mA, $V_{CC} = V_{CC}$ Min	—	0.45	V	
Output High Voltage	V_{OH1}	$I_{OH} = -2.0$ mA, $V_{CC} = V_{CC}$ Min	2.4	—	V	
	V_{OH2}	$I_{OH} = -100$ μA	$V_{CC} - 0.4$	—	V	
Low V _{CC} Lock-Out Voltage	V_{LKO}	—	2.3	2.5	V	

* 1: The I_{CC} current listed includes both the DC operating current and the frequency dependent component.

* 2: I_{CC} active while Embedded Algorithm (program or erase) is in progress.

* 3: Automatic sleep mode enables the low power mode when addresses remain stable for 150 ns.

* 4: Applicable for only V_{CC} applying.

MBM29LV320TE/BE80/90/10

AC CHARACTERISTICS

Read Only Operations Characteristics

Parameter	Symbol		Condition	Value						Unit
	JEDEC	Standard		80*		90*		10*		
				Min	Max	Min	Max	Min	Max	
Read Cycle Time	t _{AVAV}	t _{RC}	—	80	—	90	—	100	—	ns
Address to Output Delay	t _{AVQV}	t _{ACC}	$\overline{CE} = V_{IL}$ $\overline{OE} = V_{IL}$	—	80	—	90	—	100	ns
Chip Enable to Output Delay	t _{ELQV}	t _{CE}	$\overline{OE} = V_{IL}$	—	80	—	90	—	100	ns
Output Enable to Output Delay	t _{GLQV}	t _{OE}	—	—	30	—	35	—	35	ns
Chip Enable to Output High-Z	t _{EHQZ}	t _{DF}	—	—	25	—	30	—	30	ns
Output Enable to Output High-Z	t _{GHQZ}	t _{DF}	—	—	25	—	30	—	30	ns
Output Hold Time From Addresses, \overline{CE} or \overline{OE} , Whichever Occurs First	t _{AXQX}	t _{OH}	—	0	—	0	—	0	—	ns
\overline{RESET} Pin Low to Read Mode	—	t _{READY}	—	—	20	—	20	—	20	μs
\overline{CE} to \overline{BYTE} Switching Low or High	—	t _{ELFL} t _{ELFH}	—	—	5	—	5	—	5	ns

* : Test Conditions :

Output Load : 1 TTL gate and 30 pF (MBM29LV320TE80, MBM29LV320BE80)
100 pF (MBM29LV320TE90/10, MBM29LV320BE90/10)

Input rise and fall times : 5 ns

Input pulse levels : 0.0 V or 3.0 V

Timing measurement reference level

Input : 1.5 V

Output : 1.5 V

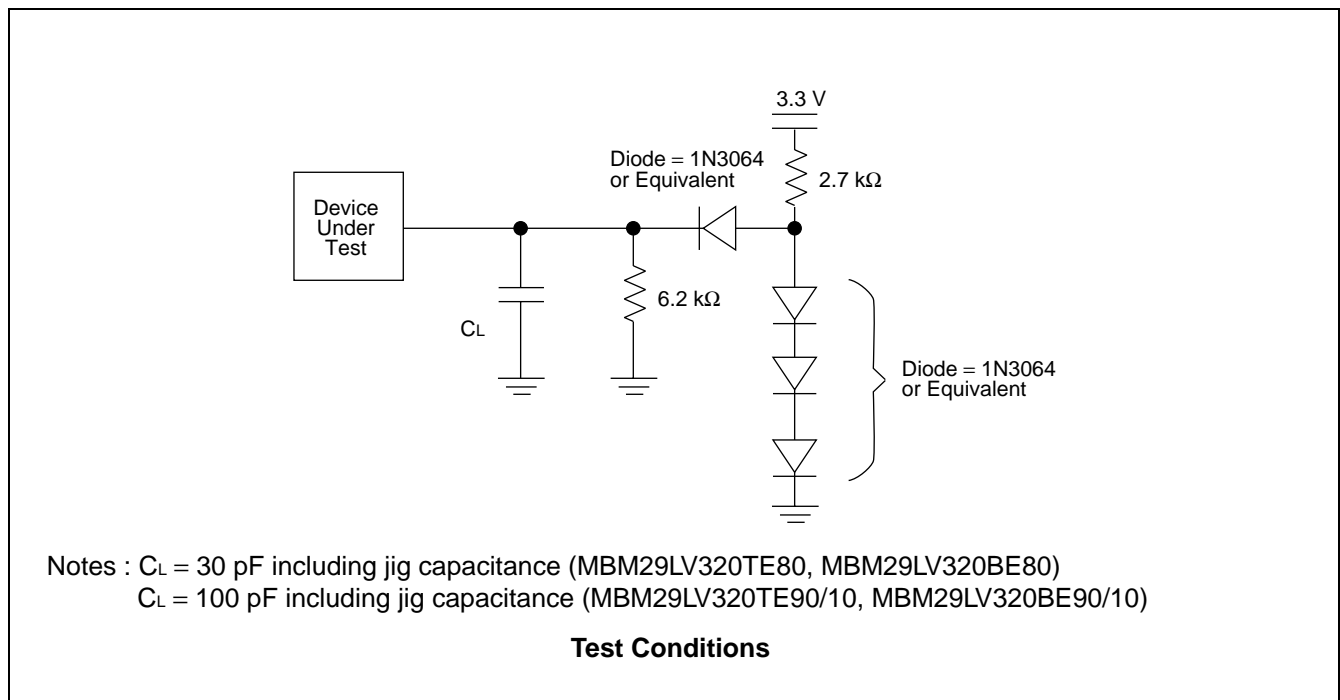

• Write/Erase/Program Operations

Parameter		Symbol		Value									Unit
		JEDEC	Standard	80 (Note)			90 (Note)			10 (Note)			
				Min	Typ	Max	Min	Typ	Max	Min	Typ	Max	
Write Cycle Time		t _{AVAV}	t _{wc}	80	—	—	90	—	—	100	—	—	ns
Address Setup Time		t _{AVWL}	t _{AS}	0	—	—	0	—	—	0	—	—	ns
Address Hold Time		t _{WLAX}	t _{AH}	45	—	—	45	—	—	45	—	—	ns
Data Setup Time		t _{DVWH}	t _{DS}	30	—	—	35	—	—	35	—	—	ns
Data Hold Time		t _{WHDX}	t _{DH}	0	—	—	0	—	—	0	—	—	ns
Output Enable Hold Time	Read	—	t _{OEH}	0	—	—	0	—	—	0	—	—	ns
	Toggle and Data Polling			10	—	—	10	—	—	10	—	—	ns
Read Recover Time Before Write		t _{GHWL}	t _{GHWL}	0	—	—	0	—	—	0	—	—	ns
Read Recover Time Before Write (OE High to CE Low)		t _{GHEL}	t _{GHEL}	0	—	—	0	—	—	0	—	—	ns
CE Setup Time		t _{ELWL}	t _{CS}	0	—	—	0	—	—	0	—	—	ns
WE Setup Time		t _{WLLEL}	t _{WS}	0	—	—	0	—	—	0	—	—	ns
CE Hold Time		t _{WHEH}	t _{CH}	0	—	—	0	—	—	0	—	—	ns
WE Hold Time		t _{EHWH}	t _{WH}	0	—	—	0	—	—	0	—	—	ns
Write Pulse Width		t _{WLWH}	t _{WP}	35	—	—	35	—	—	35	—	—	ns
CE Pulse Width		t _{ELEH}	t _{CP}	35	—	—	35	—	—	35	—	—	ns
Write Pulse Width High		t _{WHWL}	t _{WPH}	25	—	—	30	—	—	30	—	—	ns
CE Pulse Width High		t _{EHEL}	t _{CPH}	25	—	—	30	—	—	30	—	—	ns
Programming Operation	Byte	t _{WHWH1}	t _{WHWH1}	—	8	—	—	8	—	—	8	—	μs
	Word			—	16	—	—	16	—	—	16	—	μs
Sector Erase Operation *1		t _{WHWH2}	t _{WHWH2}	—	1	—	—	1	—	—	1	—	s
V _{CC} Setup Time		—	t _{VCS}	50	—	—	50	—	—	50	—	—	μs
Rise Time to V _{ID} *2		—	t _{VIDR}	500	—	—	500	—	—	500	—	—	ns
Rise Time to V _{ACC} *3		—	t _{VACCR}	500	—	—	500	—	—	500	—	—	ns
Voltage Transition Time *2		—	t _{VLHT}	4	—	—	4	—	—	4	—	—	μs
Write Pulse Width *2		—	t _{WPP}	100	—	—	100	—	—	100	—	—	μs
OE Setup Time to WE Active *2		—	t _{OESP}	4	—	—	4	—	—	4	—	—	μs
CE Setup Time to WE Active *2		—	t _{CSP}	4	—	—	4	—	—	4	—	—	μs
Recover Time From RY/BY		—	t _{RB}	0	—	—	0	—	—	0	—	—	ns
RESET Pulse Width		—	t _{RP}	500	—	—	500	—	—	500	—	—	ns
RESET High Level Period Before Read		—	t _{RH}	200	—	—	200	—	—	200	—	—	ns

(Continued)

MBM29LV320TE/BE_{80/90/10}

(Continued)

Parameter	Symbol		Value									Unit
	JEDEC	Standard	80 (Note)			90 (Note)			10 (Note)			
			Min	Typ	Max	Min	Typ	Max	Min	Typ	Max	
BYTE Switching Low to Output High-Z	—	t _{FLQZ}	—	—	30	—	—	30	—	—	30	ns
BYTE Switching High to Output Active	—	t _{FHQV}	—	—	80	—	—	90	—	—	100	ns
Program/Erase Valid to RY/ $\overline{\text{BY}}$ Delay	—	t _{BUSY}	—	—	90	—	—	90	—	—	90	ns
Delay Time from Embedded Output Enable	—	t _{EOE}	—	—	80	—	—	90	—	—	100	ns
Erase Time-out Time	—	t _{TOW}	50	—	—	50	—	—	50	—	—	μs
Erase Suspend Transition Time	—	t _{SPD}	—	—	20	—	—	20	—	—	20	μs

*1 : This does not include the preprogramming time.

*2 : This timing is for Sector Group Protection operation.

*3 : This timing is limited for Accelerated Program operation only.

■ ERASE AND PROGRAMMING PERFORMANCE

Parameter	Limits			Unit	Comments
	Min	Typ	Max		
Sector Erase Time	—	1	10	s	Excludes programming time prior to erasure
Word Programming Time	—	16	360	μs	Excludes system-level overhead
Byte Programming Time	—	8	300	μs	
Chip Programming Time	—	—	100	s	Excludes system-level overhead
Program/Erase Cycle	100,000	—	—	cycle	—

■ TSOP (1) PIN CAPACITANCE

Parameter	Symbol	Condition	Value		Unit
			Typ	Max	
Input Capacitance	C _{IN}	V _{IN} = 0	6.0	7.5	pF
Output Capacitance	C _{OUT}	V _{OUT} = 0	8.5	12.0	pF
Control Pin Capacitance	C _{IN2}	V _{IN} = 0	8.0	10.0	pF
$\overline{\text{WP}}/\text{ACC}$ Pin Capacitance	C _{IN3}	V _{IN} = 0	15.0	20.0	pF

Notes : • Test conditions T_A = + 25 °C, f = 1.0 MHz
 • DQ₁₅/A-1 pin capacitance is stipulated by output capacitance.





■ FBGA PIN CAPACITANCE

Parameter	Symbol	Condition	Value		Unit
			Typ	Max	
Input Capacitance	C _{IN}	V _{IN} = 0	6.0	7.5	pF
Output Capacitance	C _{OUT}	V _{OUT} = 0	8.5	12.0	pF
Control Pin Capacitance	C _{IN2}	V _{IN} = 0	8.0	10.0	pF
$\overline{\text{WP}}/\text{ACC}$ Pin Capacitance	C _{IN3}	V _{IN} = 0	15.0	20.0	pF

Notes : • Test conditions T_A = + 25 °C, f = 1.0 MHz
 • DQ₁₅/A-1 pin capacitance is stipulated by output capacitance.

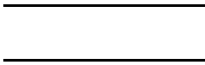
TIMING DIAGRAM

- Key to Switching Waveforms

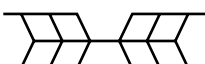
WAVEFORM	INPUTS	OUTPUTS
	Must Be Steady	Will Be Steady
	May Change from H to L	Will Change from H to L
	May Change from L to H	Will Change from L to H
	"H" or "L" Any Change Permitted	Changing State Unknown
	Does Not Apply	Center Line is High-Impedance "Off" State

1. Read Operation Timing Diagram

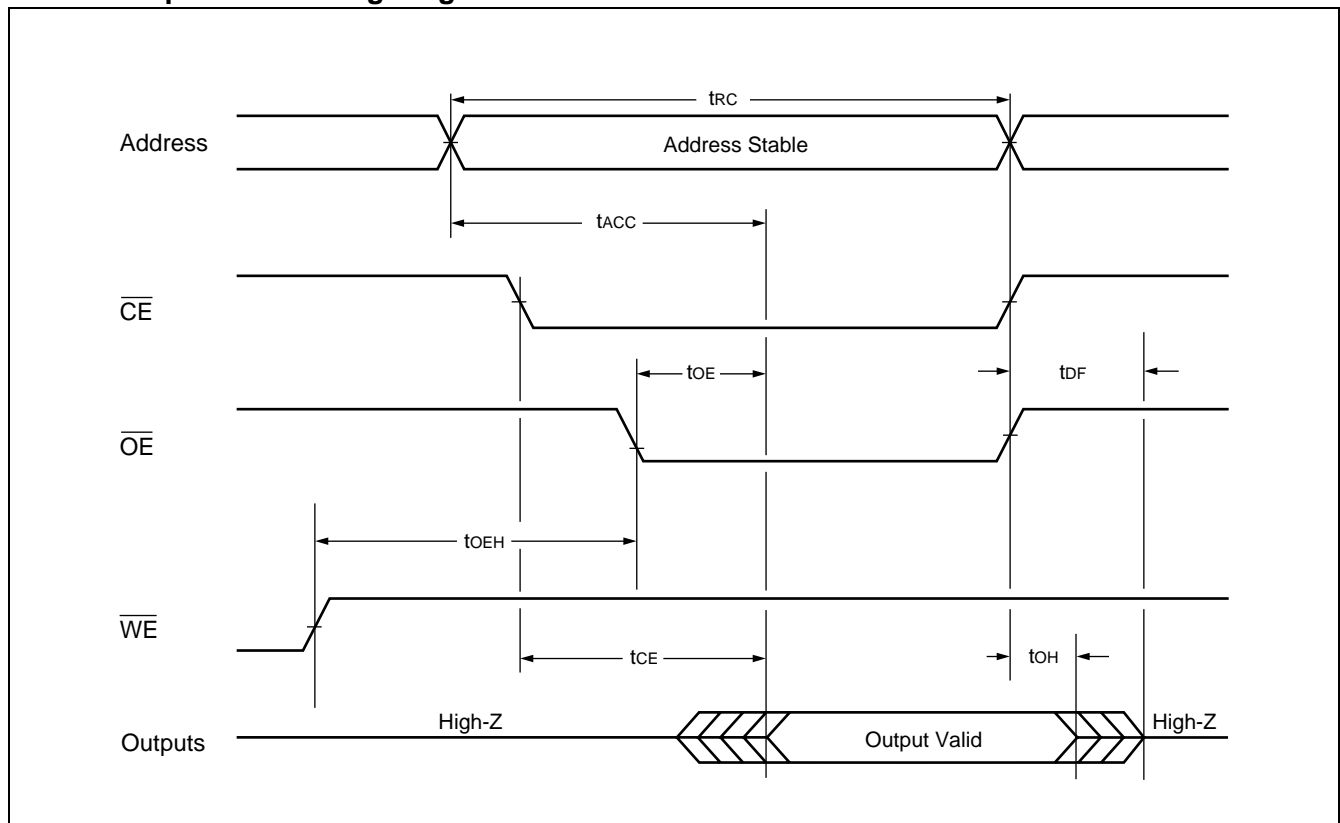

2. Hardware Reset/Read Operation Timing Diagram

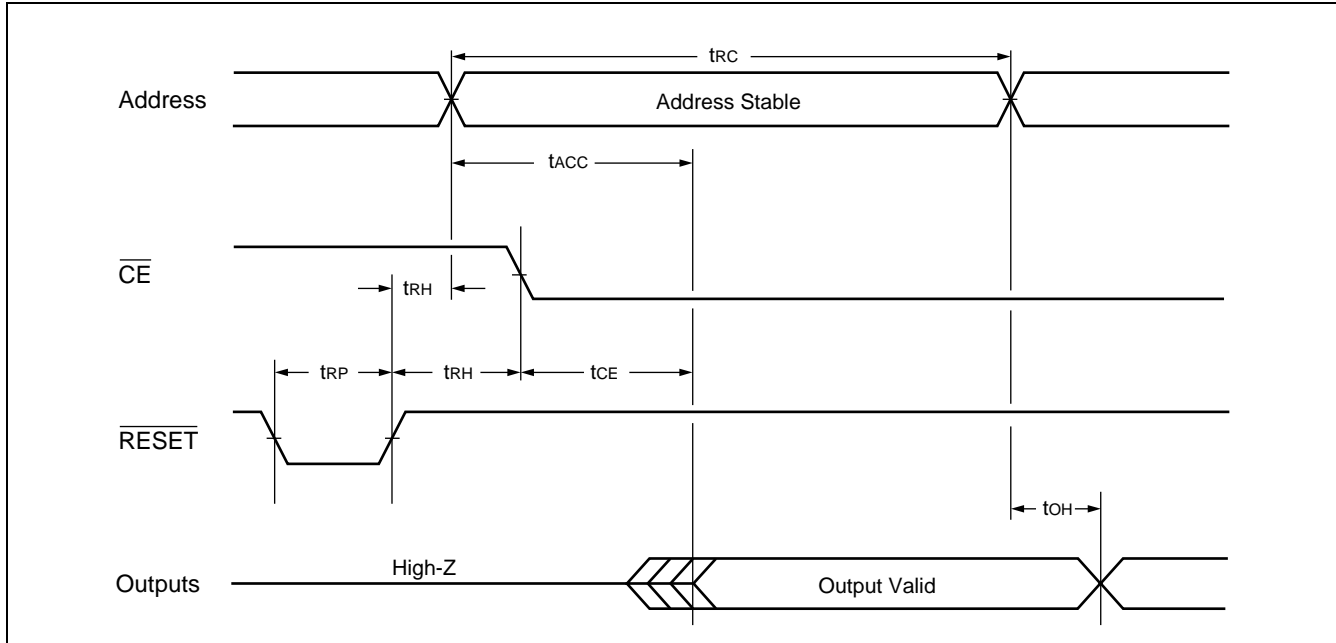

3. Alternate \overline{WE} Controlled Program Operation Timing Diagram

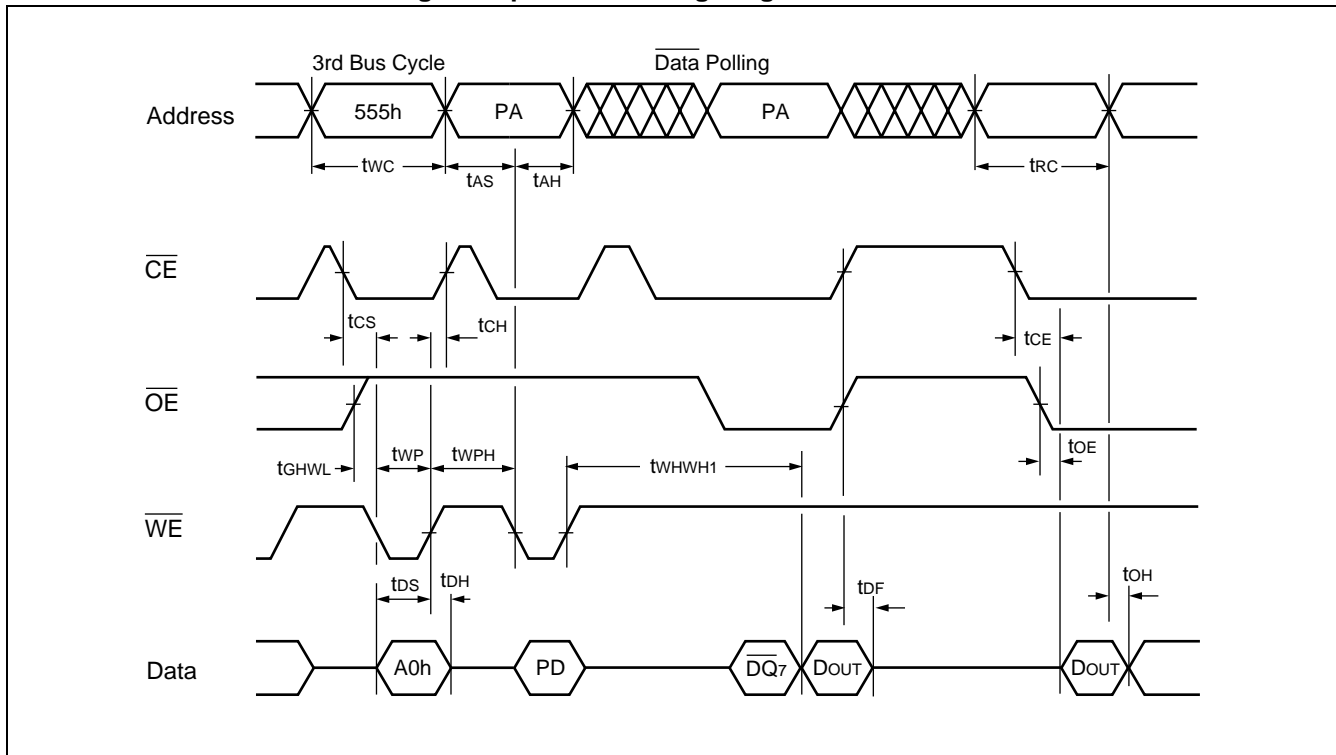

- Notes :
- PA is address of the memory location to be programmed.
 - PD is data to be programmed at byte address.
 - \overline{DQ}_7 is the output of the complement of the data written to the device.
 - DOUT is the output of the data written to the device.
 - Figure indicates last two bus cycles out of four bus cycle sequence.
 - These waveforms are for the $\times 16$ mode. The addresses differ from $\times 8$ mode.

4. Alternate $\overline{\text{CE}}$ Controlled Program Operation Timing Diagram

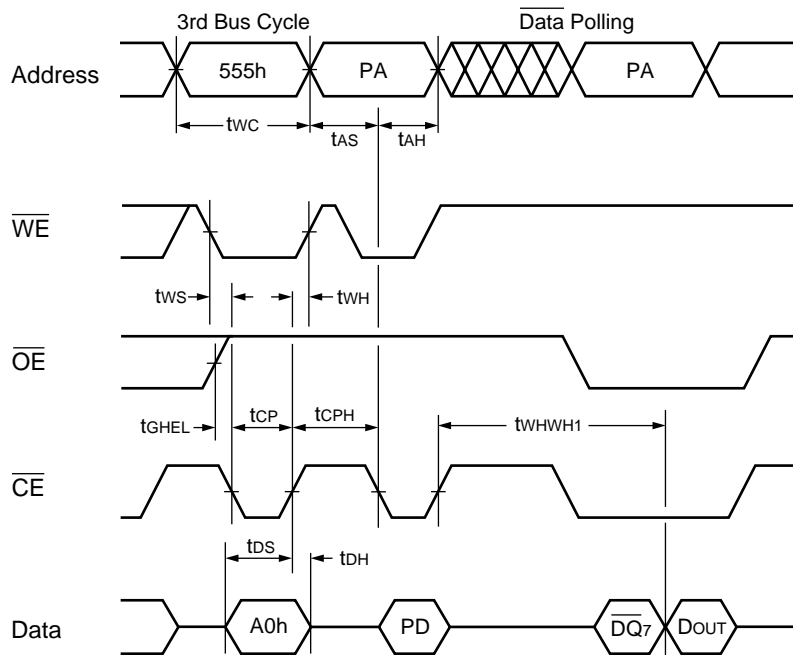

- Notes :
- PA is address of the memory location to be programmed.
 - PD is data to be programmed at byte address.
 - $\overline{\text{DQ}}_7$ is the output of the complement of the data written to the device.
 - D_{OUT} is the output of the data written to the device.
 - Figure indicates last two bus cycles out of four bus cycle sequence.
 - These waveforms are for the $\times 16$ mode. The addresses differ from $\times 8$ mode.

5. Chip/Sector Erase Operation Timing Diagram

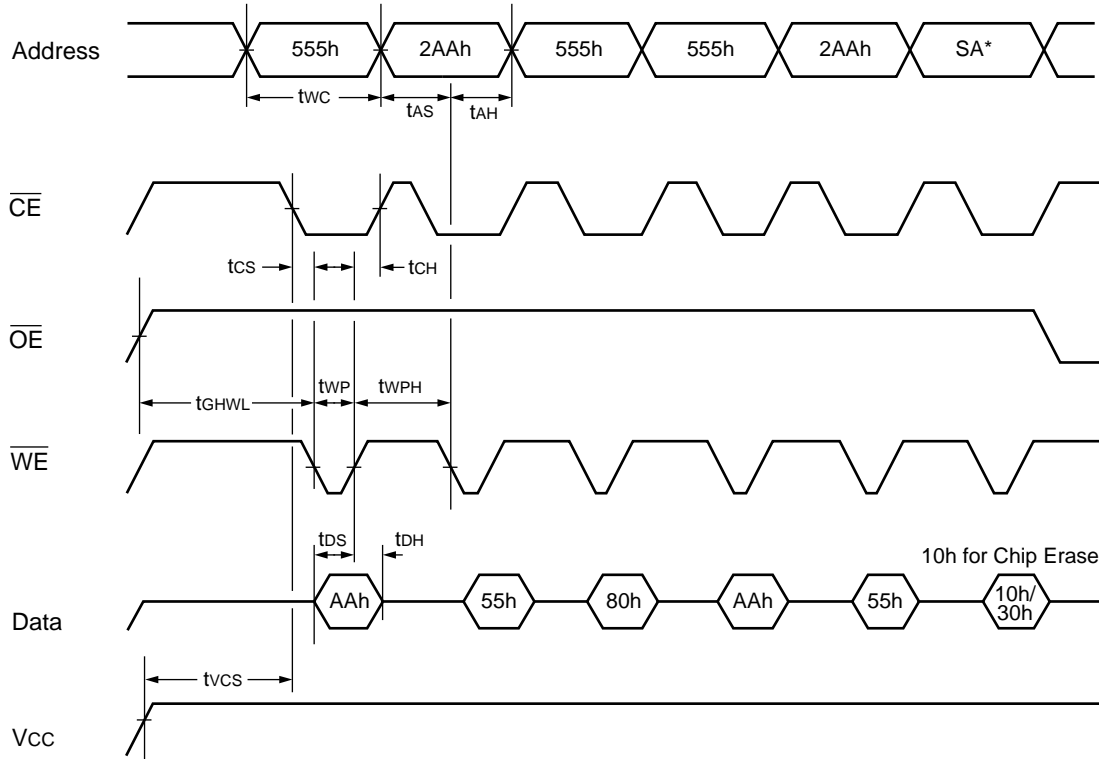

* : SA is the sector address for Sector Erase. Addresses = 555h (Word), AAh (Byte) for Chip Erase.

Note : These waveforms are for the $\times 16$ mode. The addresses differ from $\times 8$ mode.

6. Data Polling during Embedded Algorithm Operation Timing Diagram

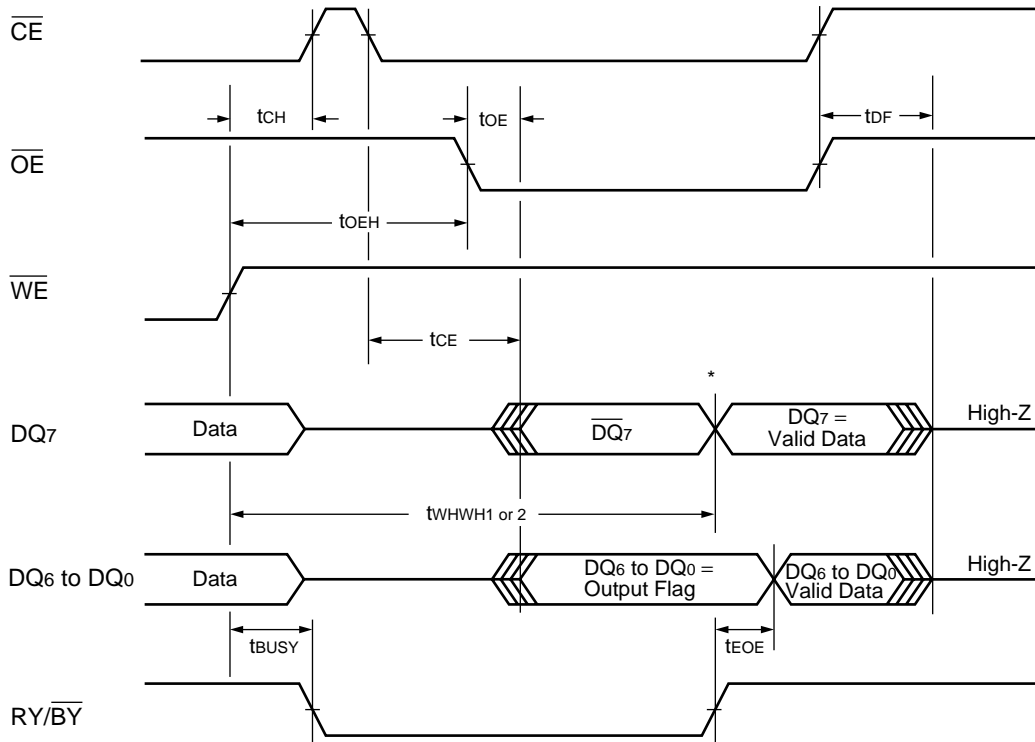

* : DQ_7 = Valid Data (The device has completed the Embedded operation) .

7. Toggle Bit I during Embedded Algorithm Operation Timing Diagram

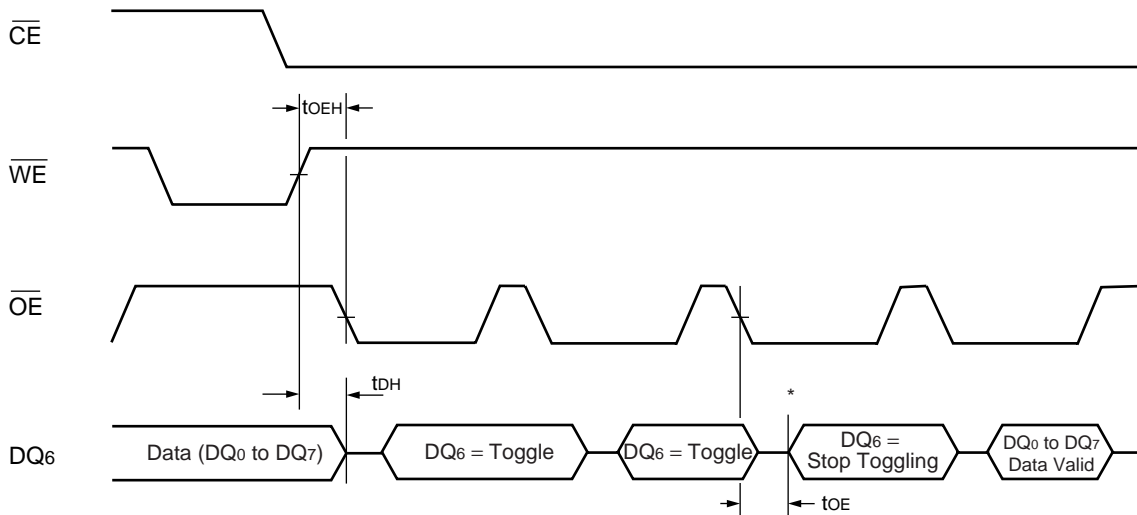

* : DQ_6 = Stops toggling. (The device has completed the Embedded operation.)

8. DQ₂ vs. DQ₆

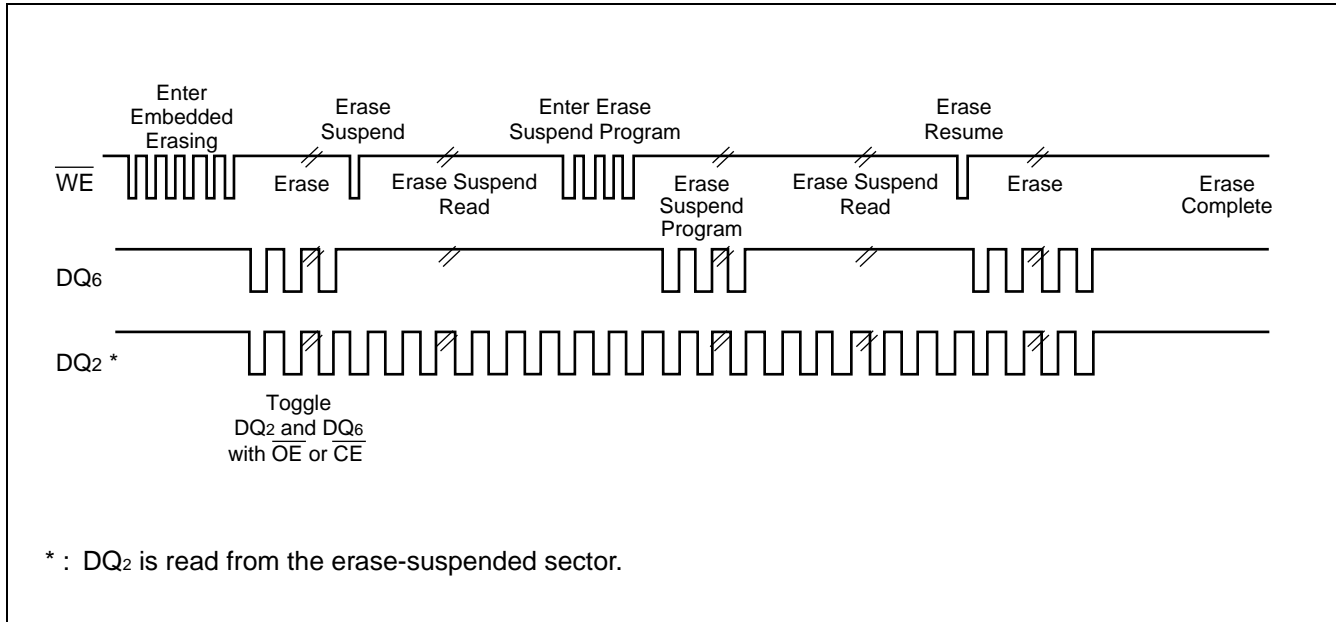

9. RY/ \overline{BY} Timing Diagram during Program/Erase Operations

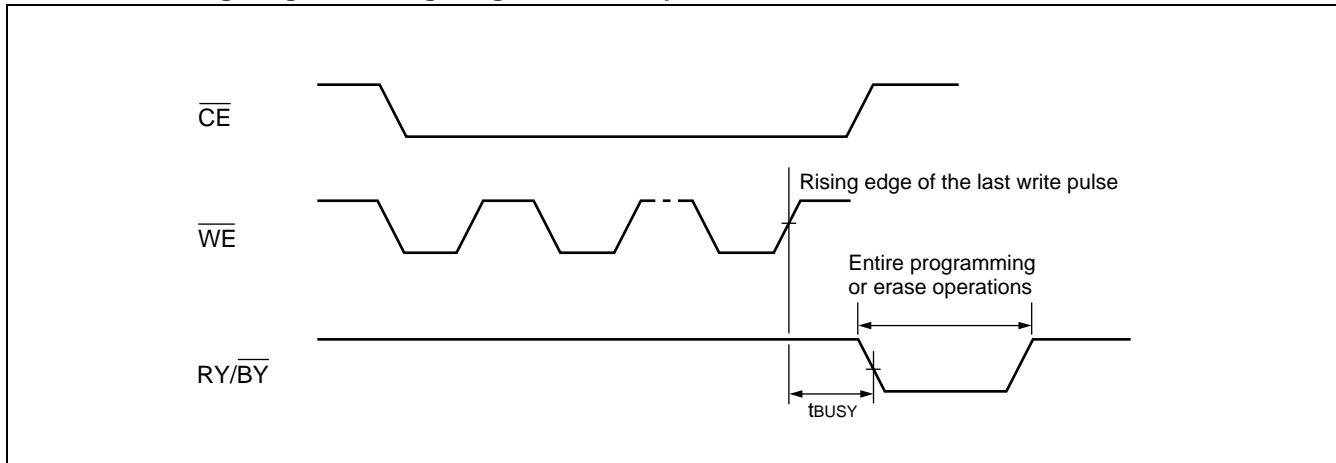

10. \overline{RESET} , RY/ \overline{BY} Timing Diagram

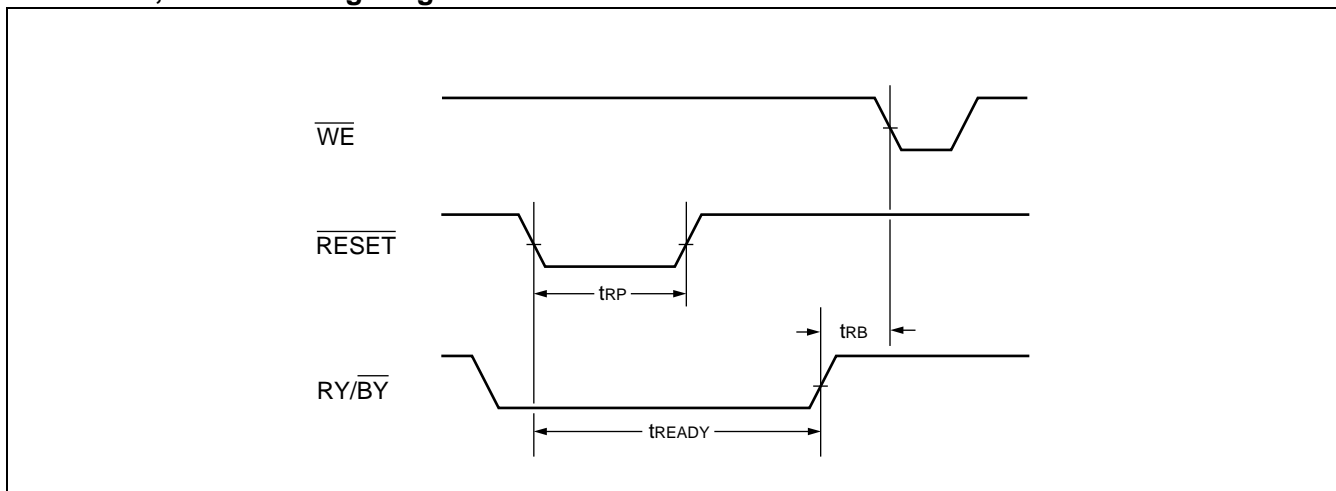

11. Word Mode Configuration Timing Diagram

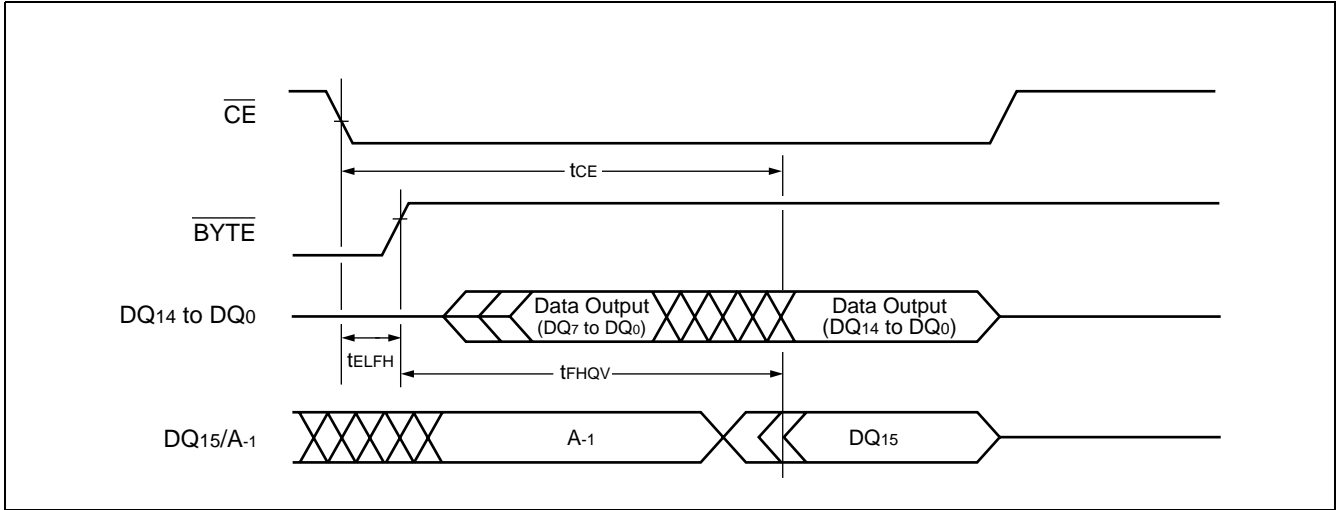

12. Byte Mode Configuration Timing Diagram

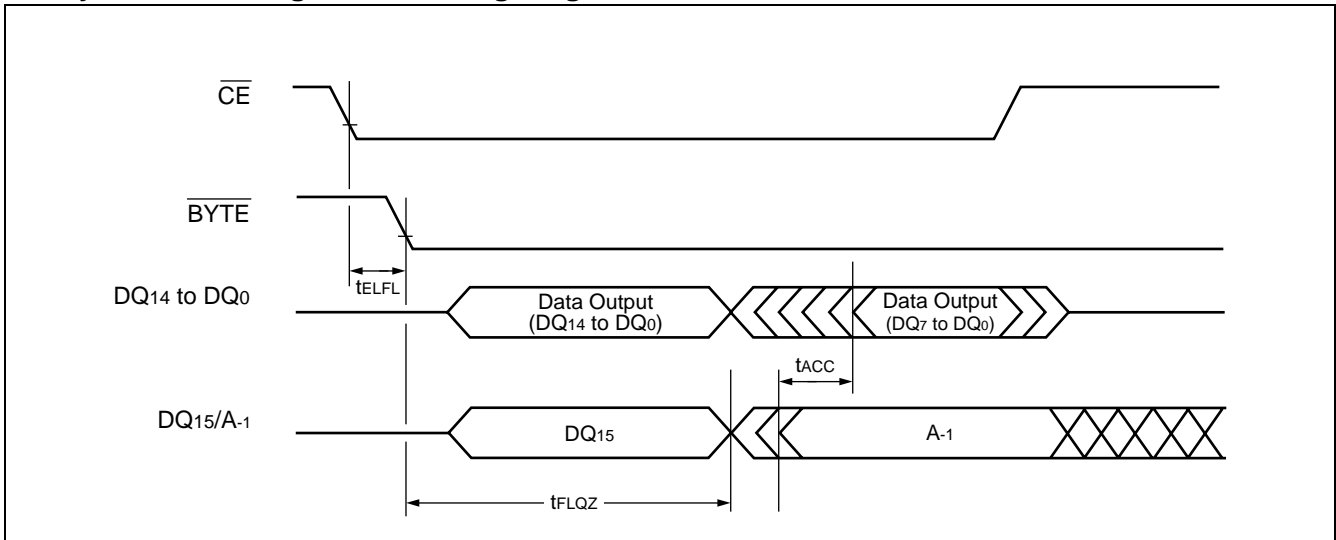

13. \overline{BYTE} Timing Diagram for Write Operations

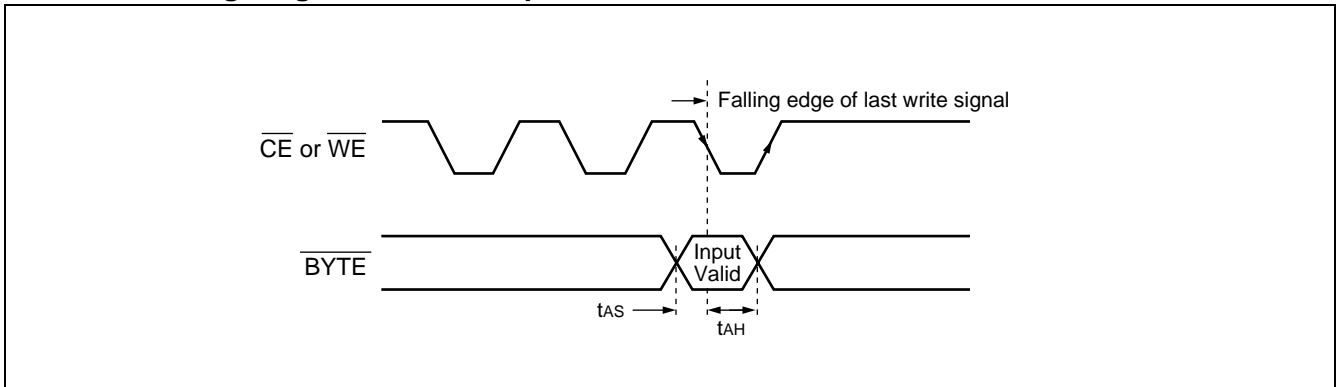

14. Sector Group Protection Timing Diagram

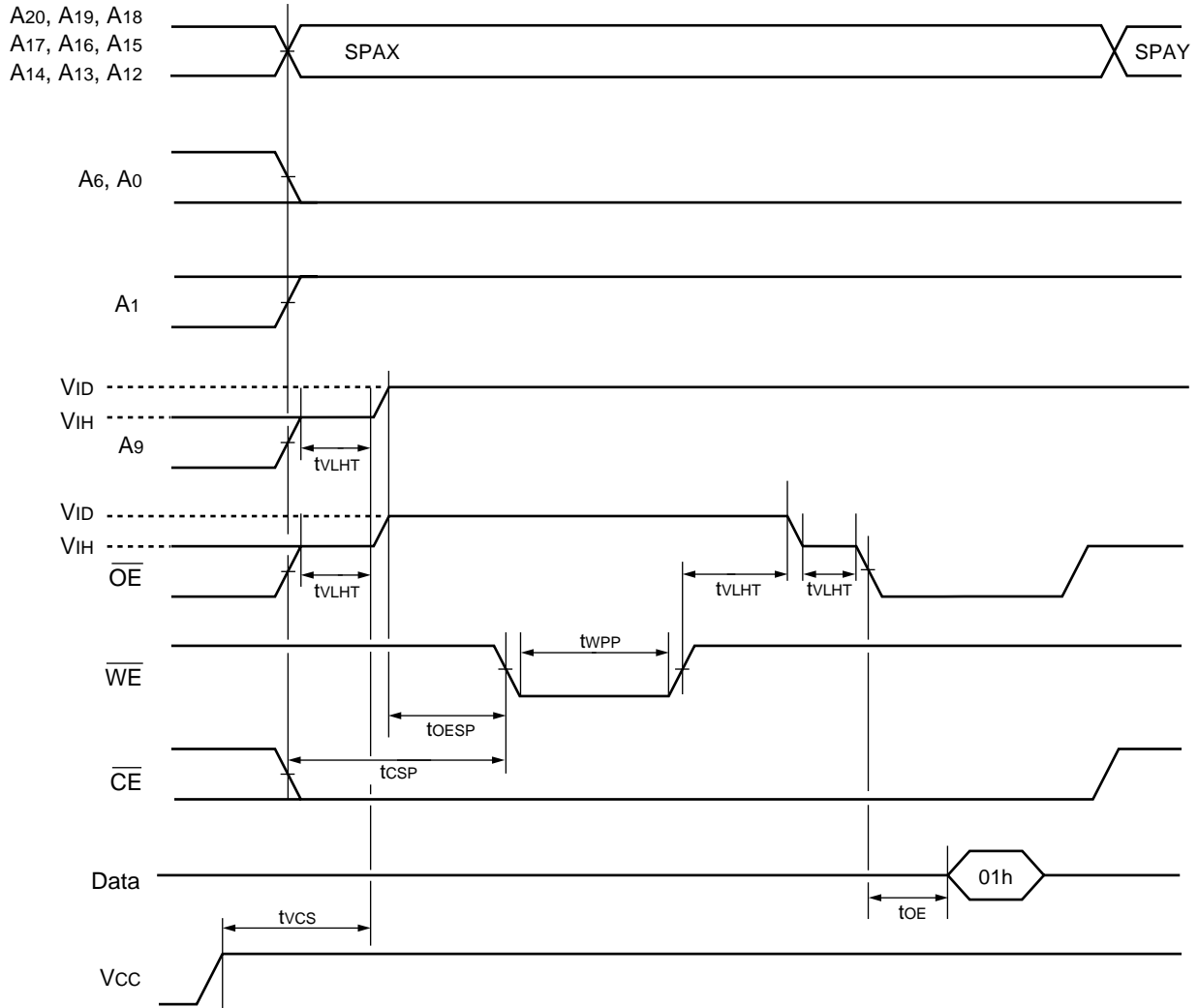

SPAX : Sector Group Address to be protected.
 SPAY : Next Sector Group Address to be protected.

Note : A-1 is V_{IL} on byte mode.

15. Temporary Sector Group Unprotection Timing Diagram

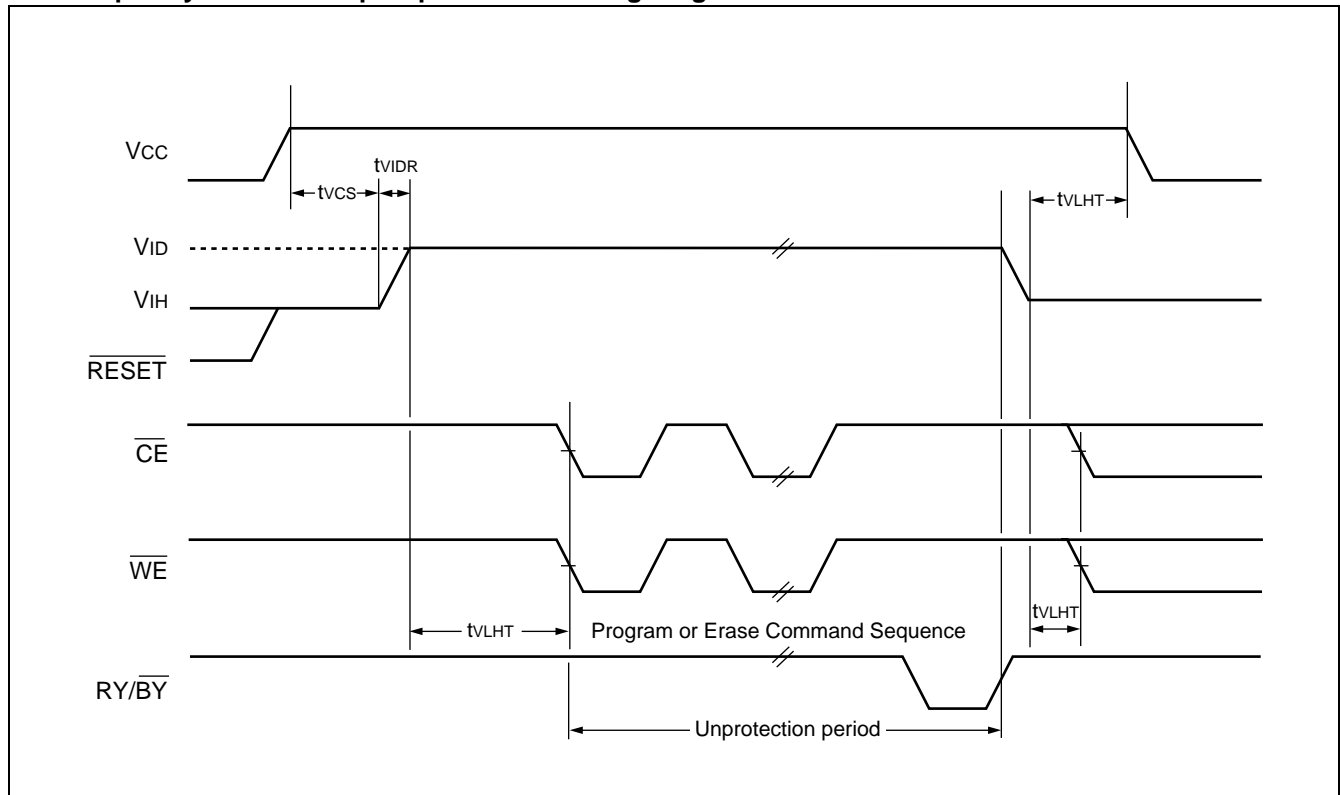

16. Extended Sector Group Protection Timing Diagram

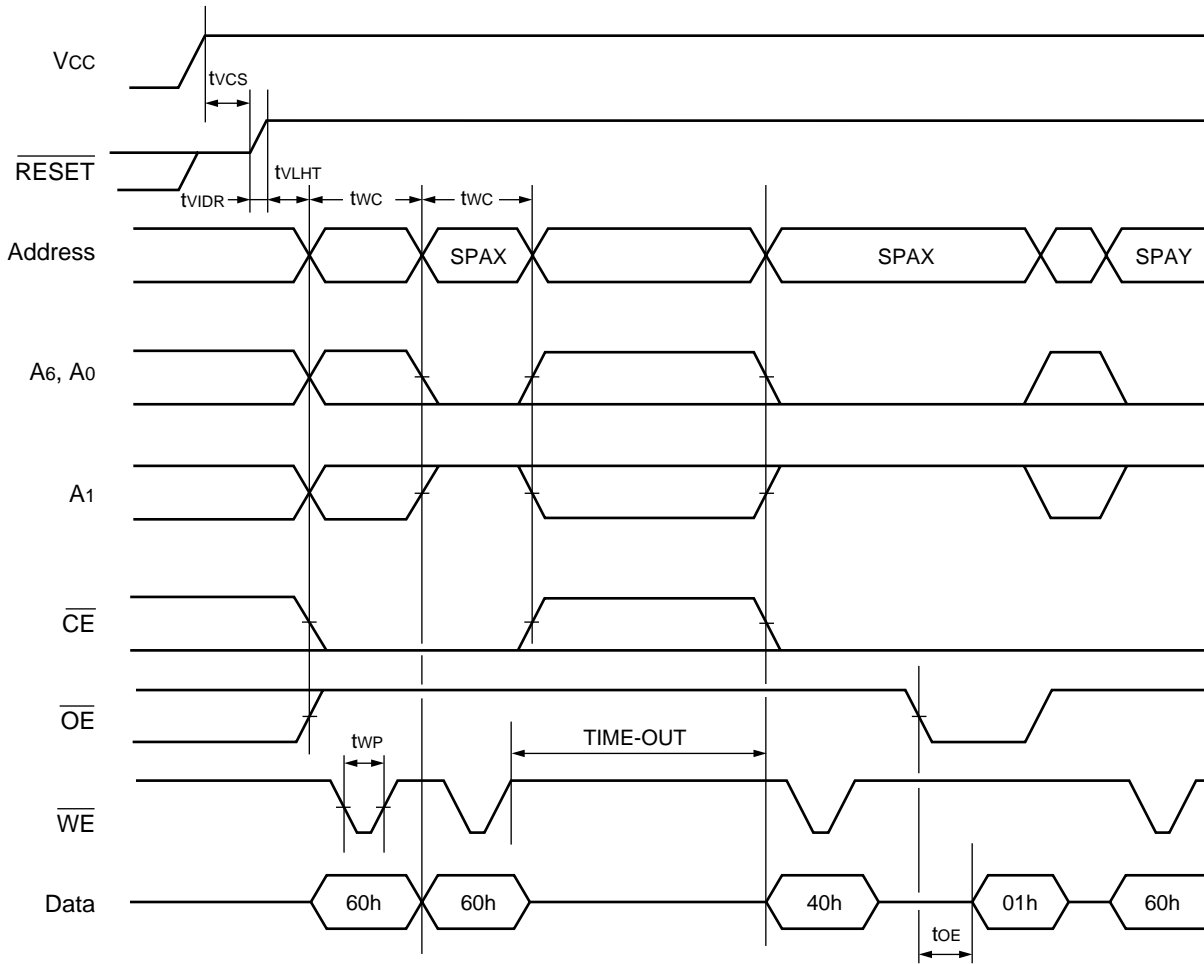

SPAX : Sector Group Address to be protected
 SPAY : Next Sector Group Address to be protected
 TIME-OUT : Time-Out window = 250 μs (Min)

17. Accelerated Program Timing Diagram

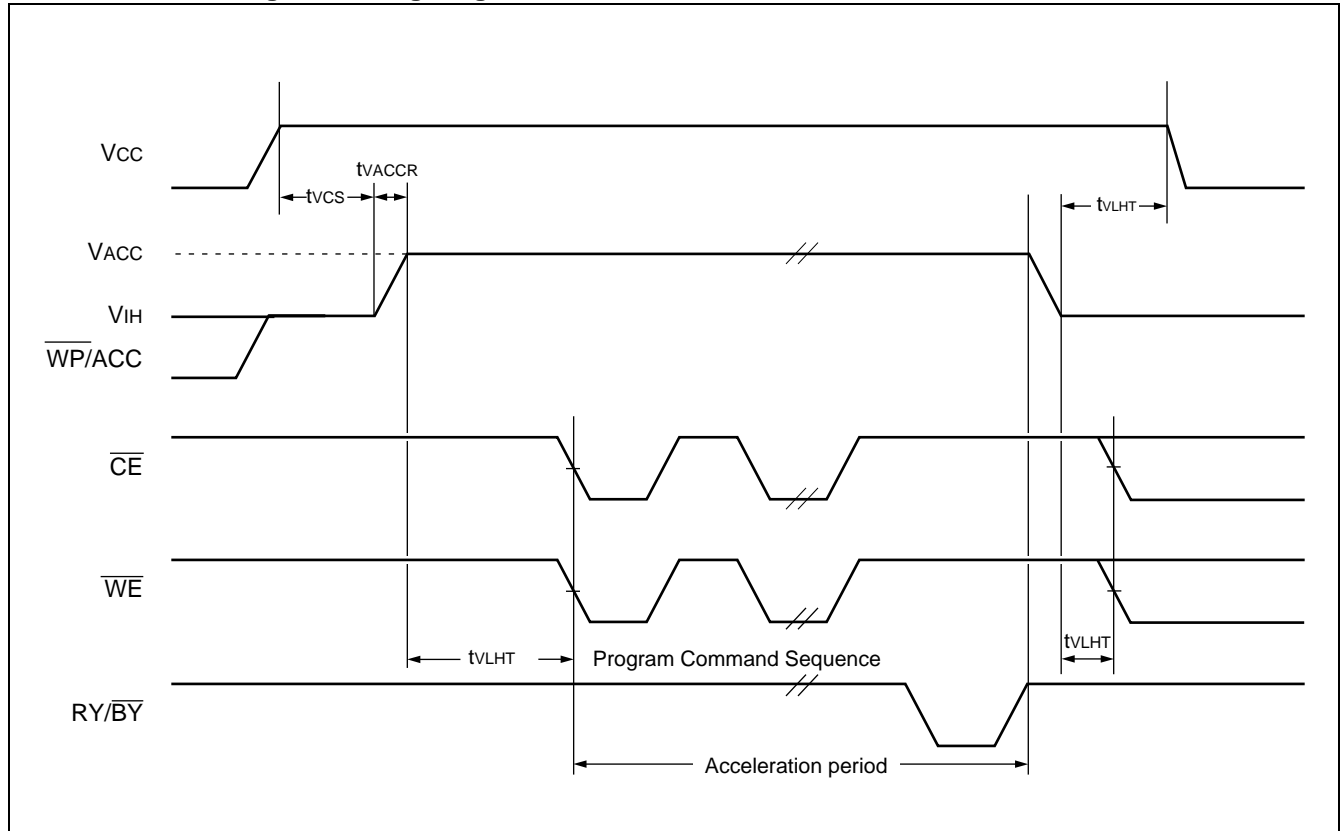

■ FLOW CHART

1. Embedded Program™ Algorithm

EMBEDDED ALGORITHM

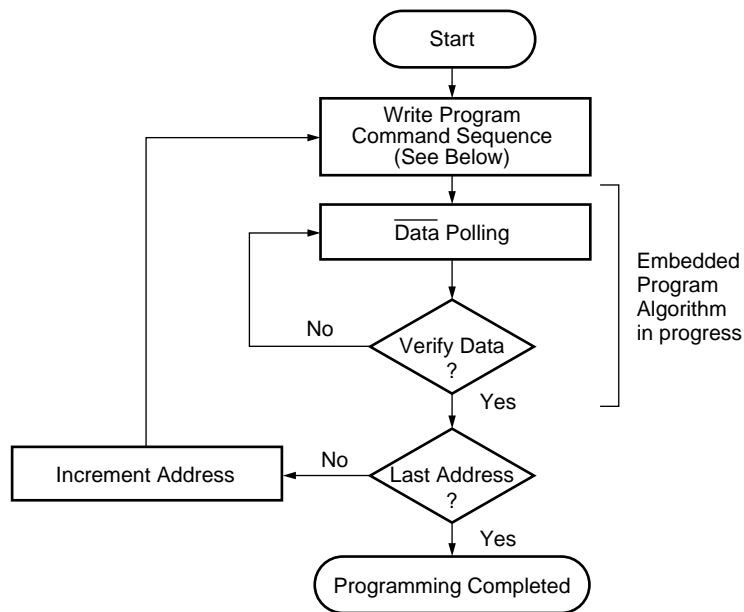

Program Command Sequence (Address/Command):

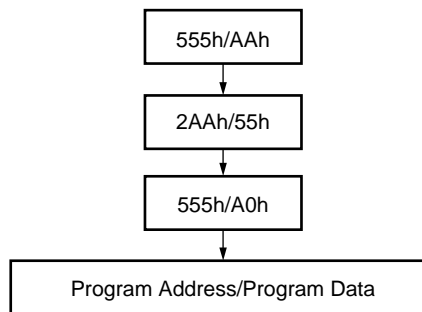

- Notes:
- The sequence is applied for × 16 mode.
 - The addresses differ from × 8 mode.

2. Embedded Erase™ Algorithm

EMBEDDED ALGORITHM

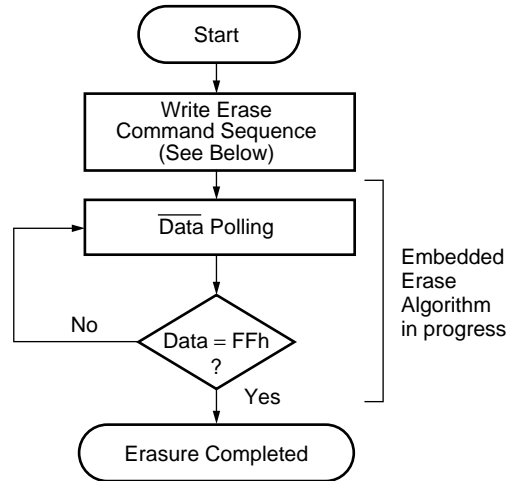

Chip Erase Command Sequence
(Address/Command):

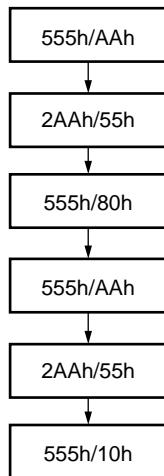

Individual Sector/Multiple Sector
Erase Command Sequence
(Address/Command):

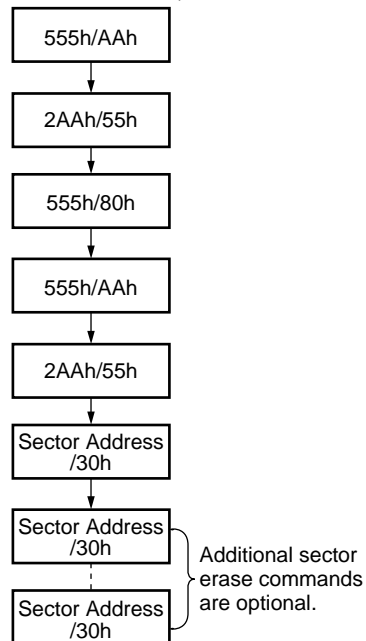

Note : The sequence is applied for × 16 mode.
The addresses differ from × 8 mode.

3. Data Polling Algorithm

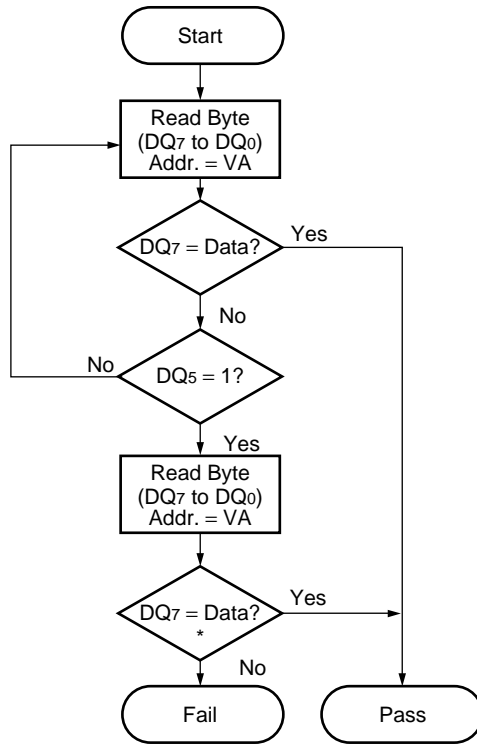

VA = Address for programming
 = Any of the sector addresses within the sector being erased during sector erase or multiple erases operation
 = Any of the sector addresses within the sector not being protected during sector erase or multiple sector erases operation

* : DQ₇ is rechecked even if DQ₅ = "1" because DQ₇ may change simultaneously with DQ₅.

4. Toggle Bit Algorithm

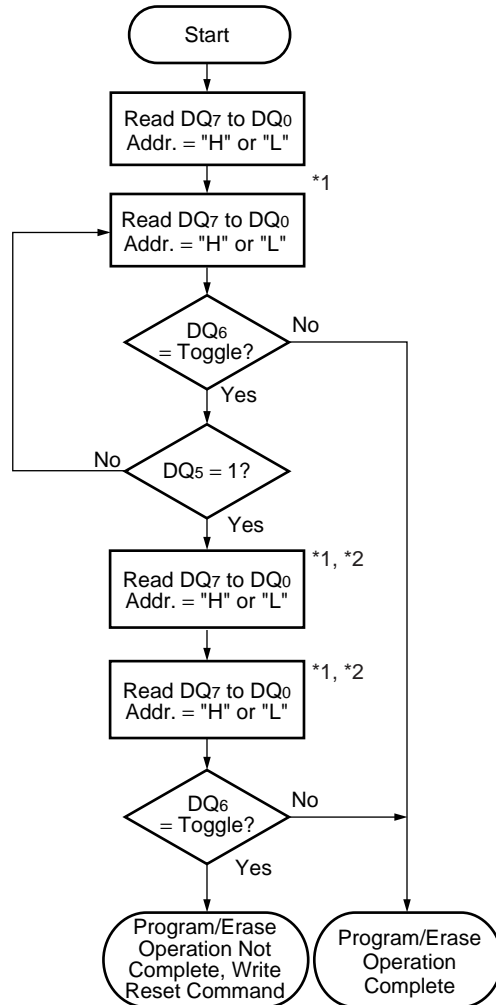

*1 : Read toggle bit twice to determine whether it is toggling.

*2 : Recheck toggle bit because it may stop toggling as DQ₅ changes to "1".

5. Sector Group Protection Algorithm

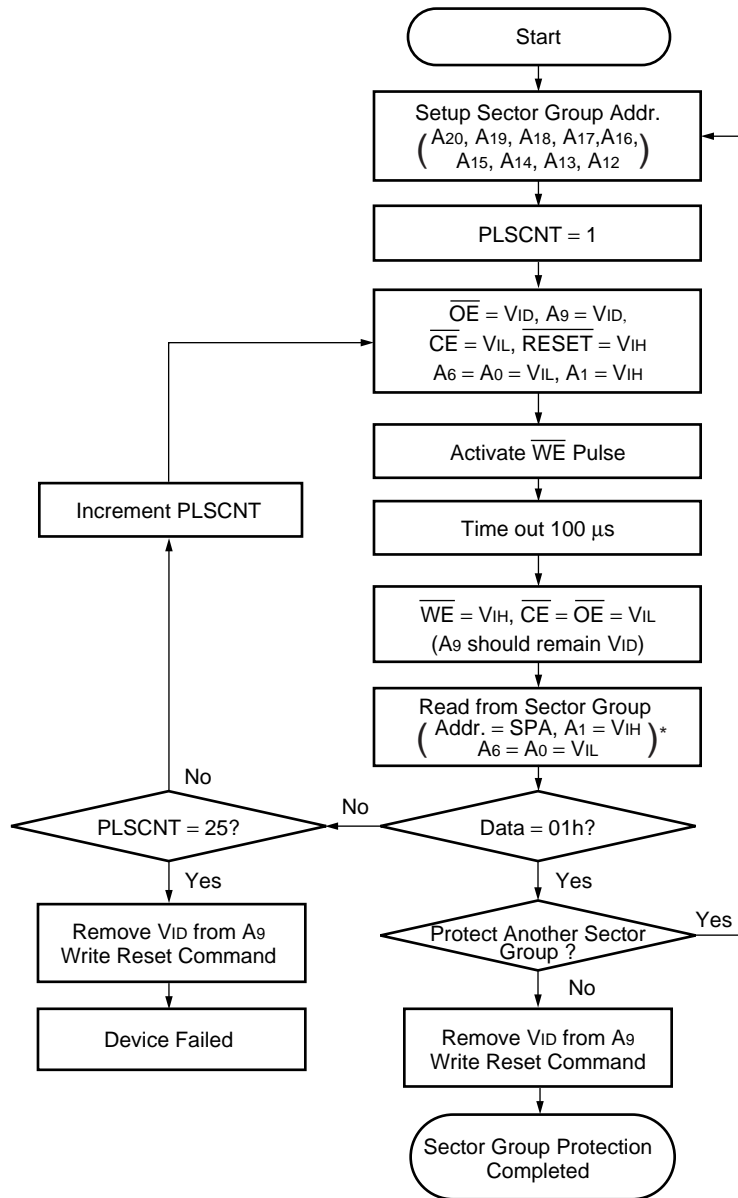

* : A-1 is V_{IL} on byte mode.

6. Temporary Sector Group Unprotection Algorithm

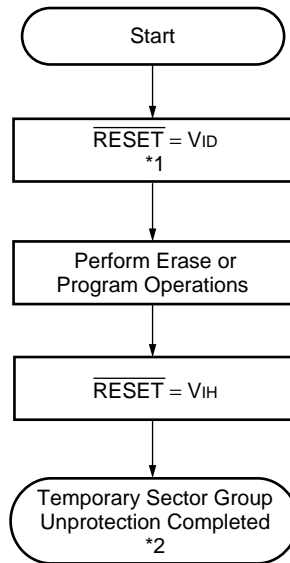

*1 : All protected sectors groups are unprotected.

*2 : All previously protected sectors groups are protected once again.

7. Extended Sector Group Protection Algorithm

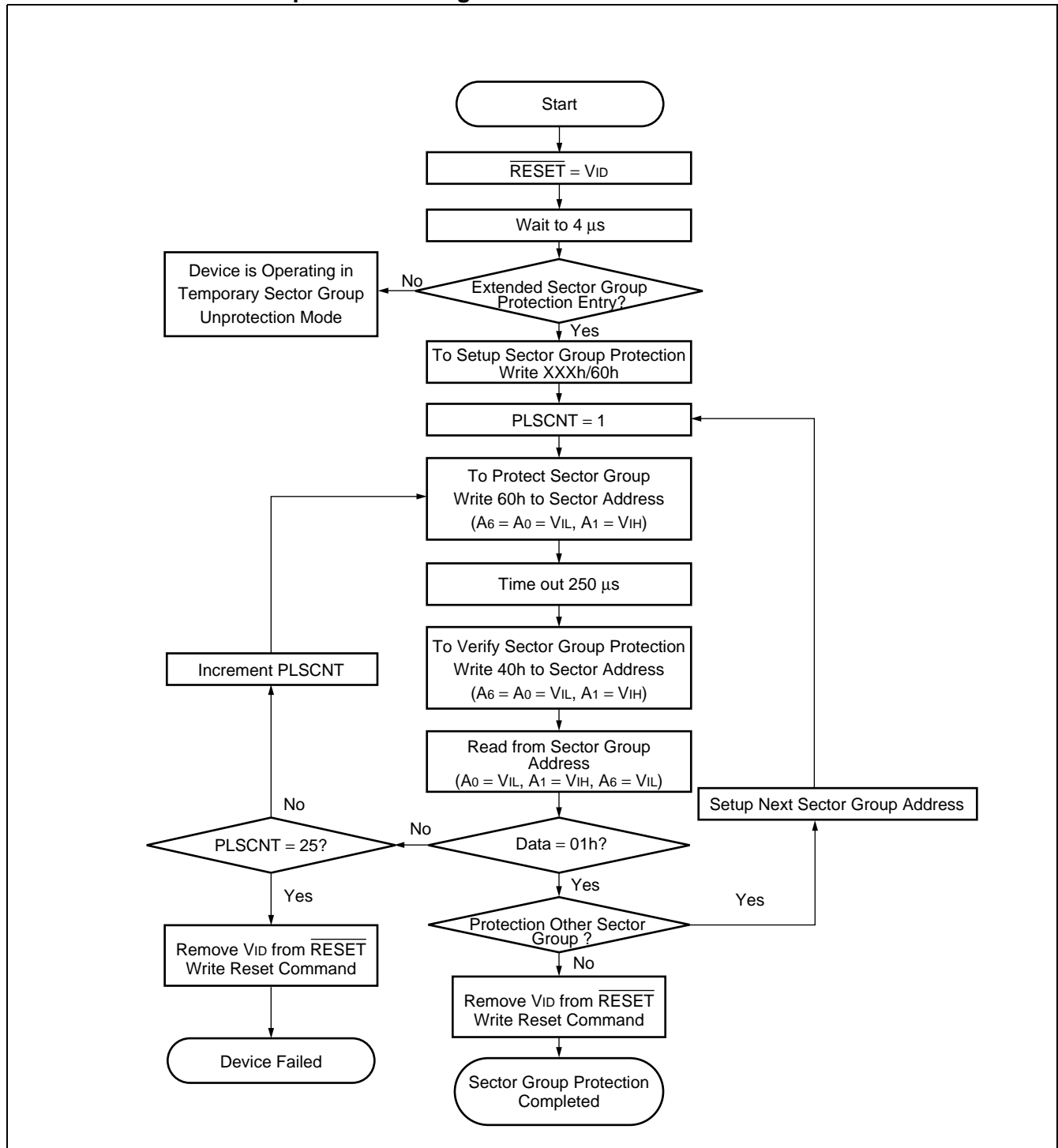

8. Embedded Program™ Algorithm for Fast Mode

FAST MODE ALGORITHM

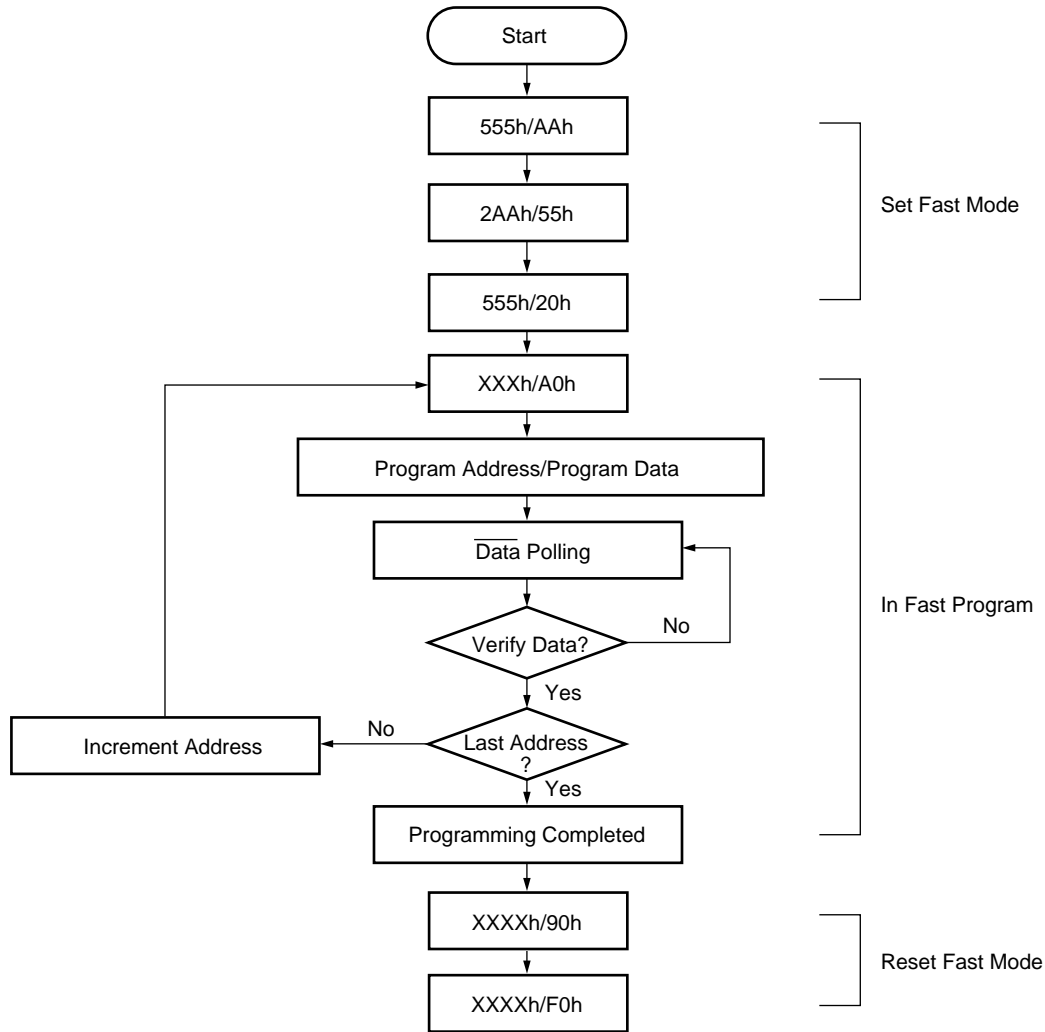

- Notes :
- The sequence is applied for × 16 mode.
 - The addresses differ from × 8 mode.

ORDERING INFORMATION

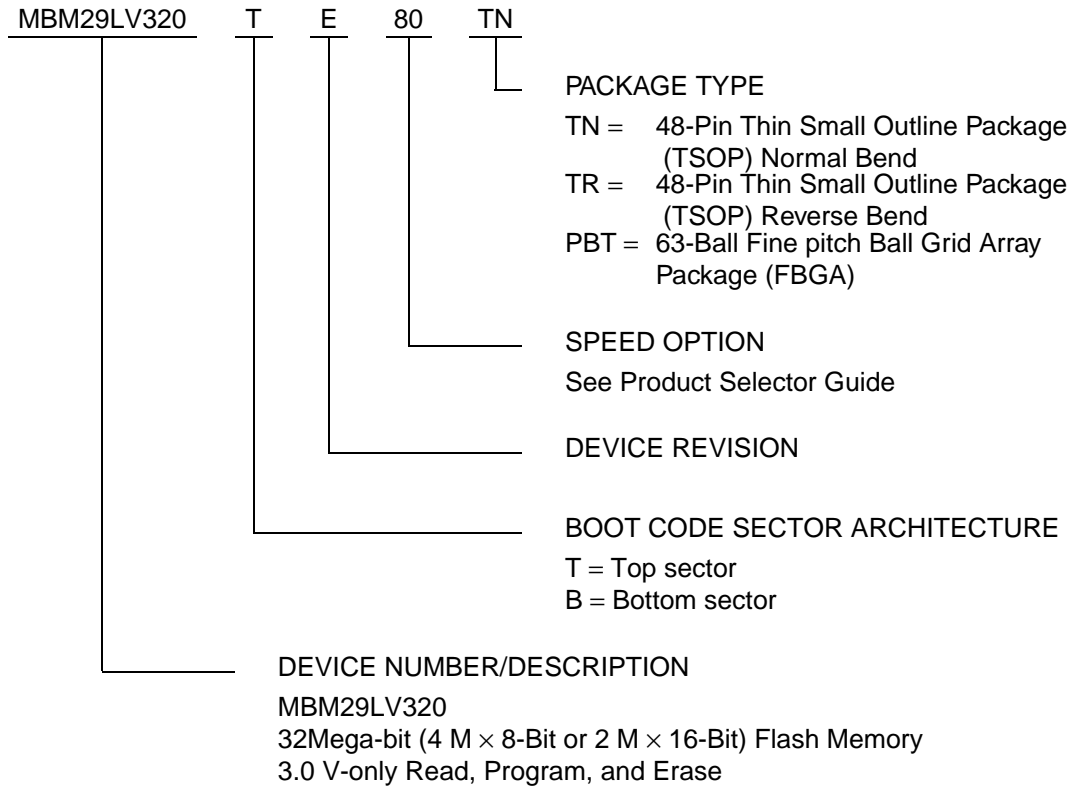

Part No.	Package	Access Time(ns)	Remarks
MBM29LV320TE80TN	48-pin plastic TSOP (1) (FPT-48P-M19) Normal Bend	80	Top Sector
MBM29LV320TE90TN		90	
MBM29LV320TE10TN		100	
MBM29LV320TE80TR	48-pin plastic TSOP (1) (FPT-48P-M20) Reverse Bend	80	
MBM29LV320TE90TR		90	
MBM29LV320TE10TR		100	
MBM29LV320TE80PBT	63-pin plastic FBGA (BGA-63P-M01)	80	
MBM29LV320TE90PBT		90	
MBM29LV320TE10PBT		100	
MBM29LV320BE80TN	48-pin plastic TSOP (1) (FPT-48P-M19) Normal Bend	80	Bottom Sector
MBM29LV320BE90TN		90	
MBM29LV320BE10TN		100	
MBM29LV320BE80TR	48-pin plastic TSOP (1) (FPT-48P-M20) Reverse Bend	80	
MBM29LV320BE90TR		90	
MBM29LV320BE10TR		100	
MBM29LV320BE80PBT	63-pin plastic FBGA (BGA-63P-M01)	80	
MBM29LV320BE90PBT		90	
MBM29LV320BE10PBT		100	

MBM29LV320TE/BE_{80/90/10}

PACKAGE DIMENSIONS

48-pin plastic TSOP(1)
(FPT-48P-M19)

- Note 1) *: Values do not include resin protrusion.
Resin protrusion and gate protrusion are +0.15(.006)Max(each side).
Note 2) Pins width and pins thickness include plating thickness.
Note 3) Pins width do not include tie bar cutting remainder.

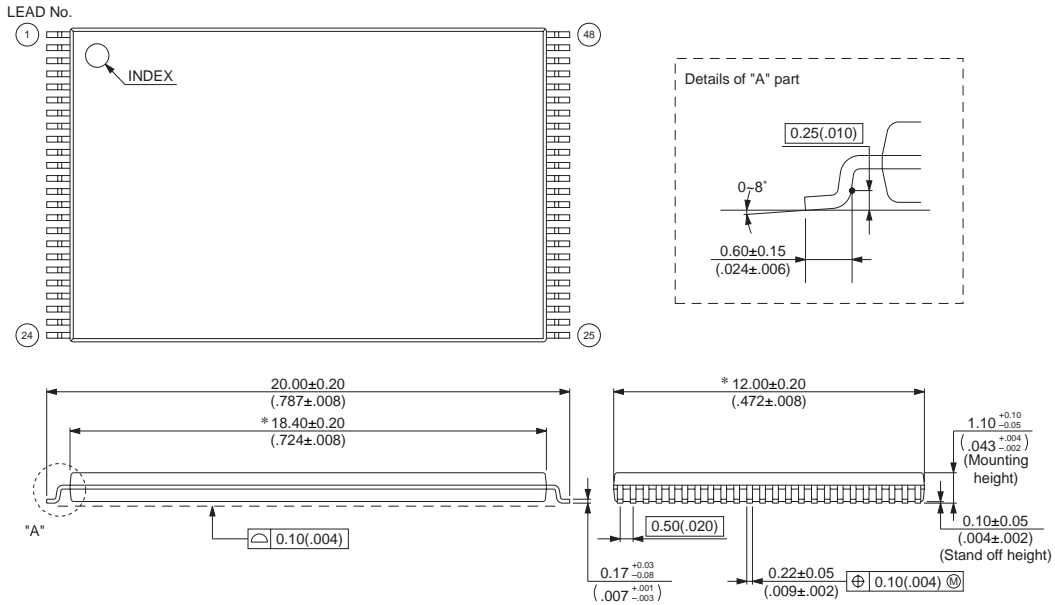

© 2003 FUJITSU LIMITED F48029S-c-6-7

Dimensions in mm (inches) .

Note : The values in parentheses are reference values.

48-pin plastic TSOP(1)
(FPT-48P-M20)

- Note 1) *: Values do not include resin protrusion.
Resin protrusion and gate protrusion are +0.15(.006)Max(each side).
Note 2) Pins width and pins thickness include plating thickness.
Note 3) Pins width do not include tie bar cutting remainder.

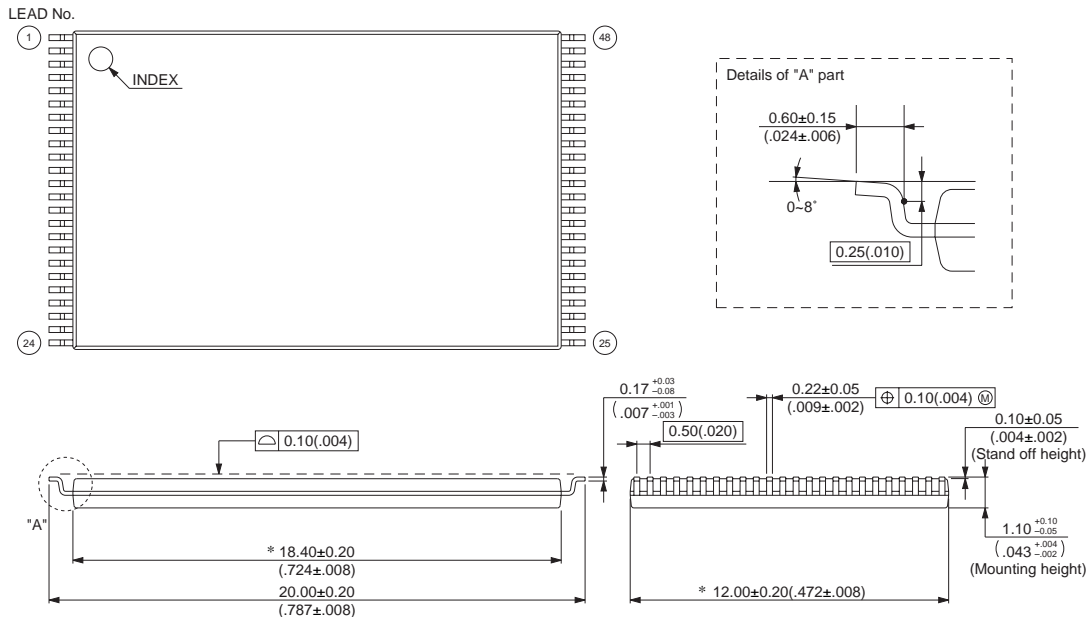

© 2003 FUJITSU LIMITED F48030S-c-6-7

Dimensions in mm (inches) .

Note : The values in parentheses are reference values.

(Continued)

(Continued)

63-pin plastic FBGA (BGA-63P-M01)

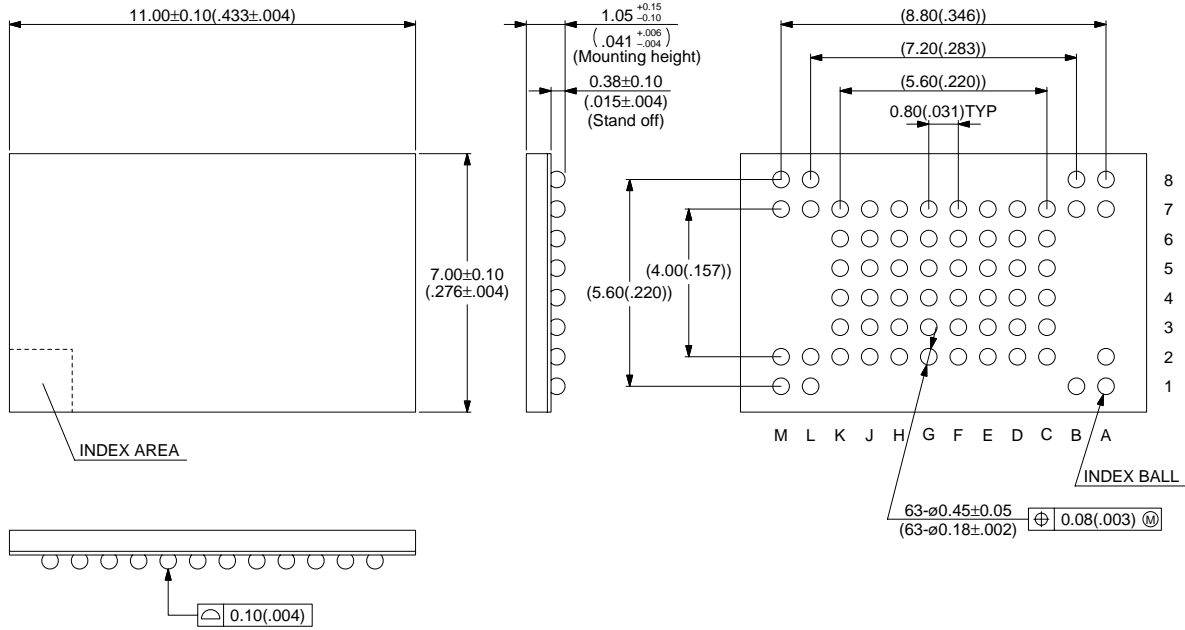

© 2001 FUJITSU LIMITED B63001S-c-2-2

Dimensions in mm (inches) .

Note : The values in parentheses are reference values.

FUJITSU LIMITED

All Rights Reserved.

The contents of this document are subject to change without notice. Customers are advised to consult with FUJITSU sales representatives before ordering.

The information, such as descriptions of function and application circuit examples, in this document are presented solely for the purpose of reference to show examples of operations and uses of Fujitsu semiconductor device; Fujitsu does not warrant proper operation of the device with respect to use based on such information. When you develop equipment incorporating the device based on such information, you must assume any responsibility arising out of such use of the information. Fujitsu assumes no liability for any damages whatsoever arising out of the use of the information.

Any information in this document, including descriptions of function and schematic diagrams, shall not be construed as license of the use or exercise of any intellectual property right, such as patent right or copyright, or any other right of Fujitsu or any third party or does Fujitsu warrant non-infringement of any third-party's intellectual property right or other right by using such information. Fujitsu assumes no liability for any infringement of the intellectual property rights or other rights of third parties which would result from the use of information contained herein.

The products described in this document are designed, developed and manufactured as contemplated for general use, including without limitation, ordinary industrial use, general office use, personal use, and household use, but are not designed, developed and manufactured as contemplated (1) for use accompanying fatal risks or dangers that, unless extremely high safety is secured, could have a serious effect to the public, and could lead directly to death, personal injury, severe physical damage or other loss (i.e., nuclear reaction control in nuclear facility, aircraft flight control, air traffic control, mass transport control, medical life support system, missile launch control in weapon system), or (2) for use requiring extremely high reliability (i.e., submersible repeater and artificial satellite).

Please note that Fujitsu will not be liable against you and/or any third party for any claims or damages arising in connection with above-mentioned uses of the products.

Any semiconductor devices have an inherent chance of failure. You must protect against injury, damage or loss from such failures by incorporating safety design measures into your facility and equipment such as redundancy, fire protection, and prevention of over-current levels and other abnormal operating conditions.

If any products described in this document represent goods or technologies subject to certain restrictions on export under the Foreign Exchange and Foreign Trade Law of Japan, the prior authorization by Japanese government will be required for export of those products from Japan.