

TLP3110

MEASUREMENT INSTRUMENTS

LOGIC IC TESTERS / MEMORY TESTERS

BOARD TESTERS / SCANNERS

The TOSHIBA MINI FLAT PHOTO RELAY TLP3110 is a small outline photo relay, suitable for surface mount assembly. The TLP3110 consists of a GaAs infrared emitting diode optically coupled to a photo-MOSFET in a 4 pin lead package (MFSOP6), and has characteristics of small off-state current and small output terminal capacitance, which enable the TLP3110 to be applied to measurement instruments.

- 1-Form-A
- Peak Off-State Voltage : 60 V (MIN.)
- Trigger LED Current : 4 mA (MAX.)
- On-State Current : 350 mA (MAX.)
- On-State Resistance : 1.2 Ω (MAX.)
- Isolation Voltage : 1500 V_{rms} (MIN.)

PIN CONFIGURATION (TOP VIEW)

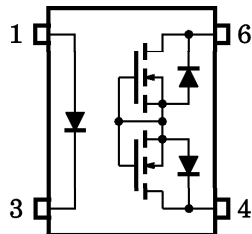

- 1 : ANODE
- 3 : CATHODE
- 4 : DRAIN
- 6 : DRAIN

Unit in mm

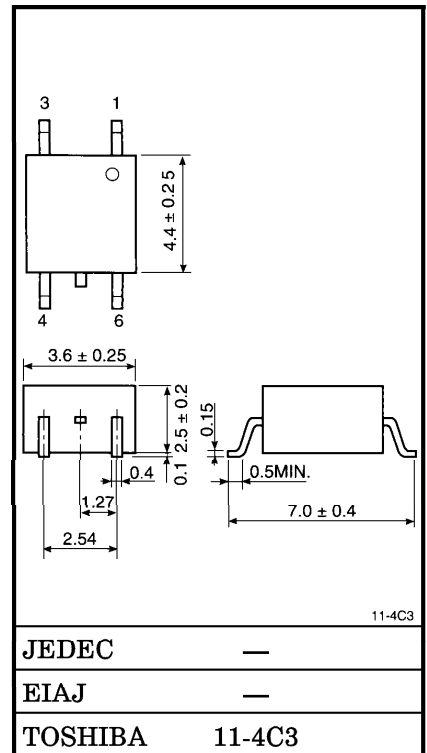

Weight : 0.1 g

MAXIMUM RATINGS (Ta = 25°C)

| CHARACTERISTIC | | SYMBOL | RATING | UNIT |
|---|--------------------------|-----------|---------|-----------|
| LED | Forward Current | I_F | 50 | mA |
| | Reverse Voltage | V_R | 6 | V |
| | Junction Temperature | T_j | 125 | °C |
| DETECTOR | Off-State Output Voltage | V_{OFF} | 60 | V |
| | On-State Current | I_{ON} | 350 | mA |
| | Junction Temperature | T_j | 125 | °C |
| Storage Temperature | | T_{stg} | -40~125 | °C |
| Operating Temperature | | T_{opr} | -20~85 | °C |
| Lead Soldering Temperature (10 s) | | T_{sol} | 260 | °C |
| Isolation Voltage (AC, 1 min., R.H. ≤ 60%) (Note 1) | | BV_S | 1500 | V_{rms} |

(Note 1) : Device considered a two-terminal device : Pins 1 and 3 shorted together, and pins 4 and 6 shorted together.

RECOMMENDED OPERATING CONDITIONS

| CHARACTERISTIC | SYMBOL | MIN. | TYP. | MAX. | UNIT |
|-----------------------|-----------|------|------|------|------|
| Supply Voltage | V_{OFF} | — | — | 48 | V |
| Forward Current | I_F | 10 | — | 30 | mA |
| On-State Current | I_{ON} | — | — | 350 | mA |
| Operating Temperature | T_{opr} | 25 | — | 50 | °C |

INDIVIDUAL ELECTRICAL CHARACTERISTICS (Ta = 25°C)

| CHARACTERISTIC | | SYMBOL | TEST CONDITION | MIN. | TYP. | MAX. | UNIT |
|----------------|-------------------|-----------|--|------|------|------|---------------|
| LED | Forward Voltage | V_F | $I_F = 20 \text{ mA}$ | 1.0 | 1.2 | 1.4 | V |
| | Reverse Voltage | I_R | $V_R = 6 \text{ V}$ | — | — | 10 | μA |
| | Capacitance | C_T | $V = 0, f = 1 \text{ MHz}$ | — | 15 | — | pF |
| DETECTOR | Off-State Current | I_{OFF} | $V_{OFF} = 30 \text{ V}, T_a = 50^\circ\text{C}$ | — | 0.4 | 1 | nA |
| | Capacitance | C_{OFF} | $V = 0, f = 1 \text{ MHz}$ | — | 100 | 150 | pF |

COUPLED ELECTRICAL CHARACTERISTICS (Ta = 25°C)

| CHARACTERISTIC | SYMBOL | TEST CONDITION | MIN. | TYP. | MAX. | UNIT |
|---------------------|----------|---|------|------|------|----------|
| Trigger LED Current | I_{FT} | $I_{ON} = 350 \text{ mA}$ | — | — | 4 | mA |
| ON-State Resistance | R_{ON} | $I_{ON} = 350 \text{ mA}, I_F = 5 \text{ mA}$ | — | 0.9 | 1.2 | Ω |

ISOLATION CHARACTERISTICS (Ta = 25°C)

| CHARACTERISTIC | SYMBOL | TEST CONDITION | MIN. | TYP. | MAX. | UNIT |
|-----------------------------|-----------------|------------------------------------|----------------------|------------------|------|------------------|
| Capacitance Input to Output | C _S | V _S = 0 V, f = 1 MHz | — | 0.8 | — | pF |
| Isolation Resistance | R _S | V _S = 500 V, R.H. ≤ 60% | 5 × 10 ¹⁰ | 10 ¹⁴ | — | Ω |
| Isolation Voltage | BV _S | AC, 1 minute | 1500 | — | — | V _{rms} |
| | | AC, 1 second (in oil) | — | 3000 | — | V _{rms} |
| | | DC, 1 minute (in oil) | — | 3000 | — | V _{dc} |

SWITCHING CHARACTERISTICS (Ta = 25°C)

| CHARACTERISTIC | SYMBOL | TEST CONDITION | MIN. | TYP. | MAX. | UNIT |
|----------------|------------------|--|------|------|------|------|
| Turn-ON Time | t _{ON} | R _L = 200 Ω (Note 2) | — | — | 1 | ms |
| Turn-OFF Time | t _{OFF} | V _{DD} = 20 V, I _F = 10 mA | — | — | 1 | |

(Note 2) : SWITCHING TIME TEST CIRCUIT

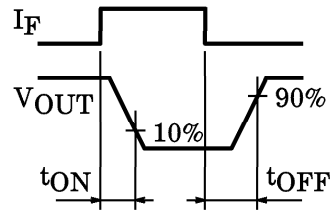
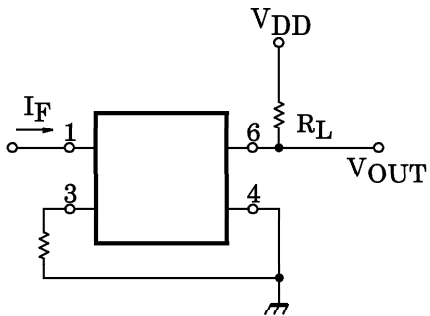

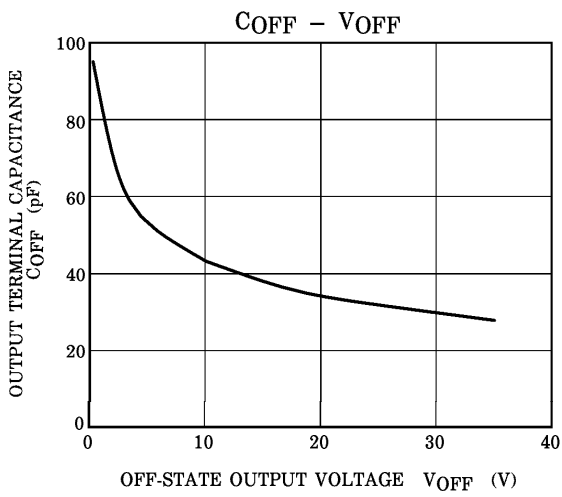
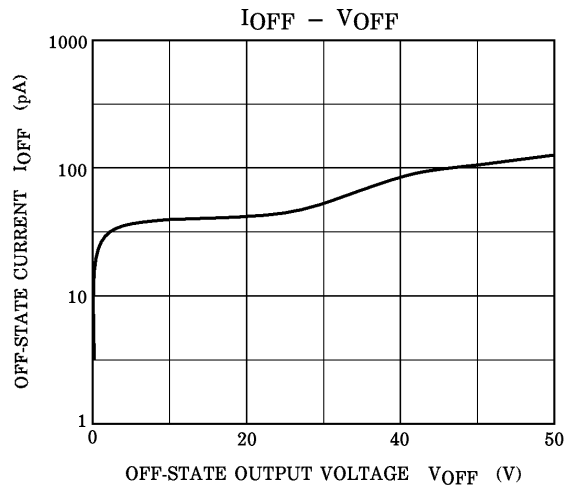
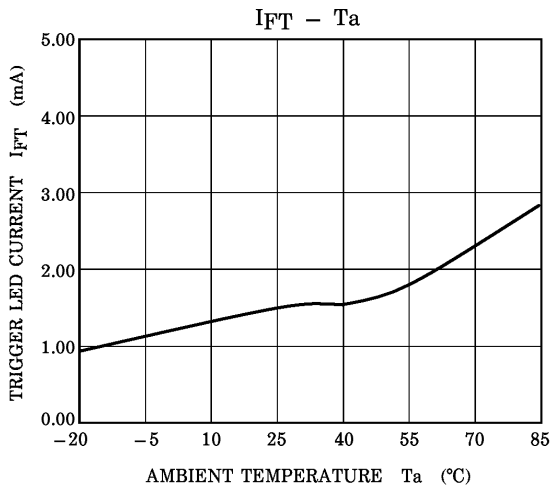

RESTRICTIONS ON PRODUCT USE

000707EBC

- TOSHIBA is continually working to improve the quality and reliability of its products. Nevertheless, semiconductor devices in general can malfunction or fail due to their inherent electrical sensitivity and vulnerability to physical stress. It is the responsibility of the buyer, when utilizing TOSHIBA products, to comply with the standards of safety in making a safe design for the entire system, and to avoid situations in which a malfunction or failure of such TOSHIBA products could cause loss of human life, bodily injury or damage to property. In developing your designs, please ensure that TOSHIBA products are used within specified operating ranges as set forth in the most recent TOSHIBA products specifications. Also, please keep in mind the precautions and conditions set forth in the "Handling Guide for Semiconductor Devices," or "TOSHIBA Semiconductor Reliability Handbook" etc..
- The TOSHIBA products listed in this document are intended for usage in general electronics applications (computer, personal equipment, office equipment, measuring equipment, industrial robotics, domestic appliances, etc.). These TOSHIBA products are neither intended nor warranted for usage in equipment that requires extraordinarily high quality and/or reliability or a malfunction or failure of which may cause loss of human life or bodily injury ("Unintended Usage"). Unintended Usage include atomic energy control instruments, airplane or spaceship instruments, transportation instruments, traffic signal instruments, combustion control instruments, medical instruments, all types of safety devices, etc.. Unintended Usage of TOSHIBA products listed in this document shall be made at the customer's own risk.
- Gallium arsenide (GaAs) is a substance used in the products described in this document. GaAs dust and fumes are toxic. Do not break, cut or pulverize the product, or use chemicals to dissolve them. When disposing of the products, follow the appropriate regulations. Do not dispose of the products with other industrial waste or with domestic garbage.
- The products described in this document are subject to the foreign exchange and foreign trade laws.
- The information contained herein is presented only as a guide for the applications of our products. No responsibility is assumed by TOSHIBA CORPORATION for any infringements of intellectual property or other rights of the third parties which may result from its use. No license is granted by implication or otherwise under any intellectual property or other rights of TOSHIBA CORPORATION or others.
- The information contained herein is subject to change without notice.

Copyright Each Manufacturing Company.

All Datasheets cannot be modified without permission.

This datasheet has been download from :

www.AllDataSheet.com

100% Free DataSheet Search Site.

Free Download.

No Register.

Fast Search System.

www.AllDataSheet.com