

2 - 20 GHz Gain Block Amplifier

TGA8622-SCC

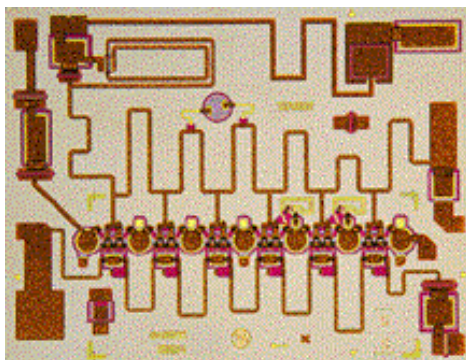

Key Features and Performance

- 2 to 20 GHz Frequency Range
- 7.5 dB Gain with Greater than 30dB Gain-Control Capability
- 20 dBm Output Power at 1 dB Gain Compression
- 7 dB Noise Figure
- Input and Output SWR 1.7:1 Midband
- 2.769 x 2.159 x 0.152 mm (0.109 x 0.085 x 0.006 in.)

Description

The TriQuint TGA8622-SCC is a broadband general-purpose amplifier that operates over the 2 to 20 GHz frequency range. Six 200um dual-gate FETs provide the amplifier with a typical gain of 7.5 dB. Midband input and output SWRs are typically 1.7:1. This amplifier is directly cascadable and can be used in both gain control and active temperature compensation applications. Ground is provided to the circuitry through vias to the backside metallization.

The TGA8622-SCC is available in chip form and is readily assembled using automated equipment. The device bond pads and backside are gold plated for compatibility with eutectic alloy attach methods as well as thermocompression and thermosonic wire-bonding processes.

**TYPICAL
SMALL-SIGNAL
POWER GAIN**
Gp vs. V_{CTRL}

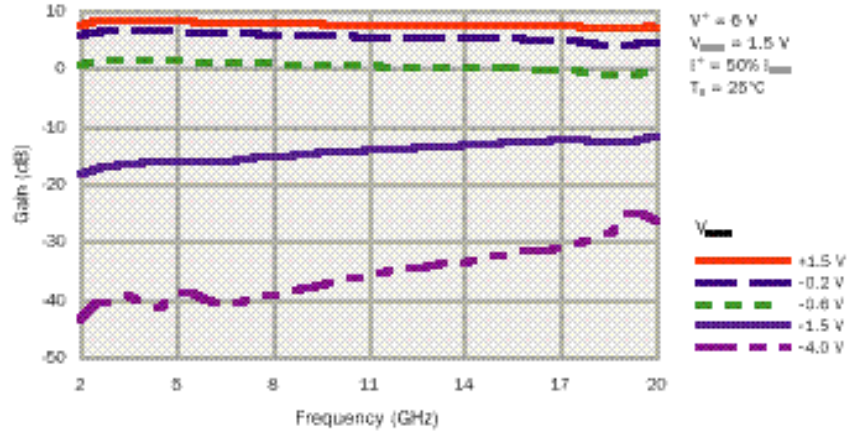

V_{CTRL} for particular gain levels is shown for reference only and may vary from device to device.

**TYPICAL
NOISE FIGURE**
NF vs. V_{CTRL}

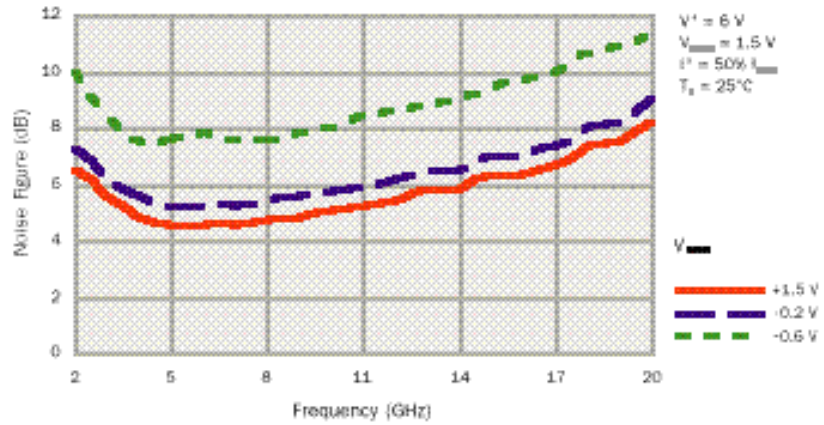

**TYPICAL
OUTPUT POWER**
P_{1dB} vs. V_{CTRL}

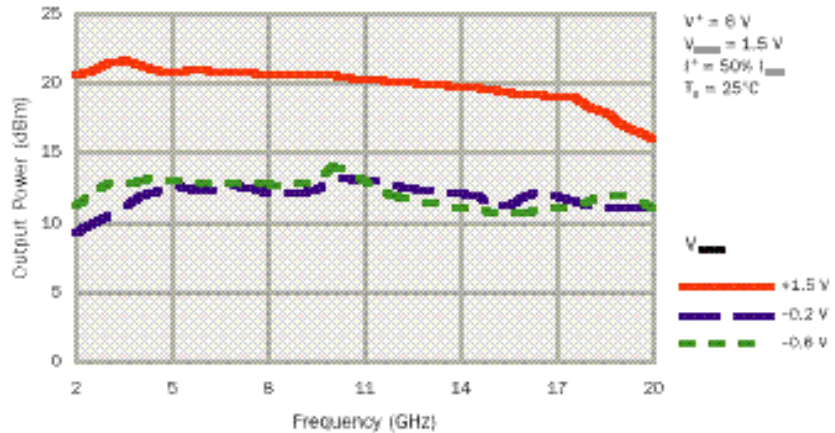

**TYPICAL
RETURN LOSS**

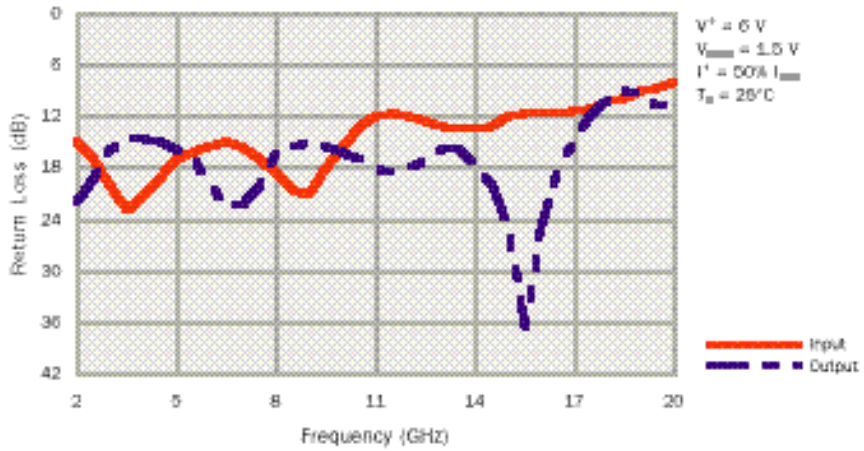

**ABSOLUTE
MAXIMUM
RATINGS**

Positive supply voltage, V^+	8 V
Positive supply voltage range with respect to negative supply voltage, $V^+ - V^-$	0 V to 12 V
Negative supply voltage range, V^-	0 V to -5 V
Gain control voltage range, V_{CTRL}	-5 V to 4 V
Gain control voltage range with respect to positive supply voltage, V_{CTRL}	0 V to -10 V
Positive supply current, I^+	370 mA
Power dissipation, P_D , at (or below) 25°C base-plate temperature *.....	2.9 W
Operating Channel temperature, T_{CH} **.....	150°C
Mounting temperature (30 sec.), T_M	320°C
Storage temperature range, T_{STG}	-65 to 150°C

Ratings over operating channel temperature range, T_{CH} (unless otherwise noted).

Stresses beyond those listed under "Absolute Maximum Ratings" may cause permanent damage to the device. These are stress ratings only, and functional operation of the device at these or any other conditions beyond those indicated under "RF Characteristics" is not implied. Exposure to absolute maximum rated conditions for extended periods may affect device reliability.

* For operation above 25°C base-plate temperature, derate linearly at the rate of 6.1 mW/°C.

** Operating channel temperature (T_{CH}) will directly affect the device MTTF. For maximum life, it is recommended that channel temperature be maintained at the lowest possible level.

TYPICAL S-PARAMETERS

Frequency (GHz)	S ₁₁		S ₂₁		S ₁₂		S ₂₂		GAIN (dB)
	MAG	ANG(°)	MAG	ANG(°)	MAG	ANG(°)	MAG	ANG(°)	
2.0	0.18	168	2.34	128	0.007	81	0.08	55	7.4
2.5	0.14	150	2.55	108	0.011	59	0.15	-33	8.1
3.0	0.10	148	2.62	87	0.013	37	0.17	-81	8.4
3.5	0.07	175	2.66	66	0.014	16	0.19	-116	8.5
4.0	0.09	-160	2.64	46	0.014	-5	0.19	-143	8.4
4.5	0.12	-153	2.61	26	0.014	-24	0.18	-165	8.3
5.0	0.14	-158	2.57	7	0.014	-37	0.17	176	8.2
5.5	0.16	-166	2.54	-12	0.015	-61	0.14	160	8.1
6.0	0.17	-177	2.49	-30	0.015	-81	0.11	152	7.9
6.5	0.18	172	2.47	-48	0.016	-99	0.07	163	7.8
7.0	0.17	163	2.46	-66	0.016	-118	0.08	-166	7.8
7.5	0.14	159	2.46	-84	0.018	-136	0.11	-149	7.8
8.0	0.12	159	2.44	-103	0.020	-155	0.15	-149	7.8
8.5	0.09	166	2.43	-121	0.021	-172	0.17	-152	7.7
9.0	0.09	-174	2.42	-139	0.023	171	0.18	-153	7.7
9.5	0.12	-161	2.41	-158	0.024	155	0.17	-157	7.7
10.0	0.17	-157	2.40	-177	0.025	139	0.16	-160	7.6
10.5	0.22	-157	2.38	165	0.026	124	0.15	-165	7.5
11.0	0.26	-160	2.36	147	0.026	108	0.13	-167	7.4
11.5	0.27	-162	2.35	128	0.026	91	0.12	-167	7.4
12.0	0.26	-165	2.35	110	0.025	77	0.13	-167	7.4
12.5	0.24	-169	2.38	91	0.025	61	0.14	-172	7.5
13.0	0.23	-174	2.36	71	0.025	44	0.17	172	7.5
13.5	0.22	-178	2.35	53	0.025	25	0.17	144	7.4
14.0	0.21	-175	2.38	33	0.025	4	0.14	120	7.5
14.5	0.22	-169	2.38	12	0.027	-18	0.10	100	7.5
15.0	0.25	-164	2.38	-8	0.028	-41	0.06	80	7.5
15.5	0.26	-162	2.39	-29	0.030	-62	0.02	2	7.6
16.0	0.26	-162	2.36	-51	0.031	-84	0.07	-122	7.5
16.5	0.26	-166	2.31	-72	0.033	-104	0.13	-151	7.3
17.0	0.26	-170	2.33	-93	0.036	-125	0.19	-175	7.3
17.5	0.28	-172	2.31	-116	0.038	-146	0.25	159	7.3
18.0	0.33	-174	2.22	-138	0.035	-166	0.31	133	6.9
18.5	0.33	-174	2.19	-159	0.037	-174	0.36	114	6.8
19.0	0.36	-169	2.21	179	0.042	163	0.37	98	6.9
19.5	0.38	-167	2.29	155	0.041	140	0.29	95	7.2
20.0	0.40	-164	2.28	125	0.040	119	0.28	133	7.1

$T_A = 25^\circ\text{C}$, $V_+ = 6\text{ V}$, $V_{\text{CTRL}} = 1.5\text{ V}$, $I_+ = 50\% I_{\text{DSS}}$

The reference planes for S-parameter data include bond wires as specified in the equivalent schematic. The S-parameters are also available on floppy disk and the world wide web.

RF CHARACTERISTICS

PARAMETER		TEST CONDITIONS	TYP	UNIT
G_p	Small-signal power gain	$f = 2$ to 20 GHz	7.5	dB
SWR (in)	Input standing wave ratio	$f = 2$ to 10 GHz $f = 10$ to 20 GHz	1.3:1 1.7:1	-
SWR (out)	Output standing wave ratio	$f = 2$ to 10 GHz $f = 10$ to 20 GHz	1.3:1 1.7:1	-
P_{1dB}	Output power at 1-dB gain compression	$f = 2$ to 18 GHz $f = 18$ to 20 GHz	20 17	dBm
NF	Noise figure	$f = 2$ to 20 GHz	7	dB
IP_3	Output third-order intercept point	$f = 2$ GHz $f = 10$ GHz $f = 18$ GHz	33 33 30	dBm

$T_A = 25^\circ\text{C}$, $V_+ = 6\text{ V}$, $V_{CTRL} = 1.5\text{ V}$, $I_+ = 50\% I_{DSS}$

DC CHARACTERISTICS

PARAMETER		TEST CONDITIONS	MIN	MAX	UNIT
I_{DSS}	Zero-gate-voltage drain current at saturation	$V_{DS} = 0.5\text{ V}$ to 3.5 V , $V_{GS} = 0\text{ V}$	156	444	mA

$T_A = 25^\circ\text{C}$

V_{DS} for I_{DSS} is the drain voltage between 0.5 V and 3.5 V at which drain current is highest at DC Autoprobe.

EQUIVALENT SCHEMATIC

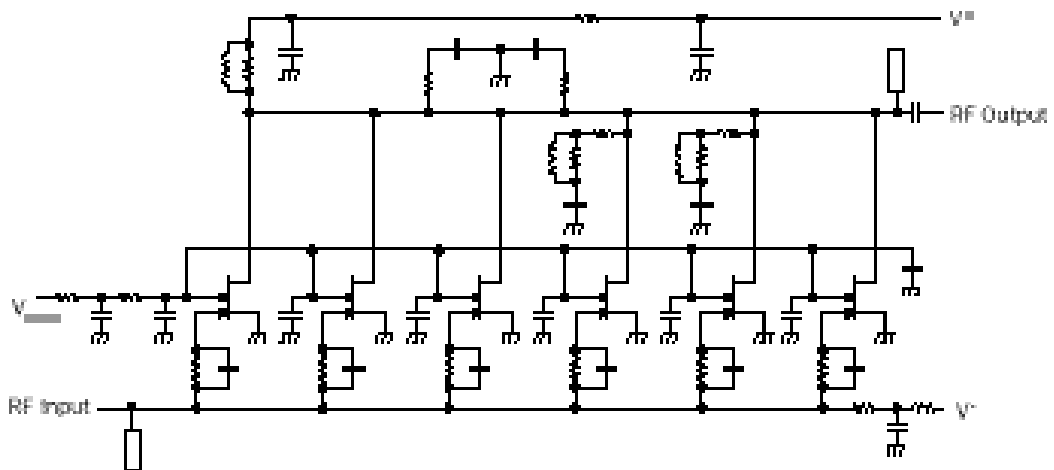

**RECOMMENDED
BIAS CIRCUIT**

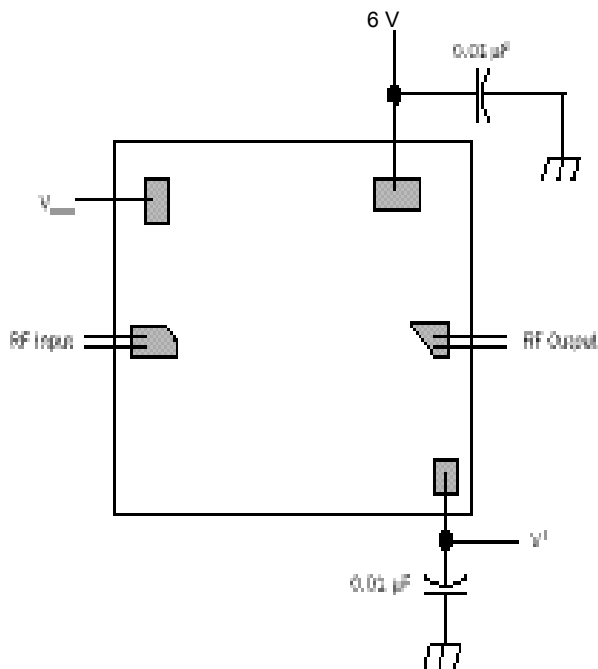

RF connections: Bond using two 1.0-mil diameter, 20-mil-length gold bond wires at both RF Input and RF Output.

Measuring I_{DSS} : Set V_- , V_+ , and V_{CTRL} to 0 V. Connect V_{CTRL} to V_+ . Short V_- to ground. Increase V_+ , V_{CTRL} from 0 V and measure I_+ maximum for V_+ , $V_{CTRL} \leq 4$ V. I_+ maximum is I_{DSS} .

Maximum gain bias (in this sequence):

Set V_- to -1 V, V_+ to 6 V, and V_{CTRL} to 1.5 V. Adjust V_- to achieve $I_+ = 50\% I_{DSS}$.

Gain reduction: Set bias for maximum gain condition and decrease V_{CTRL} from 1.5 V. (I_+ will drop accordingly; do not re-adjust V_- .)

**MECHANICAL
DRAWING**

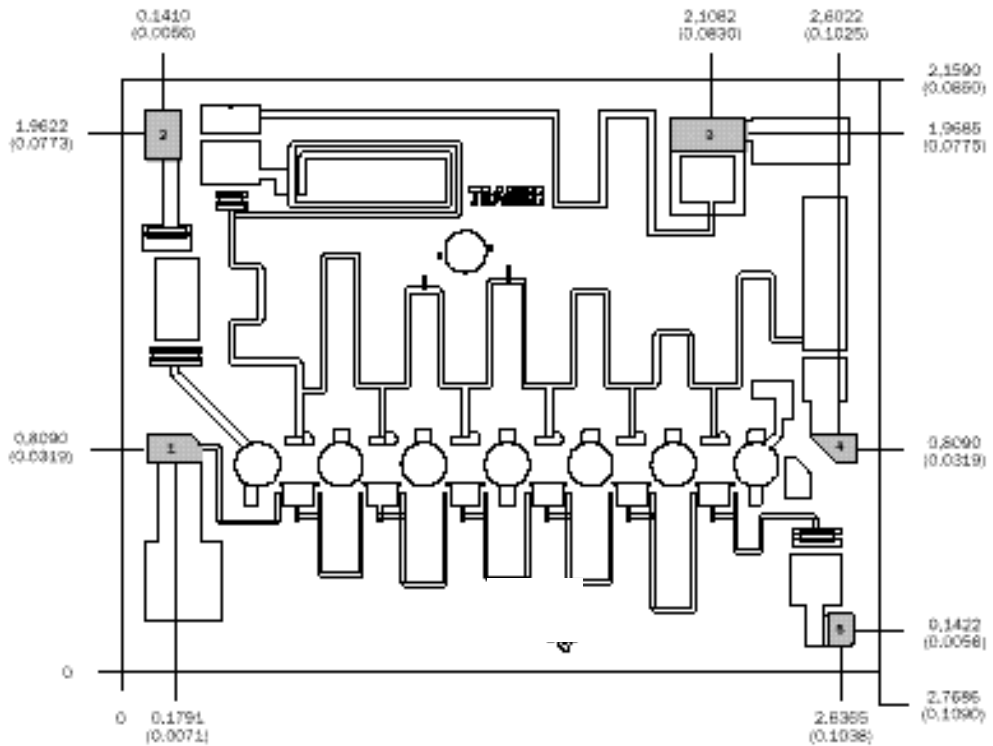

Units: millimeters (inches)

Thickness: 0,1524 (0,006) (reference only)

Chip edge to bond pad dimensions are shown to center of bond pad.

Chip size \pm 0,0508 (0,002)

Bond Pad #1 (RF Input):	0,1981 x 0,1016 (0,0078 x 0,0040)
Bond Pad #2 (V_{ctrl}):	0,1270 x 0,1778 (0,0050 x 0,0070)
Bond Pad #3 (V^+):	0,3429 x 0,1143 (0,0135 x 0,0045)
Bond Pad #4 (RF Output):	0,1676 x 0,1016 (0,0066 x 0,0040)
Bond Pad #5 (V^-):	0,0864 x 0,1245 (0,0034 x 0,0049)

GaAs MMIC devices are susceptible to damage from Electrostatic Discharge. Proper precautions should be observed during handling, assembly and test.